

THIS DRAWING CONTAINS INFORMATION PROPRIETARY TO THE DATA ON THIS DRAWING TO BE RELIABLE SINCE THE USER EMPLOY'S SUCH INFORMATION AT HIS OWN DISCRETION. RESULTS OBTAINED OR DAMAGES INCURRED FROM USE OF SUCH INFORMATION IN WHOLE OR IN PART.

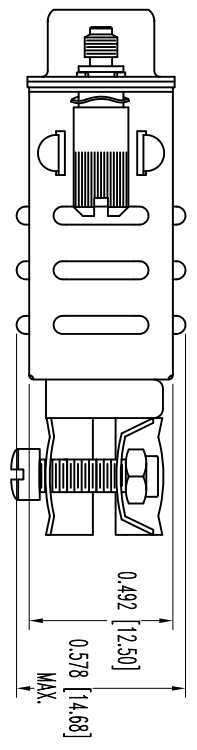
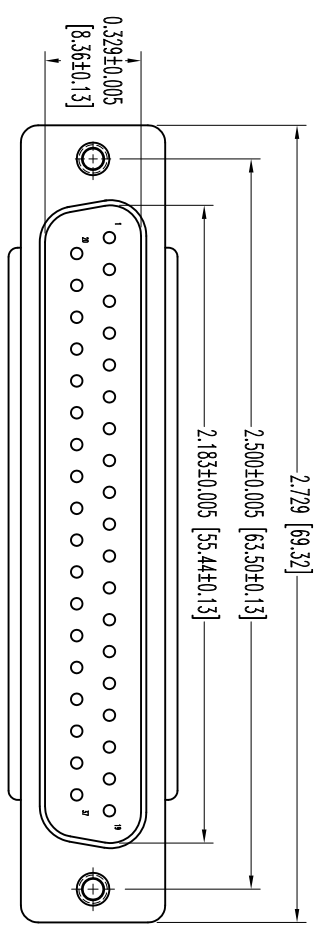
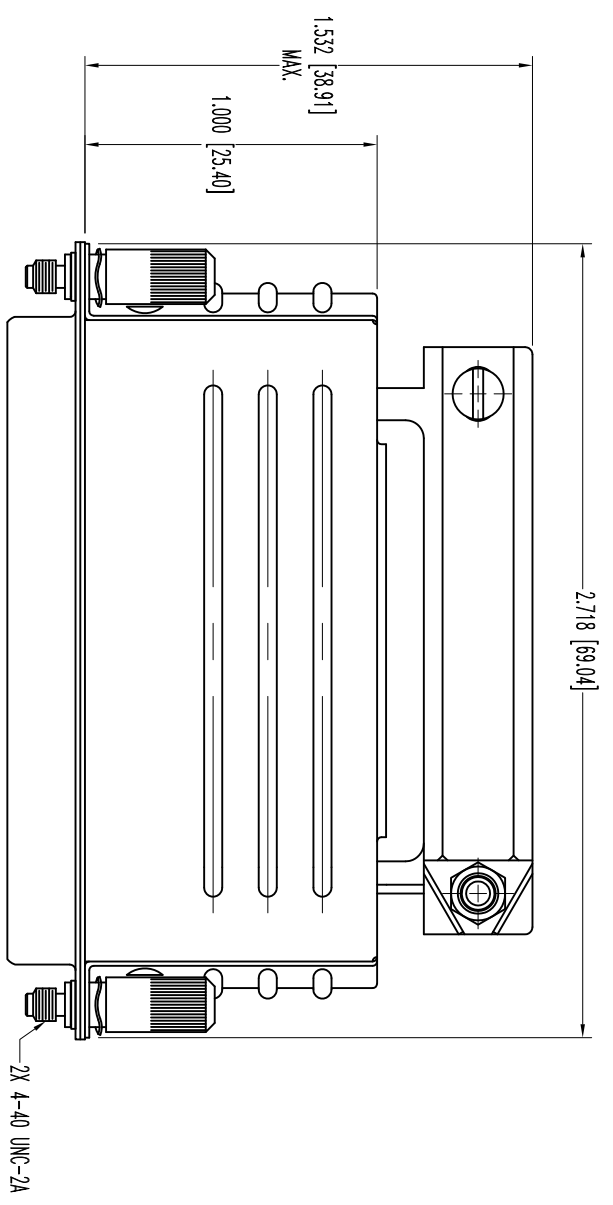

POSITRONIC INDUSTRIES INC.
www.connectpositronic.com FSC# 28198

RD SERIES
 SCALE: N.T.S.
 DRAWN BY: B SHELLADY
 APPROVED BY: COLE

DATE: 9-22-11
 DRAWING NUMBER: SK12679
 REV.: NC

DATE	REV	REVISION RECORD	APP	DR	CK
9-22	NC	ECO 34515	COLE	BS	COLE

SK12679

NOTES:

- 1. MATERIALS AND FINISHES:**
 INSULATOR: GLASS FILLED DAP PER ASTM-D5948, SDG-F, UL 94V-0, COLOR: GREEN.
 SHELLS, HOOD, AND CABLE CLAMPS: STEEL, ZINC PLATE WITH CHROMATE SEAL.
 JACKSCREWS: STEEL, ZINC PLATE WITH BLUE CHROMATE SEAL.
 WAVE WASHER AND RETAINING RING: SPRING STEEL, ZINC PLATE WITH CHROMATE SEAL.
- 2. DETAILED PRODUCT, MECHANICAL, AND ELECTRICAL INFORMATION IS AVAILABLE IN THE LATEST STANDARD DENSITY D-SUB PRODUCT PUBLICATION. VISIT CONNECTPOSITRONIC.COM/PRODUCTS/45/STANDARDENSITYD-SUBMINIATURE OR CONNECTPOSITRONIC.COM.**
- 3. DIMENSIONS ARE IN INCHES [MILLIMETERS].**