

ISDN S-INTERFACE LOW PROFILE DUAL SMT TRANSFORMERS

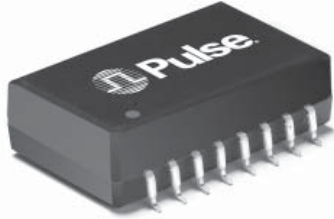

- RoHS peak reflow temperature rating 245°C
- Meets pulse waveform template of CCITT I.430 when recommended transformer and chip pair are used
- Excellent longitudinal balance
- 2 kVrms isolation voltage
- Available in Tape & Reel or tube packaging
- UL recognized

Electrical Specifications @ 25°C — Operating Temperature 0°C to 70°C

RoHS Compliant Part Number	Ratio ^A (±2%)		OCL Pri (mH MIN)	L _L Sec (μH MAX)		CW/W (pF MAX)	CD Pri ^B (pF MAX)		DCR Pri (Ω ±25%)		DCR Sec (W ±25%)		D I _{bc} ^C (mA MAX)
	A	B	A & B	A	B	A & B	A	B	A	B	A	B	
T5008NL	1:1	1:1	22	5	5	100	42	42	2.4	2.4	2.4	2.4	1

U.S. Patent No. 5,015,981Z

- A. A center-tapped** winding can be created by connecting two ends of a split center winding together on the printed circuit board. In ISDN-S applications, the primary winding is the line side transformer winding.
- B. Minimum primary** inductance and maximum distributed capacitance satisfy the transmitter output and receiver input impedance requirements of CCITT I.430 for both the TE and the NT. The maximum distributed capacitance allows sufficient margin for the capacitance of the IC and a protection diode network. It is consistent with the overall maximum value specified and the permitted length of the basic access TE cord.
- C. The maximum** specified unbalanced DC current capability is based on 20 mH minimum primary OCL. *See below for detailed packaging information.*

Mechanical

T5008NL

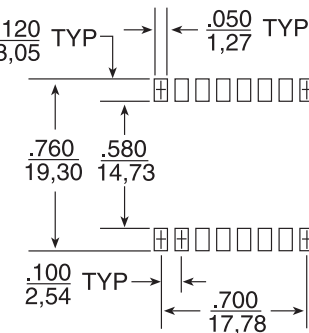
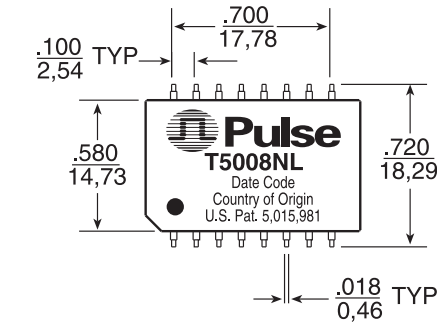

SUGGESTED PAD LAYOUT

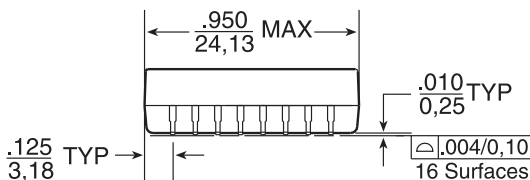

Dimensions: ^{Inches}
mm

Unless otherwise specified all tolerances are ±.010
0,25

ISDN S-INTERFACE LOW PROFILE DUAL SMT TRANSFORMERS



IC Manufacturer	IC Part Number	Dual Surface Mount
TX & RX		
Motorola	MC145474/145475 MC145574	T5008NL

***NOTE:** National recommends a 1:2 receive transformer, but used as a 1:1 ratio by connecting only half the secondary winding.

Packaging Information	
Type	SMT
Part Weight	7 grams
Parts/Tube	20
Parts/Tray*	50
Parts/Reel*	200
Reel Diameter	13 inches
Tape Width	44 mm
Pitch	24 mm

NOTE: Standard packaging for the transformer is anti-static tubes. Optional Tape & Reel packaging can be ordered by adding a "T" suffix to the end of the part number, (i.e. T5008NLT).

Application Notes

1. General Information – The S-interface is the standardized four-wire digital telephone access point defined by the CCITT I-series recommendations for the Integrated Services Digital Network. This "basic rate access" accommodates two 64 Kbps "B-channels" for information, one 16Kbps "D-channel" intended for signaling and control, and 48Kbps for framing and other purposes, giving a total rate of 192Kbps. The CCITT physical layer recommends that the user network interface be transformer coupled.

The transformer provides isolation for the line card or the terminal from the line. It is also a way to provide phantom power feeding to the terminal over the S-loop. Each end requires a transmit and a receive transformer. Chokes are used in some applications to reduce common mode noise.

Transformers described in this data sheet are matched to the transceivers offered by the IC manufacturers listed.

The use of a transformer-chip pair assures that all requirements of CCITT I.430 are met with respect to pulse waveform templates, impedance and longitudinal balance. In addition, the transformers provide the isolation voltages required by the regulatory agencies and are capable of passing surge voltage tests.

2. Safety Standards Recognition – All transformers listed in this data sheet are recognized to UL 1459 and UL 1950 as a basic insulation barrier.

3. Flammability – Materials used in the products are recognized UL94-VO. Products meet the requirements of IEC 695-2-2 (needle flame test).

4. For more application notes please refer to data sheet T604.

Common Mode Chokes

Refer to data sheet G002 for selection of low and high frequency common mode chokes.

For More Information:

Pulse Worldwide Headquarters

12220 World Trade Dr.
San Diego, CA 92128
U.S.A.

www.pulseeng.com

Tel: 858 674 8100
Fax: 858 674 8262

Pulse Europe

Einsteinstrasse 1
D-71083 Herrenberg
Germany

Tel: 49 7032 7806 0
Fax: 49 7032 7806 135

Pulse China Headquarters

B402, Shenzhen Academy of
Aerospace Technology Bldg.
10th Kejinan Rd.
High-Tech Zone
Nanshan District
Shenzen, PR China 518057

Tel: 86 755 33966678
Fax: 86 755 33966700

Pulse North China

Room 2704/2705
Super Ocean Finance Ctr.
2067 Yan An Rd. West
Shanghai 200336
China

Tel: 86 21 62787060
Fax: 86 2162786973

Pulse South Asia

135 Joo Seng Rd.
#03-02
PM Industrial Bld g.
Singapore 368363

Tel: 65 6287 8998
Fax: 65 6287 8998

Pulse North Asia

3F, No. 198
Zhongyuan Rd.
Zhongli City
Taoyuan County 320
Taiwan R. O. C.

Tel: 886 3 4356768
Fax: 886 3 4356823 (Pulse)
Fax: 886 3 4356820 (FRE)

Performance warranty of products offered on this data sheet is limited to the parameters specified. Data is subject to change without notice. Other brand and product names mentioned herein may be trademarks or registered trademarks of their respective owners.

© Copyright, 2010. Pulse Engineering, Inc. All rights reserved.