

# Isolation Power Transformers

Toroid Platform SMD

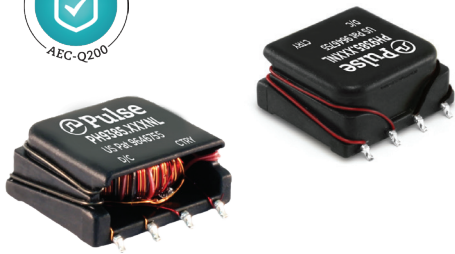

- Push Pull Converter Transformer
- IEC 60950 and 61558 basic insulation
- compliant, 12mm creepage
- 4KVRms isolation (600VRms continuous)
- Patented:** US Patent 9,646,755

## Electrical Specifications @ 25°C - Operating Temperature -40°C to +125°C

Part Number	Inductance (1-4) ( $\mu\text{H} \pm 35\%$ )	Leakage Inductance (1-4) with (5-8) shorted ( $\mu\text{H} \text{ MAX}$ )	Capacitance (1, 4) to (5, 8) (pF MAX)	DCR (1-4) ( $\Omega \text{ MAX}$ )	DCR (5-8) ( $\Omega \text{ MAX}$ )	MAX (1-4) <sup>1</sup> (V- $\mu\text{sec} \text{ Max}$ )	Turns Ratio (1:4) (8:5)	Isolated Voltage <sup>2</sup> (Vrms)
PH9385.011NL	3200	6.0	36	1.10	1.00	109	1CT : 1CT	4000
PH9385.045NL	3200	4.0	36	1.10	1.25	109	4CT : 5CT	
PH9385.034NL	2600	3.0	36	1.00	1.50	98	3CT : 4CT	
PH9385.012NL	2600	3.0	40	1.00	1.90	98	1CT : 2CT	
PH9385.038NL	2600	3.0	40	1.00	2.20	98	3CT : 8CT	
PH9385.013NL	2600	3.0	40	1.00	2.75	98	1CT : 3CT	
PH9385.027NL	2600	3.0	40	1.00	3.00	98	2CT : 7CT	
PH9385.015NL	1350	3.0	30	0.80	3.20	70	1CT : 5CT	

### Notes:

- The maximum volt-use rating limits the peak flux density to 3600 gauss when used in bi-polar drive application with 200KHz. For unipolar drive applications or a bi-polar drive with 350KHz, a maximum volt-use could be 60% of the listed value. For Push-Pull topology, where the voltage is applied across half the primary winding turns, the maximum volts-use needs to be derated by 50%.
- The AEC-Q200 temperature and humidity operational life testing was completed using a dielectric strength test of 4000Vdc.
- Optional Tape & Reel packing can be ordered by adding a "T" suffix to the part number (i.e. PH9385.011NL becomes PH9385.011NLT). Pulse complies to industry standard tape and reel specification EIA481.
- The "NL" suffix indicates an RoHS-compliant part number.
- Continuous isolation voltage confirmed by 125°C/1000hrs accelerated aging with the bias voltage applied between primary and secondary windings.

## Mechanical

## Schematic

### PH9385.0XXNL

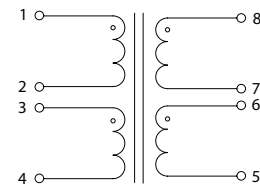
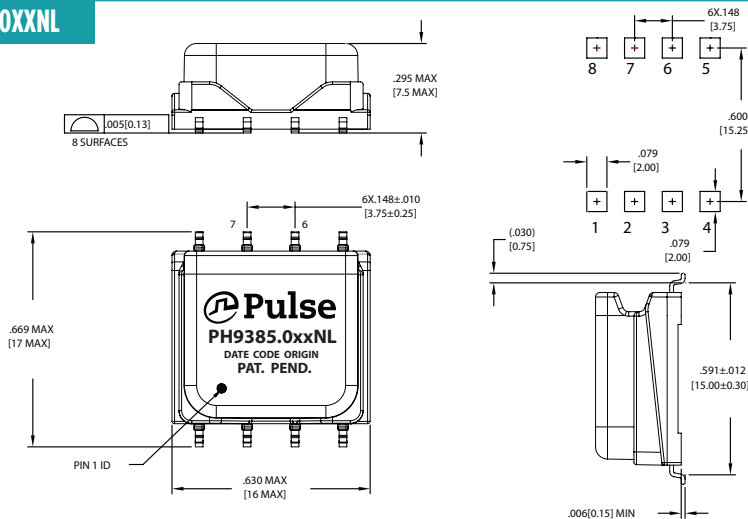

Weight .....2.5/grams  
Tape & Reel .....300/reel  
Tray .....80/tray

Dimensions:  $\frac{\text{Inches}}{\text{mm}}$

Unless otherwise specified,  
all tolerances are  $\pm \frac{.010}{0,25}$

## Application

PH9385.XXXNL is a series of high isolation power supply transformer drivers. Intended to operate in a fixed duty cycle Push Pull topology, it is a part of a low cost solution for delivering lower power (up to 2.5W) from a low voltage source. A typical implementation would be an isolated RS-485 power supply driver circuit, the design is compatible with the MAXIM™ MAX253 IC. Other IC's include Texas SN6501 UCC2808, Analog ADuM4070, ADuM447x.

A schematic diagram for the Push Pull converter topology is given below.

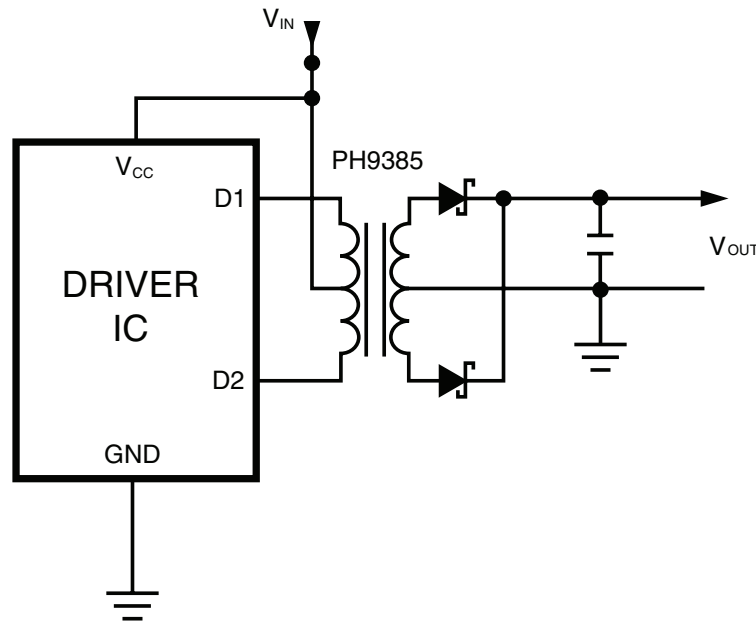

For a fixed 50% duty cycle mode of operation, the output voltage is simply determined by the input voltage and turns ratio. So, with the available turns ratios, a variety of output voltages can be selected. This range can be extended by implementing different topologies such as forward or bridge and can be used with controllers offered by different IC vendors for a number of different applications.

## For More Information

### Pulse Worldwide Headquarters

15255 Innovation Drive Ste 100  
San Diego, CA 92128  
U.S.A.

### Pulse Europe

Pulse Electronics GmbH  
Am Rottland 12  
58540 Meinerzhagen  
Germany

### Pulse China Headquarters

Pulse Electronics (ShenZhen) CO., LTD  
D708, Shenzhen Academy of  
Aerospace Technology,  
The 10th Keji South Road,  
Nanshan District, Shenzhen, P.R.  
China 518057

### Pulse North China

Room 2704/2705  
Super Ocean Finance Ctr.  
2067 Yan An Road West  
Shanghai 200336  
China

### Pulse South Asia

135 Joo Seng Road  
#03-02  
PM Industrial Bldg.  
Singapore 368363

### Pulse North Asia

3F, No. 198  
Zhongyuan Road  
Zhongli City  
Taoyuan County 32068  
Taiwan

Tel: 858 674 8100

Fax: 858 674 8262

Tel: 49 2354 777 100

Fax: 49 2354 777 168

Tel: 86 755 33966678

Fax: 86 755 33966700

Tel: 86 21 62787060

Fax: 86 2162786973

Tel: 65 6287 8998

Fax: 65 6280 0080

Tel: 886 3 4356768

Fax: 886 3 4356823

Performance warranty of products offered on this data sheet is limited to the parameters specified. Data is subject to change without notice. Other brand and product names mentioned herein may be trademarks or registered trademarks of their respective owners. © Copyright, 2017. Pulse Electronics, Inc. All rights reserved.