

# PCA9481AUK

10 A 2:1/1:2/1:1 mode switched capacitor direct charger

Rev. 1.0 — 23 August 2022

Product short data sheet

## 1 General description

---

The PCA9481AUK is a highly-integrated switched-capacitor converter with an embedded OVPFET and external FET control, targeted to provide two times the output current for fast charging applications with a 1-cell battery. The device works in 2:1 switching operation with very high efficiency (>97 %, at  $V_{VOUT} = 4\text{ V}$ ,  $I_{VOUT} = 8\text{ A}$ ), in 1:2 switching operation, or in 1:1 mode with forward and reverse direction.

As absolute maximum voltage for each VIN and VOUT, VIN input is designed to support up to 16.5 V with no pre-biased scheme and 20 V with the pre-bias enabled for USB VBUS; VOUT input is designed to support up to 7 V with the pre-bias enabled for a 1-cell battery application.

The device provides multiple safety schemes such as OV (Over-Voltage), UV (Under-Voltage), switching pin short, thermal shutdown and others.

The PCA9481AUK also has a leader/follower function built in that allows two devices to be used seamlessly in hand-held applications.

The device features all functions with I<sup>2</sup>C-bus interface, with up to 1 MHz speed.

## 2 Features and benefits

---

- Integrated 2:1 or 1:2 unregulated switched capacitor and bidirectional bypass mode with switched-capacitor converter, >97 % efficiency at 8 A output current
- 20 V tolerant DC voltage on VIN and 7 V on VOUT
- OVP FET with IVIN Regulation and Battery voltage/current loop
- Dual-phase switched-capacitor to optimize efficiency and number of components
- Minimized power dissipation schemes embedded on an internal regulator
- Multiple Safety Schemes
  - Over-temperature protection (OTP)
  - Over-voltage protection (OVP)
  - Under-voltage protection (UVP)
  - Input/output or flying capacitor short detection
  - Watchdog timers
  - Safety switching threshold detection
- 1 Mbit/s I<sup>2</sup>C-bus target interface
- Available in WLCSP70 package

## 3 Applications

---

Smart phone, tablet and other portable electronic devices with high voltage direct charging.



## 4 Ordering information

Table 1. Ordering information

Type number	Topside mark	Package		Version
		Name	Description	
PCA9481AUK	9481AUK	WLCSP70	wafer level chip scale package, 70 terminals, 0.4 mm pitch, 4.16 mm x 2.96 mm x 0.525 mm body (backside coating included)	SOT2057-1

### 4.1 Ordering options

Table 2. Ordering options

Type number	Orderable part number	Package	Packing method	Minimum order quantity	Temperature
PCA9481AUK	PCA9481AUKZ	WLCSP70	REEL 13" Q1 DP CHIPS	6000	T <sub>amb</sub> = -40 °C to +85 °C

## 5 Block diagram

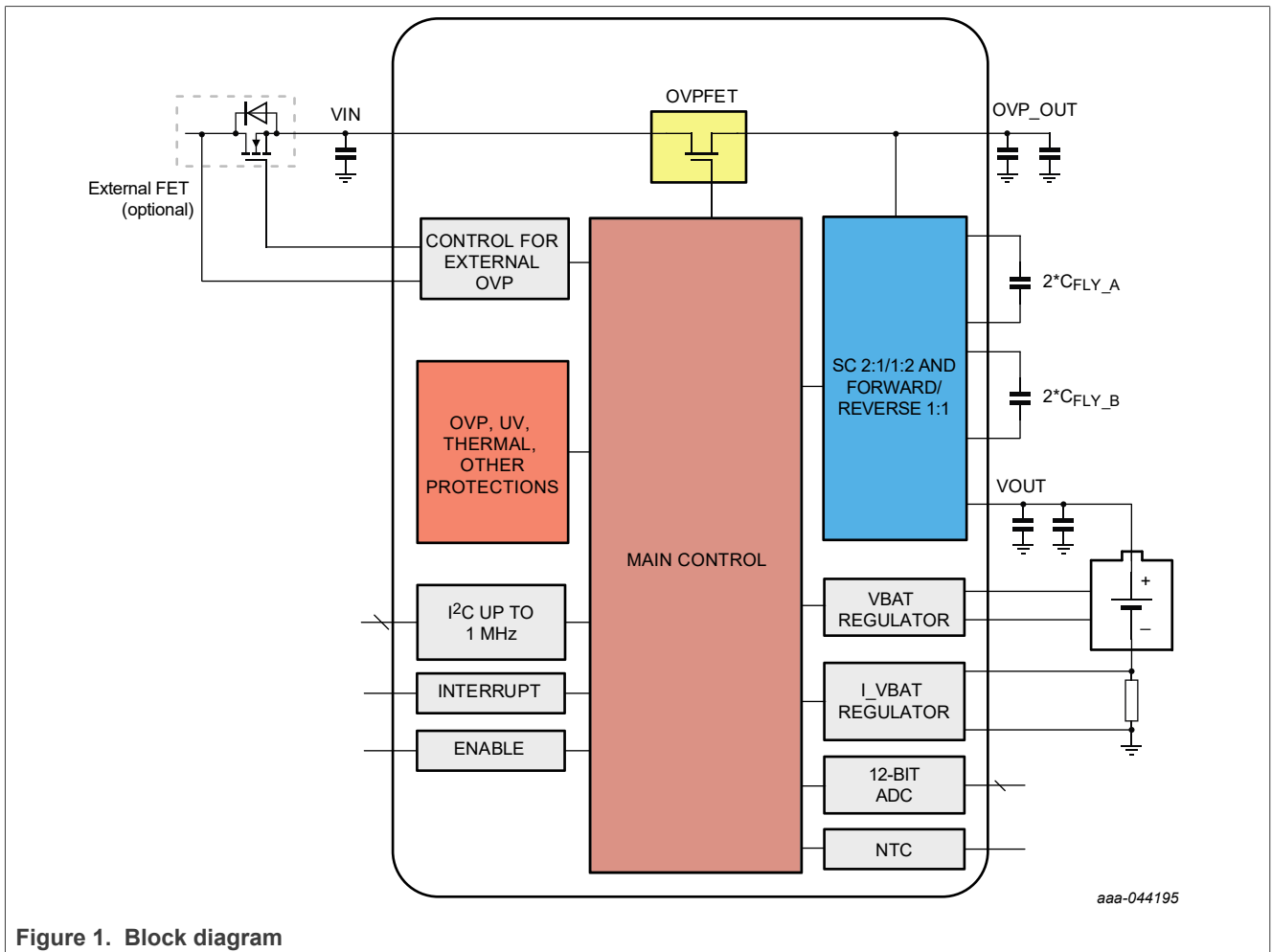

Figure 1. Block diagram

## 6 Legal information

### 6.1 Data sheet status

Document status <sup>[1][2]</sup>	Product status <sup>[3]</sup>	Definition
Objective [short] data sheet	Development	This document contains data from the objective specification for product development.
Preliminary [short] data sheet	Qualification	This document contains data from the preliminary specification.
Product [short] data sheet	Production	This document contains the product specification.

[1] Please consult the most recently issued document before initiating or completing a design.

[2] The term 'short data sheet' is explained in section "Definitions".

[3] The product status of device(s) described in this document may have changed since this document was published and may differ in case of multiple devices. The latest product status information is available on the Internet at URL <http://www.nxp.com>.

### 6.2 Definitions

**Draft** — A draft status on a document indicates that the content is still under internal review and subject to formal approval, which may result in modifications or additions. NXP Semiconductors does not give any representations or warranties as to the accuracy or completeness of information included in a draft version of a document and shall have no liability for the consequences of use of such information.

**Short data sheet** — A short data sheet is an extract from a full data sheet with the same product type number(s) and title. A short data sheet is intended for quick reference only and should not be relied upon to contain detailed and full information. For detailed and full information see the relevant full data sheet, which is available on request via the local NXP Semiconductors sales office. In case of any inconsistency or conflict with the short data sheet, the full data sheet shall prevail.

**Product specification** — The information and data provided in a Product data sheet shall define the specification of the product as agreed between NXP Semiconductors and its customer, unless NXP Semiconductors and customer have explicitly agreed otherwise in writing. In no event however, shall an agreement be valid in which the NXP Semiconductors product is deemed to offer functions and qualities beyond those described in the Product data sheet.

### 6.3 Disclaimers

**Limited warranty and liability** — Information in this document is believed to be accurate and reliable. However, NXP Semiconductors does not give any representations or warranties, expressed or implied, as to the accuracy or completeness of such information and shall have no liability for the consequences of use of such information. NXP Semiconductors takes no responsibility for the content in this document if provided by an information source outside of NXP Semiconductors.

In no event shall NXP Semiconductors be liable for any indirect, incidental, punitive, special or consequential damages (including - without limitation - lost profits, lost savings, business interruption, costs related to the removal or replacement of any products or rework charges) whether or not such damages are based on tort (including negligence), warranty, breach of contract or any other legal theory.

Notwithstanding any damages that customer might incur for any reason whatsoever, NXP Semiconductors' aggregate and cumulative liability towards customer for the products described herein shall be limited in accordance with the Terms and conditions of commercial sale of NXP Semiconductors.

**Right to make changes** — NXP Semiconductors reserves the right to make changes to information published in this document, including without limitation specifications and product descriptions, at any time and without notice. This document supersedes and replaces all information supplied prior to the publication hereof.

**Suitability for use** — NXP Semiconductors products are not designed, authorized or warranted to be suitable for use in life support, life-critical or safety-critical systems or equipment, nor in applications where failure or malfunction of an NXP Semiconductors product can reasonably be expected to result in personal injury, death or severe property or environmental damage. NXP Semiconductors and its suppliers accept no liability for inclusion and/or use of NXP Semiconductors products in such equipment or applications and therefore such inclusion and/or use is at the customer's own risk.

**Applications** — Applications that are described herein for any of these products are for illustrative purposes only. NXP Semiconductors makes no representation or warranty that such applications will be suitable for the specified use without further testing or modification.

Customers are responsible for the design and operation of their applications and products using NXP Semiconductors products, and NXP Semiconductors accepts no liability for any assistance with applications or customer product design. It is customer's sole responsibility to determine whether the NXP Semiconductors product is suitable and fit for the customer's applications and products planned, as well as for the planned application and use of customer's third party customer(s). Customers should provide appropriate design and operating safeguards to minimize the risks associated with their applications and products.

NXP Semiconductors does not accept any liability related to any default, damage, costs or problem which is based on any weakness or default in the customer's applications or products, or the application or use by customer's third party customer(s). Customer is responsible for doing all necessary testing for the customer's applications and products using NXP Semiconductors products in order to avoid a default of the applications and the products or of the application or use by customer's third party customer(s). NXP does not accept any liability in this respect.

**Limiting values** — Stress above one or more limiting values (as defined in the Absolute Maximum Ratings System of IEC 60134) will cause permanent damage to the device. Limiting values are stress ratings only and (proper) operation of the device at these or any other conditions above those given in the Recommended operating conditions section (if present) or the Characteristics sections of this document is not warranted. Constant or repeated exposure to limiting values will permanently and irreversibly affect the quality and reliability of the device.

**Terms and conditions of commercial sale** — NXP Semiconductors products are sold subject to the general terms and conditions of commercial sale, as published at <http://www.nxp.com/profile/terms>, unless otherwise agreed in a valid written individual agreement. In case an individual agreement is concluded only the terms and conditions of the respective agreement shall apply. NXP Semiconductors hereby expressly objects to applying the customer's general terms and conditions with regard to the purchase of NXP Semiconductors products by customer.

**No offer to sell or license** — Nothing in this document may be interpreted or construed as an offer to sell products that is open for acceptance or the grant, conveyance or implication of any license under any copyrights, patents or other industrial or intellectual property rights.

**Export control** — This document as well as the item(s) described herein may be subject to export control regulations. Export might require a prior authorization from competent authorities.

**Translations** — A non-English (translated) version of a document, including the legal information in that document, is for reference only. The English version shall prevail in case of any discrepancy between the translated and English versions.

**Security** — Customer understands that all NXP products may be subject to unidentified vulnerabilities or may support established security standards or specifications with known limitations. Customer is responsible for the design and operation of its applications and products throughout their lifecycles to reduce the effect of these vulnerabilities on customer's applications and products. Customer's responsibility also extends to other open and/or proprietary technologies supported by NXP products for use in customer's applications. NXP accepts no liability for any vulnerability. Customer should regularly check security updates from NXP and follow up appropriately. Customer shall select products with security features that best meet rules, regulations, and standards of the intended application and make the ultimate design decisions regarding its products and is solely responsible for compliance with all legal, regulatory, and security related requirements concerning its products, regardless of any information or support that may be provided by NXP.

NXP has a Product Security Incident Response Team (PSIRT) (reachable at [PSIRT@nxp.com](mailto:PSIRT@nxp.com)) that manages the investigation, reporting, and solution release to security vulnerabilities of NXP products.

## 6.4 Trademarks

Notice: All referenced brands, product names, service names, and trademarks are the property of their respective owners.

**NXP** — wordmark and logo are trademarks of NXP B.V.

**Tables**

Tab. 1. Ordering information .....2      Tab. 2. Ordering options .....2

**Figures**

Fig. 1. Block diagram ..... 2

---

## Contents

---

1	General description .....	1
2	Features and benefits .....	1
3	Applications .....	1
4	Ordering information .....	2
4.1	Ordering options .....	2
5	Block diagram .....	2
6	Legal information .....	3

---

Please be aware that important notices concerning this document and the product(s) described herein, have been included in section 'Legal information'.

---

© 2022 NXP B.V.

All rights reserved.

For more information, please visit: <http://www.nxp.com>

Date of release: 23 August 2022  
Document identifier: PCA9481AUK\_SDS