

PSR-SCP- 24DC/ESD/5X1/1X2/ T 1

Order No.: 2981143

<http://catalog.phoenixcontact.net/phoenix/treeViewClick.do?UID=2981143>

Safety relay for emergency stop and safety door monitoring up to SIL 3 or Cat. 4, PL e according to EN ISO 13849, automatic or manual activation, 3 N/O contacts, 1 N/C contact, 2 N/O contacts with fixed 1.0 s dropout delay, plug-in screw connection terminal blocks



Commercial data	
EAN	 4 017918 949013
sales group	G521
Pack	1 Pcs.
Customs tariff	85364900
Gross weight in pieces	0.4828 KG
Net weight per piece	0.4639 KG
Catalog page information	Page 74 (C-8-2013)

Product notes

WEEE/RoHS-compliant since:
03/21/2007

<http://www.download.phoenixcontact.com>
Please note that the data given here has been taken from the online catalog. For comprehensive information and data, please refer to the user documentation. The General Terms and Conditions of Use apply to Internet downloads.

Technical data	
Dimensions	
Width	45 mm
Height	99 mm
Depth	114.5 mm

Ambient conditions

Ambient temperature (operation)	-20 °C ... 55 °C
Ambient temperature (storage/transport)	-40 °C ... 70 °C

Input data

Nominal input voltage U_N	24 V DC
Input voltage range in reference to U_N	0.85 ... 1.1
Typical input current at U_N	150 mA DC
Voltage at input/start and feedback circuit	approx. 24 V DC
Typical response time	70 ms (manual start) 600 ms (Auto-start)
Typical release time	20 ms (undelayed contacts)
Concurrence input 1/2	Infinite
Recovery time	1 s
Max. permissible overall conductor resistance	11 Ω (Input and start circuits at U_N)
Delay time	1 s \pm 20 %

Output data

Contact type	3 enabling current paths undelayed
	2 enabling current paths delayed
	1 signaling current path undelayed
Contact material	AgSnO ₂
Minimum switching voltage	15 V AC/DC
Maximum switching voltage	250 V AC/DC
Limiting continuous current	6 A
Inrush current, minimum	25 mA
Maximum inrush current	6 A
Sq. Total current	55 A ² ($I_{TH}^2 = I_1^2 + I_2^2 + I_3^2 + I_4^2 + I_5^2$)
Interrupting rating (ohmic load) max.	144 W (24 V DC, $\tau = 0$ ms)
	288 W (48 V DC, $\tau = 0$ ms)
	110 W (110 V DC, $\tau = 0$ ms)
	88 W (220 V DC, $\tau = 0$ ms)
	1500 VA (250 V AC, $\tau = 0$ ms)

Maximum interrupting rating (inductive load)	42 W (24 V DC, $\tau = 40$ ms)
	42 W (48 V DC, $\tau = 40$ ms)
	42 W (110 V DC, $\tau = 40$ ms)
	42 W (220 V DC, $\tau = 40$ ms)
Switching capacity min.	0.4 W
Output fuse	6 A fast blow (undelayed)
	C6 (24 V AC/DC) automatic device (undelayed)
	10 A gL/gG NEOZED (delayed)

General

Relay type	Electromechanically forcibly guided, dust-proof relay.
Mechanical service life	Approx. 10^7 cycles
Mounting type	DIN rail mounting
Degree of protection	IP20
Min. degree of protection of inst. location	IP54
Mounting position	any
Category according to EN 13849-1	3 (For delayed contacts)
	4 (For non-delayed contacts)
Stop category	0 (For non-delayed contacts)
	1 (For delayed contacts)
Designation	Air and creepage distances between the power circuits
Standards/regulations	DIN EN 50178/VDE 0160
Rated surge voltage / insulation	4 kV / basic isolation, (safe isolation, reinforced insulation and 6 kV between the enabling current paths (13/14, 23/24, 33/34) and the remaining current paths and between 13/14, 23/24, 33/34 between each other.)
Rated insulation voltage	250 V
Pollution degree	2
Surge voltage category	III

Connection data

Conductor cross section solid min.	0.2 mm ²
Conductor cross section solid max.	2.5 mm ²
Conductor cross section stranded min.	0.2 mm ²
Conductor cross section stranded max.	2.5 mm ²
Conductor cross section AWG/kcmil min.	24
Conductor cross section AWG/kcmil max	12

Stripping length	7 mm
Screw thread	M3
Connection method	Screw connection

Certificates / Approvals



Certification cULus Listed, GOST, Functional Safety

Certifications applied for:

Certification Ex:

Drawings

Circuit diagram

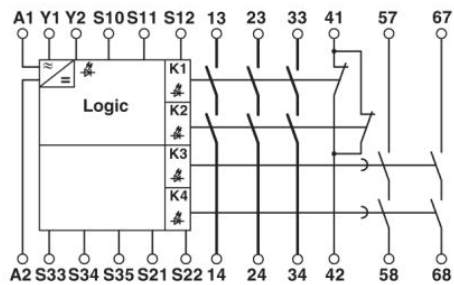

1 = logics

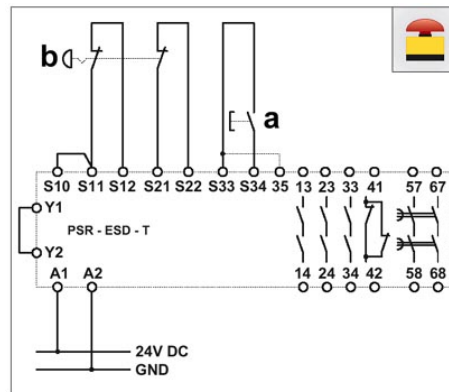

a = RESET
 b = Emergency stop
 Two-channel emergency stop circuit with cross circuiting detection and monitored reset button (bridge on S33/ S35: Automatic activation), suitable up to safety category 4.

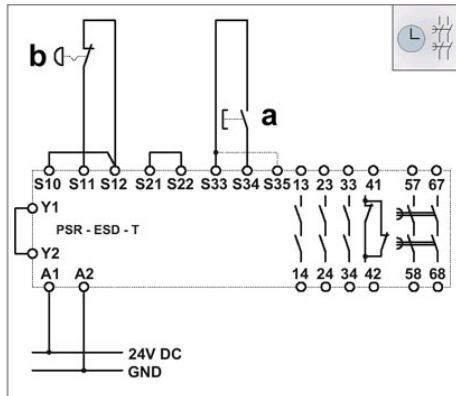

a = RESET
 b = Emergency stop
 Single-channel emergency stop circuit with monitored reset button (bridge on S33/S35: Automatic activation), suitable up to safety category 2, safety category 4 only when automatically disconnecting switches are used and cables are installed in separate plastic sheaths.

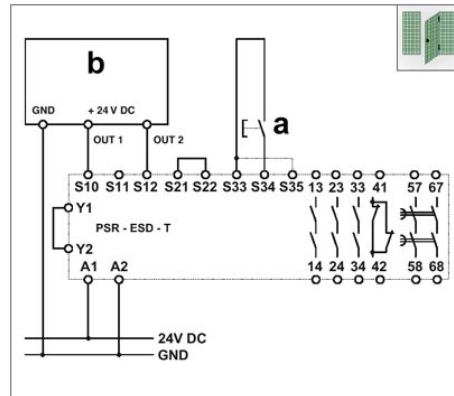

a = RESET
 b = semiconductor output
 Two-channel limit switch monitoring with semiconductor output and monitored reset button (bridge on S33/S35: Automatic activation), suitable up to safety category 4 depending on the limit switch.

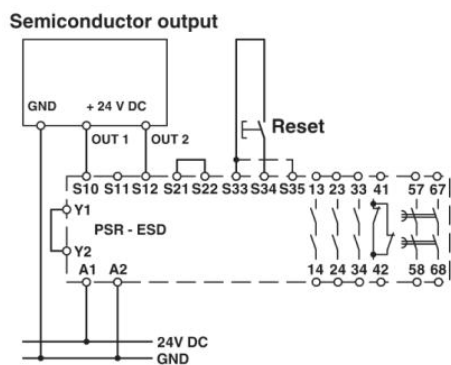
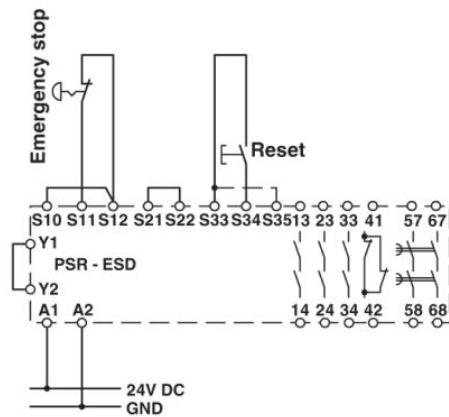
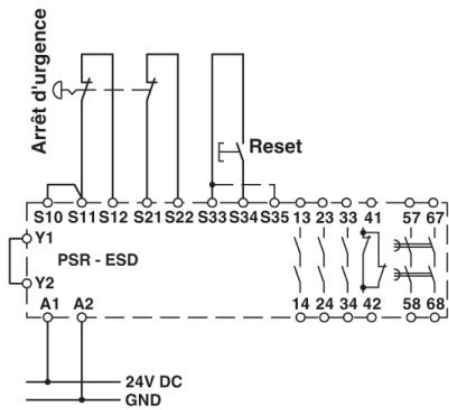

Address

PHOENIX CONTACT Deutschland GmbH
Flachmarktstr. 8
32825 Blomberg, Germany
Phone +49 5235 3 12000
Fax +49 5235 3 41200
<http://www.phoenixcontact.com>



© 2014 Phoenix Contact
Technical modifications reserved;