

Cable connector - UC-17P1N8ANNAD - 1615108

Please be informed that the data shown in this PDF Document is generated from our Online Catalog. Please find the complete data in the user's documentation. Our General Terms of Use for Downloads are valid (<http://phoenixcontact.com/download>)

Cable connector, UC, angled, shielded: yes, Screw locking, M23, No. of pos.: 17, type of contact: Pin, Crimp connection, cable diameter range: 13.5 mm ... 14.5 mm



The figure shows the 12-pos. product version



Key Commercial Data

Packing unit	8 pc
GTIN	
GTIN	4046356409254

Technical data

Environmental Product Compliance

REACH SVHC	Lead 7439-92-1
China RoHS	Environmentally Friendly Use Period = 50 years
	For details about hazardous substances go to tab "Downloads", Category "Manufacturer's declaration"

Drawings

Cable connector - UC-17P1N8ANNAD - 1615108

Schematic diagram

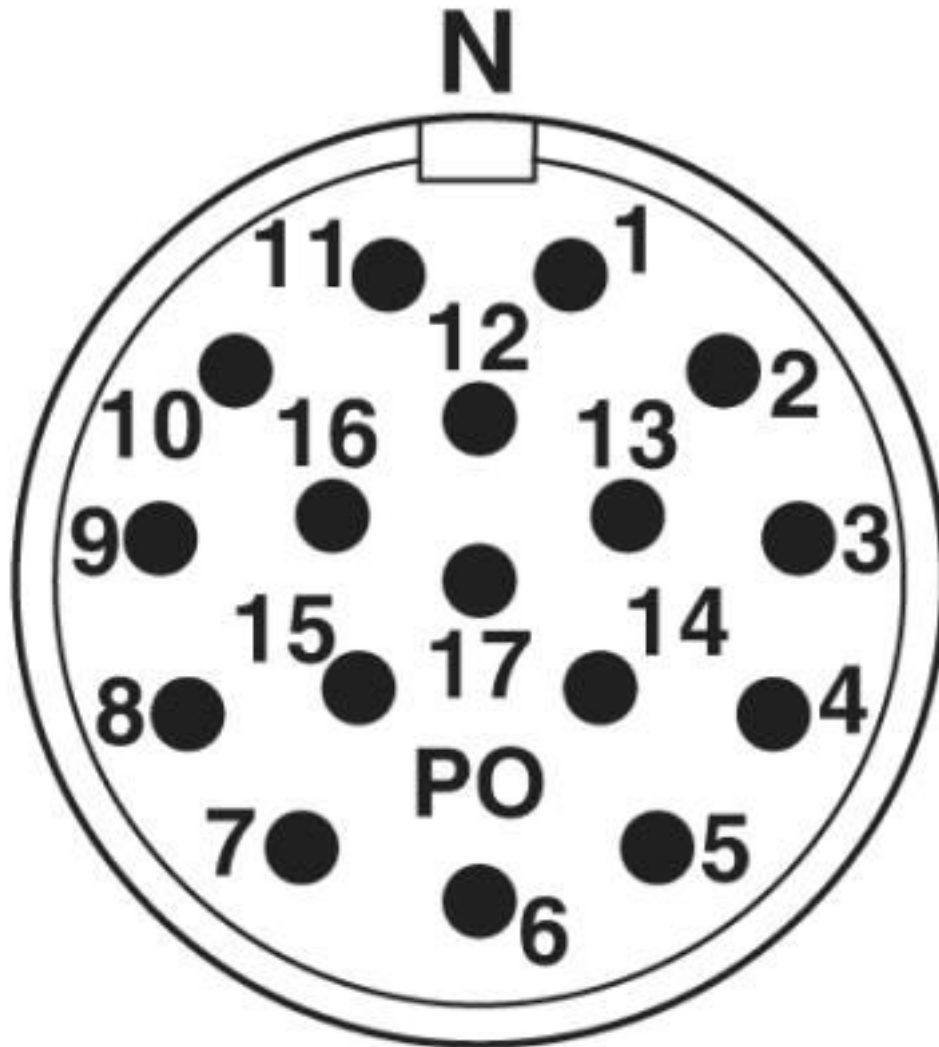

Cable connector - UC-17P1N8ANNAD - 1615108

Dimensional drawing

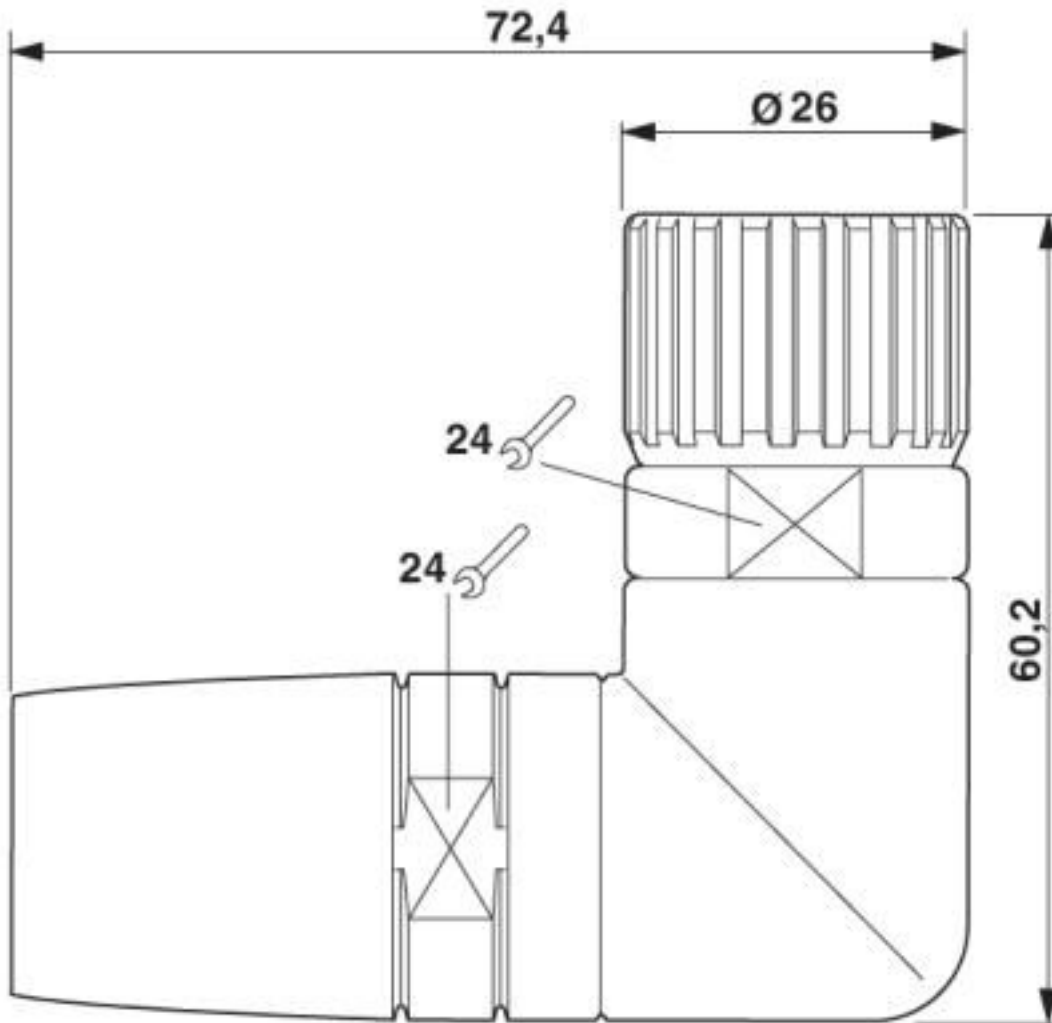

Classifications

eCl@ss

eCl@ss 10.0.1	27440102
eCl@ss 4.0	27260700
eCl@ss 4.1	27260700
eCl@ss 5.0	27260700
eCl@ss 5.1	27260700
eCl@ss 6.0	27260700
eCl@ss 7.0	27440390
eCl@ss 8.0	27440390
eCl@ss 9.0	27440102

Cable connector - UC-17P1N8ANNAD - 1615108

Classifications

ETIM

ETIM 3.0	EC001121
ETIM 4.0	EC001121
ETIM 5.0	EC001121
ETIM 6.0	EC001121
ETIM 7.0	EC001121

UNSPSC

UNSPSC 6.01	43172015
UNSPSC 7.0901	43201404
UNSPSC 11	43172015
UNSPSC 12.01	43201404
UNSPSC 13.2	39121409
UNSPSC 18.0	39121409
UNSPSC 19.0	39121409
UNSPSC 20.0	39121409
UNSPSC 21.0	39121409

Approvals

Approvals

Approvals

EAC / EAC

Ex Approvals

Approval details

EAC		B.01687
-----	---	---------

EAC		B.01687
-----	---	---------

Phoenix Contact 2020 © - all rights reserved
<http://www.phoenixcontact.com>

PHOENIX CONTACT GmbH & Co. KG
Flachmarktstr. 8
32825 Blomberg
Germany
Tel. +49 5235 300
Fax +49 5235 3 41200
<http://www.phoenixcontact.com>