

Safety relays - PSR-MS45-1NO-1DO-24DC-SC - 2904955

Please be informed that the data shown in this PDF Document is generated from our Online Catalog. Please find the complete data in the user's documentation. Our General Terms of Use for Downloads are valid (<http://phoenixcontact.com/download>)



Safety relay for emergency stop and safety doors up to SILCL 3, Cat. 4, PL e, 1 or 2-channel operation, manual, monitored start, 1 enabling current path, $U_S = 24\text{ V DC}$, fixed screw terminal block

Your advantages

- Up to Cat.4/PL e according to ISO 13849-1, SILCL 3 according to IEC 62061
- Low housing width of just 6.8 mm
- Two-channel control
- 1 enabling current path, 1 digital signal output
- Manual and monitored activation



Key Commercial Data

Packing unit	1 pc
GTIN	 4 046356 904056
GTIN	4046356904056

Technical data

Note

Utilization restriction	EMC: class A product, see manufacturer's declaration in the download area
-------------------------	---

Dimensions

Width	6.8 mm
Height	93.1 mm
Depth	102.5 mm

Ambient conditions

Ambient temperature (operation)	-40 °C ... 60 °C (observe derating)
Ambient temperature (storage/transport)	-40 °C ... 85 °C
Max. permissible relative humidity (operation)	75 % (on average, 85% infrequently, non-condensing)

Safety relays - PSR-MS45-1NO-1DO-24DC-SC - 2904955

Technical data

Ambient conditions

Max. permissible humidity (storage/transport)	75 % (on average, 85% infrequently, non-condensing)
Maximum altitude	≤ 2000 m (Above sea level)

Power supply

Rated control circuit supply voltage U_s	24 V DC -15 % / +10 %
	20.4 V DC ... 26.4 V DC
Rated control supply current I_s	typ. 42 mA
Power consumption at U_s	typ. 1 W
Inrush current	4.5 A ($\Delta t < 120 \mu s$ at U_s)
Filter time	1 ms (at A1 in the event of voltage dips at U_s)
Protective circuit	Surge protection Suppressor diode
	Protection against polarity reversal for rated control circuit supply voltage

Digital inputs

Input voltage range "0" signal	0 V DC ... 5 V DC (for safe Off; at S12)
Input current range "0" signal	0 mA ... 2 mA (for safe Off; at S12)
Inrush current	< 20 mA (with U_s/I_x to S12)
	< 10 mA (with U_s/I_x at the start circuit)
	< 5 mA (with U_s/I_x to S22/ U_s)
	> -15 mA (with U_s/I_x to S22/0V)
Current consumption	< 5 mA (with U_s/I_x to S12)
	< 5 mA (with U_s/I_x to S22/ U_s)
	< 10 mA (with U_s/I_x at the start circuit)
	> -5 mA (with U_s/I_x to S22/0V)
Filter time	max. 1.5 ms (at S12, S22; test pulse width)
	min. 7.5 ms (at S12, S22; test pulse rate)
	Test pulse rate = 5 x Test pulse width
Voltage at input/start and feedback circuit	24 V DC -15 % / +10 %
Max. permissible overall conductor resistance	150 Ω

Relay outputs: enabling current path

Output name	Enabling current path
Output description	safety-related N/O contacts
Number of outputs	1 (undelayed)
Contact type	1 enabling current path
Contact material	AgSnO ₂
Switching voltage	min. 12 V AC/DC
	max. 250 V AC/DC (Observe the load curve)
Limiting continuous current	6 A (observe derating)
Inrush current	min. 3 mA
	max. 6 A

Safety relays - PSR-MS45-1NO-1DO-24DC-SC - 2904955

Technical data

Relay outputs: enabling current path

Sq. Total current	36 A ² (observe derating)
Switching capacity	min. 60 mW
Switching frequency	max. 0.5 Hz
Mechanical service life	10x 10 ⁶ cycles
Output fuse	6 A gL/gG (N/O contact)
	4 A gL/gG (for low-demand applications)

Alarm outputs

Output description	non-safety-related
Number of outputs	1 (digital, PNP)
Voltage	22 V DC (U _s - 2 V)
Current	max. 100 mA
Maximum inrush current	500 mA (Δt = 1 ms at U _s)
Short-circuit protection	no

Times

Typical response time at US	< 175 ms
Typical release time at US	< 20 ms (when controlled via A1 or S12 and S22.)
Recovery time	< 500 ms

General

Relay type	Electromechanical relay with forcibly guided contacts in accordance with IEC/EN 61810-3 (EN 50205)
Nominal operating mode	100% operating factor
Net weight	69 g
Mounting position	vertical or horizontal
Mounting type	DIN rail mounting
Degree of protection	IP20
Min. degree of protection of inst. location	IP54
Housing material	PBT
Housing color	yellow
Operating voltage display	1 x green LED
Status display	2 x green LEDs

Connection data

Connection method	Screw connection
pluggable	no
Conductor cross section solid min.	0.2 mm ²
Conductor cross section solid max.	2.5 mm ²
Conductor cross section flexible min.	0.2 mm ²
Conductor cross section flexible max.	2.5 mm ²
Conductor cross section AWG min.	26
Conductor cross section AWG max.	12

Safety relays - PSR-MS45-1NO-1DO-24DC-SC - 2904955

Technical data

Connection data

Stripping length	12 mm
Screw thread	M3

Safety-related characteristic data

Stop category	0
Designation	IEC 61508 - High demand
Safety Integrity Level (SIL)	3
Designation	IEC 61508 - Low demand
Safety Integrity Level (SIL)	3
Designation	EN ISO 13849
Performance level (PL)	e (4 A DC13; 5 A AC15; 8760 switching cycles/year)
Category	4
Designation	EN 62061
Safety Integrity Level Claim Limit (SIL CL)	3

Standards and Regulations

Designation	Air clearances and creepage distances between the power circuits
Standards/regulations	DIN EN 50178
Rated insulation voltage	250 V AC
	250 V AC
Rated surge voltage/insulation	Safe isolation, reinforced insulation 6 kV between input circuit and enabling current path Basic insulation 4 kV between all current paths and housing
Degree of pollution	2
Overvoltage category	III
Shock	15g
Vibration (operation)	10 Hz ... 150 Hz, 2g
Conformance	CE-compliant

Environmental Product Compliance

REACH SVHC	Lead 7439-92-1
China RoHS	Environmentally Friendly Use Period = 50
	For details about hazardous substances go to tab "Downloads", Category "Manufacturer's declaration"

Drawings

Safety relays - PSR-MS45-1NO-1DO-24DC-SC - 2904955

Block diagram

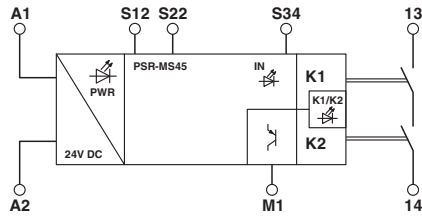

Block diagram

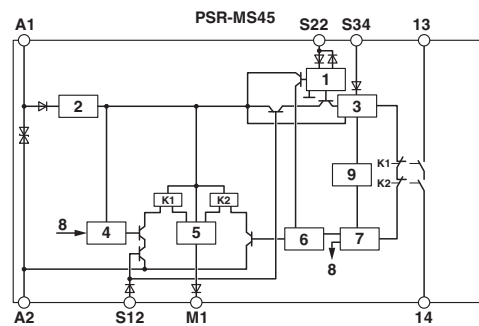

Key:

- 1 = Input circuit
- 2 = Voltage limitation
- 3 = Start circuit
- 4 = Control circuit channel 1
- 5 = Control circuit signal output
- 6 = Control circuit channel 2
- 7 = Start channel 1 and 2
- 8 = Channel 1
- 9 = Diagnostics
- K1, K2 = Force-guided elementary relays

Circuit diagram

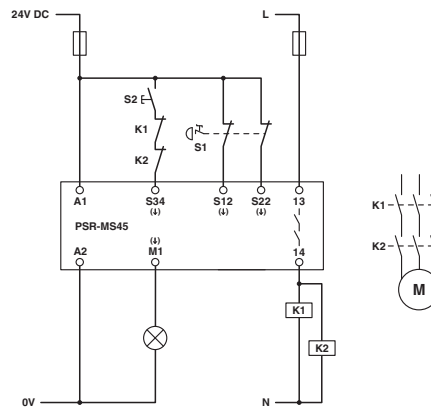

Approvals

Approvals

Approvals

UL Listed / cUL Listed / Functional Safety / UL Listed / cUL Listed / Functional Safety / EAC / EAC

Ex Approvals

Approval details

Safety relays - PSR-MS45-1NO-1DO-24DC-SC - 2904955

Approvals

UL Listed		http://database.ul.com/cgi-bin/XYV/template/LISEXT/1FRAME/index.htm	FILE E 140324
-----------	--	---	---------------

cUL Listed		http://database.ul.com/cgi-bin/XYV/template/LISEXT/1FRAME/index.htm	FILE E 140324
------------	--	---	---------------

Functional Safety			44-205-13755202
-------------------	--	--	-----------------

UL Listed		http://database.ul.com/cgi-bin/XYV/template/LISEXT/1FRAME/index.htm	FILE E 140324
-----------	--	---	---------------

cUL Listed		http://database.ul.com/cgi-bin/XYV/template/LISEXT/1FRAME/index.htm	FILE E 140324
------------	--	---	---------------

Functional Safety			44-205-13755202
-------------------	--	--	-----------------

EAC			RU C- DE.A*30.B.01082
-----	--	--	--------------------------

EAC			RU C- DE.A*30.B.01082
-----	--	--	--------------------------

Phoenix Contact 2019 © - all rights reserved
<http://www.phoenixcontact.com>

PHOENIX CONTACT GmbH & Co. KG
Flachsmarktstr. 8
32825 Blomberg
Germany
Tel. +49 5235 300
Fax +49 5235 3 41200
<http://www.phoenixcontact.com>