

Sleeve housing for cable connector - UC-0000000N3DU - 1606047

Please be informed that the data shown in this PDF Document is generated from our Online Catalog. Please find the complete data in the user's documentation. Our General Terms of Use for Downloads are valid (<http://phoenixcontact.com/download>)

Sleeve housing for cable connector, angled, Screw locking, M23, shielded: yes, cable diameter range: 10 mm ... 14 mm



Key Commercial Data

Packing unit	8 pc
GTIN	 4 046356 256957
GTIN	4046356256957
Weight per Piece (excluding packing)	182.050 g
Custom tariff number	85366990
Country of origin	Germany

Technical data

General

Note	Order information: Order contact inserts separately
Type of locking	Screw locking
Contact connection method	Crimp connection
Type of contacts	Socket
Conductor entry	10 mm ... 14 mm
Pg housing screw connection	Pg13,5

Ambient conditions

Ambient temperature	-20 °C ... 125 °C
Degree of protection	IP67

Material

Housing material	Turned parts: copper zinc alloy (CuZn), die-cast parts: zinc (GD-Zn)
Gasket and O-ring material	FPM

Specifications according to DIN EN 61984:2001

Sleeve housing for cable connector - UC-0000000N3DU - 1606047

Technical data

Specifications according to DIN EN 61984:2001

Installation height max.	2000 m
--------------------------	--------

Environmental Product Compliance

REACH SVHC	Lead 7439-92-1
China RoHS	Environmentally Friendly Use Period = 50
	For details about hazardous substances go to tab "Downloads", Category "Manufacturer's declaration"

Drawings

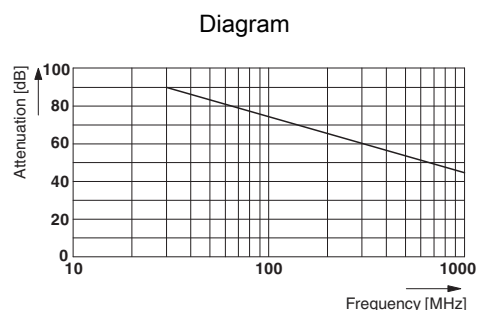
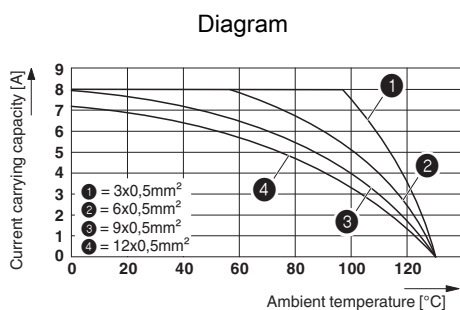

Dimensional drawing

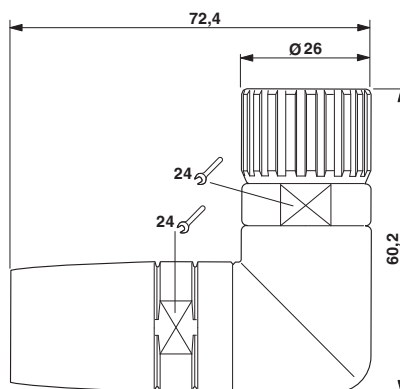

Classifications

eCl@ss

eCl@ss 4.0	272607xx
eCl@ss 4.1	27260701
eCl@ss 5.0	27260701
eCl@ss 5.1	27261200
eCl@ss 6.0	27261200
eCl@ss 7.0	27440202
eCl@ss 8.0	27440202

Sleeve housing for cable connector - UC-0000000N3DU - 1606047

Classifications

eCl@ss

eCl@ss 9.0	27440202
------------	----------

ETIM

ETIM 3.0	EC001121
ETIM 4.0	EC000437
ETIM 5.0	EC000437
ETIM 6.0	EC000437

UNSPSC

UNSPSC 6.01	43172015
UNSPSC 7.0901	43201404
UNSPSC 11	43172015
UNSPSC 12.01	43201404
UNSPSC 13.2	31261501

Approvals

Approvals

Approvals

EAC

Ex Approvals

Approval details

EAC		B.01742
-----	---	---------
