

Socket Outlet - EV-T2M3SE24-3AC20A-0,7M2,5E10 - 1405215

Please be informed that the data shown in this PDF Document is generated from our Online Catalog. Please find the complete data in the user's documentation. Our General Terms of Use for Downloads are valid (<http://phoenixcontact.com/download>)



Infrastructure Socket Outlet for charging electric vehicles with alternating current (AC), compatible with Infrastructure Plugs, Type 2, IEC 62196-2, 20 A / 480 V (AC), 24 V Locking actuator, Single wires, length: 0.7 m, Rear panel mounting, Rear protective cover screw connection

Product Description

Infrastructure Socket Outlet for charging electric vehicles (EV) with alternating current (AC), compatible with type 2 Infrastructure Plugs, for installation at charging stations for E-Mobility (EVSE)

Your advantages

- ✔ Uniform, space-saving installation space of all Phoenix Contact Infrastructure Socket Outlets
- ✔ Silver-plated surface of the power and signal contacts
- ✔ Certified in accordance with IATF 16949:2016 and ISO 9001:2015
- ✔ Manual emergency release of the locking actuator
- ✔ Integrated interlock during charging



Key Commercial Data

Packing unit	1 pc
GTIN	
GTIN	4046356738484
Weight per Piece (excluding packing)	598.000 g
Custom tariff number	85444290
Country of origin	Germany

Technical data

Product definition

Product type	Infrastructure Socket Outlet for charging electric vehicles with alternating current (AC), compatible with Infrastructure Plugs
Type	Rear protective cover screw connection
Standards/regulations	IEC 62196-2
Charging standard	Type 2
Charging mode	Mode 3, Case B

Socket Outlet - EV-T2M3SE24-3AC20A-0,7M2,5E10 - 1405215

Technical data

Product definition

Note on the connection method	Crimp connection, cannot be disconnected
-------------------------------	--

Dimensions

Height	96 mm
Width	75 mm
Depth	76.2 mm
Bore dimensions	60 mm x 60 mm
Conductor length	0.7 m (AC cables)
	0.5 m (Locking actuator cables)
Cable structure	5x 2.5 mm ² + 2x 0.5 mm ²
Type of conductor	Single wires

Ambient conditions

Ambient temperature (operation)	-30 °C ... 50 °C
Ambient temperature (storage/transport)	-40 °C ... 80 °C
Max. altitude	5000 m (above sea level)
Degree of protection	IP44 (plugged in)
	IP54 (with protective cover, see accessories)

Electrical properties

Maximum charging power	13.8 kW
Type of charging current	AC 3-phase
Number of phases	3
Number of power contacts	5 (L1, L2, L3, N, PE)
Rated current of power contacts	20 A
Rated voltage for power contacts	480 V AC
Number of signal contacts	2 (CP, PP)
Rated current for signal contacts	2 A
Rated voltage for signal contacts	30 V AC
Type of signal transmission	Pulse width modulation
Note on the connection method	Crimp connection, cannot be disconnected

Mechanical properties

Insertion/withdrawal cycles	> 10000
Insertion force	< 100 N
Withdrawal force	< 100 N

Mounting

Possible mounting positions	Rear panel mounting
	Front mounting only possible when the locking actuator is removed (see EV-T2M3SE...E00 versions)
Restrictions to mounting position	Only 0 to 90 degree frontal inclination possible, see figure
Mounting position of the locking actuator	Top center
Screw connection of a protective cover	only rear mounting possible

Socket Outlet - EV-T2M3SE24-3AC20A-0,7M2,5E10 - 1405215

Technical data

Mounting

Max. wall thickness	max. 50 mm (Rear panel mounting, normative maximum specification for infrastructure plug)
	max. 28 mm (Rear mounting, normative maximum specification for infrastructure plug when using protective cover 1405217)
	max. 10 mm (Front mounting, when using the locking mechanism)
Mounting hole diameter	7.00 mm (ø)

Design

Design line	Standard
Housing color	black
Customer variations	On request

Material

Material	Plastic
Material surface of contacts	Ag

Locking

Locking type	Locking in the inserted state with a locking mechanism
Locking voltage	24 V
Locking detection	available
Mechanical emergency release	available

Locking actuator

Typical power supply at the motor	24 V
Possible power supply range at the motor	22 V ... 26 V
Typical motor current for locking	0.05 A
Max. reverse current of the motor	0.5 A
Max. dwell time with reverse current	1000 ms
Recommended adaptation time	600 ms
Pause time after entry or exit path	3 s
Maximum voltage for locking detection	30 V
Service life	> 10000 load cycles
Ambient temperature (operation)	-30 °C ... 50 °C
Length of cable	0.5 m

Environmental Product Compliance

China RoHS	Environmentally Friendly Use Period = 10;
	For details about hazardous substances go to tab "Downloads", Category "Manufacturer's declaration"

Drawings

Socket Outlet - EV-T2M3SE24-3AC20A-0,7M2,5E10 - 1405215

Connection diagram

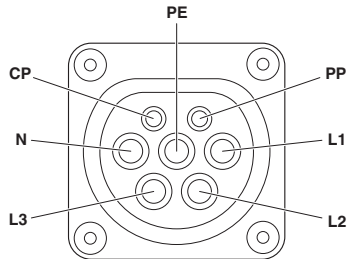

Block diagram

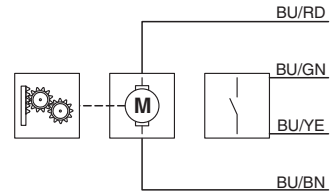

Block diagram of the locking actuator

Pin assignment of Infrastructure Socket Outlet

Diagram

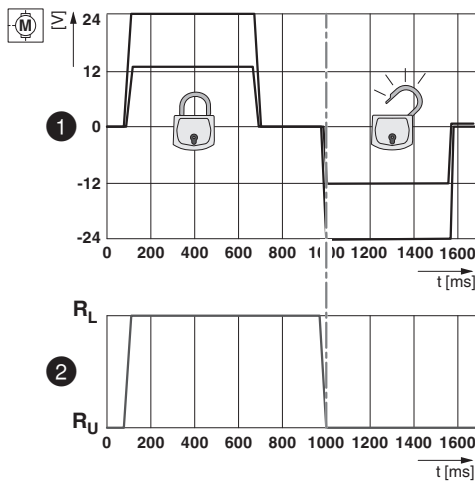

Dimensional drawing

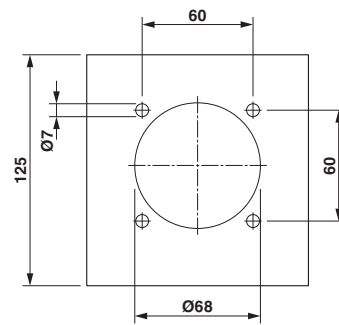

Hole image

Locking states of the locking actuator

Dimensional drawing

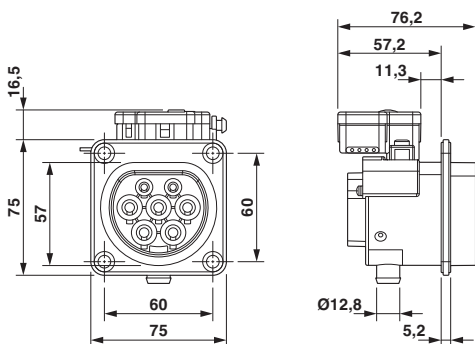

Schematic diagram

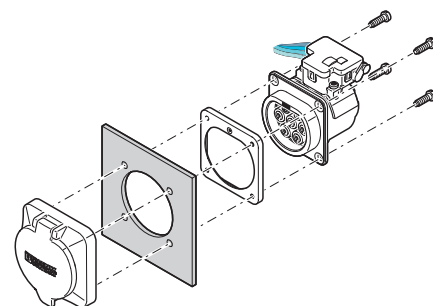

Dimensional drawing

Rear mounting with rear protective cover screw connection
 The screw connection for a protective cover from the accessories range (EV-T2SC) only supports rear mounting. The panel thickness must not exceed 5 mm. The sealing frame that is slid on from the rear must contact the housing panel flush with the flat side and must completely surround the infrastructure socket outlet.

Socket Outlet - EV-T2M3SE24-3AC20A-0,7M2,5E10 - 1405215

Schematic diagram

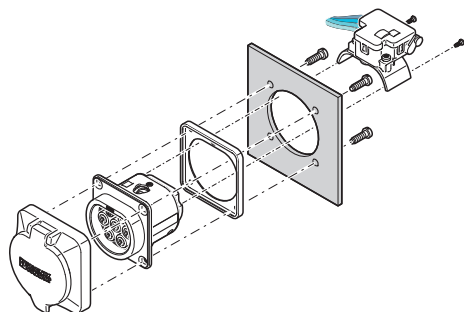

Schematic diagram

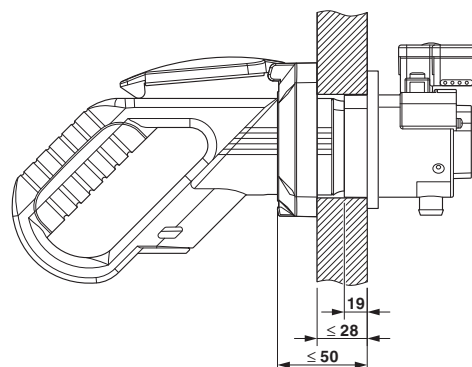

Front mounting with rear protective cover screw connection
 Front mounting is only possible when the locking actuator is removed.
 We recommend using an infrastructure socket outlet without pre-assembled locking actuator (EV-T2M3SE-...E0..., e.g., 1621729).
 The screw connection for a protective cover from the accessories range (EV-T2SC) only supports rear mounting. The panel thickness must not exceed 10 mm. The sealing frame that is slid on from the front must contact the housing panel flush with the flat side and must completely surround the infrastructure socket outlet.

Panel thickness for rear mounting (max. 50 mm, with Phoenix Contact protective cover, max. 22 mm)

Schematic diagram

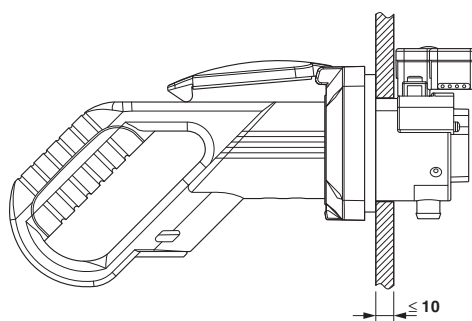

Panel thickness for front mounting (in mm)

Socket Outlet - EV-T2M3SE24-3AC20A-0,7M2,5E10 - 1405215

Schematic diagram

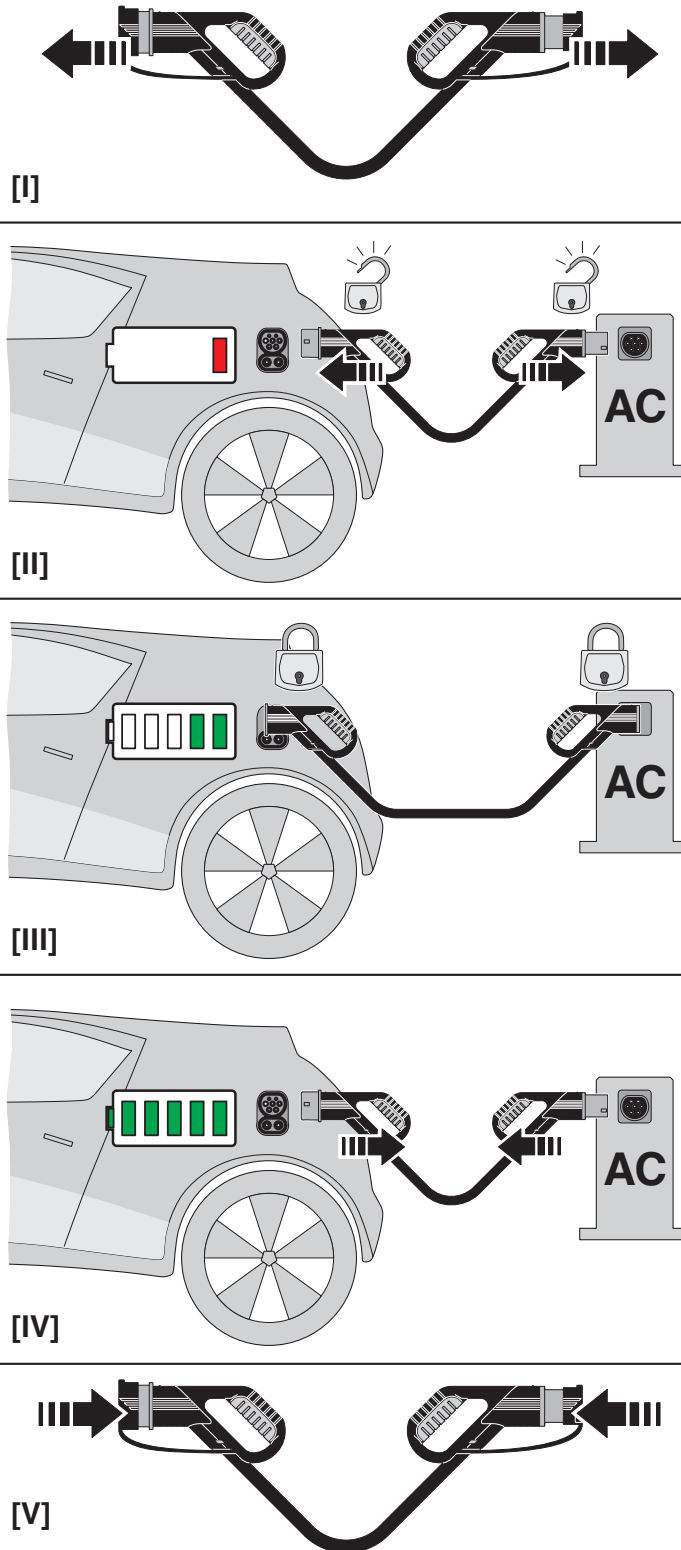

Socket Outlet - EV-T2M3SE24-3AC20A-0,7M2,5E10 - 1405215

Schematic diagram

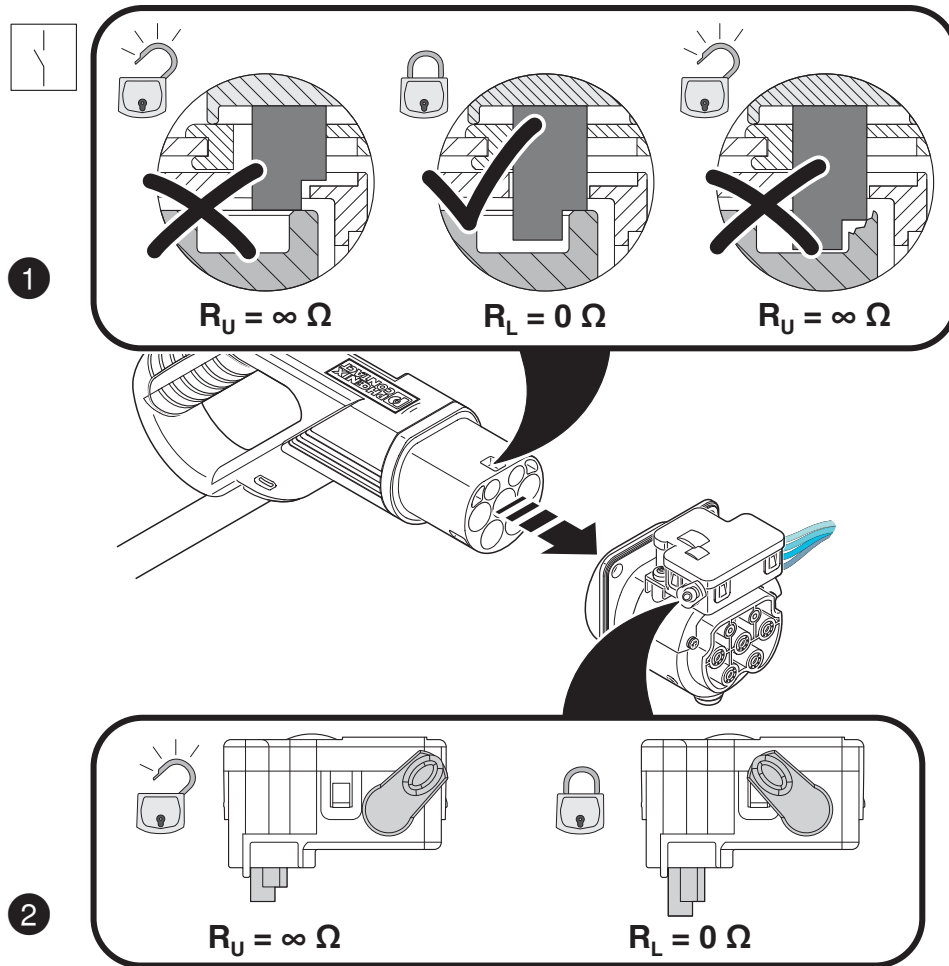

Detection of the Infrastructure Plug

Socket Outlet - EV-T2M3SE24-3AC20A-0,7M2,5E10 - 1405215

Schematic diagram

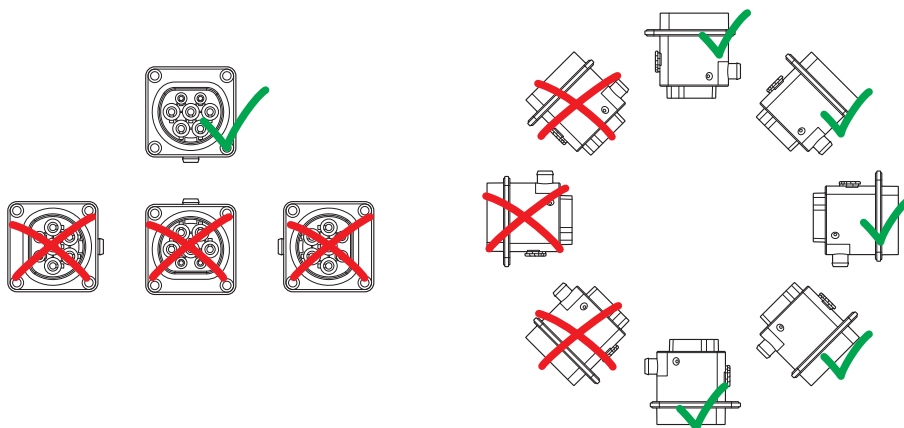

Installation positions

Classifications

eCI@ss

eCI@ss 4.0	272607xx
eCI@ss 4.1	27260701
eCI@ss 5.0	27260701
eCI@ss 5.1	27143400
eCI@ss 6.0	27143400
eCI@ss 7.0	27449001
eCI@ss 8.0	27449001
eCI@ss 9.0	27144706

ETIM

ETIM 3.0	EC002061
ETIM 4.0	EC002061
ETIM 5.0	EC001321
ETIM 6.0	EC002898

UNSPSC

UNSPSC 6.01	30211923
UNSPSC 7.0901	39121522
UNSPSC 11	39121522
UNSPSC 12.01	39121522
UNSPSC 13.2	39121522

Accessories

Accessories

AC charging controller

Socket Outlet - EV-T2M3SE24-3AC20A-0,7M2,5E10 - 1405215

Accessories

AC charging controller - EM-CP-PP-ETH - 2902802



EV charge control is used to charge electrical vehicles on the 3-phase AC mains power supply according to IEC 61851-1 Mode 3. All necessary control functions are integrated. Additional functions are available for various charging applications.

AC charging controller - EV-CC-AC1-M3-CBC-SER-HS - 1622452



The EV-CC-AC1-M3-CBC-SER-HS charging controller with housing for DIN rail mounting is used for charging electric vehicles at 3-phase AC networks according to IEC 61851-1, Mode 3. All charging functions, comprehensive configuration settings as well as a locking controller are already integrated.

AC charging controller - EV-CC-AC1-M3-CBC-SER-PCB - 1622453



The EV-CC-AC1-M3-CBC-SER-PCB charging controller as PCB is used for charging electric vehicles at 3-phase AC networks according to IEC 61851-1, Mode 3. All charging functions, comprehensive configuration settings as well as a locking controller are already integrated.

AC charging controller - EV-CC-AC1-M3-CBC-SER-PCB-XC-25 - 1627743



The EV-CC-AC1-M3-CBC-SER-PCB charging controller as PCB is used for charging electric vehicles at 3-phase AC networks according to IEC 61851-1, Mode 3. All charging functions, comprehensive configuration settings as well as a locking controller are already integrated.

AC charging controller - EV-CC-AC1-M3-CBC-SER-PCB-MSTB - 1627353



The EV-CC-AC1-M3-CBC-SER-PCB-MSTB charging controller as a PCB for charging electric vehicles according to IEC 61851-1, Mode 3, Case B (Socket Outlet) or C (Vehicle Connector). Connection via PCB connector on header.

Locking actuator

Socket Outlet - EV-T2M3SE24-3AC20A-0,7M2,5E10 - 1405215

Accessories

Locking - EV-T2M3S-E-LOCK12V - 1624129



Locking actuator with 12 V power supply for Infrastructure Socket Outlets and Vehicle Inlets, Type 2, GB/T, IEC 61851-1, 12 V Locking actuator, length: 0.5 m, Can be positioned flexibly

Locking - EV-T2M3S-E-LOCK24V - 1622317



Locking actuator with 24 V power supply for Infrastructure Socket Outlets and Vehicle Inlets, Type 2, GB/T, IEC 61851-1, 24 V Locking actuator, length: 0.5 m, Can be positioned flexibly

Panel mounting frame for Socket Outlet

Panel mounting frames - EV-T2SF - 1405218



Panel mounting frame for Infrastructure Socket Outlet, Type 2, IEC 62196-2, Front mounting, screwed on the back, Front protective cover screw connection, M5 thread

Protective cover for Socket Outlet

Protective covers - EV-T2SC - 1405217



Self-closing protective cover for infrastructure socket outlet, Type 2, IEC 62196-2, Front mounting, screwed on the front, Rear protective cover screw connection, M5 thread

Protective covers - EV-GBSCO - 1623415



Self-opening protective cover for infrastructure socket outlet, GB/T, Type 2, GB/T 20234.2, IEC 62196-2, Front mounting, on the side of the Infrastructure Socket Outlet, Rear protective cover screw connection

Socket Outlet - EV-T2M3SE24-3AC20A-0,7M2,5E10 - 1405215

Accessories

Protective covers - EV-GBSC - 1623416



Self-closing protective cover for infrastructure socket outlet, GB/T, Type 2, GB/T 20234.2, IEC 62196-2, Front mounting, on the right or left of the Infrastructure Socket Outlet, Rear protective cover screw connection

Protective covers - EV-GBSC-D6,5MM - 1623888



Self-closing protective cover for infrastructure socket outlet, GB/T, Type 2, GB/T 20234.2, IEC 62196-2, Front mounting, on the right or left of the Infrastructure Socket Outlet, Rear protective cover screw connection

Seal

Seal - EV-T2M3S-DRAINAGE-GASKET - 1621668

Seal for discharge nozzle below the Infrastructure Socket Outlet if there is no drainage tube , Type 2, IEC 62196-2

Seal - EV-T2M3S-E-LOCK-GASKET - 1621465

Seal for the mounting surface of the locking actuator above the Infrastructure Socket Outlet when there is no locking actuator present, Type 2, IEC 62196-2
