

Electronic housing - UMK-SE 11,25-1 - 2970442

Please be informed that the data shown in this PDF Document is generated from our Online Catalog. Please find the complete data in the user's documentation. Our General Terms of Use for Downloads are valid (<http://phoenixcontact.com/download>)

Side element, 11.25 mm wide, without marker groove



Why buy this product

- The modules can be marked using the marking grooves in the lateral element as well as with the Phoenix Contact PMB module marker, which is snapped into a bore hole (4 mm Ø) in the PCB
- Fast assembly thanks to the plug-in module principle. The tight engagement of the individual elements ensures that they are securely connected.
- Wide range of options for external conductor connection
- Due to the universal foot, the modules can be snapped onto standard EN DIN rails
- The mounting flange supports direct wall mounting

Key Commercial Data

| | |
|--------------------------------------|---|
| Packing unit | 1 STK |
| Minimum order quantity | 50 STK |
| GTIN |  4 017918 087722 |
| GTIN | 4017918087722 |
| Weight per Piece (excluding packing) | 5.600 g |
| Custom tariff number | 85389099 |
| Country of origin | Poland |

Technical data

General

| | |
|------------------|---------------------|
| Housing type | Panel mounting base |
| Housing material | Polyamide |
| Color | green |

Electronic housing - UMK-SE 11,25-1 - 2970442

Technical data

Technical data

| | |
|--|----|
| Flammability rating according to UL 94 | V2 |
|--|----|

Standards and Regulations

| | |
|--|----|
| Flammability rating according to UL 94 | V2 |
|--|----|

Environmental Product Compliance

| | |
|------------|---|
| China RoHS | Environmentally friendly use period: unlimited = EFUP-e |
| | No hazardous substances above threshold values |

Drawings

Dimensional drawing

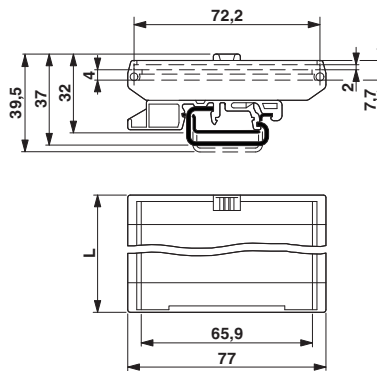

Approvals

Approvals

Approvals

UL Recognized

Ex Approvals

Approval details

| | | | |
|---------------|--|---|---------------|
| UL Recognized | | http://database.ul.com/cgi-bin/XYV/template/LISEXT/1FRAME/index.htm | FILE E 240868 |
|---------------|--|---|---------------|

