

Hybrid motor starter - ELR H3-SC- 24DC/500AC-9 - 2900530

Please be informed that the data shown in this PDF Document is generated from our Online Catalog. Please find the complete data in the user's documentation. Our General Terms of Use for Downloads are valid (<http://phoenixcontact.com/download>)



Hybrid "1 in 1" motor starter for starting 3~ AC motors with up to 550 V AC, with 24 V DC input, 9 A output current.

Product Features

- 22.5 mm wide
- Low-wear switching
- Long service life
- Space saving
- 3-phase loop bridges



Key commercial data

Packing unit	1 pc
Weight per Piece (excluding packing)	200.0 GRM
Custom tariff number	85371099
Country of origin	Germany

Technical data

Input data

Input name	Device supply
Rated control supply voltage U_s	24 V DC
Voltage range with reference to U_s	0.8 ... 1.25
Rated control supply current I_s	40 mA
Protective circuit	Protection against polarity reversal Parallel polarity protection diode
	Surge protection
Typical response time	< 35 ms
Typical turn-off time	< 40 ms
Operating voltage display	Green LED

Hybrid motor starter - ELR H3-SC- 24DC/500AC-9 - 2900530

Technical data

Input data

Status display	Yellow LED
Indication	Red LED
Input name	Control input right/left
Rated actuating voltage U_c	24 V DC
Voltage range with reference to U_c	0.8 ... 1.25
Rated actuating current I_c	5 mA
Switching threshold "0" signal, voltage	9.6 V
Switching threshold "1" signal voltage	19.2 V

Output data load output

Nominal output voltage	500 V AC
Nominal output voltage range	42 V AC ... 550 V AC
Load current	max. 9 A (see derating curve)
Min. load current	0 A
Rated operating current at AC-51	9 A
Rated operating current at AC-53a	6.5 A
Leakage current	0 mA
Residual voltage	< 0.5 V
Surge current	100 A (t = 10 ms)
Protective circuit	Surge protection

Output data reply output

Note	Confirmation 01: floating change-over contact, signal contact
Contact type	1 PDT
Contact material	AgSnO ₂ , hard gold-plated
Maximum switching voltage	30 V AC 36 V DC
Minimum switching voltage	100 mV AC/DC (at 10 mA)
Min. switching current	1 mA (at 24 V)
Maximum inrush current	50 mA
Limiting continuous current	50 mA
Interrupting rating (ohmic load) max.	1.2 W (at 24 V DC)
Note	the following values are applicable if a gold layer is destroyed
Maximum switching voltage	250 V AC/DC
Minimum switching voltage	5 V (at 100 mA)
Min. switching current	10 mA (at 12 V)
Limiting continuous current	6 A
Interrupting rating (ohmic load) max.	140 W (at 24 V DC)

Hybrid motor starter - ELR H3-SC- 24DC/500AC-9 - 2900530

Technical data

Output data reply output

	20 W (at 48 V DC)
	18 W (at 60 V DC)
	23 W (at 110 V DC)
	40 W (at 220 V DC)
	1500 VA (for 250 V AC)
Switching capacity according to IEC 60947-5-1	2 A (at 24 V, DC13)
	0.2 A (at 110 V, DC13)
	0.1 A (at 220 V, DC13)
	3 A (at 24 V, AC15)
	3 A (at 120 V, AC15)
	3 A (at 230 V, AC15)

Connection data

Connection method	Screw connection
Conductor cross section solid min.	0.14 mm ²
Conductor cross section solid max.	2.5 mm ²
Conductor cross section stranded min.	0.14 mm ²
Conductor cross section stranded max.	2.5 mm ²
Conductor cross section AWG/kcmil min.	26
Conductor cross section AWG/kcmil max	14

General

Test voltage input/output	4 kV _{rms}
Mounting position	Vertical (horizontal DIN rail)
Assembly instructions	Can be aligned with spacing = 20 mm
Operating mode	100% operating factor
Designation	Air and creepage distances between the power circuits
Standards/regulations	DIN EN 50178
Insulation	sichere Trennung
Pollution degree	2
Surge voltage category	III
Designation	Standards/regulations
Standards/regulations	EN 60947

Dimensions

Width	22.5 mm
Height	99 mm
Depth	114.5 mm

Hybrid motor starter - ELR H3-SC- 24DC/500AC-9 - 2900530

Technical data

Ambient conditions

Ambient temperature (operation)	-25 °C ... 70 °C
Ambient temperature (storage/transport)	-40 °C ... 80 °C
Degree of protection	IP20

Classifications

eCl@ss

eCl@ss 4.0	27371102
eCl@ss 4.1	27371102
eCl@ss 5.0	27371601
eCl@ss 5.1	27371601
eCl@ss 6.0	27371601
eCl@ss 7.0	27371601
eCl@ss 8.0	27371601

ETIM

ETIM 2.0	EC000066
ETIM 3.0	EC000066
ETIM 4.0	EC000066
ETIM 5.0	EC000066

UNSPSC

UNSPSC 6.01	30211915
UNSPSC 7.0901	39121514
UNSPSC 11	39121514
UNSPSC 12.01	39121514
UNSPSC 13.2	39121514

Approvals

Approvals

Approvals

UL Listed / cUL Listed / IECCE CB Scheme / UL Listed / cUL Listed / IECCE CB Scheme / cUL Listed / cULus Listed / cULus Listed / cULus Listed / null / null / null / null

Ex Approvals

Hybrid motor starter - ELR H3-SC- 24DC/500AC-9 - 2900530

Approvals

Approvals submitted

Approval details

UL Listed 

cUL Listed 

IECEE CB Scheme 

UL Listed 

cUL Listed 

IECEE CB Scheme 

cUL Listed 

cULus Listed 

Hybrid motor starter - ELR H3-SC- 24DC/500AC-9 - 2900530

Approvals

cULus Listed

cULus Listed



Accessories

Accessories

Loop bridge

Jumper - BRIDGE- 2 - 2900746



3-phase loop bridge for 2 CONTACTRON modules, with screw connection and 22.5 mm housing width, connecting cable: 0.3 m, with ferrules.

Jumper - BRIDGE- 3 - 2900747



3-phase loop bridge for 3 CONTACTRON modules, with screw connection and 22.5 mm housing width, connecting cable: 0.3 m, with ferrules.

Hybrid motor starter - ELR H3-SC- 24DC/500AC-9 - 2900530

Accessories

Jumper - BRIDGE- 4 - 2900748



3-phase loop bridge for 4 CONTACTRON modules, with screw connection and 22.5 mm housing width, connecting cable: 0.3 m, with ferrules.

Jumper - BRIDGE- 5 - 2900749



3-phase loop bridge for 5 CONTACTRON modules, with screw connection and 22.5 mm housing width, connecting cable: 0.3 m, with ferrules.

Jumper - BRIDGE- 6 - 2900750



3-phase loop bridge for 6 CONTACTRON modules, with screw connection and 22.5 mm housing width, connecting cable: 0.3 m, with ferrules.

Jumper - BRIDGE- 7 - 2900751



3-phase loop bridge for 7 CONTACTRON modules, with screw connection and 22.5 mm housing width, connecting cable: 0.3 m, with ferrules.

Jumper - BRIDGE- 8 - 2900752



3-phase loop bridge for 8 CONTACTRON modules, with screw connection and 22.5 mm housing width, connecting cable: 0.3 m, with ferrules.

Hybrid motor starter - ELR H3-SC- 24DC/500AC-9 - 2900530

Accessories

Jumper - BRIDGE- 9 - 2900753



3-phase loop bridge for 9 CONTACTRON modules, with screw connection and 22.5 mm housing width, connecting cable: 0.3 m, with ferrules.

Jumper - BRIDGE-10 - 2900754



3-phase loop bridge for 10 CONTACTRON modules, with screw connection and 22.5 mm housing width, connecting cable: 0.3 m, with ferrules.

Jumper - BRIDGE- 2-3M - 2901543



3-phase loop bridge for 2 CONTACTRON modules, with screw connection and 22.5 mm housing width, connecting cable: 3 m, with ferrules included.

Jumper - BRIDGE- 3-3M - 2901656



3-phase loop bridge for 3 CONTACTRON modules, with screw connection and 22.5 mm housing width, connecting cable: 3 m, with ferrules included.

Jumper - BRIDGE- 4-3M - 2901659



3-phase loop bridge for 4 CONTACTRON modules, with screw connection and 22.5 mm housing width, connecting cable: 3 m, with ferrules included.

Hybrid motor starter - ELR H3-SC- 24DC/500AC-9 - 2900530

Accessories

Jumper - BRIDGE- 5-3M - 2901545



3-phase loop bridge for 5 CONTACTRON modules, with screw connection and 22.5 mm housing width, connecting cable: 3 m, with ferrules included.

Jumper - BRIDGE- 6-3M - 2901697



3-phase loop bridge for 6 CONTACTRON modules, with screw connection and 22.5 mm housing width, connecting cable: 3 m, with ferrules included.

Jumper - BRIDGE- 7-3M - 2901698



3-phase loop bridge for 7 CONTACTRON modules, with screw connection and 22.5 mm housing width, connecting cable: 3 m, with ferrules included.

Jumper - BRIDGE- 8-3M - 2901700



3-phase loop bridge for 8 CONTACTRON modules, with screw connection and 22.5 mm housing width, connecting cable: 3 m, with ferrules included.

Jumper - BRIDGE- 9-3M - 2901701



3-phase loop bridge for 9 CONTACTRON modules, with screw connection and 22.5 mm housing width, connecting cable: 3 m, with ferrules included.

Hybrid motor starter - ELR H3-SC- 24DC/500AC-9 - 2900530

Accessories

Jumper - BRIDGE-10-3M - 2901702



3-phase loop bridge for 10 CONTACTRON modules, with screw connection and 22.5 mm housing width, connecting cable: 3 m, with ferrules included.

Drawings

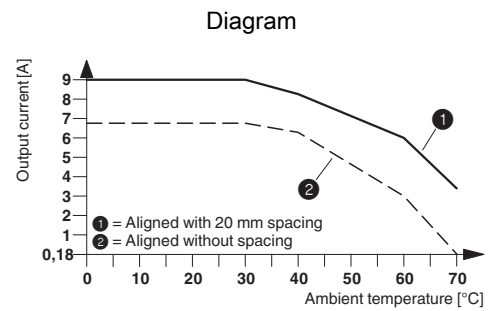
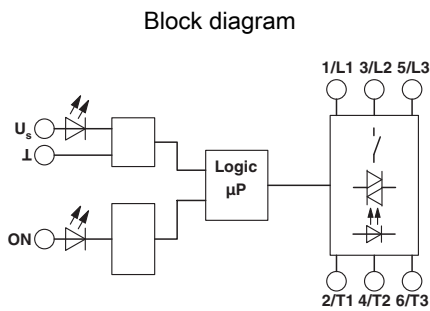

Derating curve for ELR H5-SC-24DC/500AC-9
100% operating time