

Surge protection plug - PT 2X1-24DC/FM-ST - 2920120

Please be informed that the data shown in this PDF Document is generated from our Online Catalog. Please find the complete data in the user's documentation. Our General Terms of Use for Downloads are valid (<http://phoenixcontact.com/download>)



Surge protection plug with integrated diagnostic and status indicator on the module and remote indication contact for two signal wires with common reference potential. Nominal voltage: 24 V DC

Product Features

- ✓ Plugs can be checked with CHECKMASTER
- ✓ Maximum ease of maintenance thanks to the two-piece design
- ✓ Base element remains an integral part of the installation
- ✓ With floating remote indication contact
- ✓ Consistent plug-in signal circuit protection
- ✓ Permanent and independent monitoring by a diagnostics unit
- ✓ Impedance-neutral disconnection of plug for test and maintenance purposes
- ✓ Optical status indication for the individual arresters



Key commercial data

Packing unit	1 pc
Weight per Piece (excluding packing)	30.63 GRM
Custom tariff number	85369010
Country of origin	Germany

Technical data

Dimensions

Height	45 mm
Width	17.7 mm
Depth	52 mm
Horizontal pitch	1 Div.
Complete module height	90 mm

Surge protection plug - PT 2X1-24DC/FM-ST - 2920120

Technical data

Dimensions

Complete module width	17.7 mm
Complete module depth	65.5 mm

Ambient conditions

Ambient temperature (operation)	-40 °C ... 85 °C
Degree of protection	IP20

General

Housing material	PA 6.6
Inflammability class according to UL 94	V0
Color	black
Standards for air and creepage distances	VDE 0110-1
	IEC 60664-1
Mounting type	On base element
Type	DIN rail module, two-section, divisible
Direction of action	Line-Line & Line-Signal Ground/Shield & optional Signal Ground/Shield-Earth Ground

Protective circuit

IEC test classification	C1
	C2
	C3
	D1
VDE requirement class	C1
	C2
	C3
	D1
Nominal voltage U_N	24 V DC
Maximum continuous operating voltage U_C	28 V DC
	20 V AC
Maximum continuous voltage U_C (wire-ground)	28 V DC
	20 V AC
Nominal current I_N	300 mA (45°C)
Operating effective current I_C at U_C	$\leq 5 \mu A$
Residual current I_{PE}	$\leq 1 \mu A$ (BE: 2x1+F)
	$\leq 10 \mu A$ (Directly grounded)
Nominal discharge current I_n (8/20) μs (Core-Earth)	10 kA
Total surge current (8/20) μs	20 kA
Max. discharge current I_{max} (8/20) μs maximum (Core-Earth)	10 kA

Surge protection plug - PT 2X1-24DC/FM-ST - 2920120

Technical data

Protective circuit

Nominal pulse current I_{an} (10/1000) μ s (Core-Earth)	33 A (25 °C)
Impulse discharge current (10/350) μ s, peak value I_{imp}	2.5 kA (per path)
Output voltage limitation at 1 kV/ μ s (Core-Earth) spike	≤ 50 V
	≤ 600 V (BE: 2x1+F)
Output voltage limitation at 1 kV/ μ s (Core-GND) spike	≤ 50 V
Output voltage limitation at 1 kV/ μ s (Core-Earth) static	≤ 40 V
Output voltage limitation at 1 kV/ μ s (Core-GND) static	≤ 40 V
Residual voltage at I_n , (conductor-ground)	≤ 40 V
Residual voltage with I_{an} (10/1000) μ s (conductor-ground)	≤ 50 V
Voltage protection level U_p (Core-Earth)	≤ 40 V (C1 (500 V/250 A))
	≤ 40 V (C3 - 25 A)
Voltage protection level U_p (Core-GND)	≤ 40 V (C1 (500 V/250 A))
	≤ 40 V (C3 - 25 A)
Response time t_A (Core-Earth)	≤ 1 ns
Input attenuation a_E , asym.	typ. 0.5 dB (≤ 1 MHz / 50 Ω)
	typ. 0.2 dB (≤ 400 kHz / 150 Ω)
Cut-off frequency f_g (3 dB), asym. (GND) in 50 Ohm system	typ. 6 MHz
Cut-off frequency f_g (3 dB), asym. (GND) in 150 Ohm system	typ. 2.5 MHz
Resistance in series	4.7 Ω (7-8/11-12)
Max. required back-up fuse	315 mA (e.g. T (IEC 127-2/III))
Surge current resistance (conductor-ground)	C2 - 10 kV/5 kA
	D1 - 2,5 kA
	C3 (25 A)
Alternating current carrying capacity (conductor-ground)	5 A - 1 s

Connection data

Connection method	Screw connection (in connection with the base element)
Connection type IN	PLUGTRAB plug-in system
Connection type OUT	PLUGTRAB plug-in system
Screw thread	M3
Tightening torque	0.8 Nm
Stripping length	8 mm
Conductor cross section stranded min.	0.2 mm ²
Conductor cross section stranded max.	2.5 mm ²
Conductor cross section solid min.	0.2 mm ²
Conductor cross section solid max.	4 mm ²
Conductor cross section AWG/kcmil min.	24

Surge protection plug - PT 2X1-24DC/FM-ST - 2920120

Technical data

Connection data

Conductor cross section AWG/kcmil max	12
---------------------------------------	----

Standards and Regulations

Standards/regulations	IEC 61643-21
	DIN EN 61643-21

Classifications

eCl@ss

eCl@ss 4.0	27140201
eCl@ss 4.1	27130801
eCl@ss 5.0	27130801
eCl@ss 5.1	27130801
eCl@ss 6.0	27130807
eCl@ss 7.0	27130807
eCl@ss 8.0	27130807

ETIM

ETIM 2.0	EC000943
ETIM 3.0	EC000943
ETIM 4.0	EC000943
ETIM 5.0	EC000943

UNSPSC

UNSPSC 6.01	30212010
UNSPSC 7.0901	39121610
UNSPSC 11	39121610
UNSPSC 12.01	39121610
UNSPSC 13.2	39121620

Approvals

Approvals

Approvals

UL Listed / GOST

Surge protection plug - PT 2X1-24DC/FM-ST - 2920120

Approvals

Ex Approvals

Approvals submitted

Approval details

UL Listed 

GOST 

Accessories

Accessories

Device marking

Zack marker strip - ZBN 18:UNBEDRUCKT - 2809128



Zack marker strip, Strip, white, unlabeled, can be labeled with: Plotter, Mounting type: Snap into tall marker groove, for terminal block width: 18 mm, Lettering field: 18 x 5 mm

Labeled terminal marker

Zack Marker strip, flat - ZBF 5,LGS:FORTL.ZAHLEN - 0808671



Zack Marker strip, flat, Strip, white, labeled, Printed horizontally: Consecutive numbers 1 - 10, 11 - 20, etc. up to 491 - 500, Mounting type: Snap into flat marker groove, for terminal block width: 5 mm, Lettering field: 5.15 x 5.15 mm

Surge protection plug - PT 2X1-24DC/FM-ST - 2920120

Accessories

Zack Marker strip, flat - ZBF 5,LGS:GERADE ZAHLEN - 0810821



Zack Marker strip, flat, Strip, white, labeled, Printed horizontally: Consecutive numbers 2 - 20, 22 - 40, etc. up to 82 - 100, Mounting type: Snap into flat marker groove, for terminal block width: 5 mm, Lettering field: 5.15 x 5.15 mm

Zack Marker strip, flat - ZBF 5,LGS:UNGERADE ZAHLEN - 0810863



Zack Marker strip, flat, Strip, white, labeled, Printed horizontally: Odd numbers 1 - 19, 21 - 39, etc. up to 81 - 99, Mounting type: Snap into flat marker groove, for terminal block width: 5 mm, Lettering field: 5.15 x 5.15 mm

Zack Marker strip, flat - ZBF 5,QR:FORTL.ZAHLEN - 0808697



Zack Marker strip, flat, Strip, white, labeled, Printed vertically: Consecutive numbers 1 - 10, 11 - 20, etc. up to 91 - 100, Mounting type: Snap into flat marker groove, for terminal block width: 5 mm, Lettering field: 5.15 x 5.15 mm

Marker pen

Marker pen - X-PEN 0,35 - 0811228



Marker pen without ink cartridge, for manual labeling of markers, labeling extremely wipe-proof, line thickness 0.35 mm

Terminal marking

Zack Marker strip, flat - ZBF 5:UNBEDRUCKT - 0808642



Zack Marker strip, flat, Strip, white, unlabeled, can be labeled with: Plotter, Mounting type: Snap into flat marker groove, for terminal block width: 5 mm, Lettering field: 5.1 x 5.2 mm

Surge protection plug - PT 2X1-24DC/FM-ST - 2920120

Accessories

Zack Marker strip, flat - ZBF 5/WH-100:UNBEDRUCKT - 0808668



Zack Marker strip, flat, Strip, white, unlabeled, can be labeled with: Plotter, Mounting type: Snap into flat marker groove, for terminal block width: 5 mm, Lettering field: 5.15 x 5.15 mm

Drawings

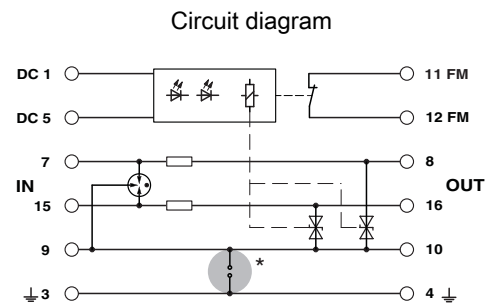
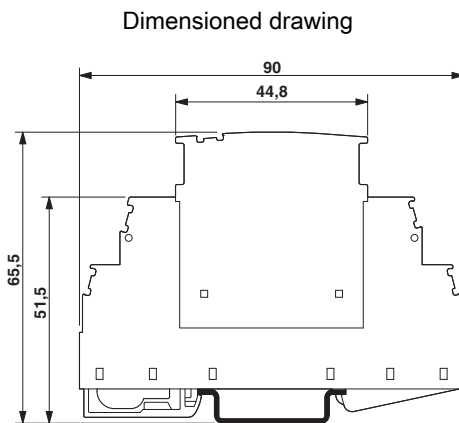

The figure shows the complete module consisting of a base element and connector

Surge protection plug - PT 2X1-24DC/FM-ST - 2920120

Catalog photo

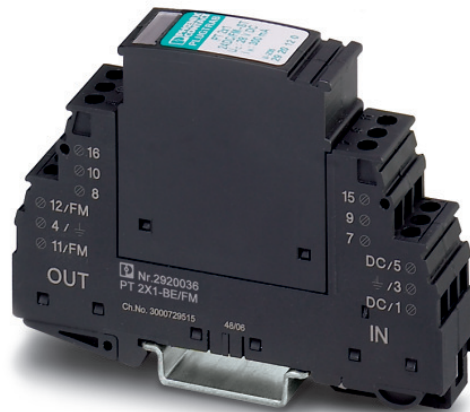

Figure may contain other products.

Phoenix Contact 2014 © - all rights reserved
<http://www.phoenixcontact.com>