

## Product change notification (PCN)

<b>Title / short description</b>	Change of the E/NS 35 N housing
<b>Affected article category</b>	Terminal blocks
<b>Change category</b>	Form and appearance, Material
<b>Change number</b>	CBE190204-00

---

### Purpose/objective of the change

Housing geometry change

### Detailed description of the change

Due to a tool renovation, the product was redesigned and changed to a different material.

### Identifying characteristics

All modified items can be identified by the incremented production batch.

<b>Start of Production (SOP)</b>	-	<b>Last Time Delivery (LTD)</b>	-
<b>Effective date (EOP)</b>	2022-01-01	<b>End of Service (EOSR)</b>	-
<b>End of Sales (EOS)</b>	-		

### Short-term change (< 6 months) or discontinuation (< 12 months), due to:

- |   |   |  |
|---|---|--|
| <input type="checkbox"/> Software / Firmware Bugfix | <input type="checkbox"/> Short-term delivery stop by supplier       | <input type="checkbox"/> Short-term recall by supplier |
| <input type="checkbox"/> Force majeure              | <input type="checkbox"/> Product improvement with customer benefits |  |
| <input type="checkbox"/> Others                     |   |  |

---

### Attachments

- CBE190204 - Designchange.pdf
- Material\_list.csv
- PCN-CBE190204-00 E/NS 35 N Gehäusenänderung\_DE
- PCN-CBE190204-00 Change of the E/NS 35 N housing\_EN

### Material list

Item	Article Type	Hardware / Firmware		Item	Substitute item Type
		old	new		
0800886	E/NS 35 N	01	02		
0800890	E/NS 35 N-VPE 1000	00	01		
0804271	E/NS 35 N BK	00	01		
0804376	E/NS 35 N BU	00	01		
3219199	E/NS 35 N/ET	01	02		
3240269	E/NS 35 N-APH	00	01		
3250218	E/NS 35 N/SEF	00	01		

## Produktänderungsmitteilung (PCN)

<b>Titel / kurze Beschreibung</b>	E/NS 35 N Gehäusenänderung
<b>Betroffene Artikelkategorie</b>	Reihenklempen
<b>Änderungskategorie</b>	Form und Erscheinung, Material
<b>Änderungsnummer</b>	CBE190204-00

---

### Zweck/Ziel der Änderung

Änderung der Gehäusegeometrie

### Detailbeschreibung der Änderung

Aufgrund einer Werkzeuerneruerung wurde das Produkt redesigned und auf anderes Material umgestellt.

### Identifizierende Merkmale

Alle geänderten Artikel sind durch die erhöhte Versionscharge zu erkennen.

<b>Beginn der Herstellung (SOP)</b>	-	<b>Letztmalige Lieferung (LTD)</b>	-
<b>Inkrafttreten der Änderung (EOP)</b>	2022-01-01	<b>Einstellung von Service (EOSR)</b>	-
<b>Einstellung des Vertriebs (EOS)</b>	-		

### Kurzfristige Änderung (< 6 Monate) oder Abkündigung (< 12 Monate), auf Grund von:

- |   |  |  |
|---|--|--|
| <input type="checkbox"/> Software / Firmware Bugfix | <input type="checkbox"/> Kurzfristiger Lieferstopp durch den Lieferanten | <input type="checkbox"/> Kurzfristiger Rückruf durch den Lieferanten |
| <input type="checkbox"/> Höhere Gewalt              | <input type="checkbox"/> Produktverbesserung mit Kundennutzen            |  |
| <input type="checkbox"/> Sonstiges                  |  |  |

---

### Anlagen

- CBE190204 - Designchange.pdf
- Material\_list.csv
- PCN-CBE190204-00 E/NS 35 N Gehäusenänderung\_DE
- PCN-CBE190204-00 Change of the E/NS 35 N housing\_EN

### Materialliste

Art.-Nr.	Artikel Typ	Revision/Versionscharge		Art.-Nr.	Ersatzartikel Typ
		alt	neu		
0800886	E/NS 35 N	01	02		
0800890	E/NS 35 N-VPE 1000	00	01		
0804271	E/NS 35 N BK	00	01		
0804376	E/NS 35 N BU	00	01		
3219199	E/NS 35 N/ET	01	02		
3240269	E/NS 35 N-APH	00	01		
3250218	E/NS 35 N/SEF	00	01		

Item	Type	old	new	Substitute item	Replacement product designation	eCl@ss 9.0
0800886	E/NS 35 N	01	02			27141135
0800890	E/NS 35 N-VPE 1000	00	01			27141135
0804271	E/NS 35 N BK	00	01			27141135
0804376	E/NS 35 N BU	00	01			27141135
3219199	E/NS 35 N/ET	01	02			27141135
3240269	E/NS 35 N-APH	00	01			27141190
3250218	E/NS 35 N/SEF	00	01			27141135

CBE190204

## E/NS 35 N - Designchange

OLD

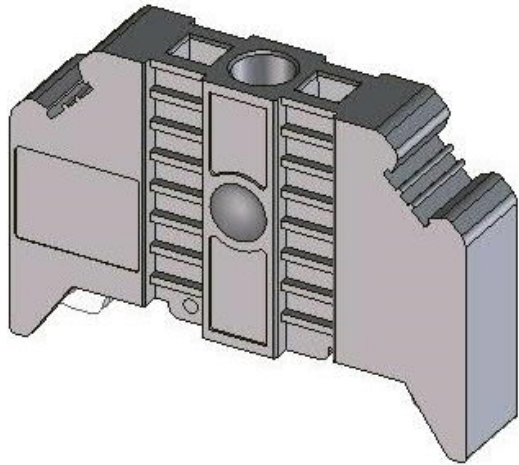

NEW

