

PRODUCT CHANGE NOTIFICATION

#PCN-MI-JF4I-15

Business Unit	Product Line Code	Type of Change	Action	Date of issue
MI	BG4	Aesthetic	Notify PxC Only	12/15/2015

The following Phoenix Contact products have been modified. Existing specifications will be met or exceeded. Please review and acknowledge this document and inform your personnel as needed.

Description of Change:

Due to a new injection mold, the geometry has been modified: change of the foot/base geometry and thinnings.
 Functionally there is no difference.

Warranty Information:

Stock Status

Can existing stock still be used? Y

Is mixture of stock acceptable? N

Transaction Dates:

Date modification goes into effect from Germany: 7/28/2015

Expected first shipment (from Phoenix Contact) of the modified product(s): 7/28/2015

Previous Product

New Product

PRODUCT CHANGE NOTIFICATION

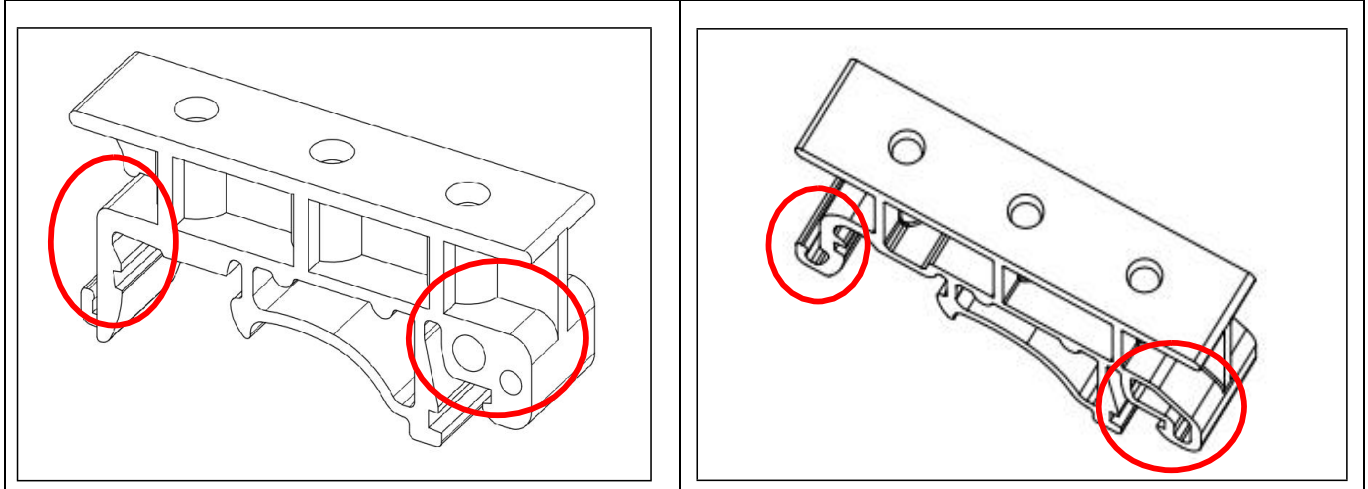

Should you have any issues with the timeline or content of this change, please contact Phoenix Contact using the contact information below. Customers should acknowledge receipt of the PCN within 30 days of delivery of the PCN; provided, however that the failure to acknowledge receipt does not affect the product change or the effective date thereof.

Contact Info:

Larry Freeland
Senior Product Marketing Manager
(800)888-7388x3209
lfreeland@phoenixcon.com

Thank you,



Larry Freeland, Senior Product Marketing Manager

Part#	Type Description
1200993	USA 10 BK
1201578	USA 10