

**PACKARD ELECTRIC DIVISION**  
 GENERAL MOTORS CORPORATION  
 WARREN, OHIO

**DO NOT SCALE**

THIS DRAWING AND DESIGN HEREON CONSTITUTES A PROPRIETARY DESIGN OF PACKARD ELECTRIC DIVISION AND IS NOT TO BE DUPLICATED OR REPRODUCED WITHOUT AUTHORITY OF PACKARD ELECTRIC DIVISION

D

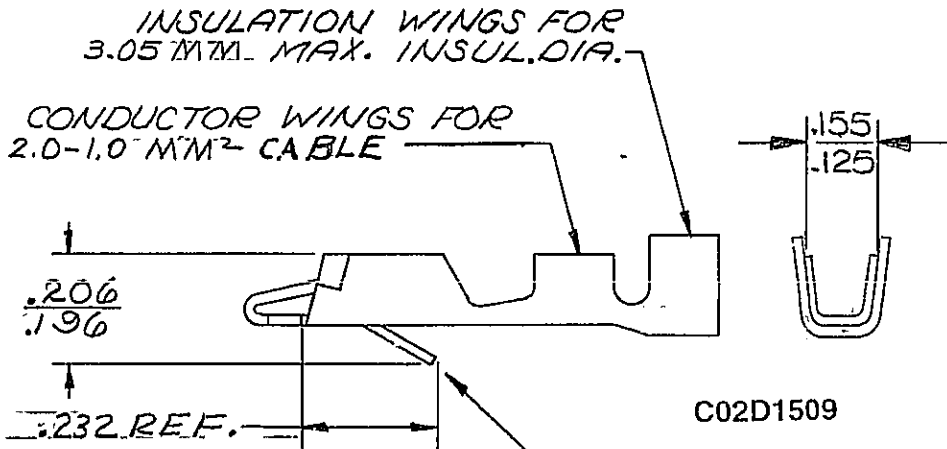
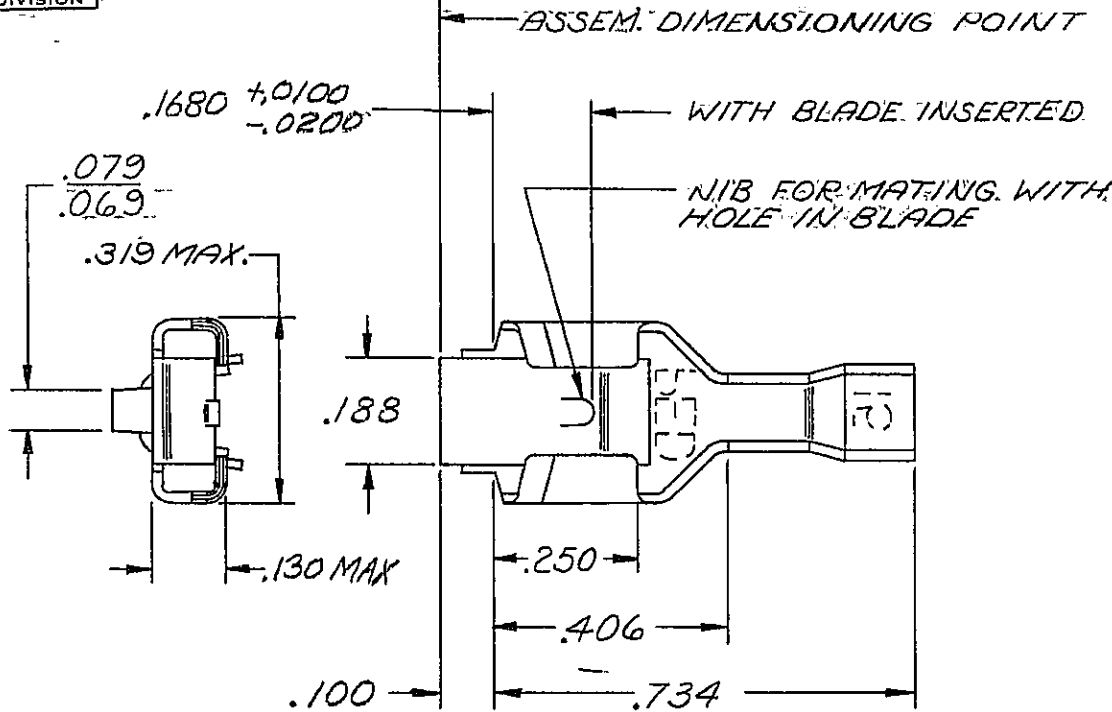

TANG FOR LOCKING TERMINAL IN CONNECTOR BODY

NOTE — TO FIT .032 X .250 BLADE.

**-OUTLINE DRAWING-**

|         |     |    |                      |        |        |          |
|---------|-----|----|----------------------|--------|--------|----------|
| PART NO |     |    | <b>02965142</b>      |        | SIZE   | <b>A</b> |
| DATE    | SYM | NP | REVISION             | RECORD | C/N    |          |
| 09JA86  | -   |    | ALL PREVIOUS DATA    |        |        |          |
|         |     |    | REMOVED FROM REV.    |        |        |          |
|         |     |    | COLUMN; .232 REF WAS |        |        |          |
|         |     |    | .240/.224            |        | 103378 |          |
| 23AU93  | -   |    | REVISED              |        | 157111 |          |
| 23AU93  | -   |    | REVISED              |        | 157151 |          |
| 07AU01  | CC  | 1  | UPDATED REV LEVEL    |        | 212097 |          |

|  |                           |                                      |                        |
|--|---------------------------|--------------------------------------|------------------------|
| CODE NO. <b>6900</b>   |                           | TOLERANCE UNLESS OTHERWISE SPECIFIED |                        |
|  |                           | DECIMAL                              | ± .010                 |
|  |                           | FRACTIONAL                           | ±                      |
|  |                           | ANGULAR                              | ±                      |
| DWG DATE <b>4-19-56</b>  | SCALE <b>NONE</b>         | DR.                                  | <b>PLYLER</b>          |
| ROUTING  |                           | CK                                   | <b>Peace 2-16-60</b>   |
| DEPT   |                           | APPR.                                |                        |
| OUTST.   |                           | APPR                                 | <b>Howards 2-16-60</b> |
| REFERENCE  | <b>2962874-D SHEET #1</b> | APPR                                 | <b>R.E. Kirk 2-23</b>  |
| MATERIAL SPEC. <b>.0180 THK SAE CA 260 BRASS 1/2 HARD TIN PLATED</b> |                           |                                      | CODE NO.               |
| NAME <b>TERMINAL-FEMALE-56 SERIES</b>                                |                           |                                      |                        |
| PART NO.   |                           |                                      | SIZE                   |
| <b>02965142</b>  |                           |                                      | <b>A</b>               |