

OSRAM KW DPLS31.KB

Datasheet

Not for new design

Published by ams-OSRAM AG

Tobelbader Strasse 30, 8141 Premstaetten, Austria

Phone +43 3136 500-0

ams-osram.com

© All rights reserved



SYNIOS® E4014

KW DPLS31.KB

This compact LED offers an extremely low-profile and compact design of 4.0 x 1.4 x 0.65 mm, uniform distribution of light and rugged plastic housing.



Applications

- Display Backlighting

Features

- Package: SMD epoxy package, colored silicone resin
- Chip technology: InGaN on Sapphire
- Typ. Radiation: 120° (Lambertian emitter)
- Color: $C_x = 0.28$, $C_y = 0.26$ acc. to CIE 1931 (● white)
- Optical efficacy: 110 lm/W
- Corrosion Robustness Class: 1B
- Qualifications: The product qualification test plan is based on the guidelines of AEC-Q101-REV-C, Stress Test Qualification for Automotive Grade Discrete Semiconductors.
- ESD: 2 kV acc. to ANSI/ESDA/JEDEC JS-001 (HBM, Class 2)

Ordering Information

Type	Luminous Flux ¹⁾ $I_F = 120 \text{ mA}$ Φ_V	Ordering Code
KW DPLS31.KB-65H5J-G4P7-UV-24A4	34.0 ... 50.0 lm	Q65112A3770

Maximum Ratings

Parameter	Symbol	Values	
Operating Temperature	T_{op}	min.	-40 °C
		max.	100 °C
Storage Temperature	T_{stg}	min.	-40 °C
		max.	100 °C
Junction Temperature	T_j	max.	125 °C
Forward current $T_s = 25\text{ °C}$	I_F	min.	10 mA
		max.	180 mA
ESD withstand voltage acc. to ANSI/ESDA/JEDEC JS-001 (HBM, Class 2)	V_{ESD}		2 kV
Reverse voltage ²⁾	V_R		Not designed for reverse operation

Characteristics

$I_F = 120 \text{ mA}$; $T_s = 25 \text{ °C}$

Parameter	Symbol		Values
Chromaticity Coordinate ³⁾	C_x	typ.	0.28
	C_y	typ.	0.26
Peak Wavelength $I_F = 120 \text{ mA}$	λ_{peak}	min.	446 nm
		max.	454 nm
Viewing angle at 50% I_v	2ϕ	typ.	120 °
Forward Voltage ⁴⁾ $I_F = 120 \text{ mA}$	V_F	min.	2.80 V
		typ.	3.10 V
		max.	3.40 V
Reverse current ²⁾	I_R		Not designed for reverse operation
Real thermal resistance junction/solderpoint ⁵⁾	$R_{\text{thJS real}}$	typ. max.	19 K / W 25 K / W
Electrical thermal resistance junction/solderpoint ⁵⁾ with efficiency $\eta_e = 42 \%$	$R_{\text{thJS elec.}}$	typ. max.	11 K / W 15 K / W

Brightness Groups

Group	Luminous Flux ¹⁾ $I_F = 120 \text{ mA}$ min. Φ_V	Luminous Flux ¹⁾ $I_F = 120 \text{ mA}$ max. Φ_V	Luminous Intensity ⁶⁾ $I_F = 120 \text{ mA}$ typ. I_V
65H	34.0 lm	35.5 lm	11.9 cd
7H	35.5 lm	40.0 lm	12.9 cd
8H	40.0 lm	45.0 lm	14.5 cd
5J	45.0 lm	50.0 lm	16.2 cd

Forward Voltage Groups

Group	Forward Voltage ⁴⁾ $I_F = 120 \text{ mA}$ min. V_F	Forward Voltage ⁴⁾ $I_F = 120 \text{ mA}$ max. V_F
24	2.80 V	3.00 V
64	3.00 V	3.20 V
A4	3.20 V	3.40 V

Wavelength Groups

Group	Peak Wavelength $I_F = 120 \text{ mA}$ min. λ_{peak}	Peak Wavelength $I_F = 120 \text{ mA}$ max. λ_{peak}
U	446 nm	451 nm
V	448 nm	454 nm

Chromaticity Coordinate Groups

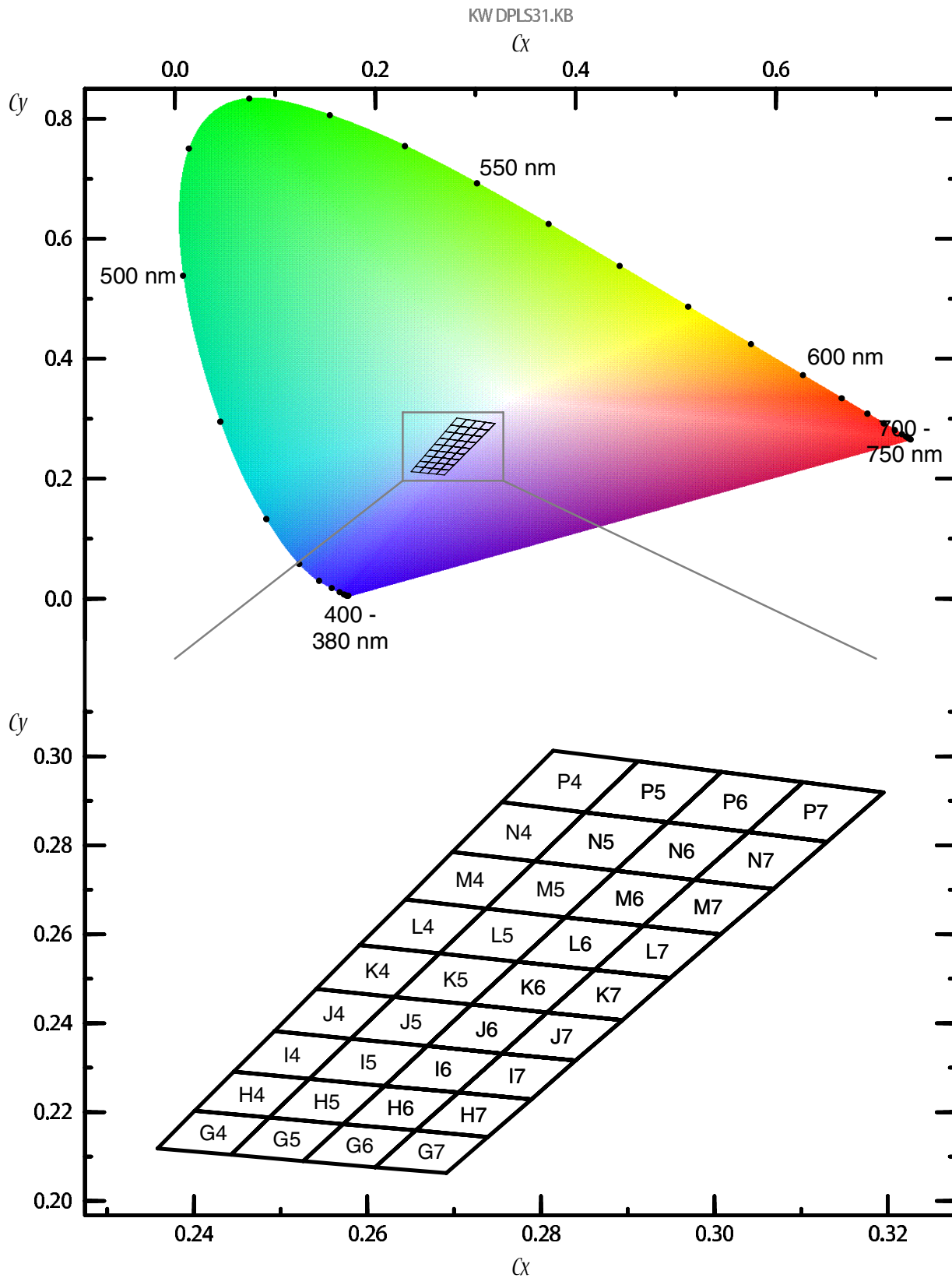

Not for new design

Chromaticity Coordinate Groups ³⁾

Group	Cx	Cy	Group	Cx	Cy	Group	Cx	Cy
G4	0.2358	0.2118	I4	0.2446	0.2291	K4	0.2541	0.2477
	0.2443	0.2104		0.2533	0.2275		0.2631	0.2459
	0.2487	0.2188		0.2581	0.2365		0.2683	0.2557
	0.2401	0.2203		0.2493	0.2382		0.2591	0.2576
G5	0.2443	0.2104	I5	0.2533	0.2275	K5	0.2631	0.2459
	0.2526	0.2090		0.2620	0.2259		0.2720	0.2442
	0.2572	0.2173		0.2669	0.2349		0.2773	0.2538
	0.2487	0.2188		0.2581	0.2365		0.2683	0.2557
G6	0.2526	0.2090	I6	0.2620	0.2259	K6	0.2720	0.2442
	0.2609	0.2076		0.2705	0.2244		0.2807	0.2424
	0.2656	0.2159		0.2755	0.2332		0.2862	0.2520
	0.2572	0.2173		0.2669	0.2349		0.2773	0.2538
G7	0.2609	0.2076	I7	0.2705	0.2244	K7	0.2807	0.2424
	0.2691	0.2063		0.2789	0.2229		0.2894	0.2407
	0.2739	0.2144		0.2840	0.2316		0.2949	0.2502
	0.2656	0.2159		0.2755	0.2332		0.2862	0.2520
H4	0.2401	0.2203	J4	0.2493	0.2382	L4	0.2591	0.2576
	0.2487	0.2188		0.2581	0.2365		0.2683	0.2557
	0.2533	0.2275		0.2631	0.2459		0.2737	0.2658
	0.2446	0.2291		0.2541	0.2477		0.2644	0.2678
H5	0.2487	0.2188	J5	0.2581	0.2365	L5	0.2683	0.2557
	0.2572	0.2173		0.2669	0.2349		0.2773	0.2538
	0.2620	0.2259		0.2720	0.2442		0.2828	0.2638
	0.2533	0.2275		0.2631	0.2459		0.2737	0.2658
H6	0.2572	0.2173	J6	0.2669	0.2349	L6	0.2773	0.2538
	0.2656	0.2159		0.2755	0.2332		0.2862	0.2520
	0.2705	0.2244		0.2807	0.2424		0.2918	0.2619
	0.2620	0.2259		0.2720	0.2442		0.2828	0.2638
H7	0.2656	0.2159	J7	0.2755	0.2332	L7	0.2862	0.2520
	0.2739	0.2144		0.2840	0.2316		0.2949	0.2502
	0.2789	0.2229		0.2894	0.2407		0.3007	0.2600
	0.2705	0.2244		0.2807	0.2424		0.2918	0.2619

Not for new design

Group	Cx	Cy	Group	Cx	Cy	Group	Cx	Cy
M4	0.2644	0.2678	N4	0.2698	0.2785	P4	0.2755	0.2897
	0.2737	0.2658		0.2793	0.2764		0.2851	0.2874
	0.2793	0.2764		0.2851	0.2874		0.2912	0.2989
	0.2698	0.2785		0.2755	0.2897		0.2814	0.3013
M5	0.2737	0.2658	N5	0.2793	0.2764	P5	0.2851	0.2874
	0.2828	0.2638		0.2886	0.2743		0.2946	0.2852
	0.2886	0.2743		0.2946	0.2852		0.3008	0.2965
	0.2793	0.2764		0.2851	0.2874		0.2912	0.2989
M6	0.2828	0.2638	N6	0.2886	0.2743	P6	0.2946	0.2852
	0.2918	0.2619		0.2977	0.2722		0.3039	0.2830
	0.2977	0.2722		0.3039	0.2830		0.3102	0.2942
	0.2886	0.2743		0.2946	0.2852		0.3008	0.2965
M7	0.2918	0.2619	N7	0.2977	0.2722	P7	0.3039	0.2830
	0.3007	0.2600		0.3068	0.2702		0.3130	0.2808
	0.3068	0.2702		0.3130	0.2808		0.3195	0.2919
	0.2977	0.2722		0.3039	0.2830		0.3102	0.2942

Group Name on Label

Example: 5J-G4-U-24

Brightness	Color Chromaticity	Wavelength Groups	Forward Voltage
5J	G4	U	24

Relative Spectral Emission ⁶⁾

$\Phi_{rel} = f(\lambda); I_F = 120 \text{ mA}; T_S = 25 \text{ }^\circ\text{C}$

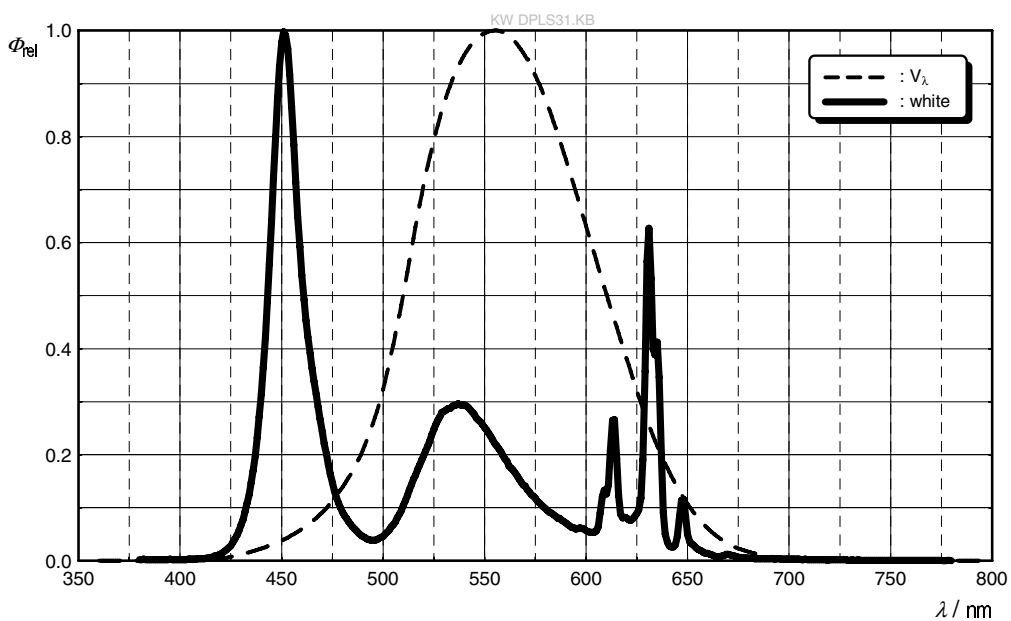

Radiation Characteristics ⁶⁾

$I_{rel} = f(\phi); T_S = 25 \text{ }^\circ\text{C}$

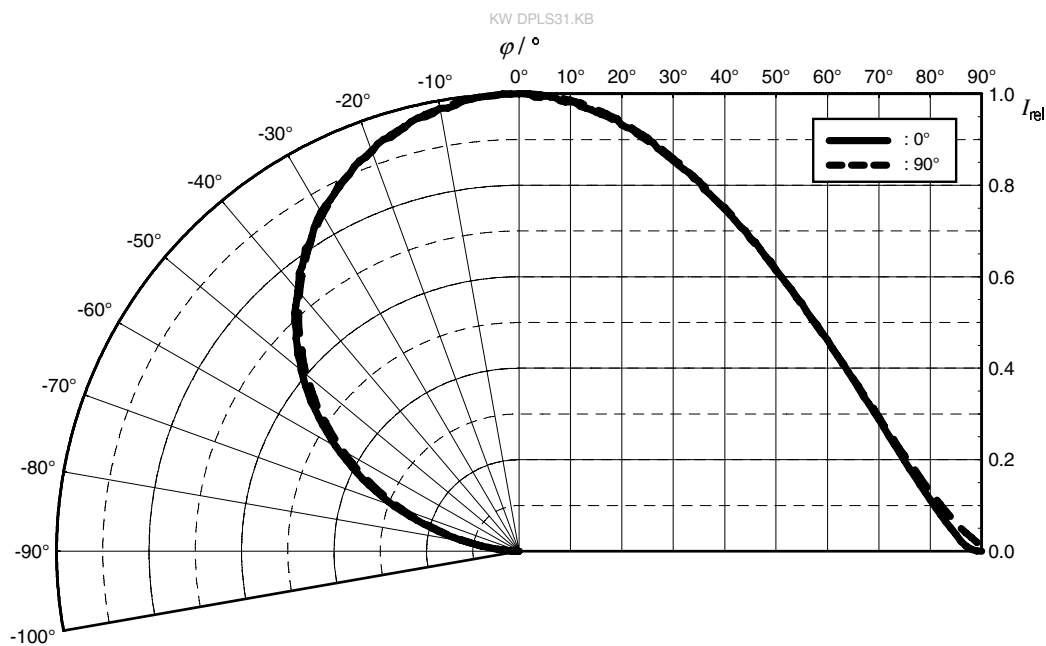

Not for new design

Forward current ⁶⁾

$$I_F = f(V_F); T_S = 25\text{ °C}$$

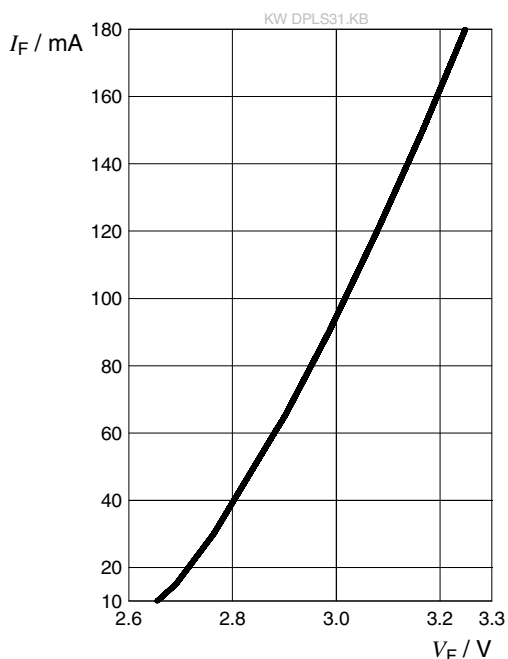

Relative Luminous Flux ^{6), 7)}

$$\Phi_V / \Phi_V(120\text{ mA}) = f(I_F); T_S = 25\text{ °C}$$

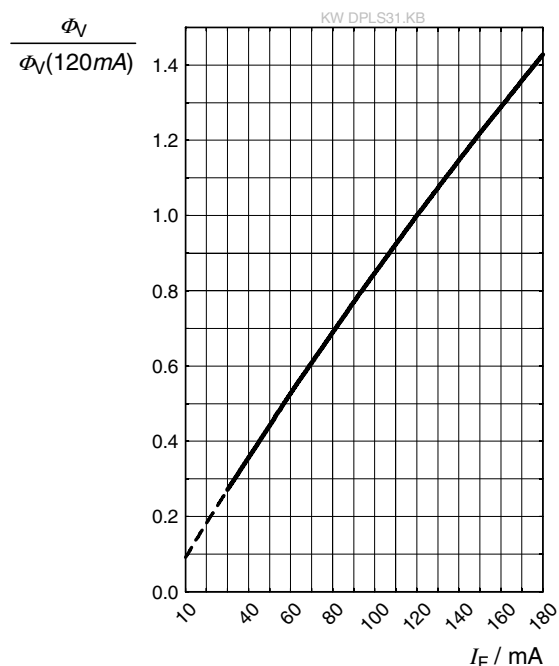

Chromaticity Coordinate Shift ⁶⁾

$$\Delta Cx, \Delta Cy = f(I_F); T_S = 25\text{ °C}$$

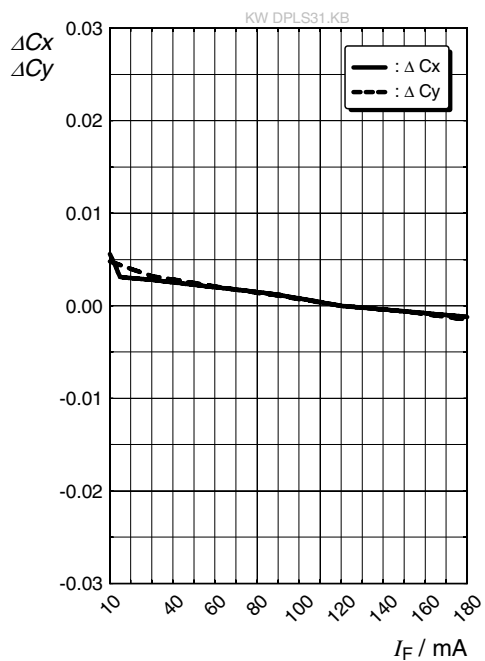

Forward Voltage ⁶⁾

$$\Delta V_F = V_F - V_F(25\text{ }^\circ\text{C}) = f(T_j); I_F = 120\text{ mA}$$

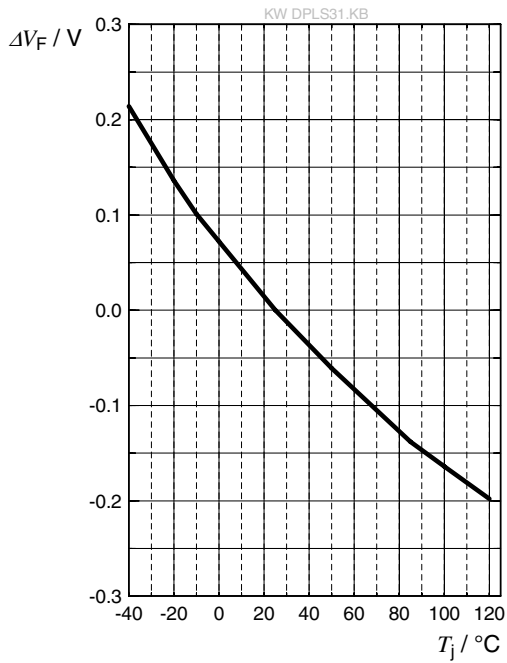

Relative Luminous Flux ⁶⁾

$$\Phi_V / \Phi_V(25\text{ }^\circ\text{C}) = f(T_j); I_F = 120\text{ mA}$$

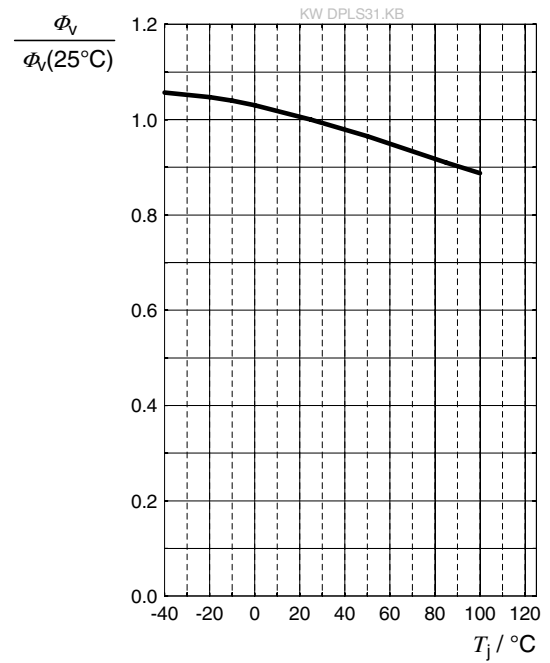

Chromaticity Coordinate Shift ⁶⁾

$$\Delta C_x, \Delta C_y = f(T_j); I_F = 120\text{ mA}$$

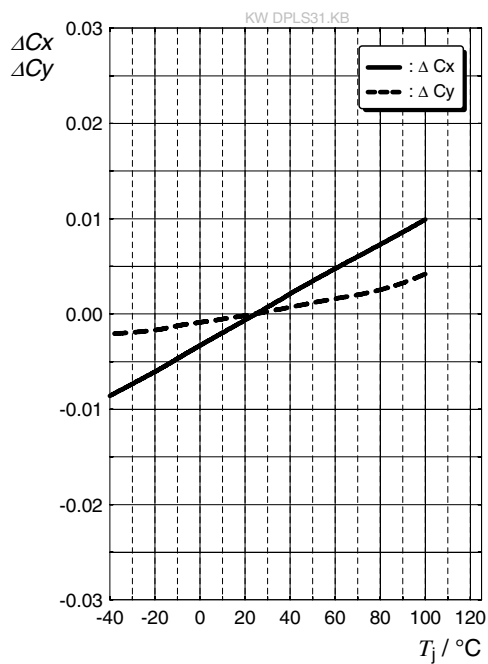

Not for new design

Max. Permissible Forward Current

$$I_F = f(T)$$

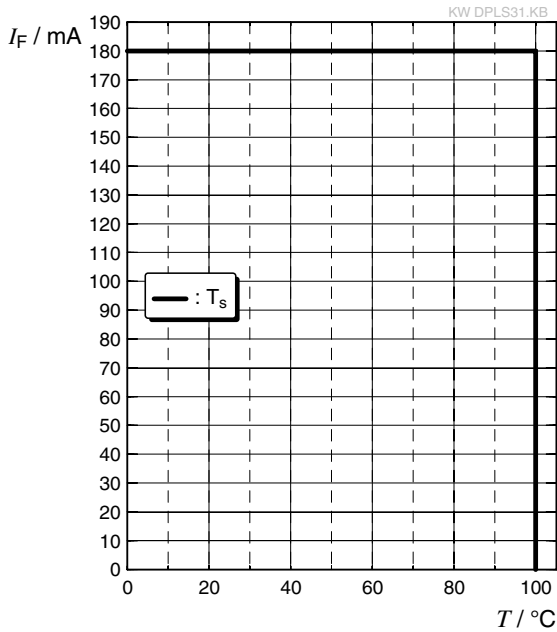

Permissible Pulse Handling Capability

$$I_F = f(t_p); D: \text{Duty cycle}$$

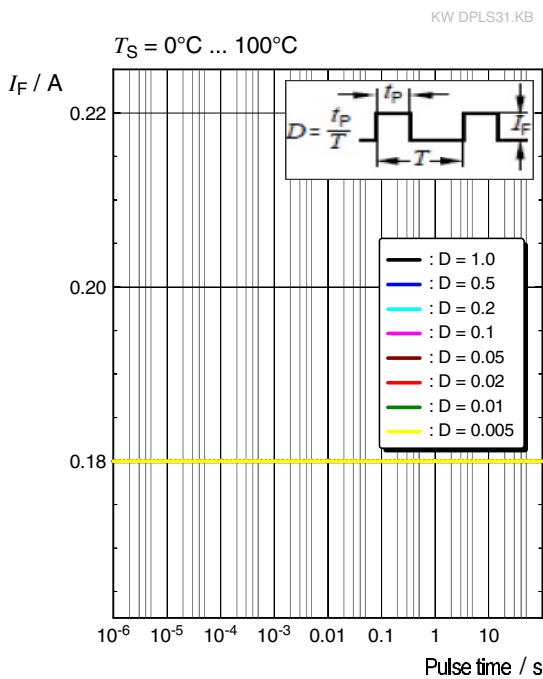

Not for new design

Dimensional Drawing ⁸⁾

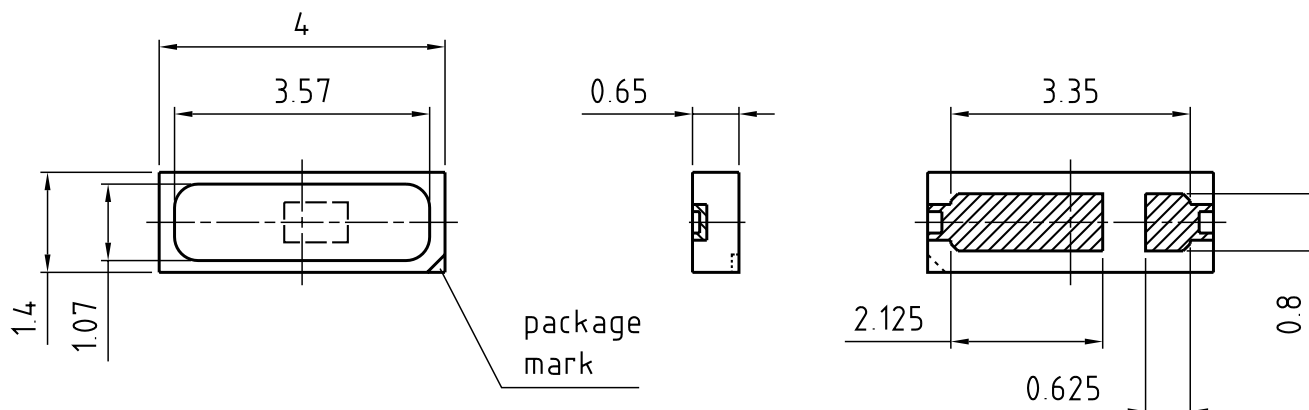

general tolerance ± 0.1
lead finish Ag 

C63062-A4353-A1.-02

Further Information:

Approximate Weight: 10.0 mg

Package marking: Cathode

Corrosion test: Class: 1B

Test condition: 25°C / 75 % RH / 200ppb SO₂, 200ppb NO₂, 10ppb H₂S,
10ppb Cl₂ / 21 days (EN 60068-2-60 (Method 4))

Electrical Internal Circuit

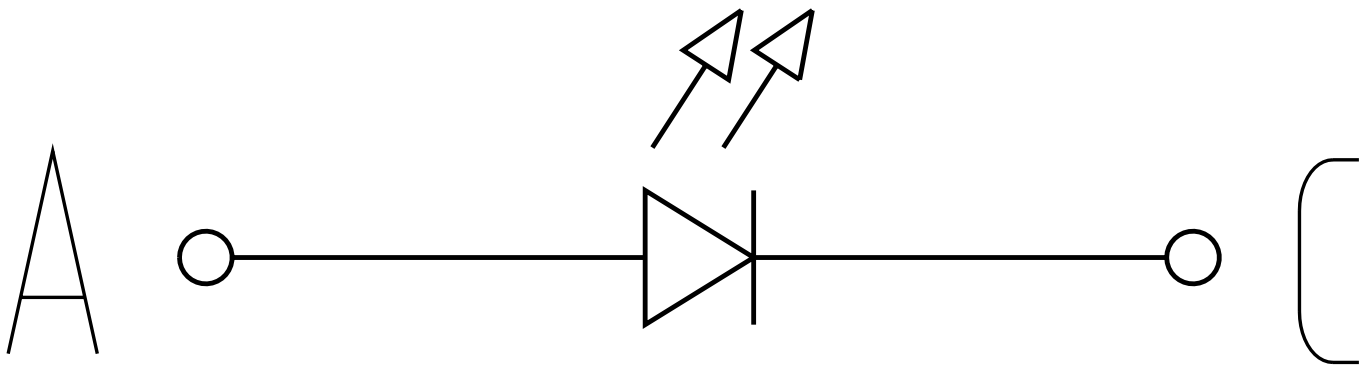

Recommended Solder Pad ⁸⁾

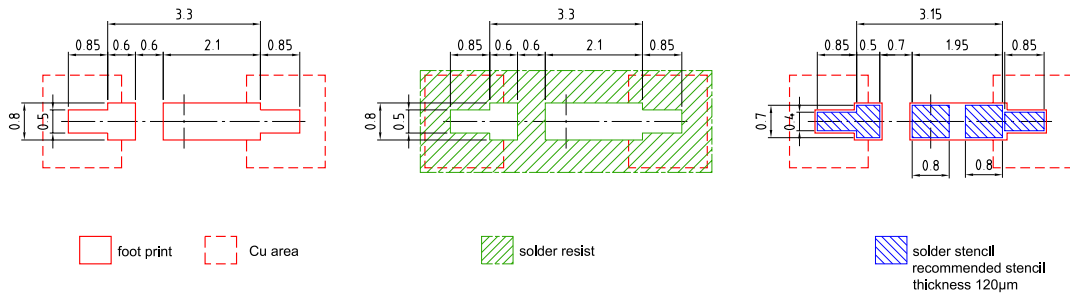

Component Location on Pad

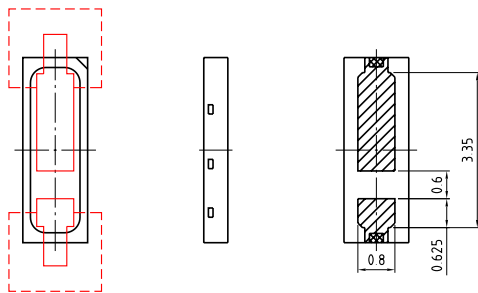

E062.3010.228-01

For superior solder joint connectivity results we recommend soldering under standard nitrogen atmosphere. Package not suitable for ultra sonic cleaning.

Reflow Soldering Profile

Product complies to MSL Level 3 acc. to JEDEC J-STD-020E

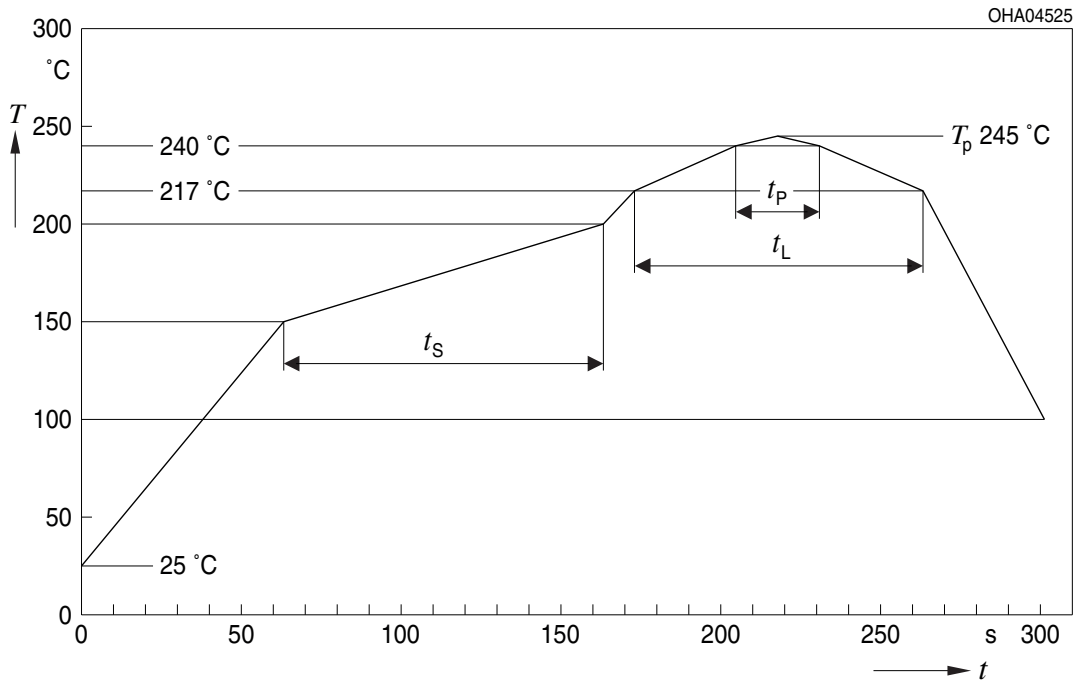

Profile Feature	Symbol	Pb-Free (SnAgCu) Assembly			Unit
		Minimum	Recommendation	Maximum	
Ramp-up rate to preheat ^{*)} 25 °C to 150 °C			2	3	K/s
Time t_s T_{Smin} to T_{Smax}	t_s	60	100	120	s
Ramp-up rate to peak ^{*)} T_{Smax} to T_p			2	3	K/s
Liquidus temperature	T_L		217		°C
Time above liquidus temperature	t_L		80	100	s
Peak temperature	T_p		245	260	°C
Time within 5 °C of the specified peak temperature $T_p - 5$ K	t_p	10	20	30	s
Ramp-down rate* T_p to 100 °C			3	6	K/s
Time 25 °C to T_p				480	s

All temperatures refer to the center of the package, measured on the top of the component
^{*)} slope calculation DT/Dt : Dt max. 5 s; fulfillment for the whole T-range

Not for new design

Taping ⁸⁾

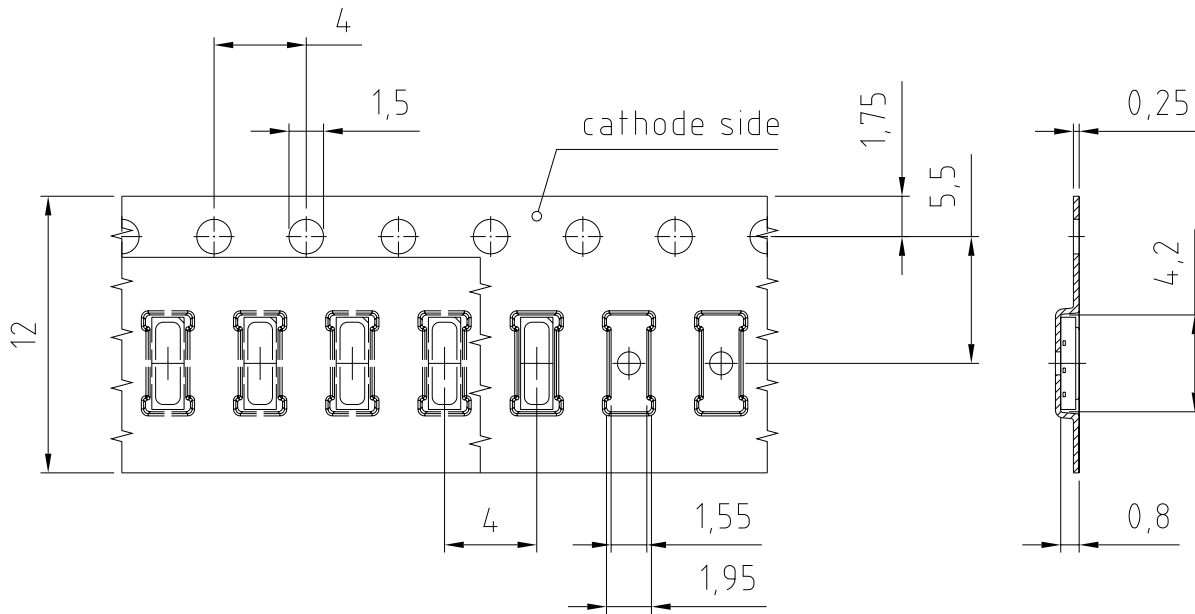

C63062-A4353-B6-01

Tape and Reel ⁹⁾

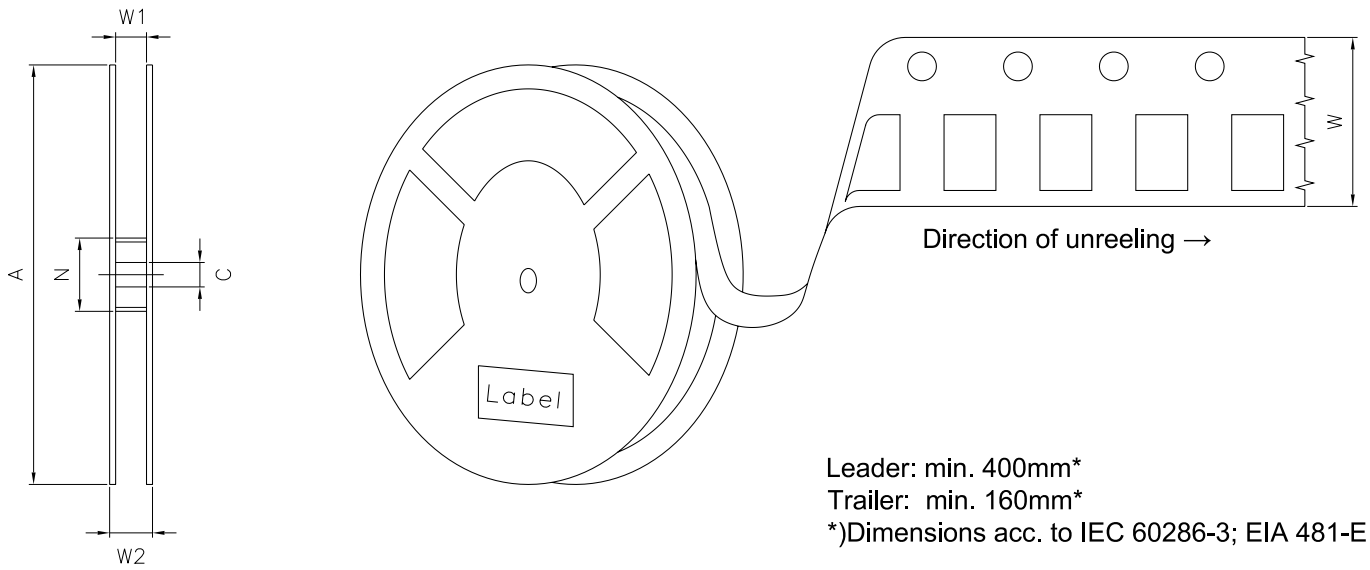

Reel Dimensions

A	W	N _{min}	W ₁	W _{2max}	Pieces per PU
180 mm	12 + 0.3 / - 0.1 mm	60 mm	12.4 + 2 mm	18.4 mm	4500

Barcode-Product-Label (BPL)



OSRAM Opto Semiconductors LX XXXX BIN1: XX-XX-X-XXX-X

RoHS Compliant

(6P) BATCH NO: 1234567890 ML Temp ST
X XXX °C X

(1T) LOT NO: 1234567890 (9D) D/C: 1234

Pack: RXX
DEMY XXX
X_X123_1234.1234 X

(X) PROD NO: 123456789(Q)QTY: 9999 (G) GROUP: XX-XX-X-X

OHA04563

Dry Packing Process and Materials ⁸⁾

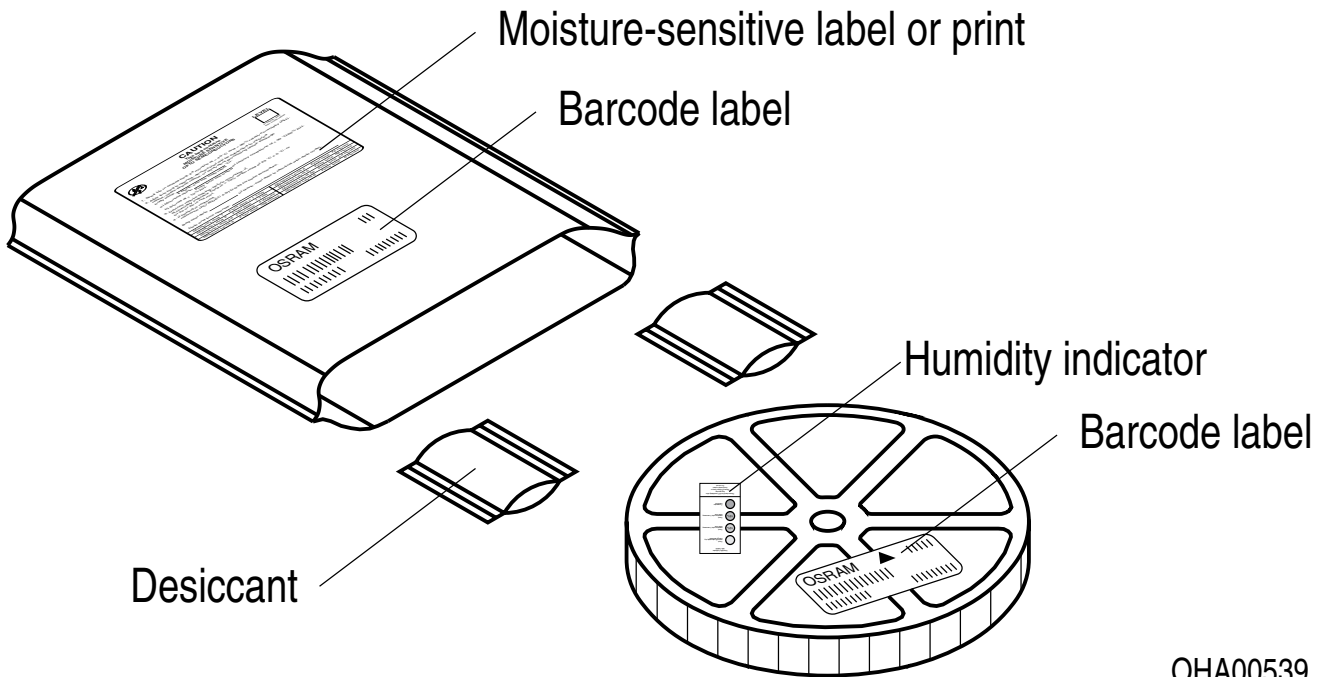

OHA00539

Moisture-sensitive product is packed in a dry bag containing desiccant and a humidity card according JEDEC-STD-033.

Not for new design

Notes

The evaluation of eye safety occurs according to the standard IEC 62471:2006 (photo biological safety of lamps and lamp systems). Within the risk grouping system of this IEC standard, the device specified in this data sheet fall into the class **moderate risk (exposure time 0.25 s)**. Under real circumstances (for exposure time, conditions of the eye pupils, observation distance), it is assumed that no endangerment to the eye exists from these devices. As a matter of principle, however, it should be mentioned that intense light sources have a high secondary exposure potential due to their blinding effect. When looking at bright light sources (e.g. headlights), temporary reduction in visual acuity and afterimages can occur, leading to irritation, annoyance, visual impairment, and even accidents, depending on the situation.

Subcomponents of this device contain, in addition to other substances, metal filled materials including silver. Metal filled materials can be affected by environments that contain traces of aggressive substances. Therefore, we recommend that customers minimize device exposure to aggressive substances during storage, production, and use. Devices that showed visible discoloration when tested using the described tests above did show no performance deviations within failure limits during the stated test duration. Respective failure limits are described in the IEC60810.

For further application related information please visit www.osram-os.com/appnotes

Disclaimer

Attention please!

The information describes the type of component and shall not be considered as assured characteristics. Terms of delivery and rights to change design reserved. Due to technical requirements components may contain dangerous substances.

For information on the types in question please contact our Sales Organization.

If printed or downloaded, please find the latest version on our website.

Packing

Please use the recycling operators known to you. We can also help you – get in touch with your nearest sales office. By agreement we will take packing material back, if it is sorted. You must bear the costs of transport. For packing material that is returned to us unsorted or which we are not obliged to accept, we shall have to invoice you for any costs incurred.

Product and functional safety devices/applications or medical devices/applications

Our components are not developed, constructed or tested for the application as safety relevant component or for the application in medical devices.

Our products are not qualified at module and system level for such application.

In case buyer – or customer supplied by buyer – considers using our components in product safety devices/ applications or medical devices/applications, buyer and/or customer has to inform our local sales partner immediately and we and buyer and /or customer will analyze and coordinate the customer-specific request between us and buyer and/or customer.

Glossary

- 1) **Brightness:** Brightness values are measured during a current pulse of typically 60 ms, with an internal reproducibility of $\pm 8\%$ and an expanded uncertainty of $\pm 11\%$ (acc. to GUM with a coverage factor of $k = 3$).
- 2) **Reverse Operation:** Not designed for reverse operation. Continuous reverse operation can cause migration and damage of the device.
- 3) **Chromaticity coordinate groups:** Chromaticity coordinates are measured during a current pulse of typically 60 ms, with an internal reproducibility of ± 0.005 and an expanded uncertainty of ± 0.01 (acc. to GUM with a coverage factor of $k = 3$).
- 4) **Forward Voltage:** The forward voltage is measured during a current pulse of typically 43 ms, with an internal reproducibility of $\pm 0.05\text{ V}$ and an expanded uncertainty of $\pm 0.1\text{ V}$ (acc. to GUM with a coverage factor of $k = 3$).
- 5) **Thermal Resistance:** $R_{th\ max}$ is based on statistic values (6σ).
- 6) **Typical Values:** Due to the special conditions of the manufacturing processes of semiconductor devices, the typical data or calculated correlations of technical parameters can only reflect statistical figures. These do not necessarily correspond to the actual parameters of each single product, which could differ from the typical data and calculated correlations or the typical characteristic line. If requested, e.g. because of technical improvements, these typ. data will be changed without any further notice.
- 7) **Characteristic curve:** In the range where the line of the graph is broken, you must expect higher differences between single devices within one packing unit.
- 8) **Tolerance of Measure:** Unless otherwise noted in drawing, tolerances are specified with ± 0.1 and dimensions are specified in mm.
- 9) **Tape and Reel:** All dimensions and tolerances are specified acc. IEC 60286-3 and specified in mm.

Revision History

Version	Date	Change
1.0	2019-04-24	Initial Version
1.1	2020-09-16	Features Schematic Transportation Box Dimensions of Transportation Box
1.2	2021-10-15	Features Reel Dimensions
1.3	2022-10-20	Applications Not for new design New Layout

Not for new design



EU RoHS and China RoHS compliant product

此产品符合欧盟 RoHS 指令的要求；
按照中国的相关法规和标准，
不含有毒有害物质或元素。

Published by ams-OSRAM AG

Tobelbader Strasse 30, 8141 Premstaetten, Austria

Phone +43 3136 500-0

ams-osram.com

© All rights reserved

am 

OSRAM