

# Ambient Light Sensor

## Version 1.0

---

### SFH 5701



#### Features:

- Analog output current is proportional to Ambient Light Intensity
- Spectral response close to human eye sensitivity
- Integrated dark current suppression
- Built in thermal compensation
- Linear response over 6 decades of illumination range

#### Applications

- Control of display backlighting
- Mobile devices
- Home automation/ smart speakers
- Smart TV
- Industrial displays
- Smart lighting control

#### Ordering Information

Type:	Output current $I_{OUT}$ [ $\mu A$ ] $V_{DD} = 5 V, E_V = 100 lx$ (white LED)	Ordering Code
SFH 5701	typ. 135	Q65112A5752

*Note:* Only one bin within one packing unit, see characteristics.

**Maximum Ratings** ( $T_A = 25\text{ °C}$ )

Parameter	Symbol	Values	Unit
Operation temperature range	$T_{op}$	-40 ... 85	°C
Storage temperature range	$T_{stg}$	-40 ... 85	°C
Supply voltage (for definition of voltage polarity refer to Appnote AN132)	$V_{DDmax}$	6	V
Supply current (internally limited; for definition refer to Appnote AN132)	$I_{DDmax}$	15	mA
Forward voltage (for definition of current polarity refer to Appnote AN132)	$V_F$	0.56	V
Forward current (for definition of voltage polarity refer to Appnote AN132)	$I_F$	0.5	mA
ESD withstand voltage (acc. to ANSI/ ESDA/ JEDEC JS-001 - HBM)	$V_{ESD}$	2000	V
ESD withstand voltage (acc. to ANSI/ ESDA/ JEDEC JS-002 - CDM)	$V_{ESD}$	750	V
ESD withstand voltage (acc. to ANSI/ ESDA/ JESD22-A115-MM)	$V_{ESD}$	400	V

**Operating Conditions**

Parameter	Symbol	Values			Unit
		min	typ	max	
Supply voltage (for the choice of $R_{LOAD}$ refer to Appnote AN132)	$V_{DD}$	1.45		5.5	V
Supply current ( $V_{DD} = 5\text{ V}$ , for the choice of $R_{LOAD}$ refer to Appnote AN132)	$I_{DD}$	0.01		10k	μA
Illuminance range	$E_V$	0.01		10k	lx

**Characteristics** ( $T_A = 25\text{ °C}$ )

Parameter	Symbol	Values	Unit
Spectral sensitivity ( $V_{DD} = 5\text{ V}$ , $E_V = 100\text{ lx}$ , white LED)	(typ) S	1	μA/ lx
Wavelength of max. sensitivity	(typ) $\lambda_{S\ max}$	600	nm
Spectral range of sensitivity	(min) $\lambda_{10\%}$	450	nm
	(max) $\lambda_{10\%}$	705	nm

Parameter		Symbol	Values	Unit
Dimensions of radiant sensitive area	(typ)	L x W	0.33 x 0.33	mm x mm
Half angle	(typ)	$\varphi$	$\pm 60$	$^{\circ}$
Output impedance	(typ)	$Z_{OUT}$	10	$M\Omega$
Forward voltage ( $I_F = 200 \mu A$ , $E = 0$ )	(typ)	$V_F$	0.52	V
Supply current ( $V_{DD} = 5 V$ , $E_V = 100 \text{ lx}$ (white LED))	(typ)	$I_{DD}$	135	$\mu A$
Output dark current ( $V_{DD} = 5 V$ , $E_V = 0 \text{ lx}$ )	(typ) (max)	$I_{OUT\_dark}$ $I_{OUT\_dark}$	3.4 50	nA nA
Rise time ( $R_{LOAD} = 33 \text{ k}\Omega$ , $E_V = 100 \text{ lx}$ , for different testing conditions refer to the Appnote AN132)	(typ)	$t_r$	14	ms
Temperature coefficient	(typ)	$T_{C\ IOUT}$	-0.07	%/K

### Relative Spectral Sensitivity <sup>1) page 12</sup>

Photodiode  $S_{rel} = f(\lambda)$

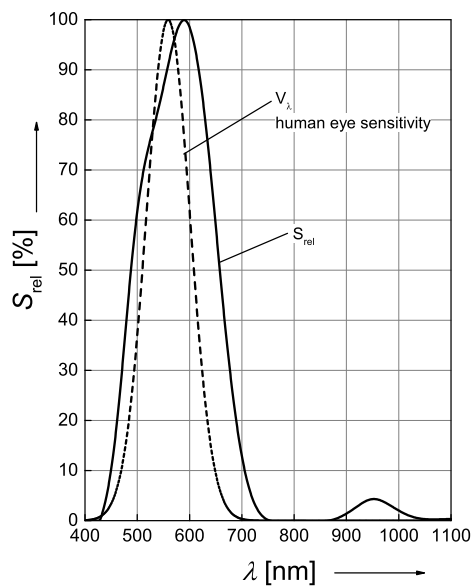

### Output Current <sup>1) page 12</sup>

$I_{OUT} = f(E_V)$ ; white LED;  $V_{DD} = 5 V$

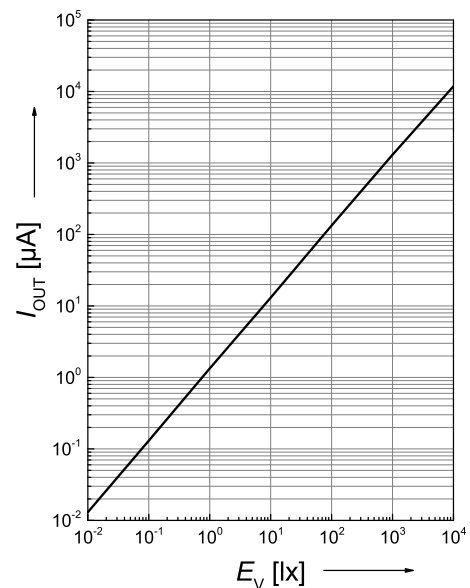

**Dark Current** <sup>1) page 12</sup>

$I_{\text{dark}} = f(V_{\text{DD}})$

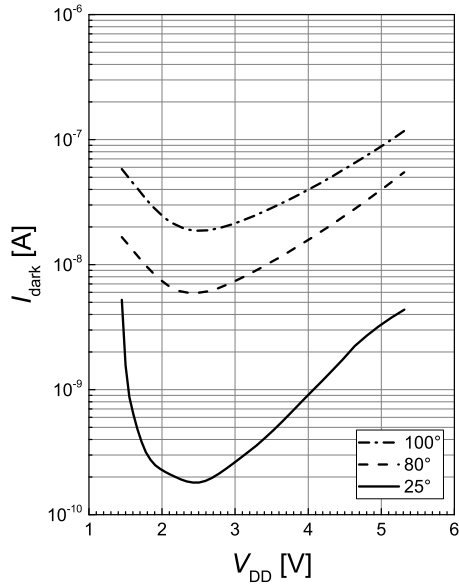

**Output Current** <sup>1) page 12</sup>

$I_{\text{OUT}}(T) / I_{\text{OUT}}(25^{\circ}\text{C}) = f(T_A)$ ;  $E_v = 100\text{lx}$ ; white LED;  $V_{\text{DD}} = 5\text{ V}$

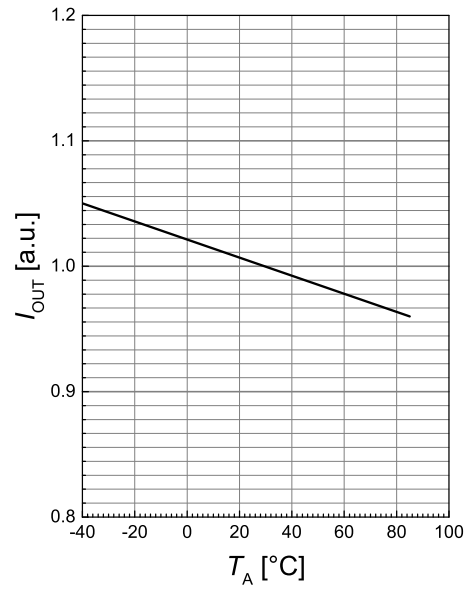

**Dark Current** <sup>1) page 12</sup>

$I_{\text{dark}} = f(T_A)$ ;  $V_F = 5\text{ V}$

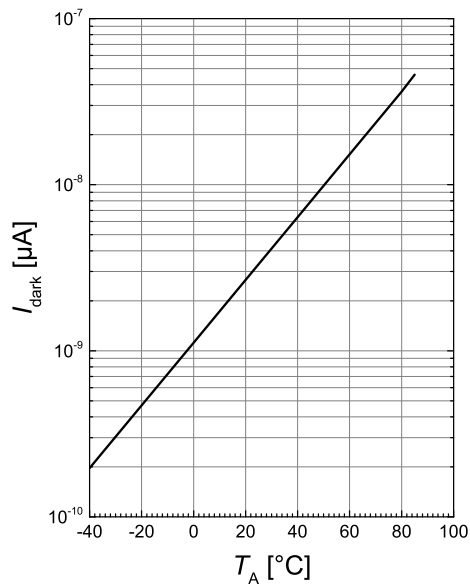

**Forward Current** <sup>1) page 12</sup>

$I_F = f(V_F)$ ;  $E = 0$

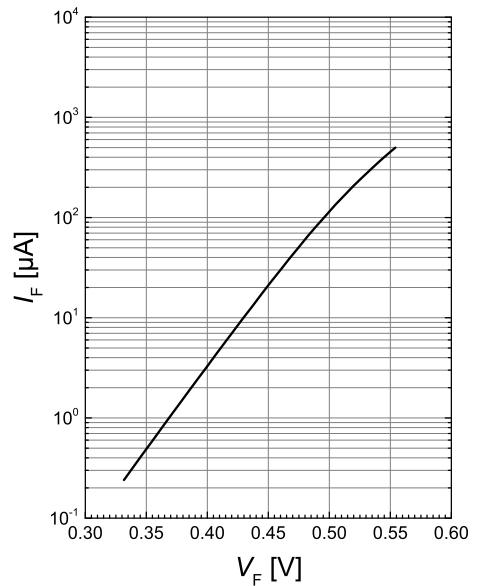

**Directional Characteristics (Horizontal)** <sup>1) page 12</sup>

Photodiode  $S_{rel} = f(\phi)$

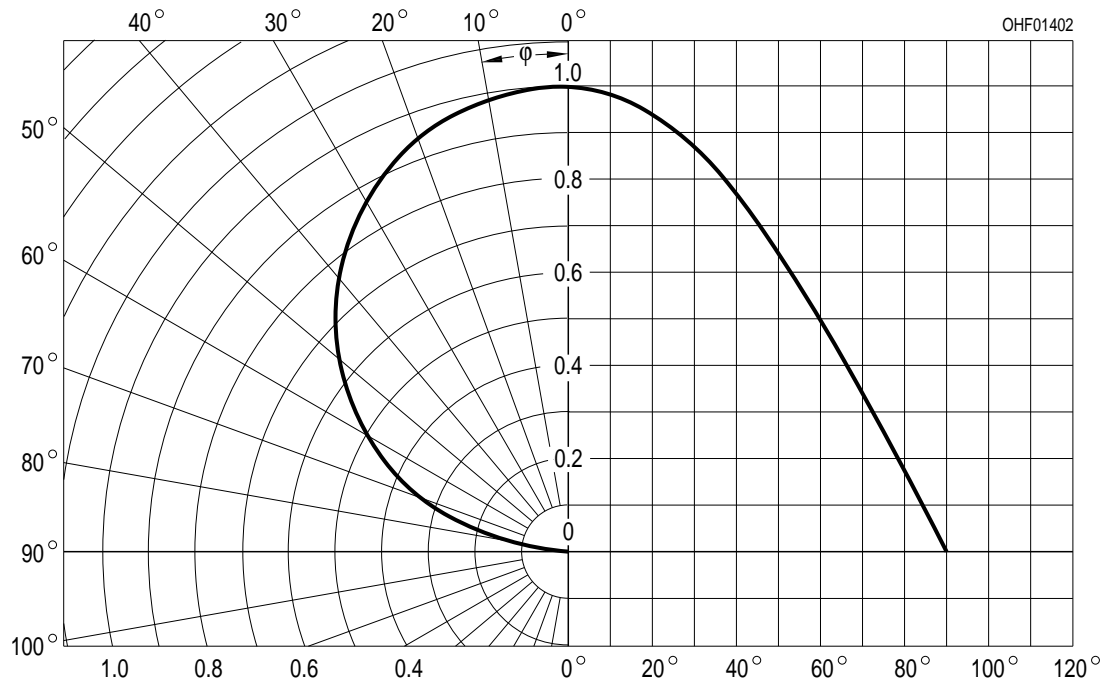

**Package Outline**

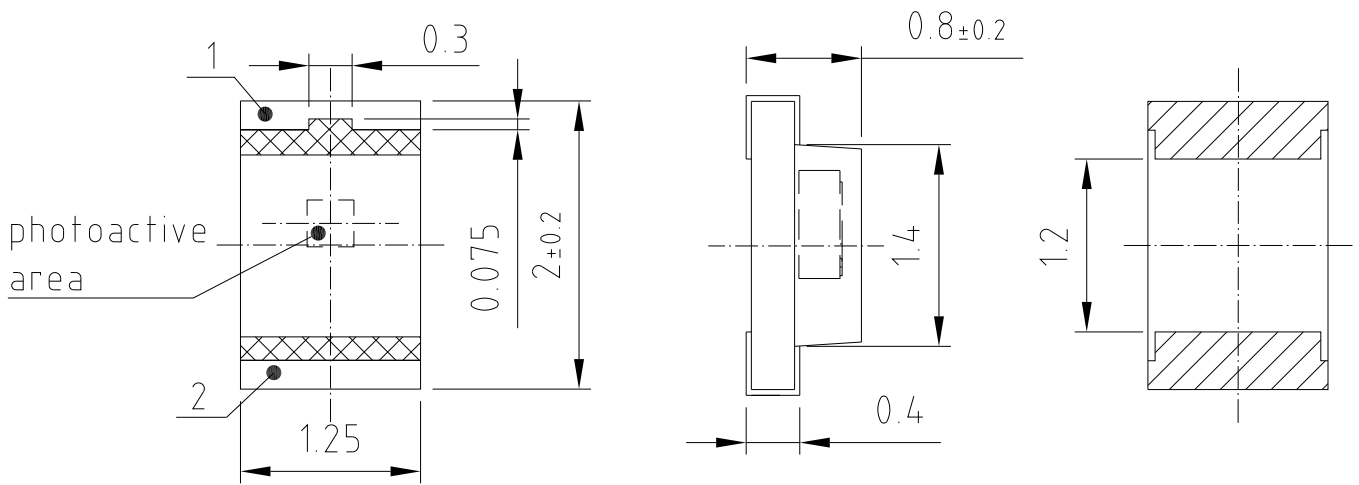

general tolerance  $\pm 0.1$   
 lead finish Au

C67062-A0260-A1KA-01

Dimensions in mm.

**Pinning**

Pin	Description
1	anode (OUT)
2	cathode (VDD)

**Approximate Weight:**

3.8 mg

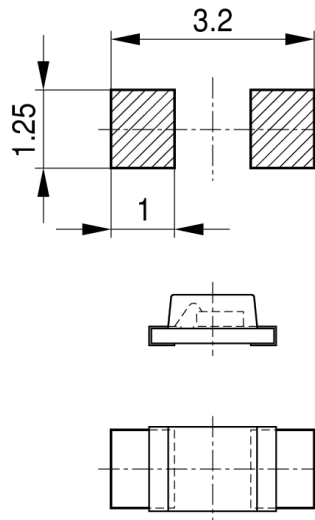
**Recommended Solder Pad**

Component location on pad

OHFP2578

Dimensions in mm.

## Reflow Soldering Profile

Product complies to MSL Level 4 acc. to JEDEC J-STD-020E

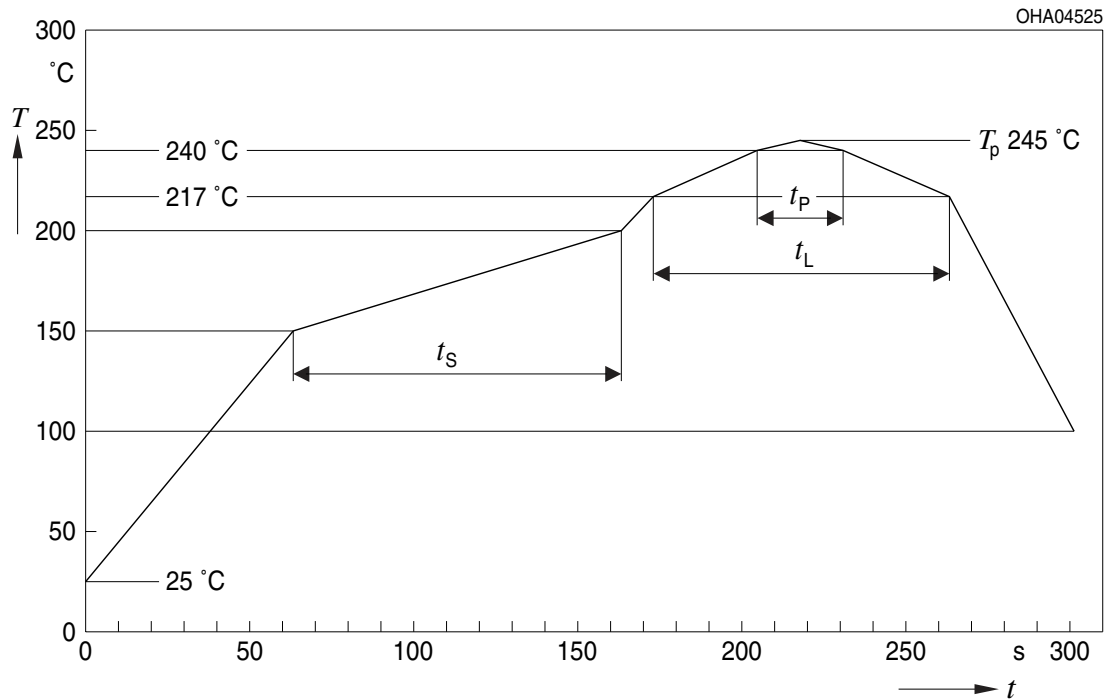

OHA04612

Profil-Charakteristik Profile Feature	Symbol Symbol	Pb-Free (SnAgCu) Assembly			Einheit Unit
		Minimum	Recommendation	Maximum	
Ramp-up Rate to Preheat*) 25 °C to 150 °C			2	3	K/s
Time $t_S$ $T_{Smin}$ to $T_{Smax}$	$t_S$	60	100	120	s
Ramp-up Rate to Peak*) $T_{Smax}$ to $T_P$			2	3	K/s
Liquidus Temperature	$T_L$	217			°C
Time above Liquidus temperature	$t_L$		80	100	s
Peak Temperature	$T_P$		245	260	°C
Time within 5 °C of the specified peak temperature $T_P - 5$ K	$t_p$	10	20	30	s
Ramp-down Rate* $T_P$ to 100 °C			3	6	K/s
Time 25 °C to $T_P$				480	s

All temperatures refer to the center of the package, measured on the top of the component

\* slope calculation  $DT/Dt$ :  $Dt$  max. 5 s; fulfillment for the whole T-range

Taping

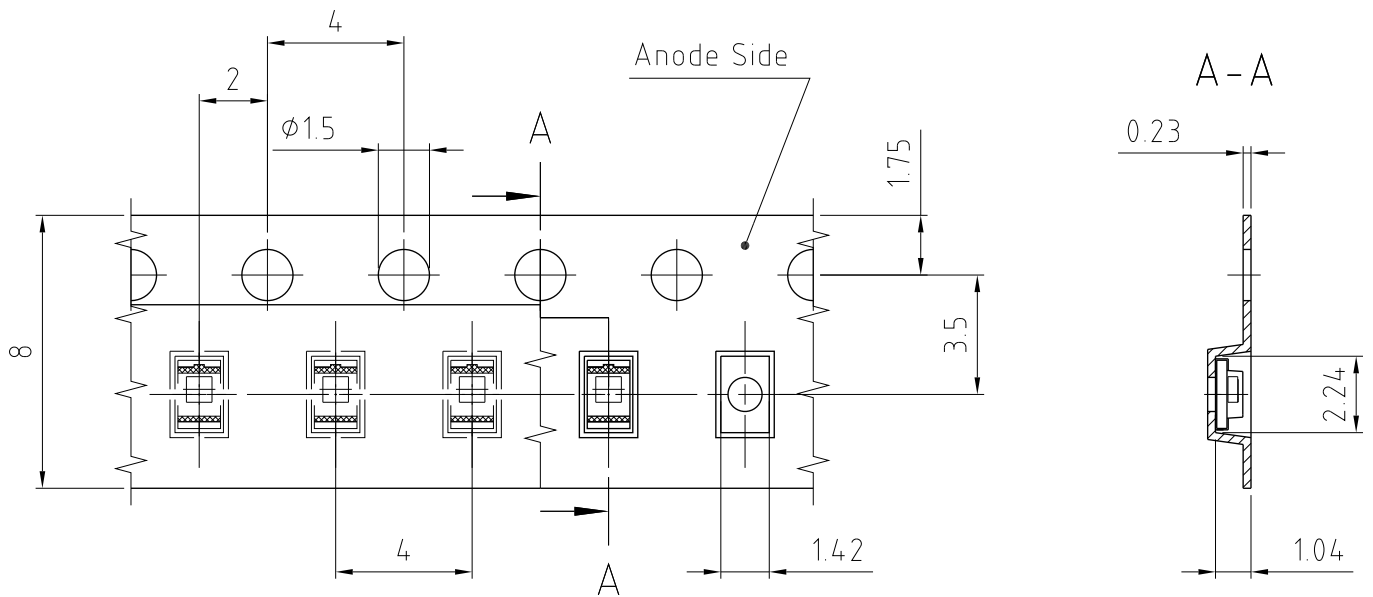

C67062-A0260-B1-03

Dimensions in mm.

Tape and Reel

8 mm tape with 3000 pcs. on  $\phi 180$  mm reel

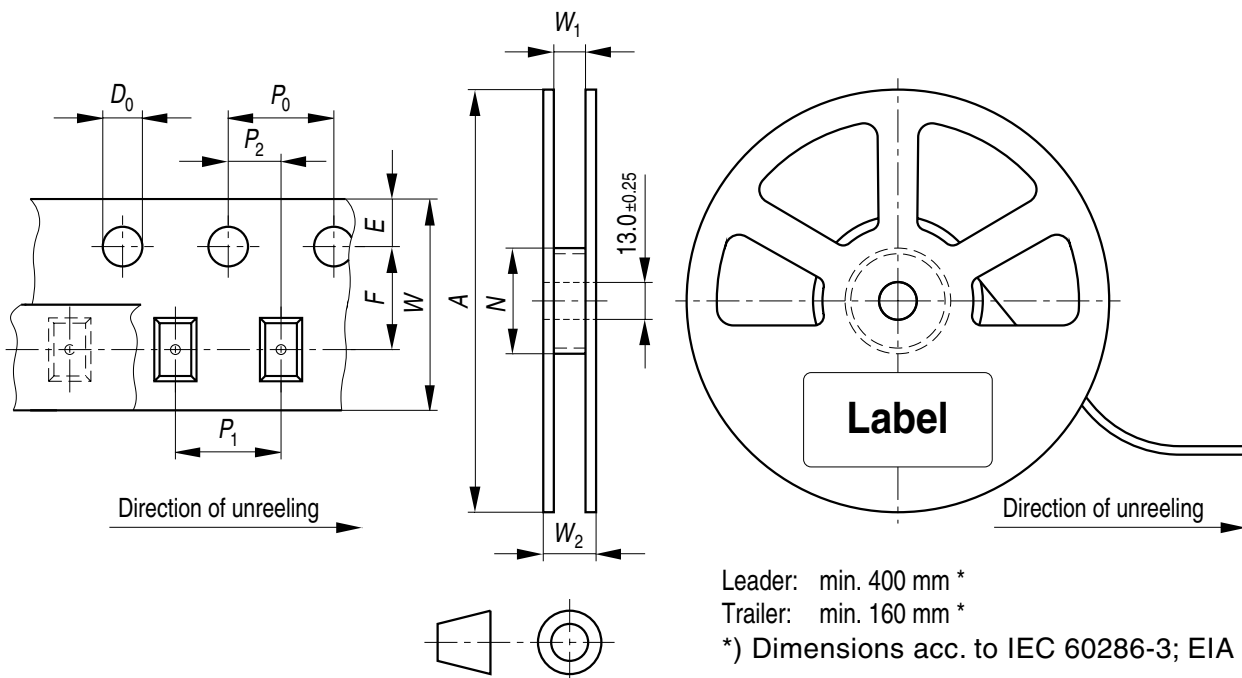



## Tape dimensions [mm]

W	P <sub>0</sub>	P <sub>1</sub>	P <sub>2</sub>	D <sub>0</sub>	E	F
8 + 0.3 / -0.1	4 ± 0.1	2 ± 0.05 or 4 ± 0.1	2 ± 0.05	1.5 ± 0.1	1.75 ± 0.1	3.5 ± 0.05

## Reel dimensions [mm]

A	W	N <sub>min</sub>	W <sub>1</sub>	W <sub>2max</sub>
180	8	60	8.4 + 2	14.4

## Barcode-Product-Label (BPL)

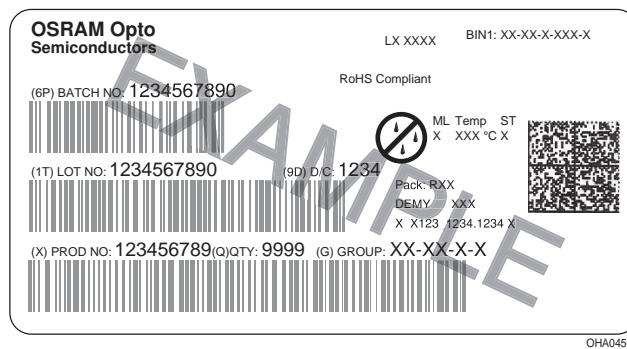

## Dry Packing Process and Materials

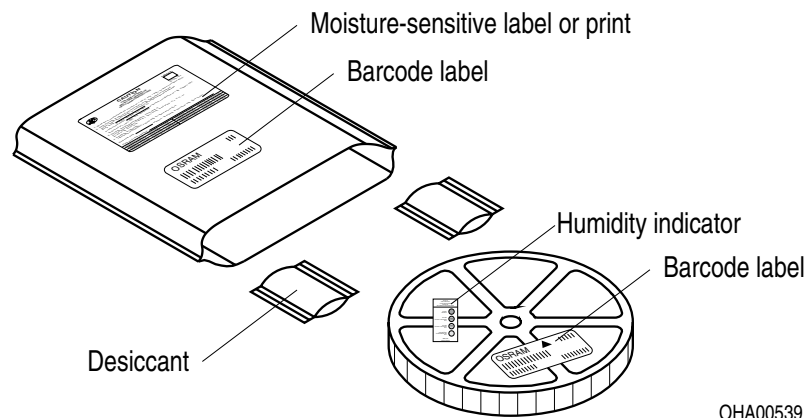

## Note:

Moisture-sensitive product is packed in a dry bag containing desiccant and a humidity card. Regarding dry pack you will find further information in the internet. Here you will also find the normative references like JEDEC.

## Transportation Packing and Materials

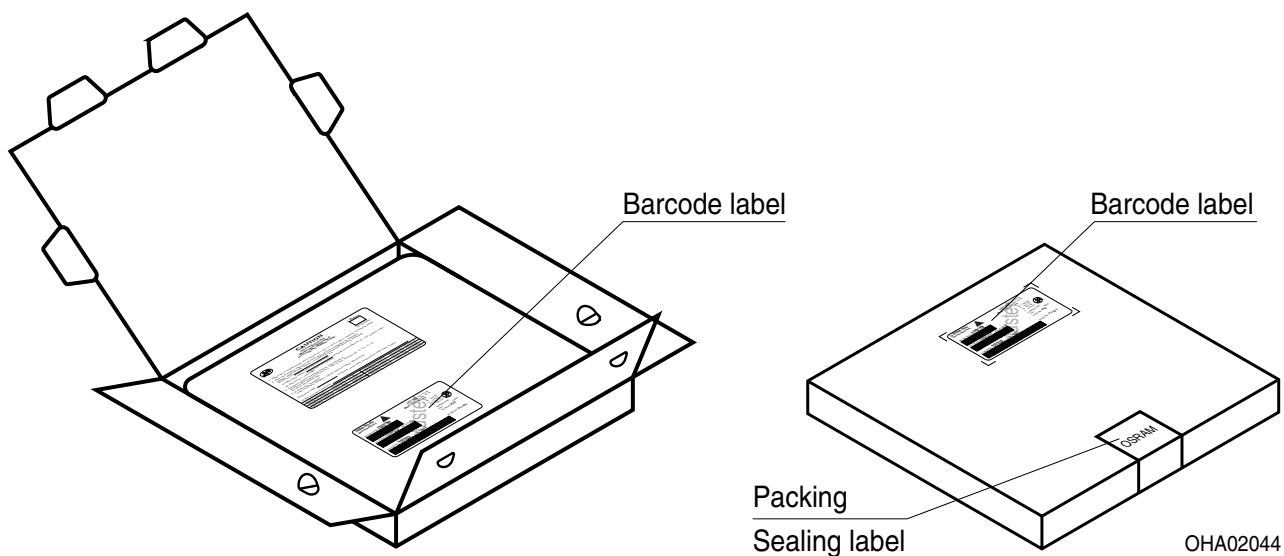

## Dimensions of transportation box in mm

Width	Length	Height
200 ± 5	195 ± 5	30 ± 5

**Disclaimer**

Language english will prevail in case of any discrepancies or deviations between the two language wordings.

**Attention please!**

The information describes the type of component and shall not be considered as assured characteristics.

Terms of delivery and rights to change design reserved. Due to technical requirements components may contain dangerous substances.

For information on the types in question please contact our Sales Organization. If printed or downloaded, please find the latest version in the Internet.

**Packing**

Please use the recycling operators known to you. We can also help you – get in touch with your nearest sales office. By agreement we will take packing material back, if it is sorted. You must bear the costs of transport. For packing material that is returned to us unsorted or which we are not obliged to accept, we shall have to invoice you for any costs incurred.

**Components used in life-support devices or systems must be expressly authorized for such purpose!**

Critical components\* may only be used in life-support devices\*\* or systems with the express written approval of OSRAM OS.

\*) A critical component is a component used in a life-support device or system whose failure can reasonably be expected to cause the failure of that life-support device or system, or to affect its safety or the effectiveness of that device or system.

\*\*) Life support devices or systems are intended (a) to be implanted in the human body, or (b) to support and/or maintain and sustain human life. If they fail, it is reasonable to assume that the health and the life of the user may be endangered.

## Glossary

- <sup>1)</sup> **Typical Values:** Due to the special conditions of the manufacturing processes of LED, the typical data or calculated correlations of technical parameters can only reflect statistical figures. These do not necessarily correspond to the actual parameters of each single product, which could differ from the typical data and calculated correlations or the typical characteristic line. If requested, e.g. because of technical improvements, these typ. data will be changed without any further notice.

Published by **OSRAM Opto Semiconductors GmbH**  
Leibnizstraße 4, D-93055 Regensburg  
[www.osram-os.com](http://www.osram-os.com) © All Rights Reserved.

EU RoHS and China RoHS compliant product



此产品符合欧盟 RoHS 指令的要求；  
按照中国的相关法规和标准，不含有毒有害物质或元素。