

# NLAS2066

## Ultra-Small Dual Single Pole, Single Throw Analog Switch with Over Voltage Tolerance

The NLAS2066 is a Dual SPST (Single Pole, Single Throw) Analog Switch high performance version of the popular NLAS323. Packaged in the ultra-small US8 package. It is designed as a general analog/digital switch and can also be used to isolate USB ports.

### Features

- Same Pinout as the Popular NLAS323
- Excellent Performance – Maximum  $R_{DS(ON)}$  15  $\Omega$  at 3.0 V
- Matching Between the Switches  $\pm 1.5 \Omega$  at 3.0 V
- 1.65 V to 5.5 V Operating Range
- Lower Threshold Voltages for LVTTTL/CMOS Levels
- Ultra-Low Charge Injection  $\leq 4.8$  pC at 3.0 V
- Low Standby Power –  $I_{CC} = 1.0$  nA (max) @  $T_A = 25^\circ\text{C}$
- CMOS Level Compatibility
- OVT\* (Pins 1, 3, 5, and 7) These Pins may be Subjected to 0 to +7.0 V, Regardless of Operating Voltage
- Allows a Short from USB Line without Damage to the Device
- Pb-Free Packages are Available\*\*

### Typical Applications

- USB Isolation
- Cell Phones
- PDAs
- MP3s Digital Still Cameras

### Important Information

- ESD Protection: Human Body Model; > 2000 V  
Machine Model; > 200 V
- Latch-Up Maximum Rating: 200 mA

\*Over Voltage Tolerance (OVT) enables pins to function outside (higher) of their operating voltages, with no damage to the devices or to signal integrity.

\*\*For additional information on our Pb-Free strategy and soldering details, please download the ON Semiconductor Soldering and Mounting Techniques Reference Manual, SOLDERRM/D.



ON Semiconductor®

<http://onsemi.com>

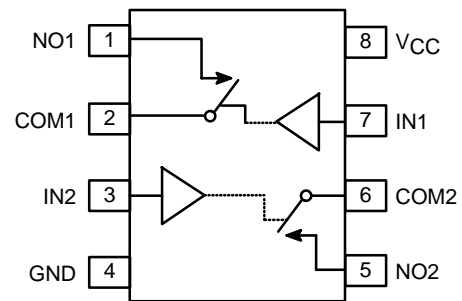
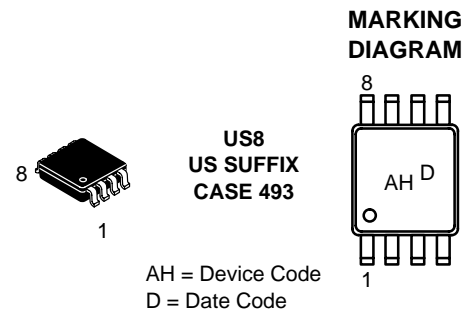

### PIN ASSIGNMENT

Pin	Function	OVT
1	NO1	Yes
2	COM1	–
3	IN2	Yes
4	GND	–
5	NO2	Yes
6	COM2	–
7	IN1	Yes
8	VCC	–

### FUNCTION TABLE

On/Off Enable Input	State of Analog Switch
L	Off
H	On

### ORDERING INFORMATION

See detailed ordering and shipping information in the package dimensions section on page 258 of this data sheet.

# NLAS2066

## MAXIMUM RATINGS

Symbol	Rating	Value	Unit
V <sub>CC</sub>	DC Supply Voltage	-0.5 to +7.0	V
V <sub>I</sub>	DC Input Voltage Pins 1, 3, 5, 7 Pins 2, 6	-0.5 to +7.0 -0.5 to V <sub>CC</sub>	V
V <sub>O</sub>	DC Output Voltage	-0.5 to +7.0	V
I <sub>IK</sub>	DC Input Diode Current V <sub>I</sub> < GND	-50	mA
I <sub>OK</sub>	DC Output Diode Current V <sub>O</sub> < GND	-50	mA
I <sub>O</sub>	DC Output Sink Current	±50	mA
I <sub>CC</sub>	DC Supply Current per Supply Pin	±100	mA
I <sub>GND</sub>	DC Ground Current per Ground Pin	±100	mA
T <sub>STG</sub>	Storage Temperature Range	-65 to +150	°C
T <sub>L</sub>	Lead Temperature, 1 mm from Case for 10 Seconds	260	°C
T <sub>J</sub>	Junction Temperature under Bias	+150	°C
θ <sub>JA</sub>	Thermal Resistance (Note 1)	250	°C/W
P <sub>D</sub>	Power Dissipation in Still Air at 85°C	250	mW
MSL	Moisture Sensitivity	Level 1	-
F <sub>R</sub>	Flammability Rating Oxygen Index: 28 to 34	UL 94 V-0 @ 0.125 in	-
V <sub>ESD</sub>	ESD Withstand Voltage Human Body Model (Note 2) Machine Model (Note 3) Charged Device Model (Note 4)	> 2000 > 200 N/A	V

Maximum ratings are those values beyond which device damage can occur. Maximum ratings applied to the device are individual stress limit values (not normal operating conditions) and are not valid simultaneously. If these limits are exceeded, device functional operation is not implied, damage may occur and reliability may be affected.

1. Measured with minimum pad spacing on an FR4 board, using 10 mm-by-1 inch, 2-ounce copper trace with no air flow
2. Tested to EIA/JESD22-A114-A
3. Tested to EIA/JESD22-A115-A
4. Tested to JESD22-C101-A

## RECOMMENDED OPERATING CONDITIONS

Symbol	Characteristics	Min	Max	Unit
V <sub>CC</sub>	Positive DC Supply Voltage	1.65	5.5	V
V <sub>IN</sub>	Digital Input Voltage (Enable)	GND	5.5	V
V <sub>IO</sub>	Static or Dynamic Voltage Across an Off Switch	GND	V <sub>CC</sub>	V
V <sub>IS</sub>	Analog Input Voltage NO COM	GND GND	V <sub>CC</sub> 5.5	V
T <sub>A</sub>	Operating Temperature Range, All Package Types	-55	+125	°C
t <sub>r</sub> , t <sub>f</sub>	Input Rise or Fall Time (Enable Input) V <sub>CC</sub> = 3.3 V ± 0.3 V V <sub>CC</sub> = 5.0 V ± 0.5 V	0 0	100 20	ns/V

**DEVICE JUNCTION TEMPERATURE VS. TIME TO 0.1% BOND FAILURES**

Junction Temperature °C	Time, Hours	Time, Years
80	1,032,200	117.8
90	419,300	47.9
100	178,700	20.4
110	79,600	9.4
120	37,000	4.2
130	17,800	2.0
140	8,900	1.0

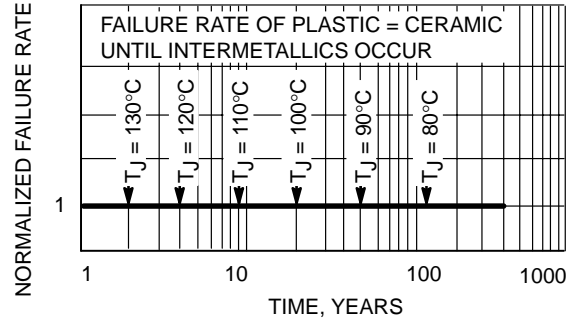

**Figure 28. Failure Rate vs. Time Junction**

**DC CHARACTERISTICS – Digital Section (Voltages Referenced to GND)**

Symbol	Parameter	Condition	V <sub>CC</sub>	Guaranteed Max Limit			Unit
				25°C	-40 to 85°C	-55 to <125°C	
V <sub>IH</sub>	Minimum High-Level Input Voltage, Enable Inputs		2.3 ± 10%	V <sub>CC</sub> × 0.55	V <sub>CC</sub> × 0.55	V <sub>CC</sub> × 0.55	V
			2.7 ± 10%	V <sub>CC</sub> × 0.55	V <sub>CC</sub> × 0.55	V <sub>CC</sub> × 0.55	
			3.0 ± 10%	V <sub>CC</sub> × 0.55	V <sub>CC</sub> × 0.55	V <sub>CC</sub> × 0.55	
			5.0 ± 10%	V <sub>CC</sub> × 0.55	V <sub>CC</sub> × 0.55	V <sub>CC</sub> × 0.55	
V <sub>IL</sub>	Maximum Low-Level Input Voltage, Enable Inputs		2.3 ± 10%	V <sub>CC</sub> × 0.30	V <sub>CC</sub> × 0.30	V <sub>CC</sub> × 0.30	V
			2.7 ± 10%	V <sub>CC</sub> × 0.30	V <sub>CC</sub> × 0.30	V <sub>CC</sub> × 0.30	
			3.0 ± 10%	V <sub>CC</sub> × 0.30	V <sub>CC</sub> × 0.30	V <sub>CC</sub> × 0.30	
			5.0 ± 10%	V <sub>CC</sub> × 0.30	V <sub>CC</sub> × 0.30	V <sub>CC</sub> × 0.30	
I <sub>IN</sub>	Maximum Input Leakage Current, Enable Inputs	V <sub>IN</sub> = 5.5 V or GND	0 V to 5.5 V	±0.1	±1.0	±1.0	µA
I <sub>CC</sub>	Maximum Quiescent Supply Current (per package)	Enable and V <sub>IS</sub> = V <sub>CC</sub> or GND	5.5	1.0	1.0	2.0	µA

# NLAS2066

## DC ELECTRICAL CHARACTERISTICS – Analog Section

Symbol	Parameter	Condition	V <sub>CC</sub>	Guaranteed Max Limit			Unit
				25°C			
R <sub>ON</sub>	Maximum On Resistance	V <sub>IN</sub> = V <sub>IH</sub> I <sub>S</sub> = 8 mA V <sub>IS</sub> = V <sub>CC</sub> to GND I <sub>S</sub> = 8 mA I <sub>S</sub> = 24 mA I <sub>S</sub> = 32 mA (Figures 29 and 30)	2.3	50	54	54	Ω
			2.7	20	24	24	
			3.0	15	19	19	
			4.5	7	11	11	
R <sub>FLAT(ON)</sub>	On Resistance Flatness	V <sub>IN</sub> = V <sub>IH</sub> I <sub>S</sub> = 8 mA V <sub>IS</sub> = 0 to V <sub>CC</sub> I <sub>S</sub> = 8 mA I <sub>S</sub> = 24 mA I <sub>S</sub> = 32 mA (Figure 32)	2.3	60	60	60	Ω
			2.7	24	24	24	
			3.0	13.5	13.5	13.5	
			4.5	3.0	3.0	3.0	
Δ R <sub>ON</sub>	On Resistance Match Between Channels	V <sub>IS</sub> = 1.4 V V <sub>IS</sub> = 1.6 V V <sub>IS</sub> = 1.8 V V <sub>IS</sub> = 2.7 V (Figures 31, 32 and 33)	2.3	1.3	1.3	1.3	Ω
			2.7	1.4	1.4	1.4	
			3.0	1.5	1.5	1.5	
			4.5	2.0	2.0	2.0	
I <sub>NO(OFF)</sub>	Off Leakage Current	V <sub>IN</sub> = V <sub>IL</sub> V <sub>NO</sub> = 1.0 V, V <sub>COM</sub> = 4.5 V or V <sub>COM</sub> = 1.0 V and V <sub>NO</sub> 4.5 V	5.5	1.0	10	100	nA
I <sub>COM(OFF)</sub>	Off Leakage Current	V <sub>IN</sub> = V <sub>IL</sub> V <sub>NO</sub> = 4.5 V or 1.0 V V <sub>COM</sub> = 1.0 V or 4.5 V	5.5	1.0	10	100	nA

## AC ELECTRICAL CHARACTERISTICS (Input t<sub>r</sub> = t<sub>f</sub> = 3.0 ns)

Symbol	Parameter	Condition	V <sub>CC</sub> (V)	Guaranteed Max Limit									Unit
				25°C			-40 to 85°C			-55 to <125°C			
				Min	Typ	Max	Min	Typ	Max	Min	Typ	Max	
t <sub>ON</sub>	Turn-On Time	R <sub>L</sub> = 300 Ω, C <sub>L</sub> = 35 pF (Figures 34, 41 and 42)	2.3		8	9			10			10	ns
			2.7		4	5			7			7	
			3.0		3	4			6			6	
			4.5		2	3			5			5	
t <sub>OFF</sub>	Turn-Off Time	R <sub>L</sub> = 300 Ω, C <sub>L</sub> = 35 pF (Figures 34, 41 and 42)	2.3		8	10			11			11	ns
			2.7		6	8			9			9	
			3.0		5	7			8			8	
			4.5		4	6			7			7	

		Typical @ 25°C, V <sub>CC</sub> = 5.0 V	Unit
C <sub>IN</sub>	Maximum Input Capacitance, Select Input	3.0	pF
C <sub>NO</sub> or C <sub>NC</sub>	Analog I/O (Switch Off)	10	
C <sub>COM(OFF)</sub>	Common I/O (Switch Off)	10	
C <sub>COM(ON)</sub>	Feedthrough (Switch Off)	10	

## NLA2066

### ADDITIONAL APPLICATIONS CHARACTERISTICS (Voltage Reference to GND Unless Noted)

Symbol	Parameter	Condition	V <sub>CC</sub> (V)	Typical 25°C	Unit
BW	Maximum On-Channel -3.0 dB Bandwidth or Minimum Frequency Response	V <sub>IS</sub> = 0 dBm (Figure 35 and 36)	2.3	102	MHz
			2.7	175	
			3.0	180	
			4.5	186	
V <sub>ONL</sub>	Maximum Feed-Through On Loss	V <sub>IS</sub> = 0 dBm @ 10 kHz (Figure 35 and 36)	2.3	-2.2	dB
			2.7	-0.9	
			3.0	-0.8	
			4.5	-0.4	
V <sub>ISO</sub>	Off-Channel Isolation	f = 100 kHz V <sub>IS</sub> = 1.0 V RMS (Figure 37 and 38)	2.3	-73	dB
			2.7	-74	
			3.0	-74	
			4.5	-75	
Q	Charge Injection Enable Input to Common I/O	V <sub>IS</sub> = V <sub>CC</sub> to GND, F <sub>IS</sub> = 20 kHz (Figure 39)	3.0	4.8	pC
			5.5	7.4	
THD	Total Harmonic Distortion TDH + Noise	F <sub>IS</sub> = 10 Hz to 100 kHz, R <sub>L</sub> = R <sub>gen</sub> = 600 Ω, C <sub>L</sub> = 50 pF (Figure 40)	3.0	0.19	%
			5.5	0.06	

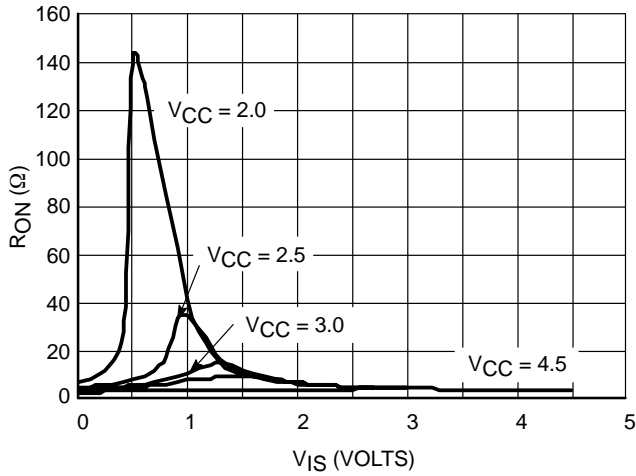

Figure 29. RON vs. VCOM and VCC (@25°C)

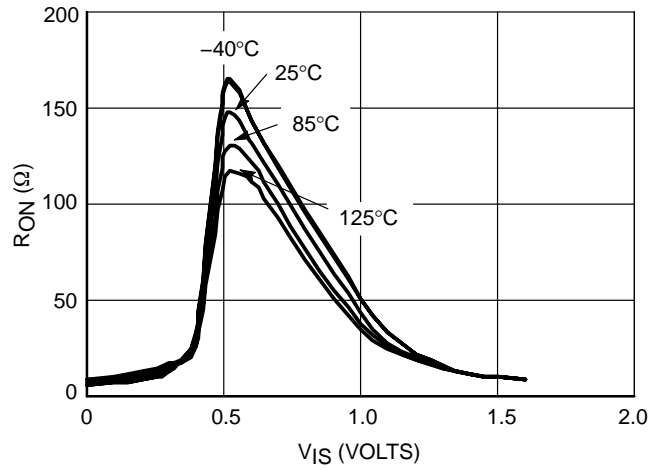

Figure 30. RON vs. VCOM and Temperature, VCC = 2.0 V

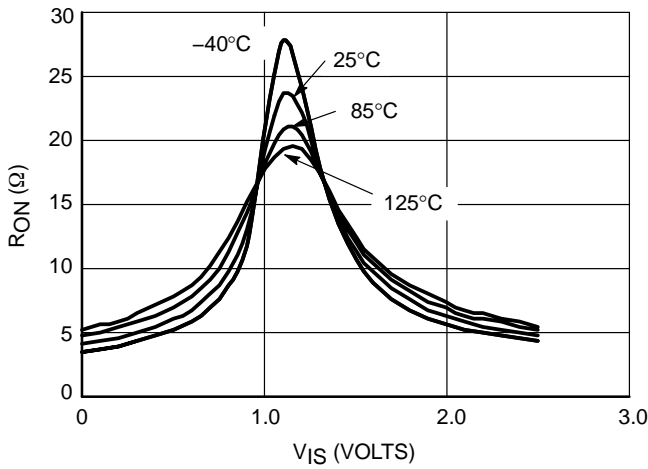

Figure 31. RON vs. VCOM and Temperature, VCC = 2.5 V

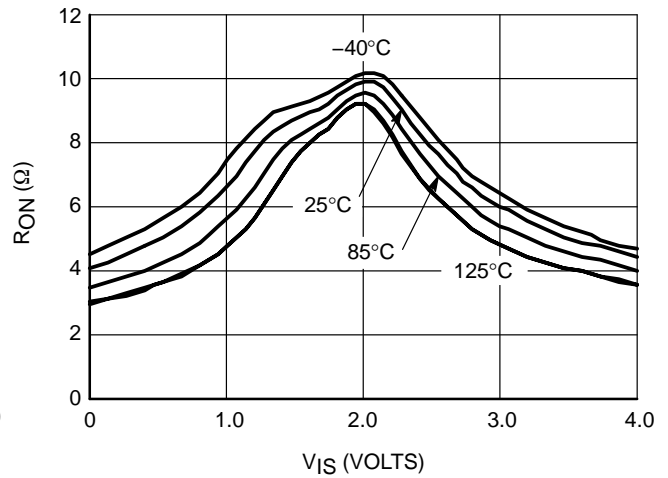

Figure 32. RON vs. VCOM and Temperature, VCC = 3.0 V

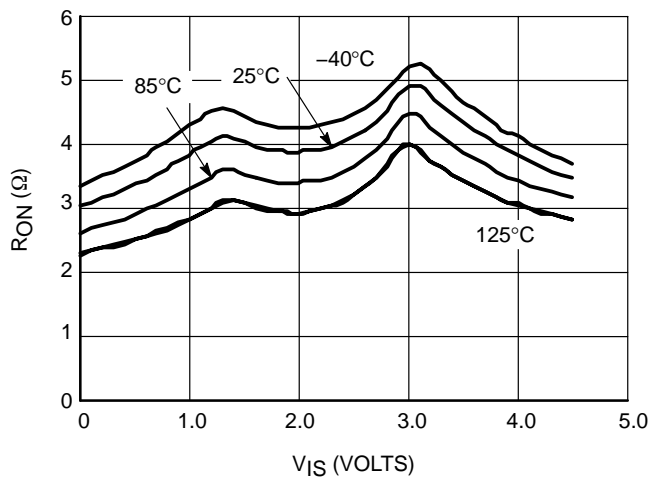

Figure 33. RON vs. VCOM and Temperature, VCC = 4.5 V

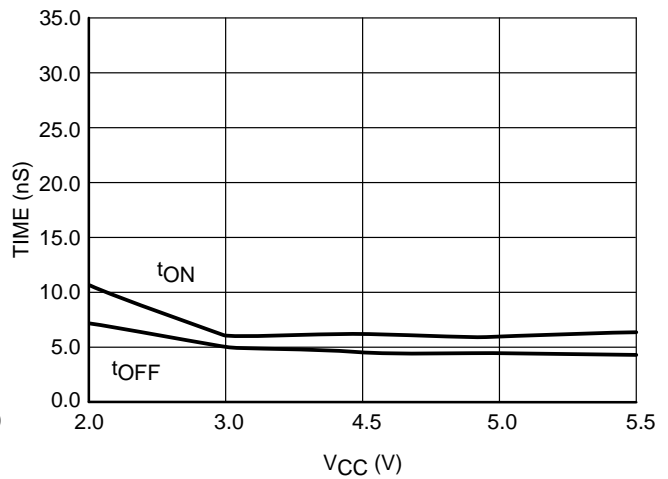

Figure 34. Switching Time vs. Supply Voltage, T = 25°C

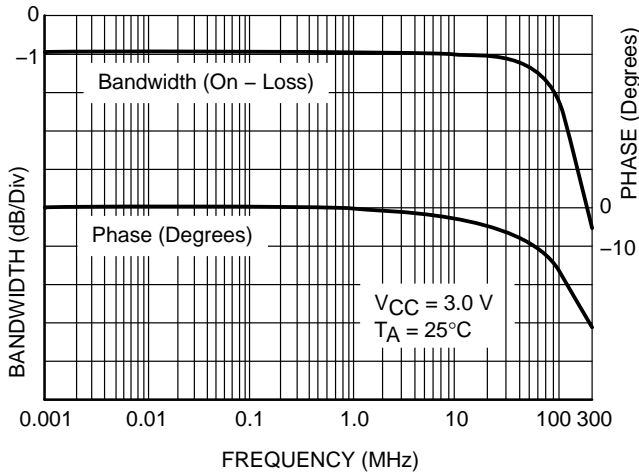

Figure 35. ON Channel Bandwidth and Phase Shift Over Frequency

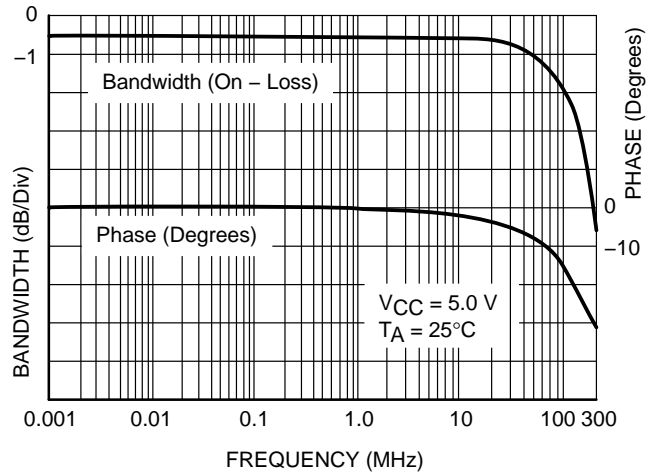

Figure 36. ON Channel Bandwidth and Phase Shift Over Frequency

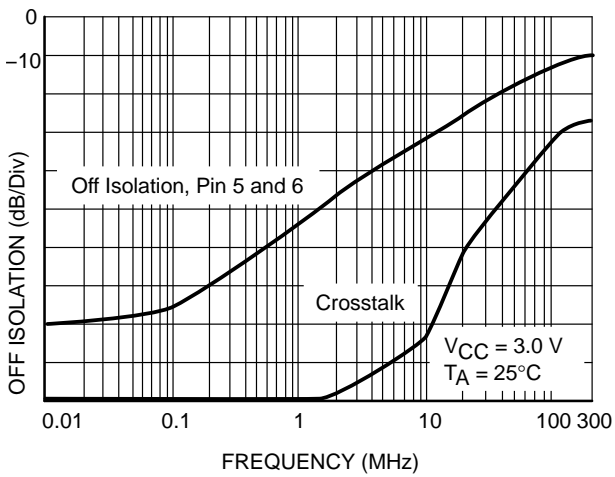

Figure 37. Off Isolation and Crosstalk

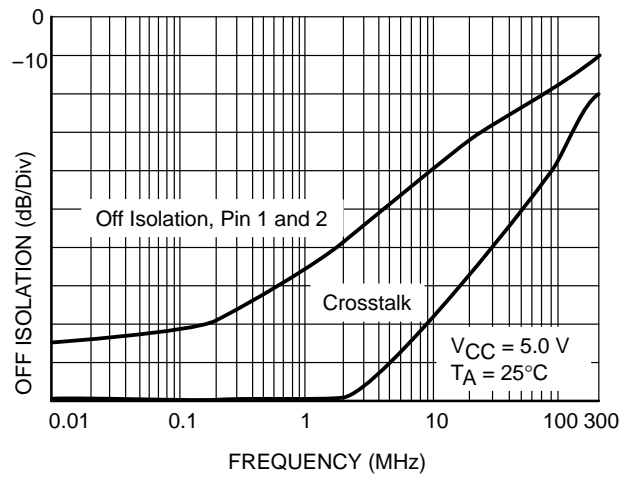

Figure 38. Off Isolation and Crosstalk

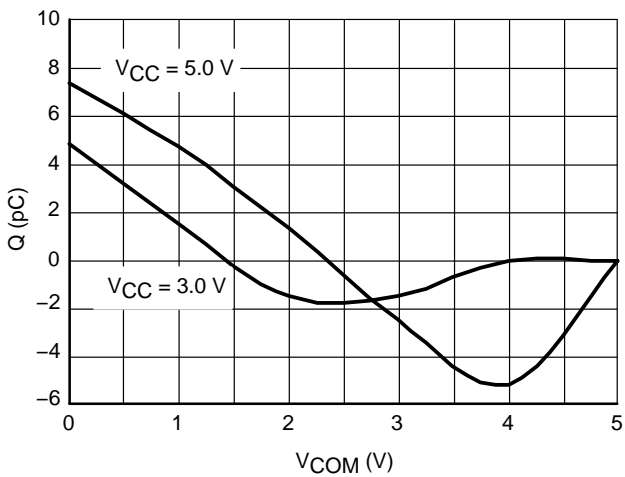

Figure 39. Charge Injection vs. VCOM

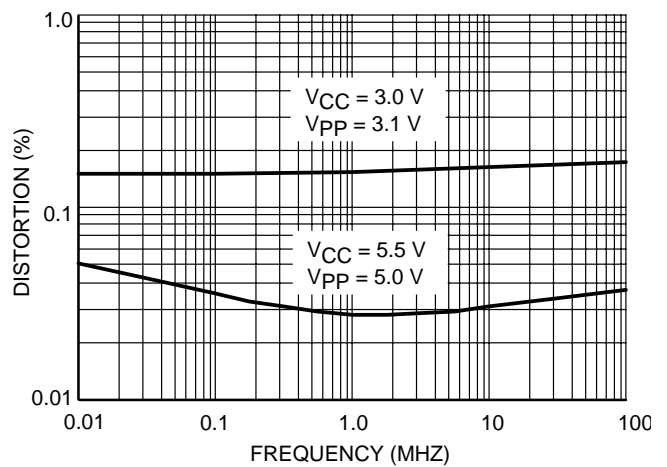

Figure 40. THD vs. Frequency

TIMING INFORMATION

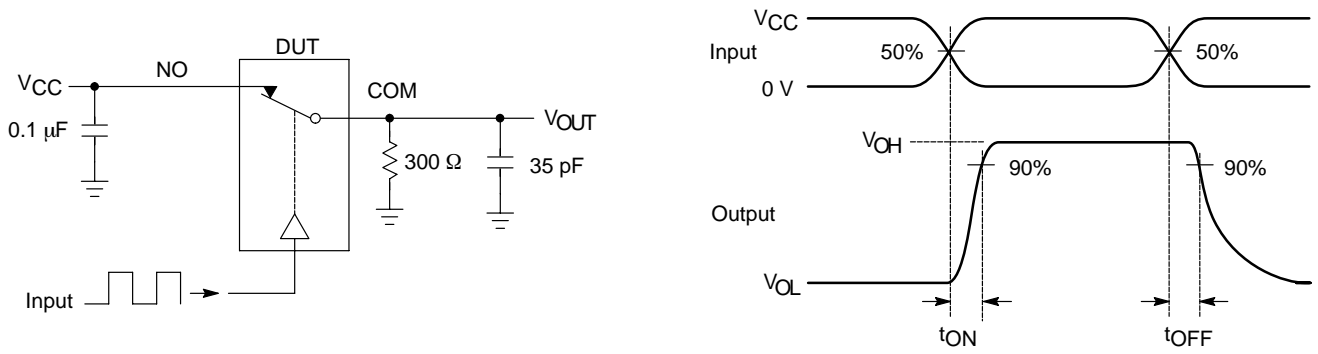

Figure 41.  $t_{ON}/t_{OFF}$

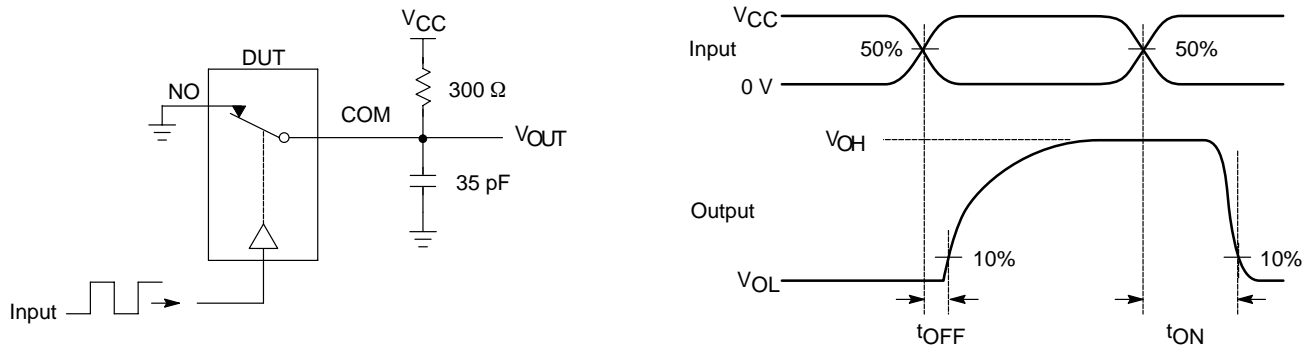

Figure 42.  $t_{ON}/t_{OFF}$

VCC	VMI
2.0 V	1.0 V
3.0 V	1.5 V
4.5 V	1.5 V



# NLAS2066

## DEVICE ORDERING INFORMATION

Device	Device Nomenclature				Package Type	Shipping†
	Circuit Indicator	Technology	Device Function	Package Suffix		
NLAS2066US	NL	AS	2066	US	US8	3,000 / Tape & Reel
NLAS2066USG	NL	AS	2066	US	US8 (Pb-Free)	3,000 / Tape & Reel
NLAS2066UST3	NL	AS	2066	UST3	US8	10,000 / Tape & Reel
NLAS2066UST3G	NL	AS	2066	UST3	US8 (Pb-Free)	10,000 / Tape & Reel

†For information on tape and reel specifications, including part orientation and tape sizes, please refer to our Tape and Reel Packaging Specifications Brochure, BRD8011/D.