

CAT5136, CAT5137, CAT5138

Digital Potentiometers (POTs) with 128 Taps and I²C Interface

Description

CAT5136, CAT5137, and CAT5138 are a family of digital POTs operating like mechanical potentiometers in various configurations. The tap points between the 127 equal resistive elements are connected to the wiper output via CMOS switches. The switches are controlled by a 7-bit Wiper Control Register (WCR) via the I²C serial bus. CAT5136 is configured as a variable resistor. CAT5137 and CAT5138 are resistive voltage dividers, with one terminal of the potentiometer connected to GND. CAT5137 and CAT5138 have different device IDs, which makes it possible to use both on the same I²C bus. Upon power-up, the WCR is set to mid-scale (1000000).

Features

- Single Linear Digital Potentiometer with 128 Taps
- End-to-End Resistance of 10 k Ω , 50 k Ω and 100 k Ω
- I²C Interface
- Wiper goes to Midscale at Power-up
- Digital Supply Range (V_{DD}): 2.7 V to 5.5 V
- Low Standby Current
- Industrial Temperature Range: -40°C to +85°C
- 6-pin SC-70 Package
- These Devices are Pb-Free, Halogen Free/BFR Free and are RoHS Compliant

Typical Applications

- LCD Screen Adjustment
- Volume Control
- Mechanical Potentiometer Replacement
- Gain Adjustment
- Line Impedance Matching
- VCOM Setting Adjustments



ON Semiconductor®

<http://onsemi.com>



SC-70
SD SUFFIX
CASE 419AD

PIN CONNECTIONS

(for low pin count devices)

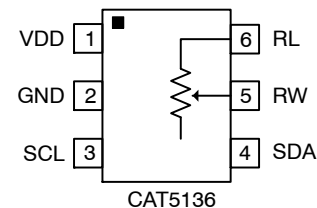

CAT5136

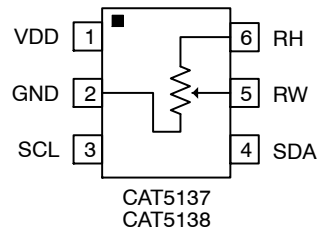

CAT5137
CAT5138

(Top Views)

See detailed pin function descriptions on page 2.

ORDERING INFORMATION

See detailed ordering and shipping information in the package dimensions section on page 9 of this data sheet.

CAT5136, CAT5137, CAT5138

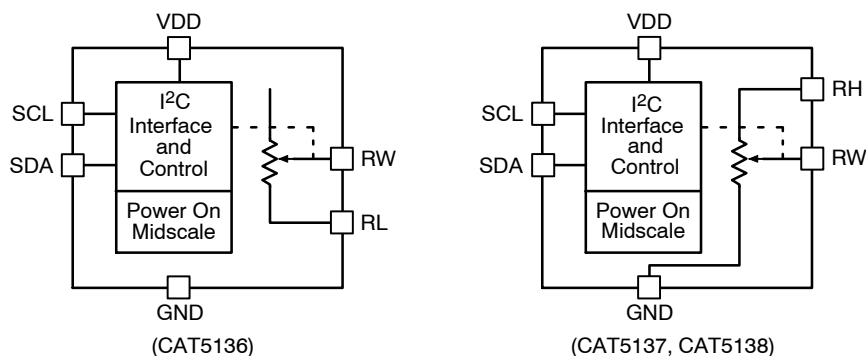

Figure 1. Block Diagram

Table 1. PIN FUNCTION DESCRIPTION

Pin No.		Pin Name	Description
CAT5136	CAT5137/CAT5138		
1	1	VDD	Digital Supply Voltage (2.7 V to 5.5 V)
2	2	GND	Ground
3	3	SCL	Serial Bus Clock input for the I ² C Serial Bus. This clock is used to clock all data transfers into and out of the CAT5136-8
4	4	SDA	Serial Data Input/Output – Bidirectional Serial Data pin used to transfer data into and out of the CAT5136-8. This is an Open-Drain I/O and can be wire OR'd with other Open-Drain (or Open Collector) I/Os.
5	5	RW	Wiper Terminal for the potentiometer
6	–	RL	Low Reference Terminal for the potentiometer
–	6	RH	High Reference Terminal for the potentiometer

Table 2. ABSOLUTE MAXIMUM RATINGS

Parameter	Symbol	Range	Unit
Temperature Under Bias		–55 to +125	°C
Storage Temperature Range	T _{STG}	–65 to 150	°C
Voltage on any SDA, SCL, A0 & A1 pins with respect to Ground (Note 1)		–0.3 to V _{DD} + 0.3	V
Voltage on RH, RL & RW pins with respect to Ground		–0.3 to V _{DD} + 0.3	V
V _{DD} with respect to Ground		–0.3 to +6	V
Wiper Current (10 sec)		±6	mA
Lead Soldering temperature (10 sec)		+300	°C

Stresses exceeding Maximum Ratings may damage the device. Maximum Ratings are stress ratings only. Functional operation above the Recommended Operating Conditions is not implied. Extended exposure to stresses above the Recommended Operating Conditions may affect device reliability.

1. Latch-up protection is provided for stresses up to 100 mA on address and data pins from –0.3 V to V_{DD} +0.3 V.

Table 3. RECOMMENDED OPERATION CONDITIONS

Parameter	Symbol	Value	Unit
Digital Supply Voltage	V _{DD}	+2.7 to +5.5	V
Operating Temperature Range		–40 to +85	°C

CAT5136, CAT5137, CAT5138

Table 4. POTENTIOMETERS CHARACTERISTICS (Over recommended operating conditions unless otherwise stated.)

Parameter	Symbol	Test Conditions	Limits			Units
			Min	Typ	Max	
Potentiometer Resistance (10 kΩ)	R _{POT}			10		kΩ
Potentiometer Resistance (50 kΩ)	R _{POT}			50		kΩ
Potentiometer Resistance (100 kΩ)	R _{POT}			100		kΩ
Potentiometer Resistance Tolerance	R _{TOL}				±20	%
Power Rating		25°C			50	mW
Wiper Current	I _W				±3	mA
Wiper Resistance	R _W	V _{DD} = 3.3 V		85	200	Ω
Voltage on R _W , R _H or R _L	V _{TERM}	GND = 0 V; V _{DD} = 2.7 V to +5.5 V	GND		V _{DD}	V
Resolution	RES			0.78		%
Integral Non-Linearity (Note 3)	INL	V _{W(n)(actual)} - V _{W(n)(expected)} (Notes 6, 7)			±1	LSB (Note 5)
Differential Non-Linearity (Note 4)	DNL	V _{W(n+1)} - [V _{W(n)} +LSB] (Notes 6, 7)			1	LSB (Note 5)
Resistor Integral Non-Linearity	R _{INL}	R _n - n*LSB (Notes 6, 8)			± 2	LSB (Note 5)
Resistor Differential Non-Linearity	R _{DNL}	R _n - [R _{n-1} + LSB] (Notes 6, 8)			± 1	LSB (Note 5)
Temperature Coefficient of R _{POT}	T _{CRPOT}	(Note 2)		±300		ppm/°C
Ratiometric Temperature Coefficient	T _{CRatio}	(Note 2)			30	ppm/°C
Potentiometer Capacitances	C _H /C _L /C _W	(Note 2)		10/10/25		pF
Frequency Response	fc	R _{POT}		0.4		MHz

2. This parameter is tested initially and after a design or process change that affects the parameter.
3. Integral Non-Linearity is utilized to determine actual wiper voltage versus expected voltage as determined by wiper position when used as a potentiometer.
4. Differential Non-Linearity is utilized to determine the actual change in voltage between two successive tap positions when used as a potentiometer.
5. LSB = (R_{HM} - R_{LM})/127; where R_{HM} and R_{LM} are the highest and lowest measured values on the wiper terminal.
6. n = 1, 2, ..., 127
7. V_{DD} @ R_H; V_W measured @ R_W with no load.
8. R_W and R_L in the range of 0 V and V_{DD}.

Table 5. D.C. ELECTRICAL CHARACTERISTICS (Over recommended operating conditions unless otherwise stated.)

Parameter	Symbol	Test Conditions	Min	Max	Units
Power Supply Current (Write/Read)	I _{DD}	F _{SCL} = 400 kHz, SDA Open, V _{DD} = 5.5 V, Input = GND		200	μA
Standby Current	I _{SB(VDD)}	V _{IN} = GND or V _{DD} , SDA = V _{DD}		0.5	μA
Input Leakage Current	I _{LI}	V _{IN} = GND to V _{DD}	-1	1	μA
Output Leakage Current	I _{LO}	V _{OUT} = GND to V _{DD}	-1	1	μA
Input Low Voltage	V _{IL}		-0.3	V _{DD} × 0.3	V
Input High Voltage	V _{IH}		V _{DD} × 0.7	V _{DD} + 0.3	V
Output Low Voltage (V _{DD} = 3.0 V)	V _{OL}	I _{OL} = 3 mA		0.4	V

CAT5136, CAT5137, CAT5138

Table 6. A.C. CHARACTERISTICS

Parameter (see Figure 6)	Symbol	Min	Typ	Max	Units
Clock Frequency	F_{SCL}			400	kHz
Noise Suppression Time Constant at SCL & SDA Inputs	T_I (Note 9)			50	ns
SCL Low to SDA Data Out and ACK Out	t_{AA}			1	μs
Time the bus must be free before a new transmission can start	t_{BUF} (Note 9)	1.2			μs
Start Condition Hold Time	$t_{HD:STA}$	0.6			μs
Clock Low Period	t_{LOW}	1.2			μs
Clock High Period	t_{HIGH}	0.6			μs
Start Condition Setup Time (for a Repeated Start Condition)	$t_{SU:STA}$	0.6			μs
Data In Setup Time	$t_{SU:DAT}$	100			ns
Data in Hold Time	$t_{HD:DAT}$	0			μs
SDA and SCL Rise Time	t_R (Note 9)			0.3	μs
SDA and SCL Fall Time	t_F (Note 9)			300	ns
Stop Conditions Setup Time	$t_{SU:STO}$	0.6			μs
Data Out Hold Time	t_{DH}	100			ns

9. This parameter is tested initially and after a design or process change that affects the parameter.

Table 7. CAPACITANCE ($T_A = 25^\circ C$, $f = 1.0$ MHz, $V_{DD} = 5.0$ V)

Parameter	Symbol	Test Conditions	Min	Typ	Max	Unit
Input/Output Capacitance (SDA, SDC)	$C_{I/O}$	$V_{I/O} = 0$ V (Note 10)			10	pF

10. This parameter is tested initially and after a design or process change that affects the parameter.

Table 8. POWER-UP TIMING (Notes 11, 12)

Symbol	Parameter	Min	Max	Units
t_{PUR}	Power-up to Read Operation		1	ms
t_{PUW}	Power-up to Write Operation		1	ms

11. This parameter is tested initially and after a design or process change that affects the parameter.

12. t_{PUR} and t_{PUW} are the delays required from the time V_{DD} is stable until the specified operation can be initiated.

Table 9. WIPER TIMING

Symbol	Parameter	Min	Max	Units
t_{WRPO}	Wiper Response Time After Power Supply Stable	5	10	μs
t_{WRL}	Wiper Response Time After Instruction Issued	5	10	μs

TYPICAL PERFORMANCE CHARACTERISTICS

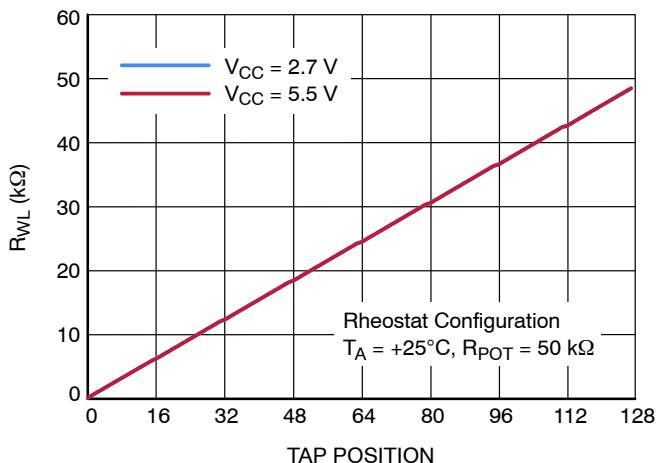

Figure 2. Resistance between R_W and R_L

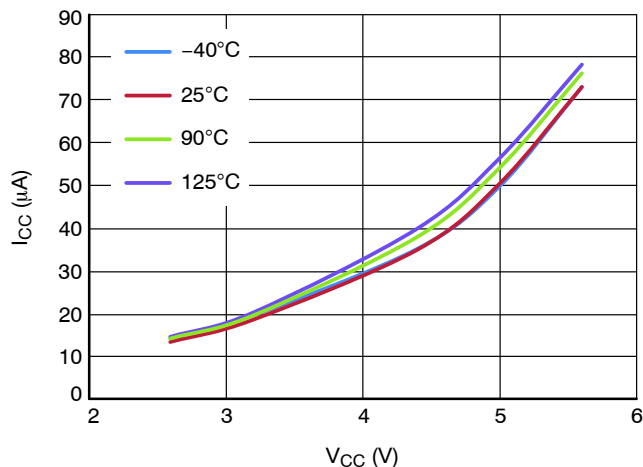

Figure 3. Power Supply Current

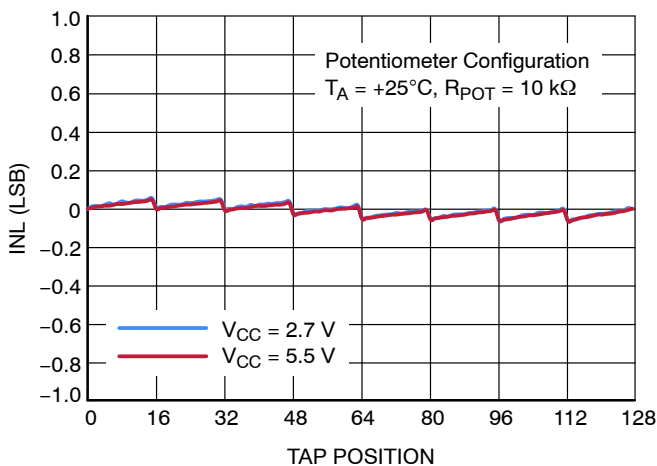

Figure 4. Integral Non-Linearity

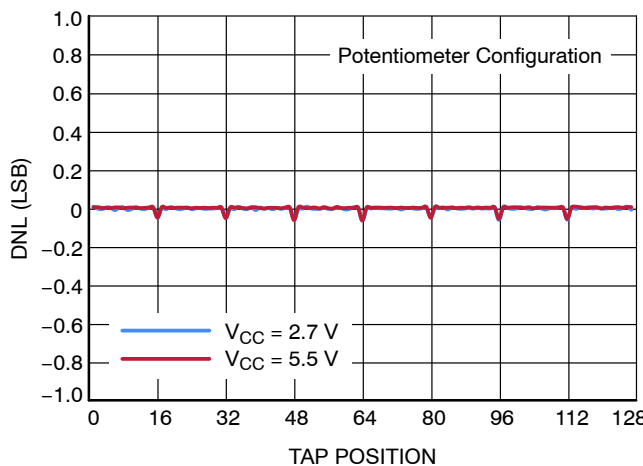

Figure 5. Differential Non-Linearity

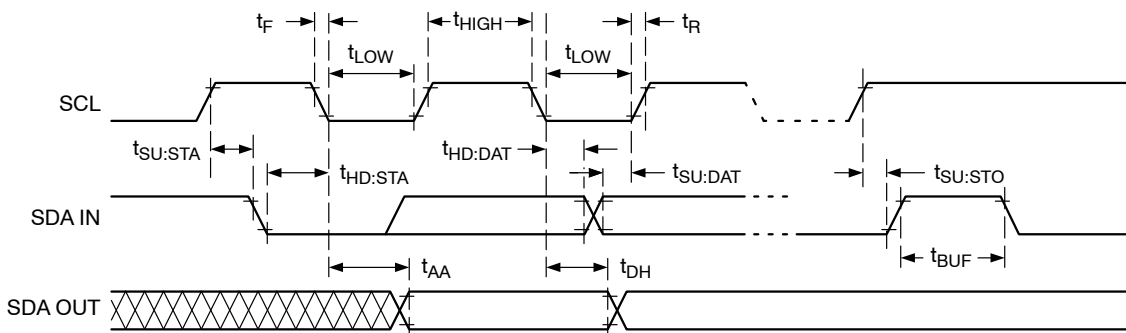

Figure 6. Bus Timing

CAT5136, CAT5137, CAT5138

SERIAL BUS PROTOCOL

The following defines the features of the I²C bus protocol:

1. Data transfer may be initiated only when the bus is not busy.
2. During a data transfer, the data line must remain stable whenever the clock line is high. Any changes in the data line while the clock is high will be interpreted as a START or STOP condition.

The device controlling the transfer is a master, typically a processor or controller, and the device being controlled is the slave. The master will always initiate data transfers and provide the clock for both transmit and receive operations. Therefore, the CAT513x will be considered a slave device in all applications.

START Condition

The START Condition precedes all commands to the device, and is defined as a HIGH to LOW transition of SDA when SCL is HIGH. The CAT513x monitors the SDA and SCL lines and will not respond until this condition is met (see Figure 7).

STOP Condition

A LOW to HIGH transition of SDA when SCL is HIGH determines the STOP condition. All operations must end with a STOP condition (see Figure 7).

Acknowledge

After a successful data transfer, each receiving device is required to generate an acknowledge. The acknowledging device pulls down the SDA line during the ninth clock cycle, signaling that it received the 8 bits of data (see Figure 8).

The CAT513x responds with an acknowledge after receiving a START condition and its slave address. If the device has been selected along with a write operation, it responds with an acknowledge after receiving each 8-bit byte.

When the CAT513x is in a READ mode it transmits 8 bits of data, releases the SDA line, and monitors the line for an acknowledge. Once it receives this acknowledge, the CAT513x will continue to transmit data. If no acknowledge is sent by the Master, the device terminates data transmission and waits for a STOP condition.

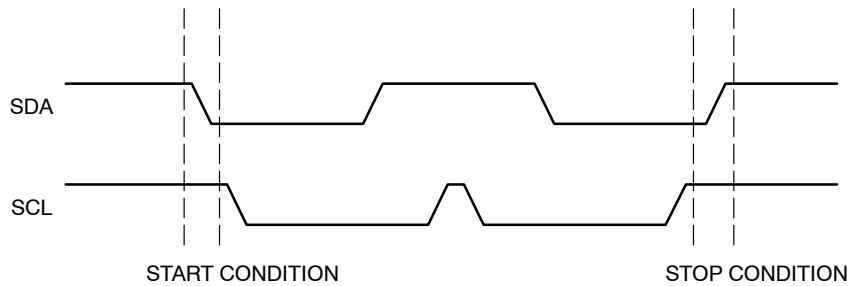

Figure 7. Start/Stop Condition

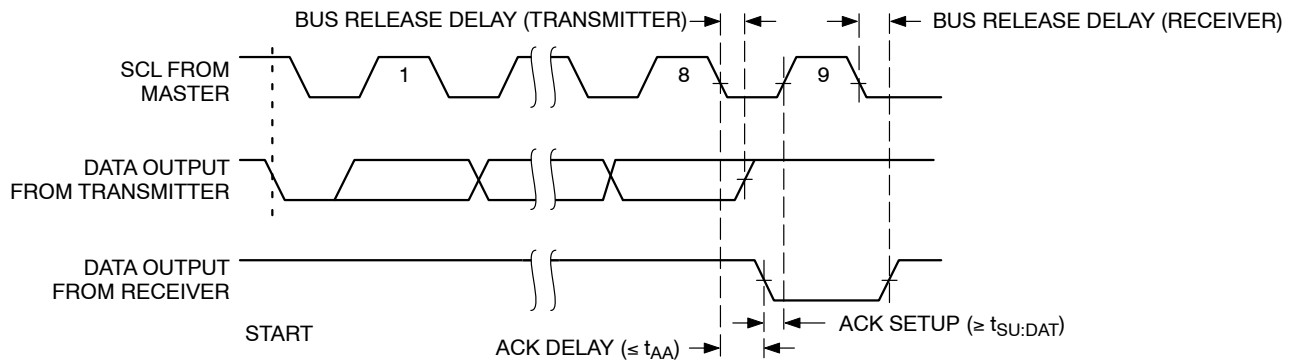

Figure 8. Acknowledge Condition

CAT5136, CAT5137, CAT5138

DEVICE DESCRIPTION

Slave Address Instruction Byte Description

The first byte sent to the CAT513x from the master processor is called the Slave Address Byte. The most significant seven bits of the slave address are a device type identifier. For CAT5136 and CAT5137 these bits are fixed at 0101110. For CAT5138, they are 0111110. This allows both CAT5137 and CAT5138, which are functionally identical, to reside on the same bus (refer to Table 10).

Only the device with slave address matching the input byte will be accessed by the master.

The last bit is the READ/WRITE bit and determines the function to be performed. If it is a “1” a read command is initiated and if it is a “0” a write is initiated.

After the Master sends a START condition and the slave address byte, the CAT513x monitors the bus and responds with an acknowledge when its address matches the transmitted slave address.

Table 10. BYTE 1 SLAVE ADDRESS AND INSTRUCTION BYTE

Device	Device Type Identifier							Read/Write
	ID6	ID5	ID4	ID3	ID2	ID1	ID0	
CAT5136	0	1	0	1	1	1	0	R/W
CAT5137	0	1	0	1	1	1	0	R/W
CAT5138	0	1	1	1	1	1	0	R/W

(MSB) (LSB)

Wiper Control Register (WCR) Description

The CAT513x contains a 7-bit volatile Wiper Control Register which is decoded to select one of the 128 switches along its resistor array. The Wiper Control Register loses its contents when the CAT513x is powered-down. At power-up, the register is loaded with the midscale value 40h. The contents of the WCR may be read or changed directly by the host using a READ/WRITE command on the I²C bus (see Table 1 to access WCR). Since the CAT513x will only make use of the 7 LSB bits, the first data bit, or MSB, is ignored on write instructions and will always come back as a “0” on read commands.

A write operation (see Table 11) requires a Start condition, followed by a valid slave address byte, a valid address byte 00h, a data byte and a STOP condition. After each of the three bytes, the CAT513x responds with an acknowledge. After the third byte, the data is written to the Wiper Control Register, and the wiper changes position accordingly.

A read operation (see Table 12) requires a Start condition, followed by a valid slave address byte for write, a valid address byte 00h, a second START and a second slave address byte for read. After each of the three bytes, the CAT513x responds with an acknowledge and then the device transmits the data byte. The master terminates the read operation by issuing a STOP condition following the last bit of Data byte.

Table 11. WRITE OPERATION

CAT5136 and CAT5137

START	1st byte							ACK	2nd byte							ACK	3rd byte								ACK	STOP		
	SLAVE ADDRESS								Wb	ADDRESS BYTE							DATA BYTE IN											
S	0	1	0	1	1	1	0	0	A	0	0	0	0	0	0	0	0	A	X	D6	D5	D4	D3	D2	D1	D0	A	P

CAT5138

START	1st byte							ACK	2nd byte							ACK	3rd byte								ACK	STOP	
	SLAVE ADDRESS								Wb	ADDRESS BYTE							DATA BYTE IN										
S	0	1	1	1	1	1	0	0	A	0	0	0	0	0	0	0	A	X	D6	D5	D4	D3	D2	D1	D0	A	P

CAT5136, CAT5137, CAT5138

Table 12. READ OPERATION

CAT5136 and CAT5137																																						
START	1st byte							ACK	2nd byte							ACK	START	3rd byte							ACK	4th byte							NoACK	STOP				
	SLAVE ADDRESS								Wb	ADDRESS BYTE								SLAVE ADDRESS								OUTPUT DATA BYTE												
S	0	1	0	1	1	0	0	A		0	0	0	0	0	0	0	0	0	A	S	0	1	0	1	1	1	0	1	A	0	D6	D5	D4	D3	D2	D1	D0	NA
CAT5138																																						
START	1st byte							ACK	2nd byte							ACK	START	3rd byte							ACK	4th byte							NoACK	STOP				
	SLAVE ADDRESS								Wb	ADDRESS BYTE								SLAVE ADDRESS								OUTPUT DATA BYTE												
S	0	1	1	1	1	0	0	A		0	0	0	0	0	0	0	0	0	A	S	0	1	1	1	1	1	0	1	A	0	D6	D5	D4	D3	D2	D1	D0	NA

POTENTIOMETER OPERATION

CAT5136, CAT5137, CAT5138 are a family of a 128-position, digital controlled potentiometers. When V_{DD} is applied, the device automatically turns on at the mid-point wiper location (64).

At power-down, it is recommended to turn-off first the signals on RH, RW and RL, followed by V_{DD} , in order to avoid unexpected transitions of the wiper and uncontrolled current overload of the potentiometer.

The end-to-end nominal resistance of the potentiometer has 128 contact points linearly distributed across the total resistor. Each of these contact points is addressed by the 7 bit

wiper register which is decoded to select one of these 128 contact points.

Each contact point generates a linear resistive value between the 0 position and the 127 position. These values can be determined by dividing the end-to-end value of the potentiometer by 127. In the case of the 50 k Ω potentiometer $\sim 390 \Omega$ is the resistance between each wiper position. However in addition to the $\sim 390 \Omega$ for each resistive segment of the potentiometer, a wiper resistance offset must be considered. Table 13 shows the effect of this value and how it would appear on the wiper terminal.

Table 13. POTENTIOMETER RESISTANCE AND WIPER RESISTANCE OFFSET EFFECTS

Position	Typical RW to RL Resistance for 50 k Ω Digital Potentiometer
00	70 Ω or 0 Ω + 70 Ω
01	460 Ω or 390 Ω + 70 Ω
63	24,870 Ω or 24,800 Ω + 70 Ω
127	50,070 Ω or 50,000 Ω + 70 Ω

CAT5136, CAT5137, CAT5138

Table 14. ORDERING INFORMATION

Device Order Number	Specific Device Marking	Package Type	Temperature Range	Resistance (kΩ)	Lead Finish	Shipping†
CAT5136SDI-50GT3	P64	SC-70-6	I = Industrial (-40°C to +85°C)	50	NiPdAu	3,000 / Tape & Reel
CAT5137SDI-10GT3 (Note 14)	P72	SC-70-6	I = Industrial (-40°C to +85°C)	10	NiPdAu	3,000 / Tape & Reel
CAT5137SDI-00GT3	P75	SC-70-6	I = Industrial (-40°C to +85°C)	100	NiPdAu	3,000 / Tape & Reel
CAT5138SDI-10GT3	P82	SC-70-6	I = Industrial (-40°C to +85°C)	10	NiPdAu	3,000 / Tape & Reel

†For information on tape and reel specifications, including part orientation and tape sizes, please refer to our Tape and Reel Packaging Specifications Brochure, BRD8011/D.

13. For detailed information and a breakdown of device nomenclature and numbering systems, please see the ON Semiconductor Device Nomenclature document, TND310/D, available at www.onsemi.com

14. Contact factory for availability.

MECHANICAL CASE OUTLINE

PACKAGE DIMENSIONS

ON Semiconductor®



SC-88 (SC-70 6 Lead), 1.25x2
CASE 419AD-01
ISSUE A

DATE 07 JUL 2010

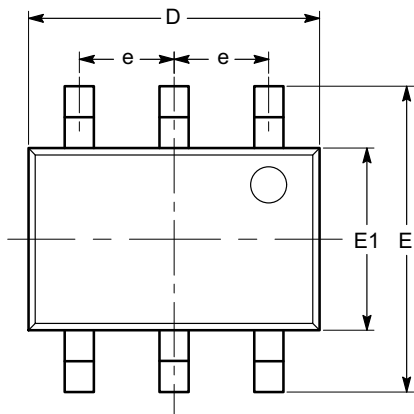

TOP VIEW

SYMBOL	MIN	NOM	MAX
A	0.80		1.10
A1	0.00		0.10
A2	0.80		1.00
b	0.15		0.30
c	0.10		0.18
D	1.80	2.00	2.20
E	1.80	2.10	2.40
E1	1.15	1.25	1.35
e	0.65 BSC		
L	0.26	0.36	0.46
L1	0.42 REF		
L2	0.15 BSC		
θ	0°		8°
θ_1	4°		10°

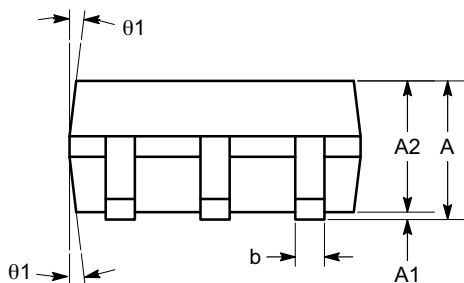

SIDE VIEW

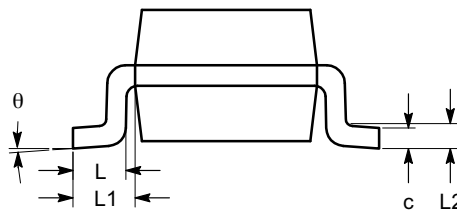

END VIEW

Notes:

- (1) All dimensions are in millimeters. Angles in degrees.
- (2) Complies with JEDEC MO-203.

DOCUMENT NUMBER:	98AON34266E	Electronic versions are uncontrolled except when accessed directly from the Document Repository. Printed versions are uncontrolled except when stamped "CONTROLLED COPY" in red.
DESCRIPTION:	SC-88 (SC-70 6 LEAD), 1.25X2	PAGE 1 OF 1

ON Semiconductor and are trademarks of Semiconductor Components Industries, LLC dba ON Semiconductor or its subsidiaries in the United States and/or other countries. ON Semiconductor reserves the right to make changes without further notice to any products herein. ON Semiconductor makes no warranty, representation or guarantee regarding the suitability of its products for any particular purpose, nor does ON Semiconductor assume any liability arising out of the application or use of any product or circuit, and specifically disclaims any and all liability, including without limitation special, consequential or incidental damages. ON Semiconductor does not convey any license under its patent rights nor the rights of others.

onsemi, **Onsemi**, and other names, marks, and brands are registered and/or common law trademarks of Semiconductor Components Industries, LLC dba "**onsemi**" or its affiliates and/or subsidiaries in the United States and/or other countries. **onsemi** owns the rights to a number of patents, trademarks, copyrights, trade secrets, and other intellectual property. A listing of **onsemi**'s product/patent coverage may be accessed at www.onsemi.com/site/pdf/Patent-Marking.pdf. **onsemi** reserves the right to make changes at any time to any products or information herein, without notice. The information herein is provided "as-is" and **onsemi** makes no warranty, representation or guarantee regarding the accuracy of the information, product features, availability, functionality, or suitability of its products for any particular purpose, nor does **onsemi** assume any liability arising out of the application or use of any product or circuit, and specifically disclaims any and all liability, including without limitation special, consequential or incidental damages. Buyer is responsible for its products and applications using **onsemi** products, including compliance with all laws, regulations and safety requirements or standards, regardless of any support or applications information provided by **onsemi**. "Typical" parameters which may be provided in **onsemi** data sheets and/or specifications can and do vary in different applications and actual performance may vary over time. All operating parameters, including "Typicals" must be validated for each customer application by customer's technical experts. **onsemi** does not convey any license under any of its intellectual property rights nor the rights of others. **onsemi** products are not designed, intended, or authorized for use as a critical component in life support systems or any FDA Class 3 medical devices or medical devices with a same or similar classification in a foreign jurisdiction or any devices intended for implantation in the human body. Should Buyer purchase or use **onsemi** products for any such unintended or unauthorized application, Buyer shall indemnify and hold **onsemi** and its officers, employees, subsidiaries, affiliates, and distributors harmless against all claims, costs, damages, and expenses, and reasonable attorney fees arising out of, directly or indirectly, any claim of personal injury or death associated with such unintended or unauthorized use, even if such claim alleges that **onsemi** was negligent regarding the design or manufacture of the part. **onsemi** is an Equal Opportunity/Affirmative Action Employer. This literature is subject to all applicable copyright laws and is not for resale in any manner.

PUBLICATION ORDERING INFORMATION

LITERATURE FULFILLMENT:

Email Requests to: orderlit@onsemi.com

onsemi Website: www.onsemi.com

TECHNICAL SUPPORT

North American Technical Support:
Voice Mail: 1 800-282-9855 Toll Free USA/Canada
Phone: 011 421 33 790 2910

Europe, Middle East and Africa Technical Support:

Phone: 00421 33 790 2910

For additional information, please contact your local Sales Representative