

NCN2612

6-Differential Channel 1:2 Switch for PCIe 2.0 and Display Port 1.1

The NCN2612 is a 6-Channel differential SPDT switch designed to route PCI Express Gen2 and/or DisplayPort 1.1a signals. Due to the ultra-low ON-state capacitance (4.1 pF typ) and resistance (7 Ω typ), these switches have a signal bit rate (BR) of 5 Gbps, ideal for high frequency data signals. This switch pinout is designed to be used in ATX form factor desktop PCs and is available in a space-saving WQFN package. The NCN2612 uses 80% less quiescent power than other comparable PCIe switches.

Features

- V_{DD} Power Supply from 3 V to 3.6 V
- Low Supply Current 250 μ A typ
- 6 Differential Channels 2:1 MUX/DEMUX
- Compatible with Display Port 1.1a & PCIe 2.0
- Data Rate: Supports 5 Gbps
- Low Ron Resistance: 7 Ω typ
- Low Con Capacitance: 4.1 pF
- Space Saving Small WQFN-56 Package
- This is a Pb-Free Device

Typical Applications

- Notebook Computers
- Desktop Computers
- Server/Storage Networks



ON Semiconductor®

<http://onsemi.com>

MARKING DIAGRAM

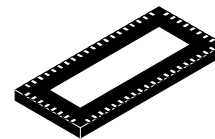

WQFN56
CASE 510AK

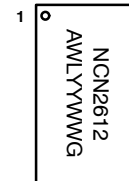

A = Assembly Location
WL = Wafer Lot
YY = Year
WW = Work Week
G = Pb-Free Package

ORDERING INFORMATION

Device	Package	Shipping†
NCN2612MTTWG	WQFN56 (Pb-Free)	2000 / Tape & Reel

†For information on tape and reel specifications, including part orientation and tape sizes, please refer to our Tape and Reel Packaging Specifications Brochure, BRD8011/D.

NCN2612

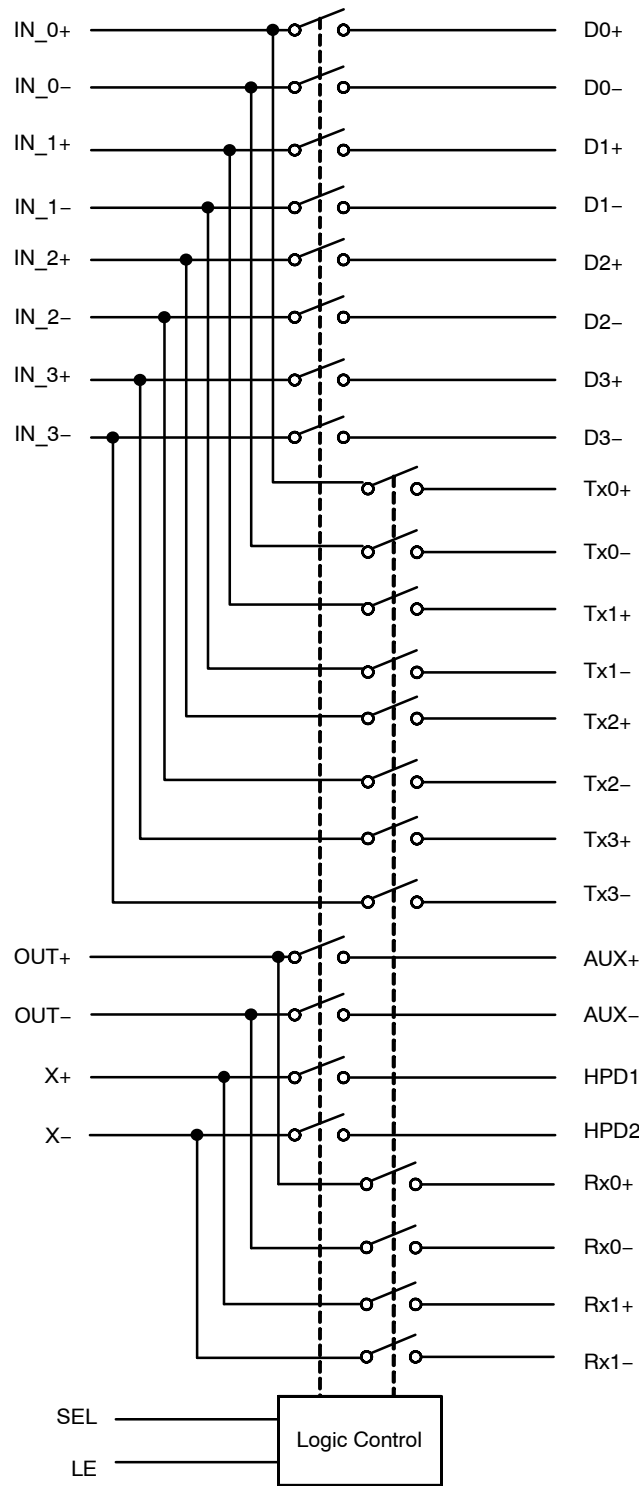

Figure 1. NCN2612 Block Diagram

TRUTH TABLE (SEL Control)

Function	SEL
PCI_Express Gen2 Path is Active (Tx, Rx)	L
Digital Video Port is Active (Dx, HPDx, AUX)	H

TRUTH TABLE (Latch Control)

LE	Internal Mux Select
0	Respond to Changes on SEL
1	Latched

NCN2612

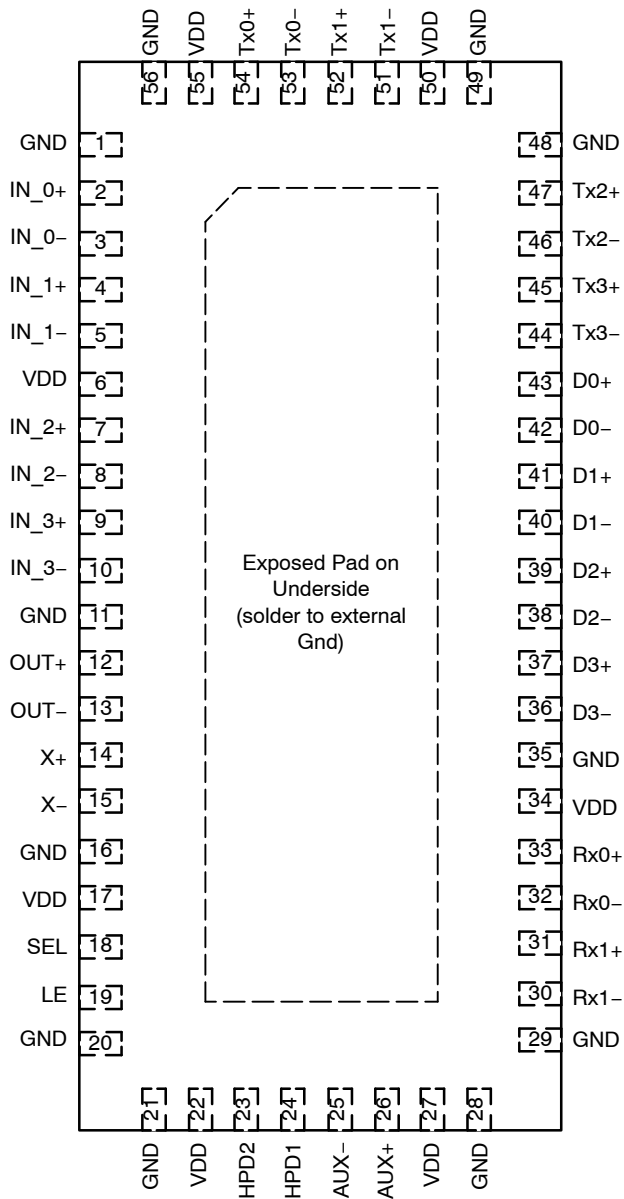

**Figure 2. Pinout
(Top View)**

NCN2612

PIN FUNCTION AND DESCRIPTION

Pin	Name	Description
6, 17, 22, 27, 34, 50, 55	VDD	DC Supply, 3.3 V \pm 10%
1, 11, 16, 20, 21, 28, 29, 35, 48, 49, 56	GND	Power Ground.
Exposed Pad	-	The exposed pad on the backside of package is internally connected to Gnd. Externally the exposed pad should also be user-connected to GND.
2	IN_0+	Differential input from GMCH PCIE outputs. IN_0+ makes a differential pair with IN_0-.
3	IN_0-	Differential input from GMCH PCIE outputs. IN_0- makes a differential pair with IN_0+.
4	IN_1+	Differential input from GMCH PCIE outputs. IN_1+ makes a differential pair with IN_1-.
5	IN_1-	Differential input from GMCH PCIE outputs. IN_1- makes a differential pair with IN_1+.
7	IN_2+	Differential input from GMCH PCIE outputs. IN_2+ makes a differential pair with IN_2-.
8	IN_2-	Differential input from GMCH PCIE outputs. IN_2- makes a differential pair with IN_2+.
9	IN_3+	Differential input from GMCH PCIE outputs. IN_3+ makes a differential pair with IN_3-.
10	IN_3-	Differential input from GMCH PCIE outputs. IN_3- makes a differential pair with IN_3+.
12	OUT+	Pass-through output from AUX+ input when SEL = 1. Pass-through output from Rx0+ input when SEL = 0.
13	OUT-	Pass-through output from AUX- input when SEL = 1. Pass-through output from Rx0- input when SEL = 0.
14	X+	X+ is an analog pass-through output corresponding to Rx1+.
15	X-	X- is an analog pass-through output corresponding to the Rx1- input. The path from Rx1- to X- must be matched with the path from Rx1+ to X+. X+ and X- form a differential pair when the pass-through mux mode is selected.
18	SEL	SEL controls the mux through a flow-through latch. SEL = 0 for PCIE Mode; SEL = 1 for DP Mode
19	LE	The latch gate is controlled by LE.
43, 42	D0+, D0-	Analog pass-through output#1 corresponding to IN_0+ and IN_0-, when SEL = 1.
41, 40	D1+, D1-	Analog pass-through output#1 corresponding to IN_1+ and IN_1-, when SEL = 1.
39, 38	D2+, D2-	Analog pass-through output#1 corresponding to IN_2+ and IN_2-, when SEL = 1.
37, 36	D3+, D3-	Analog pass-through output#1 corresponding to IN_3+ and IN_3-, when SEL = 1.
54, 53	Tx0+, Tx0-	Analog pass-through output#2 corresponding to IN_0+ and IN_0- when SEL = 0.
52, 51	Tx1+, Tx1-	Analog pass-through output#2 corresponding to IN_1+ and IN_1- when SEL = 0.
47, 46	Tx2+, Tx2-	Analog pass-through output#2 corresponding to IN_2+ and IN_2- when SEL = 0.
45, 44	Tx3+, Tx3-	Analog pass-through output#2 corresponding to IN_3+ and IN_3- when SEL = 0.
26	AUX+	Differential input from HDMI/DP connector. AUX+ makes a differential pair with AUX-. AUX+ is passed through to the OUT+ pin when SEL = 1.
25	AUX-	Differential input from HDMI/DP connector. AUX- makes a differential pair with AUX+. AUX- is passed through to the OUT- pin when SEL = 1.
24	HPD1	Positive low frequency HPD input handshake protocol signal.
23	HPD2	Negative low frequency HPD input handshake protocol signal (normally not connected).
33	Rx0+	Differential input from PCIE connector or device. Rx0+ makes a differential pair with Rx0-. Rx0+ is passed through to the OUT+ pin when SEL = 0.
32	Rx0-	Differential input from PCIE connector or device. Rx0- makes a differential pair with Rx0+. Rx0- is passed through to the OUT- pin when SEL = 0.
31	Rx1+	Differential input from PCIE connector or device. Rx1+ makes a differential pair with Rx1-. Rx1+ is passed through to the X+ pin when SEL = 0.
30	Rx1-	Differential input from PCIE connector or device. Rx1- makes a differential pair with Rx1+. Rx1- is passed through to the X- pin on the path that matches the Rx1+ to X+ pin.

NCN2612

MAXIMUM RATINGS

Parameter	Symbol	Rating	Unit
Power Supply Voltages	V_{DD}	$-0.5 \leq V_{DD} \leq 5.3$	V
Input/Output Voltage Range of the Switch	V_I & V_O	$-0.7 \leq V_I \leq V_{DD} + 0.3$	V
Selection Pin Voltages	V_{SEL}	$-0.5 \leq V_I \leq V_{DD} + 0.3$	V
Continuous Current Through One Switch Channel	I_{IO}	± 120	mA
Maximum Junction Temperature (Note 1)	T_J	150	°C
Operating Ambient Temperature	T_A	-40 to +85	°C
Storage Temperature Range	T_{stg}	-65 to +150	°C
Thermal Resistance, Junction-to-Air (Note 2)	$R_{\theta JA}$	37	°C/W

Stresses exceeding Maximum Ratings may damage the device. Maximum Ratings are stress ratings only. Functional operation above the Recommended Operating Conditions is not implied. Extended exposure to stresses above the Recommended Operating Conditions may affect device reliability.

1. Power dissipation must be considered to ensure maximum junction temperature (T_J) is not exceeded.
2. This parameter is based on EIA/JEDEC 51-7 with a 4-layer PCB, 80mm x 80mm, two 1oz Cu material internal planes and top planes of 2oz Cu material.

NCN2612

ELECTRICAL CHARACTERISTICS ($V_{DD} = +3.3V \pm 10\%$, $T_A = -40^\circ\text{C}$ to $+85^\circ\text{C}$ and T_J up to 125°C , unless otherwise noted. All Typical values are at $V_{DD} = +3.3V$, $T_A = +25^\circ\text{C}$, unless otherwise noted)

Symbol	Characteristics	Conditions	Min	Typ	Max	Unit
--------	-----------------	------------	-----	-----	-----	------

POWER SUPPLY

V_{DD}	Supply Voltage Range		3.0	3.3	3.6	V
I_{DD}	Power Supply Current	$V_{DD} = 3.6V$, $V_{IN} = \text{GND or } V_{DD}$		250	500	μA

DATA SWITCH PERFORMANCE (for both PCIe and Display Port applications, unless otherwise noted)

V_{IN}	Data Input/Output Voltage Range		-0.1		V_{DD}	V
R_{ON}	On Resistance (Tx, Rx)	$V_{DD} = 3V$, $0V \leq V_{IN} \leq V_{DD}$, $I_{IN} = 40\text{ mA}$		7	13	Ω
R_{ON}	On Resistance (Dx,HP-Dx,AUX)	$V_{DD} = 3V$, $0V \leq V_{IN} \leq V_{DD}$, $I_{IN} = 40\text{ mA}$		7.5	13	Ω
$R_{ON(\text{flat})}$	On Resistance Flatness	$V_{DD} = 3V$, $0V \leq V_{IN} \leq V_{DD}$, $I_{IN} = 40\text{ mA}$		0.1	1.24	Ω
ΔR_{ON}	On Resistance Matching (Tx, Rx)	$V_{DD} = 3V$, $V_{IN} = 0V$, $I_{IN} = 40\text{ mA}$			0.35	Ω
ΔR_{ON}	On Resistance Matching (Dx,HPDx,AUX)	$V_{DD} = 3V$, $V_{IN} = 0V$, $I_{IN} = 40\text{ mA}$			0.35	Ω
C_{ON}	On Capacitance	$f = 1\text{ MHz}$, Switch On, Open Output		4.1		pF
C_{OFF}	Off Capacitance	$f = 1\text{ MHz}$, Switch Off		2.6		pF
I_{ON}	On Leakage Current (IN_/X_/OUT_)	$V_{DD} = +3.6V$, $V_{IN_} = V_{X_} = V_{OUT_} = 0V$, $+1.2V$; $V_{D_}$ or $V_{TX_}$ or $V_{HPD_}$ or $V_{RX_}$ or $V_{AUX_} = \text{unconnected}$	-1		+1	μA
I_{OFF}	Off Leakage Current (D_/TX_/HPD_/RX_/AUX_)	$V_{DD} = +3.6V$, $V_{IN_} = V_{X_} = V_{OUT_} = 0V$, $+1.2V$; $V_{D_}$ or $V_{TX_}$; $V_{HPD_}/AUX_}$ or $V_{RX_} = 1.2V$, $0V$	-1		+1	μA

CONTROL LOGIC CHARACTERISTICS (SEL and LE pins)

V_{IL}	Off voltage input		0		0.8	V
V_{IH}	High voltage input		2		V_{DD}	V
I_{IN}	Off voltage input	$V_{IN} = 0V$ or V_{DD}	-1		+1	μA
C_{IN}	High voltage input	$f = 1\text{ MHz}$		1		pF

DYNAMIC CHARACTERISTICS

BR	Signal Data Rate	$R_S = R_L = 100\ \Omega$ differential		5		Gbps
I_{LOSS}	Differential Insertion Loss	$R_S = R_L = 50\ \Omega$, $F = 2.7\text{ GHz}$		-4		dB
		$R_S = R_L = 50\ \Omega$, $F = 5\text{ GHz}$		-7		
		$R_S = R_L = 50\ \Omega$, $F = 7.5\text{ GHz}$		-13		
V_{ISO}	Differential Off Isolation	$R_S = R_L = 50\ \Omega$, $F = 100\text{ MHz}$		-41		dB
		$R_S = R_L = 50\ \Omega$, $F = 1.35\text{ GHz}$		-19		
		$R_S = R_L = 50\ \Omega$, $F = 3\text{ GHz}$		-16		
X_{talk}	Differential Crosstalk	$R_S = R_L = 50\ \Omega$, $F = 2.5\text{ GHz}$		-27		dB
		$R_S = R_L = 50\ \Omega$, $F = 5\text{ GHz}$		-20		
		$R_S = R_L = 50\ \Omega$, $F = 7.5\text{ GHz}$		-10		

NCN2612

SWITCHING CHARACTERISTICS ($V_{DD} = +3.3\text{ V}$, $T_A = 25^\circ\text{C}$, unless otherwise specified)

Symbol	Characteristics	Conditions	Min	Typ	Max	Unit
T_{SK1}	Bit-to-bit skew within same differential channel	$R_S = 50\ \Omega$, $R_L = 200\ \Omega$, $C_L = 4\ \text{pF}$		7		ps
T_{SK2}	Channel-to-channel skew	$R_S = 50\ \Omega$, $R_L = 200\ \Omega$, $C_L = 4\ \text{pF}$		55		ps

SELECTION PINS SWITCHING CHARACTERISTICS ($V_{DD} = +3.3\text{ V}$, $T_A = 25^\circ\text{C}$, unless otherwise specified)

Symbol	Characteristics	Conditions	Min	Typ	Max	Unit
$T_{SELO\text{N}}$	SEL to Switch turn ON time	V_{DX_A} or $V_{DX_B} = +1.0\text{ V}$, $R_L = 50\ \Omega$, V_{HPD_X} or $V_{AUX_X} = +1.0\text{ V}$, $R_L = 50\ \Omega$, $LE = V_{DD}$, $C_L = 100\ \text{pF}$		8	20	ns
$T_{SELO\text{F}}$	SEL to Switch turn OFF time	V_{DX_A} or $V_{DX_B} = +1.0\text{ V}$, $R_L = 50\ \Omega$, V_{HPD_X} or $V_{AUX_X} = +1.0\text{ V}$, $R_L = 50\ \Omega$, $LE = V_{DD}$, $C_L = 100\ \text{pF}$		5	10	ns
$T_{SE\text{T}}$	LE setup time SEL to LE	V_{DX_A} or $V_{DX_B} = +1.0\text{ V}$, $R_L = 50\ \Omega$, V_{HPD_X} or $V_{AUX_X} = +1.0\text{ V}$, $R_L = 50\ \Omega$, $LE = V_{DD}$, $C_L = 100\ \text{pF}$		1		ns
$T_{SE\text{H}}$	LE hold time LE to SEL	V_{DX_A} or $V_{DX_B} = +1.0\text{ V}$, $R_L = 50\ \Omega$, V_{HPD_X} or $V_{AUX_X} = +1.0\text{ V}$, $R_L = 50\ \Omega$, $LE = V_{DD}$, $C_L = 100\ \text{pF}$		1		ns

NOTE: Device will meet the specifications after thermal equilibrium has been established when mounted in a test socket or printed circuit board with maintained transverse airflow greater than 500 lfpm. Electrical parameters are guaranteed only over the declared operating temperature range. Functional operation of the device exceeding these conditions is not implied. Device specification limit values are applied individually under normal operating conditions and not valid simultaneously.

NCN2612

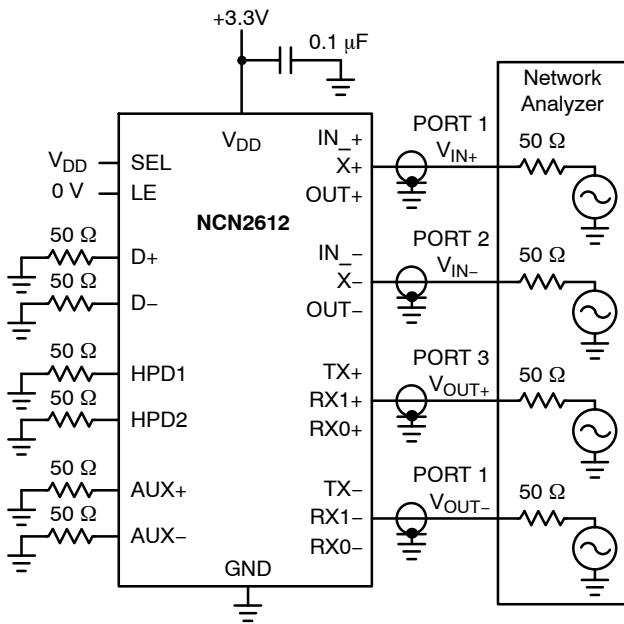

$$\text{Differential Insertion Loss} = 20\log\left(\frac{V_{OUT+} - V_{OUT-}}{V_{IN+} - V_{IN-}}\right)$$

Figure 3. Differential Insertion Loss/Differential Return Loss

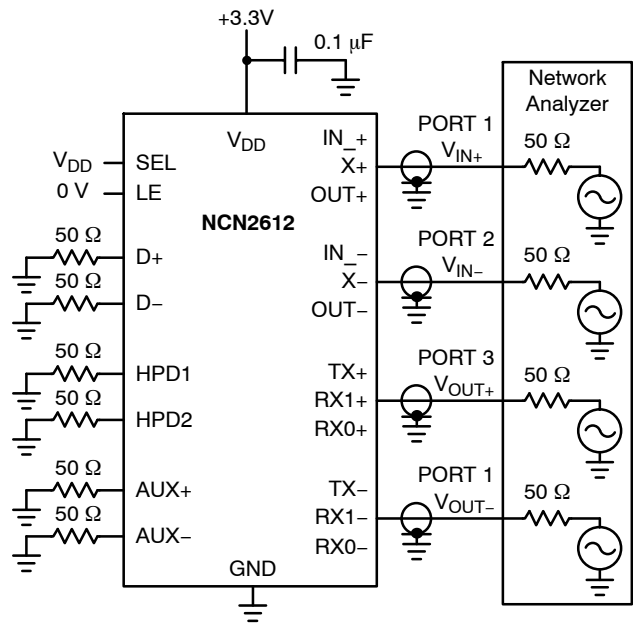

$$\text{Differential Off Isolation} = 20\log\left(\frac{V_{OUT+} - V_{OUT-}}{V_{IN+} - V_{IN-}}\right)$$

Figure 4. Differential Off-Isolation

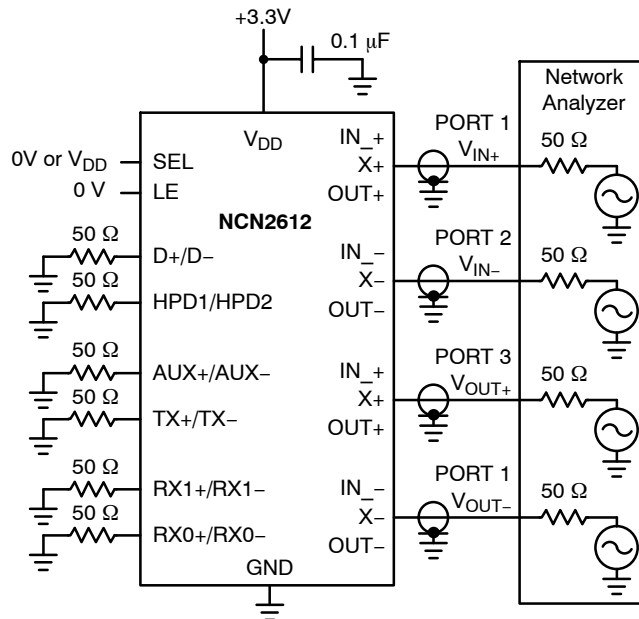

$$\text{Differential Crosstalk} = 20\log\left(\frac{V_{OUT+} - V_{OUT-}}{V_{IN+} - V_{IN-}}\right)$$

Figure 5. Differential Crosstalk

Measurements are standardized against shorts at IC terminals.

Differential OFF-Isolation is measured between IN₋ and "OFF" D or TX, X and "OFF" HPD or RX1, OUT and "OFF" AUX or RX0 terminal on each switch under Figure 3.

Differential ON-Isolation is measured between IN₋ and "ON" D or TX, X and "ON" HPD or RX1, OUT and "ON" AUX or RX0 terminal on each switch under Figure 4.

Differential Crosstalk is measured between any two pairs.

MECHANICAL CASE OUTLINE

PACKAGE DIMENSIONS

ON Semiconductor®



WQFN56 5x11, 0.5P
CASE 510AK-01
ISSUE A

DATE 02 MAR 2010

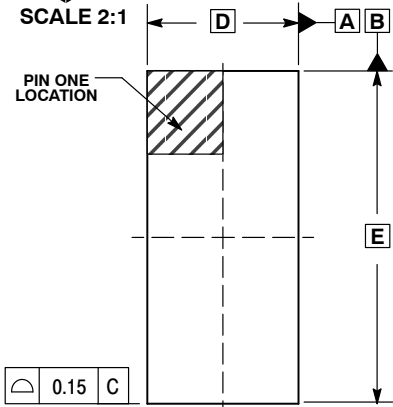
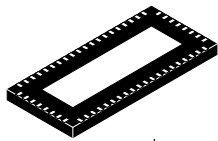

TOP VIEW

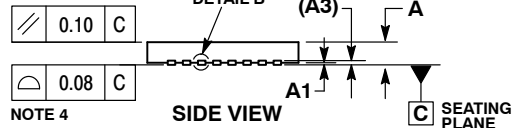

SIDE VIEW

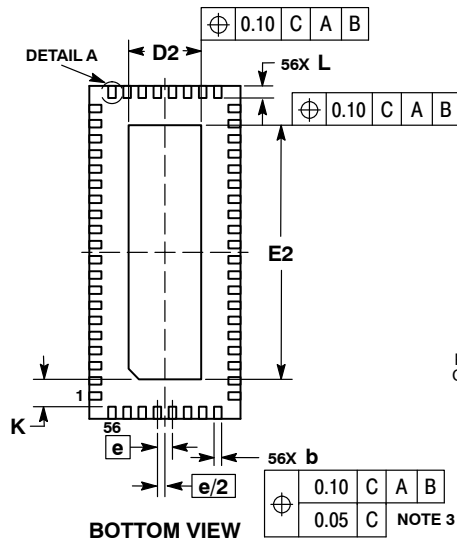

BOTTOM VIEW

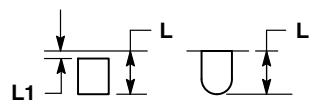

DETAIL A
ALTERNATE
CONSTRUCTIONS

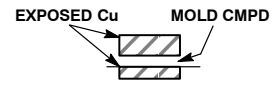

DETAIL B
ALTERNATE
CONSTRUCTION

NOTES:

1. DIMENSIONING AND TOLERANCING PER ASME Y14.5M, 1994.
2. CONTROLLING DIMENSIONS: MILLIMETERS.
3. DIMENSION b APPLIES TO PLATED TERMINAL AND IS MEASURED BETWEEN 0.15 AND 0.30mm FROM THE TERMINAL TIP.
4. COPLANARITY APPLIES TO THE EXPOSED PAD AS WELL AS THE TERMINALS.

MILLIMETERS		
DIM	MIN	MAX
A	0.70	0.80
A1	---	0.05
A3	0.20	REF
b	0.20	0.30
D	5.00	BSC
D2	2.30	2.50
E	11.00	BSC
E2	8.30	8.50
e	0.50	BSC
K	0.20	MIN
L	0.30	0.50
L1	---	0.15

RECOMMENDED SOLDERING FOOTPRINT

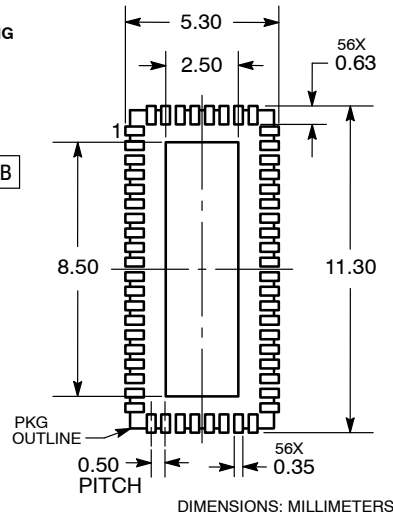

GENERIC MARKING DIAGRAM*

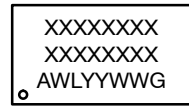

- XXXXX = Specific Device Code
- A = Assembly Location
- WL = Wafer Lot
- YY = Year
- WW = Work Week
- G = Pb-Free Package

*This information is generic. Please refer to device data sheet for actual part marking. Pb-Free indicator, "G", may or not be present.

DOCUMENT NUMBER:	98AON45390E	Electronic versions are uncontrolled except when accessed directly from the Document Repository. Printed versions are uncontrolled except when stamped "CONTROLLED COPY" in red.
DESCRIPTION:	WQFN56 5x11, 0.5P	PAGE 1 OF 1

ON Semiconductor and are trademarks of Semiconductor Components Industries, LLC dba ON Semiconductor or its subsidiaries in the United States and/or other countries. ON Semiconductor reserves the right to make changes without further notice to any products herein. ON Semiconductor makes no warranty, representation or guarantee regarding the suitability of its products for any particular purpose, nor does ON Semiconductor assume any liability arising out of the application or use of any product or circuit, and specifically disclaims any and all liability, including without limitation special, consequential or incidental damages. ON Semiconductor does not convey any license under its patent rights nor the rights of others.

onsemi, **Onsemi**, and other names, marks, and brands are registered and/or common law trademarks of Semiconductor Components Industries, LLC dba "**onsemi**" or its affiliates and/or subsidiaries in the United States and/or other countries. **onsemi** owns the rights to a number of patents, trademarks, copyrights, trade secrets, and other intellectual property. A listing of **onsemi**'s product/patent coverage may be accessed at www.onsemi.com/site/pdf/Patent-Marking.pdf. **onsemi** reserves the right to make changes at any time to any products or information herein, without notice. The information herein is provided "as-is" and **onsemi** makes no warranty, representation or guarantee regarding the accuracy of the information, product features, availability, functionality, or suitability of its products for any particular purpose, nor does **onsemi** assume any liability arising out of the application or use of any product or circuit, and specifically disclaims any and all liability, including without limitation special, consequential or incidental damages. Buyer is responsible for its products and applications using **onsemi** products, including compliance with all laws, regulations and safety requirements or standards, regardless of any support or applications information provided by **onsemi**. "Typical" parameters which may be provided in **onsemi** data sheets and/or specifications can and do vary in different applications and actual performance may vary over time. All operating parameters, including "Typicals" must be validated for each customer application by customer's technical experts. **onsemi** does not convey any license under any of its intellectual property rights nor the rights of others. **onsemi** products are not designed, intended, or authorized for use as a critical component in life support systems or any FDA Class 3 medical devices or medical devices with a same or similar classification in a foreign jurisdiction or any devices intended for implantation in the human body. Should Buyer purchase or use **onsemi** products for any such unintended or unauthorized application, Buyer shall indemnify and hold **onsemi** and its officers, employees, subsidiaries, affiliates, and distributors harmless against all claims, costs, damages, and expenses, and reasonable attorney fees arising out of, directly or indirectly, any claim of personal injury or death associated with such unintended or unauthorized use, even if such claim alleges that **onsemi** was negligent regarding the design or manufacture of the part. **onsemi** is an Equal Opportunity/Affirmative Action Employer. This literature is subject to all applicable copyright laws and is not for resale in any manner.

PUBLICATION ORDERING INFORMATION

LITERATURE FULFILLMENT:

Email Requests to: orderlit@onsemi.com

onsemi Website: www.onsemi.com

TECHNICAL SUPPORT

North American Technical Support:

Voice Mail: 1 800-282-9855 Toll Free USA/Canada

Phone: 011 421 33 790 2910

Europe, Middle East and Africa Technical Support:

Phone: 00421 33 790 2910

For additional information, please contact your local Sales Representative