

MC10E1651

5V, -5V Dual ECL Output Comparator with Latch

The MC10E1651 is fabricated using ON Semiconductor's advanced MOSAIC III process. The MC10E1651 incorporates a fixed level of input hysteresis as well as output compatibility with 10 KH logic devices. In addition, a latch is available allowing a sample and hold function to be performed. The device is available in a 20-pin surface mount package.

The latch enable (\overline{LEN}_a and \overline{LEN}_b) input pins operate from standard ECL 10 KH logic levels. When the latch enable is at a logic high level, the MC10E1651 acts as a comparator; hence, Q will be at a logic high level if $V_1 > V_2$ (V_1 is more positive than V_2). \overline{Q} is the complement of Q. When the latch enable input goes to a low logic level, the outputs are latched in their present state providing the latch enable setup and hold time constraints are met.

Features

- Typical 3.0 dB Bandwidth > 1.0 GHz
- Typical V to Q Propagation Delay of 775 ps
- Typical Output Rise/Fall of 350 ps
- Common Mode Range -2.0 V to +3.0 V
- Individual Latch Enables
- Differential Outputs
- 28 mV Input Hysteresis
- Operating Mode: $V_{CC} = 5.0$ V, $V_{EE} = -5.2$ V, GND = 0 V
- No Internal Input Pulldown Resistors
- ESD Protection: > 2 kV Human Body Model, > 100 V Machine Model
- Meets or Exceeds JEDEC Spec EIA/JESD78 IC Latchup Test
- Moisture Sensitivity Level 3
For Additional Information, see Application Note AND8003/D
- Flammability Rating: UL 94 V-0 @ 0.125 in, Oxygen Index: 28 to 34
- Transistor Count = 85 devices
- These are Pb-Free Devices*



ON Semiconductor®

<http://onsemi.com>

MARKING DIAGRAM

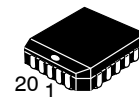

PLCC-20
FN SUFFIX
CASE 775

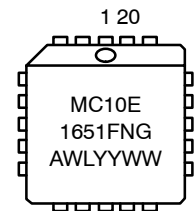

A = Assembly Location
WL = Wafer Lot
YY = Year
WW = Work Week
G = Pb-Free Package

ORDERING INFORMATION

See detailed ordering and shipping information in the package dimensions section on page 7 of this data sheet.

*For additional information on our Pb-Free strategy and soldering details, please download the ON Semiconductor Soldering and Mounting Techniques Reference Manual, SOLDERRM/D.

MC10E1651

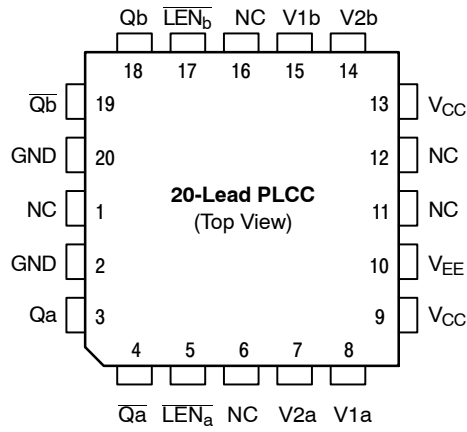

* All V_{CC} and V_{CC0} pins are NOT tied together on the die.

Warning: All V_{CC} , GND, and V_{EE} pins must be externally connected to Power Supply to guarantee proper operation.

Figure 1. Logic Diagrams and Pinout Assignments

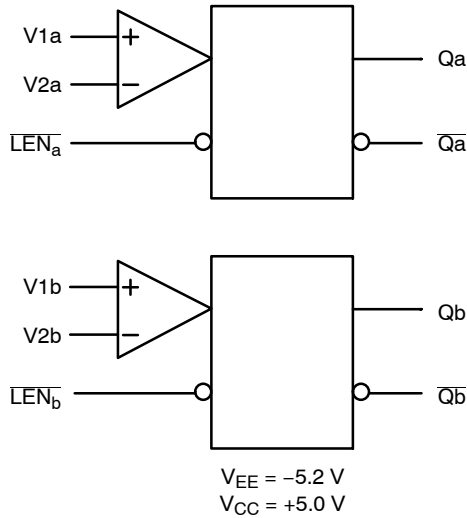

Figure 2. Logic Diagram

Table 1. PIN DESCRIPTION

PIN	FUNCTION
Qa, \overline{Qa}	ECL Differential Outputs (a)
Qb, \overline{Qb}	ECL Differential Outputs (b)
\overline{LENa} , \overline{LENb}	ECL Latch Enable
V1a, V1b	Input Comparator 1
V2a, V2b	Input Comparator 2
V_{CC}	Positive Supply
V_{EE}	Negative Supply
NC	No Connect
GND	Ground

Table 2. FUNCTION TABLE

\overline{LEN}	V1, V2	Function
H	$V1 > V2$	H
H	$V1 < V2$	L
L	X	Latched

MC10E1651

Table 3. MAXIMUM RATINGS

Symbol	Parameter	Condition 1	Condition 2	Rating	Unit
V _{SUP}	Total Supply Voltage	V _{EE} + V _{CC}		12.0	V
V _{PP}	Differential Input Voltage	V ₁ - V ₂		3.7	V
V _I	Input Voltage			V _{EE} ≤ V _I ≤ V _{CC}	V
I _{out}	Output Current	Continuous Surge		50 100	mA mA
T _A	Operating Temperature Range			0 to +85	°C
T _{stg}	Storage Temperature Range			-65 to +150	°C
θ _{JA}	Thermal Resistance (Junction-to-Ambient)	0 lfpm 500 lfpm	28 PLCC 28 PLCC	63.5 43.5	°C/W °C/W
θ _{JC}	Thermal Resistance (Junction-to-Case)	Standard Board	28 PLCC	22 to 26	°C/W
V _{EE}	Operating Range	GND = 0 V		-4.2 to -5.7	V
T _{sol}	Wave Solder Pb-Free	≤ 3 sec @ 260°C		265	°C

Stresses exceeding Maximum Ratings may damage the device. Maximum Ratings are stress ratings only. Functional operation above the Recommended Operating Conditions is not implied. Extended exposure to stresses above the Recommended Operating Conditions may affect device reliability.

Table 4. DC CHARACTERISTICS V_{CC} = +5.0 V ±5%; V_{EE} = -5.2 V ±5%, GND = 0 V (Note 1)

Symbol	Characteristic	0°C			25°C			85°C			Unit
		Min	Typ	Max	Min	Typ	Max	Min	Typ	Max	
V _{OH}	Output HIGH Voltage (Note 1)	-1020		-840	-980		-810	-920		-735	mV
V _{OL}	Output Low Voltage (Note 1)	-1950		-1630	-1950		-1630	-1950		-1600	mV
V _{IL}	Input LOW Voltage (LEN) (Note 1)	-1.95		-1.48	-1.95		-1.48	-1.95		-1.45	mV
V _{IH}	Input HIGH Voltage (LEN) (Note 1)	-1.17		-0.84	-1.13		-0.81	-1.07		-0.735	mV
I _I	Input Current (V ₁ , V ₂)			65			65			65	μA
I _{IH}	Input HIGH Current (LEN)			150			150			150	μA
I _{CC}	Positive Supply Current			50			50			50	mA
I _{EE}	Negative Supply Current			-55			-55			-55	mA
V _{CMR}	Common Mode Range (Note 2)	-2.0		3.0	-2.0		3.0	-2.0		3.0	V
Hys	Hysteresis		27			27			30		mV
V _{skew}	Hysteresis Skew (Note 3)		-1.0			-1.0			0		mV
C _{in}	Input Capacitance			2			2			2	pF

NOTE: Device will meet the specifications after thermal equilibrium has been established when mounted in a test socket or printed circuit board with maintained transverse airflow greater than 500 lfpm. Electrical parameters are guaranteed only over the declared operating temperature range. Functional operation of the device exceeding these conditions is not implied. Device specification limit values are applied individually under normal operating conditions and not valid simultaneously.

1. Input V_{IL} and V_{IH} parameters vary 1:1 with V_{CC}. Output V_{OH} and V_{OL} parameters vary 1:1 with GND.
2. V_{CMR} Min varies 1:1 with V_{EE}; Max varies 1:1 with V_{CC}.
3. Hysteresis skew (V_{skew}) is provided to indicate the offset of the hysteresis window. For example, at 25°C the nominal hysteresis value is 27 mV and the V_{skew} value indicates that the hysteresis was skewed from the reference level by 1mV in the negative direction. Hence the hysteresis window ranged from 14 mV below the reference level to 13 mV above the reference level. All hysteresis measurements were determined using a reference voltage of 0 mV.

MC10E1651

Table 5. AC CHARACTERISTICS $V_{CC} = +5.0\text{ V} \pm 5\%$; $V_{EE} = -5.2\text{ V} \pm 5\%$, $GND = 0\text{ V}$ (Note 4)

Symbol	Characteristic	0°C			25°C			85°C			Unit
		Min	Typ	Max	Min	Typ	Max	Min	Typ	Max	
f_{MAX}	Maximum Toggle Frequency		TBD			> 1.0			TBD		GHz
t_{PLH} t_{PHL}	Propagation Delay to Output (Note 4) V to Q \overline{LEN} to Q	750 550	900 725	1050 900	775 550	925 750	1075 900	850 650	1025 825	1200 1000	ps
t_s	Setup Time V	450	300		450	300		550	350		ps
t_h	Enable Hold Time V	-50	-250		-50	-250		-100	-250		ps
t_{pw}	Minimum Pulse Width \overline{LEN}	400			400			400			ps
t_{skew}	Within Device Skew (Note 5)		15			15			15		ps
t_{JITTER}	Cycle-to-Cycle Jitter		TBD			TBD			TBD		ps
T_{DE}	Delay Dispersion (ECL Levels) (Notes 6, 7) (Notes 6, 8)					100 60					ps
T_{DL}	Delay Dispersion (TTL Levels) (Notes 9, 10) (Notes 8, 9)					350 100					ps
t_r t_f	Rise/Fall Times (20-80%)	225	325	475	225	325	475	250	375	500	ps

NOTE: Device will meet the specifications after thermal equilibrium has been established when mounted in a test socket or printed circuit board with maintained transverse airflow greater than 500 lpm. Electrical parameters are guaranteed only over the declared operating temperature range. Functional operation of the device exceeding these conditions is not implied. Device specification limit values are applied individually under normal operating conditions and not valid simultaneously.

4. Input V_{IL} and V_{IH} parameters vary 1:1 with V_{CC} , output V_{OH} and V_{OL} parameters vary 1:1 with GND .
5. t_{skew} is the propagation delay skew between comparator A and comparator B for a particular part under identical input conditions.
6. Refer to figure 4 and note that the input is at 850mV ECL levels with the input threshold range between the 20% and 80% points. The delay is measured from the crosspoint of the input signal and the threshold value to the crosspoint of the Q and \overline{Q} output signals.
7. The slew rate is 0.25 V/NS for input rising edges.
8. The slew rate is 0.75 V/NS for input rising edges.
9. Refer to Figure 5 and note that the input is at 2.5 V TTL levels with the input threshold range between the 20% and 80% points. The delay is measured from the crosspoint of the input signal and the threshold value to the crosspoint of the Q and \overline{Q} output signals.
10. The slew rate is 0.3 V/NS for input rising edges.

APPLICATIONS INFORMATION

The timing diagram (Figure 3.) is presented to illustrate the MC10E1651's compare and latch features. When the signal on the $\overline{\text{LEN}}$ pin is at a logic high level, the device is operating in the "compare mode," and the signal on the input arrives at the output after a nominal propagation delay (t_{PHL} , t_{PLH}). The input signal must be asserted for a time, t_s , prior to the negative going transition on $\overline{\text{LEN}}$ and held for a time, t_h , after the $\overline{\text{LEN}}$ transition. After time t_h , the latch is operating in the "latch mode," thus transitions on the input do not appear at the output. The device continues to operate in the "latch mode" until the latch is asserted once again. Moreover, the $\overline{\text{LEN}}$ pulse must meet the minimum pulse width (t_{pw}) requirement to effect the correct input-output relationship. Note that the $\overline{\text{LEN}}$ waveform in Figure 3. shows the $\overline{\text{LEN}}$ signal swinging around a reference labeled V_{BBINT} ; this waveform emphasizes the requirement that $\overline{\text{LEN}}$ follow typical ECL 10KH logic levels because

V_{BBINT} is the internally generated reference level, hence is nominally at the ECL V_{BB} level.

Finally, V_{OD} is the input voltage overdrive and represents the voltage level beyond the threshold level (V_{THR}) to which the input is driven. As an example, if the threshold level is set on one of the comparator inputs as 80 mV and the input signal swing on the complementary input is from zero to 100 mV, the positive going overdrive would be 20 mV and the negative going overdrive would be 80 mV. The result of differing overdrive levels is that the devices have shorter propagation delays with greater overdrive because the threshold level is crossed sooner than the case of lower overdrive levels. Typically, semiconductor manufactures refer to the threshold voltage as the input offset voltage (VOS) since the threshold voltage is the sum of the externally supplied reference voltage and inherent device offset voltage.

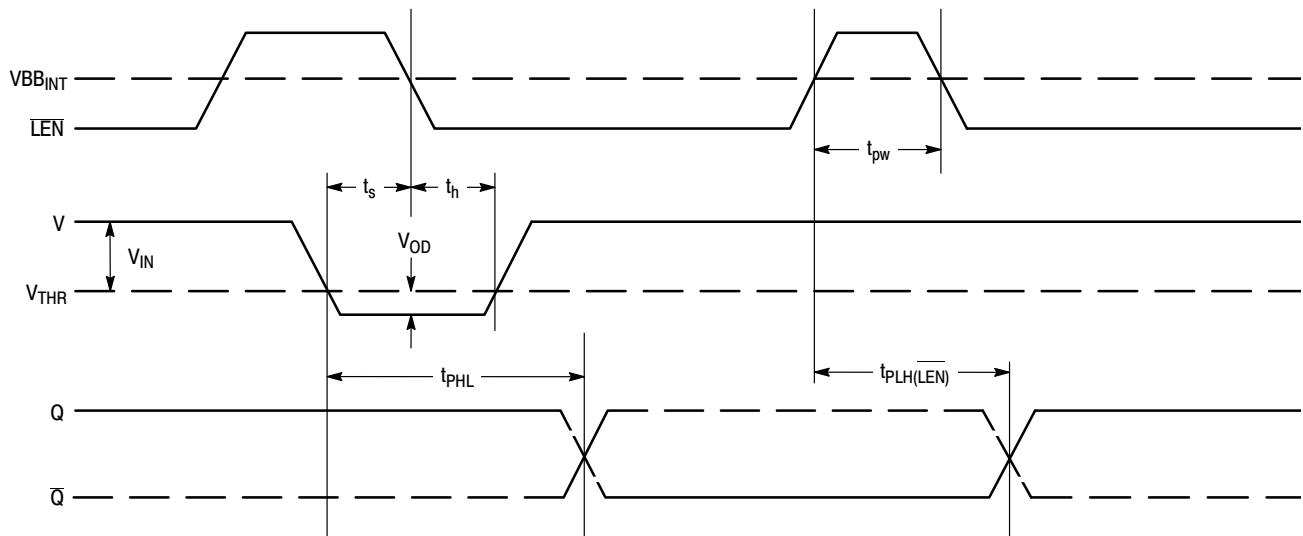

Figure 3. Input/Output Timing Diagram

DELAY DISPERSION

Under a constant set of input conditions comparators have a specified nominal propagation delay. However, since propagation delay is a function of input slew rate and input voltage overdrive the delay dispersion parameters, T_{DE} and T_{DT} , are provided to allow the user to adjust for these variables (where T_{DE} and T_{DT} apply to inputs with standard ECL and TTL levels, respectively).

Figure 4 and Figure 5 define a range of input conditions which incorporate varying input slew rates and input voltage overdrive. For input parameters that adhere to these constraints the propagation delay can be described as:

$$T_{NOM} \pm T_{DE} \text{ (or } T_{DT}\text{)}$$

where T_{NOM} is the nominal propagation delay. T_{NOM} accounts for nonuniformity introduced by temperature and voltage variability, whereas the delay dispersion parameter takes into consideration input slew rate and input voltage overdrive variability. Thus a modified propagation delay can be approximated to account for the effects of input conditions that differ from those under which the parts were tested. For example, an application may specify an ECL input with a slew rate of 0.25 V/NS, an overdrive of 17 mV and a temperature of 25°C, the delay dispersion parameter would be 100 ps. The modified propagation delay would be

$$775 \text{ ps} \pm 100 \text{ ps}$$

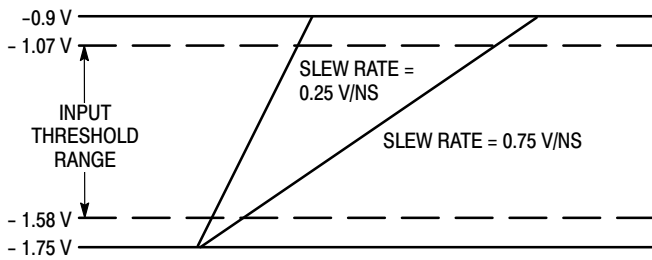

Figure 4. ECL Dispersion Test Input Conditions

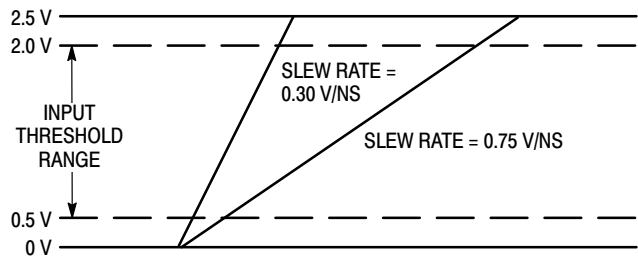
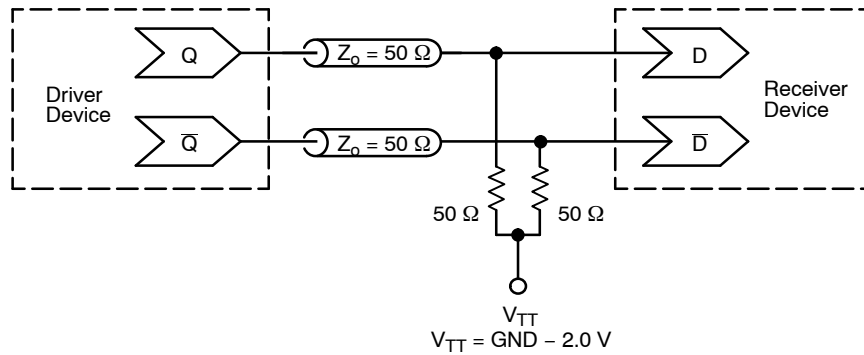

Figure 5. TTL Dispersion Test Input Conditions

MC10E1651



**Figure 6. Typical Termination for Output Driver and Device Evaluation
(See Application Note AND8020/D – Termination of ECL Logic Devices.)**

ORDERING INFORMATION

Device	Package	Shipping [†]
MC10E1651FNG	PLCC-20 (Pb-Free)	46 Units / Rail
MC10E1651FNR2G	PLCC-20 (Pb-Free)	500 / Tape & Reel

[†]For information on tape and reel specifications, including part orientation and tape sizes, please refer to our Tape and Reel Packaging Specifications Brochure, BRD8011/D.

Resource Reference of Application Notes

- AN1405/D** – ECL Clock Distribution Techniques
- AN1406/D** – Designing with PECL (ECL at +5.0 V)
- AN1503/D** – ECLinPS™ I/O SPiCE Modeling Kit
- AN1504/D** – Metastability and the ECLinPS Family
- AN1568/D** – Interfacing Between LVDS and ECL
- AN1672/D** – The ECL Translator Guide
- AND8001/D** – Odd Number Counters Design
- AND8002/D** – Marking and Date Codes
- AND8020/D** – Termination of ECL Logic Devices
- AND8066/D** – Interfacing with ECLinPS
- AND8090/D** – AC Characteristics of ECL Devices

MECHANICAL CASE OUTLINE PACKAGE DIMENSIONS

ON Semiconductor®

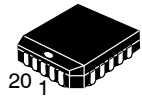

SCALE 1:1

20 LEAD PLCC CASE 775-02 ISSUE G

DATE 06 APR 2021

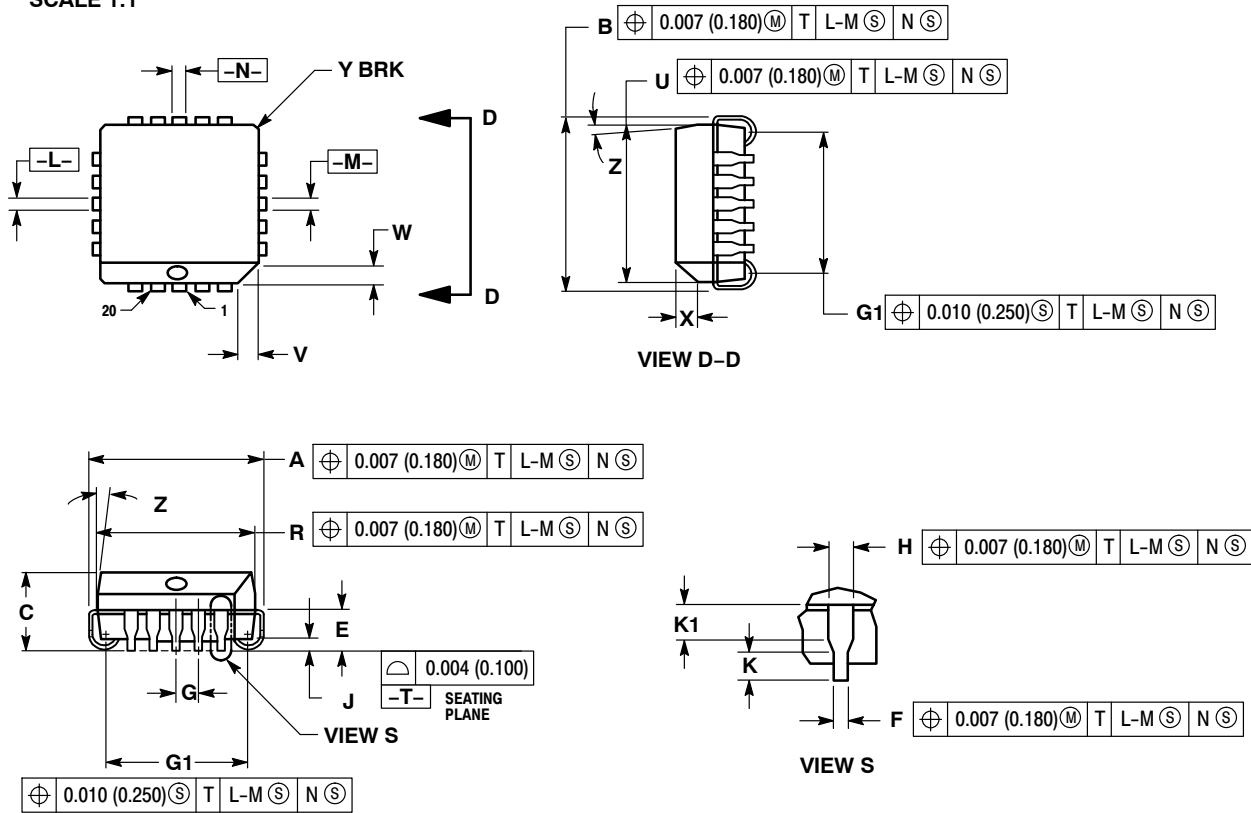

NOTES:

- DIMENSIONS AND TOLERANCING PER ANSI Y14.5M, 1982.
- DIMENSIONS IN INCHES.
- DATUMS -L-, -M-, AND -N- DETERMINED WHERE TOP OF LEAD SHOULDER EXITS PLASTIC BODY AT MOLD PARTING LINE.
- DIMENSION G1, TRUE POSITION TO BE MEASURED AT DATUM -T-, SEATING PLANE.
- DIMENSIONS R AND U DO NOT INCLUDE MOLD FLASH. ALLOWABLE MOLD FLASH IS 0.010 (0.250) PER SIDE.
- DIMENSIONS IN THE PACKAGE TOP MAY BE SMALLER THAN THE PACKAGE BOTTOM BY UP TO 0.012 (0.300). DIMENSIONS R AND U ARE DETERMINED AT THE OUTERMOST EXTREMES OF THE PLASTIC BODY EXCLUSIVE OF MOLD FLASH, TIE BAR BURRS, GATE BURRS AND INTERLEAD FLASH, BUT INCLUDING ANY MISMATCH BETWEEN THE TOP AND BOTTOM OF THE PLASTIC BODY.
- DIMENSION H DOES NOT INCLUDE DAMBAR PROTRUSION OR INTRUSION. THE DAMBAR PROTRUSION(S) SHALL NOT CAUSE THE H DIMENSION TO BE GREATER THAN 0.037 (0.940). THE DAMBAR INTRUSION(S) SHALL NOT CAUSE THE H DIMENSION TO BE SMALLER THAN 0.025 (0.635).

DIM	INCHES		MILLIMETERS	
	MIN	MAX	MIN	MAX
A	0.385	0.395	9.78	10.03
B	0.385	0.395	9.78	10.03
C	0.165	0.180	4.20	4.57
E	0.090	0.110	2.29	2.79
F	0.013	0.021	0.33	0.53
G	0.050 BSC		1.27 BSC	
H	0.026	0.032	0.66	0.81
J	0.020	---	0.51	---
K	0.025	---	0.64	---
R	0.350	0.356	8.89	9.04
U	0.350	0.356	8.89	9.04
V	0.042	0.048	1.07	1.21
W	0.042	0.048	1.07	1.21
X	0.042	0.056	1.07	1.42
Y	---	0.020	---	0.50
Z	2°	10°	2°	10°
G1	0.310	0.330	7.88	8.38
K1	0.040	---	1.02	---

GENERIC MARKING DIAGRAM*

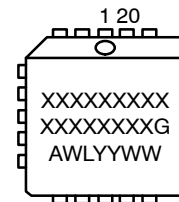

- XXXXXX = Specific Device Code
- A = Assembly Location
- WL = Wafer Lot
- YY = Year
- WW = Work Week
- G = Pb-Free Package

*This information is generic. Please refer to device data sheet for actual part marking. Pb-Free indicator, "G" or microdot "▪", may or may not be present.

DOCUMENT NUMBER:	98ASB42594B	Electronic versions are uncontrolled except when accessed directly from the Document Repository. Printed versions are uncontrolled except when stamped "CONTROLLED COPY" in red.
DESCRIPTION:	20 LEAD PLCC	PAGE 1 OF 1

ON Semiconductor and ON are trademarks of Semiconductor Components Industries, LLC dba ON Semiconductor or its subsidiaries in the United States and/or other countries. ON Semiconductor reserves the right to make changes without further notice to any products herein. ON Semiconductor makes no warranty, representation or guarantee regarding the suitability of its products for any particular purpose, nor does ON Semiconductor assume any liability arising out of the application or use of any product or circuit, and specifically disclaims any and all liability, including without limitation special, consequential or incidental damages. ON Semiconductor does not convey any license under its patent rights nor the rights of others.

onsemi, **Onsemi**, and other names, marks, and brands are registered and/or common law trademarks of Semiconductor Components Industries, LLC dba "**onsemi**" or its affiliates and/or subsidiaries in the United States and/or other countries. **onsemi** owns the rights to a number of patents, trademarks, copyrights, trade secrets, and other intellectual property. A listing of **onsemi**'s product/patent coverage may be accessed at www.onsemi.com/site/pdf/Patent-Marking.pdf. **onsemi** reserves the right to make changes at any time to any products or information herein, without notice. The information herein is provided "as-is" and **onsemi** makes no warranty, representation or guarantee regarding the accuracy of the information, product features, availability, functionality, or suitability of its products for any particular purpose, nor does **onsemi** assume any liability arising out of the application or use of any product or circuit, and specifically disclaims any and all liability, including without limitation special, consequential or incidental damages. Buyer is responsible for its products and applications using **onsemi** products, including compliance with all laws, regulations and safety requirements or standards, regardless of any support or applications information provided by **onsemi**. "Typical" parameters which may be provided in **onsemi** data sheets and/or specifications can and do vary in different applications and actual performance may vary over time. All operating parameters, including "Typicals" must be validated for each customer application by customer's technical experts. **onsemi** does not convey any license under any of its intellectual property rights nor the rights of others. **onsemi** products are not designed, intended, or authorized for use as a critical component in life support systems or any FDA Class 3 medical devices or medical devices with a same or similar classification in a foreign jurisdiction or any devices intended for implantation in the human body. Should Buyer purchase or use **onsemi** products for any such unintended or unauthorized application, Buyer shall indemnify and hold **onsemi** and its officers, employees, subsidiaries, affiliates, and distributors harmless against all claims, costs, damages, and expenses, and reasonable attorney fees arising out of, directly or indirectly, any claim of personal injury or death associated with such unintended or unauthorized use, even if such claim alleges that **onsemi** was negligent regarding the design or manufacture of the part. **onsemi** is an Equal Opportunity/Affirmative Action Employer. This literature is subject to all applicable copyright laws and is not for resale in any manner.

PUBLICATION ORDERING INFORMATION

LITERATURE FULFILLMENT:

Email Requests to: orderlit@onsemi.com

onsemi Website: www.onsemi.com

TECHNICAL SUPPORT

North American Technical Support:

Voice Mail: 1 800-282-9855 Toll Free USA/Canada

Phone: 011 421 33 790 2910

Europe, Middle East and Africa Technical Support:

Phone: 00421 33 790 2910

For additional information, please contact your local Sales Representative