

# ON Semiconductor

## Is Now

The logo for onsemi, featuring the word "onsemi" in a dark teal, lowercase, sans-serif font. The letter "i" is stylized with a white dot and a teal vertical bar. A small orange triangle is positioned above the top right of the "i". A trademark symbol (TM) is located to the right of the logo.

To learn more about onsemi™, please visit our website at  
[www.onsemi.com](http://www.onsemi.com)

---

**onsemi** and **onsemi** and other names, marks, and brands are registered and/or common law trademarks of Semiconductor Components Industries, LLC dba "**onsemi**" or its affiliates and/or subsidiaries in the United States and/or other countries. **onsemi** owns the rights to a number of patents, trademarks, copyrights, trade secrets, and other intellectual property. A listing of **onsemi** product/patent coverage may be accessed at [www.onsemi.com/site/pdf/Patent-Marking.pdf](http://www.onsemi.com/site/pdf/Patent-Marking.pdf). **onsemi** reserves the right to make changes at any time to any products or information herein, without notice. The information herein is provided "as-is" and **onsemi** makes no warranty, representation or guarantee regarding the accuracy of the information, product features, availability, functionality, or suitability of its products for any particular purpose, nor does **onsemi** assume any liability arising out of the application or use of any product or circuit, and specifically disclaims any and all liability, including without limitation special, consequential or incidental damages. Buyer is responsible for its products and applications using **onsemi** products, including compliance with all laws, regulations and safety requirements or standards, regardless of any support or applications information provided by **onsemi**. "Typical" parameters which may be provided in **onsemi** data sheets and/or specifications can and do vary in different applications and actual performance may vary over time. All operating parameters, including "Typicals" must be validated for each customer application by customer's technical experts. **onsemi** does not convey any license under any of its intellectual property rights nor the rights of others. **onsemi** products are not designed, intended, or authorized for use as a critical component in life support systems or any FDA Class 3 medical devices or medical devices with a same or similar classification in a foreign jurisdiction or any devices intended for implantation in the human body. Should Buyer purchase or use **onsemi** products for any such unintended or unauthorized application, Buyer shall indemnify and hold **onsemi** and its officers, employees, subsidiaries, affiliates, and distributors harmless against all claims, costs, damages, and expenses, and reasonable attorney fees arising out of, directly or indirectly, any claim of personal injury or death associated with such unintended or unauthorized use, even if such claim alleges that **onsemi** was negligent regarding the design or manufacture of the part. **onsemi** is an Equal Opportunity/Affirmative Action Employer. This literature is subject to all applicable copyright laws and is not for resale in any manner. Other names and brands may be claimed as the property of others.

# NCT22, NCT24

## Low Cost Single Trip Point Temperature Sensor

The NCT22 and NCT24 are programmable solid state temperature sensors designed to replace mechanical switches in sensing and control applications. Both devices integrate the temperature sensor with a voltage reference and all required detector circuitry. The desired temperature set point is set by the user with a single external resistor.

Ambient temperature is sensed and compared to the programmed setpoint. The OUT and  $\overline{\text{OUT}}$  outputs are driven to their active state when the measured temperature exceeds the programmed setpoint.

The NCT22 has a power supply voltage range of 4.5 V to 18 V while the NCT24 operates over a power supply range of 2.7 V to 4.5 V. Both devices are useable over a temperature range of  $-40^{\circ}\text{C}$  to  $+125^{\circ}\text{C}$ . Both devices feature low supply current making them suitable for many portable applications.

The devices are offered in surface mount packages.

### Features

- Temperature Set Point Easily Programs with a Single External Resistor
- Operates with 2.7 V Power Supply (NCT24)
- Small SOIC Package
- Cost Effective

### Applications

- Power Supply Over-Temperature Detection
- Consumer Electronics
- Fire/Heat Detection
- UPSs, Amplifiers, Motors
- CPU Thermal Management in PCs

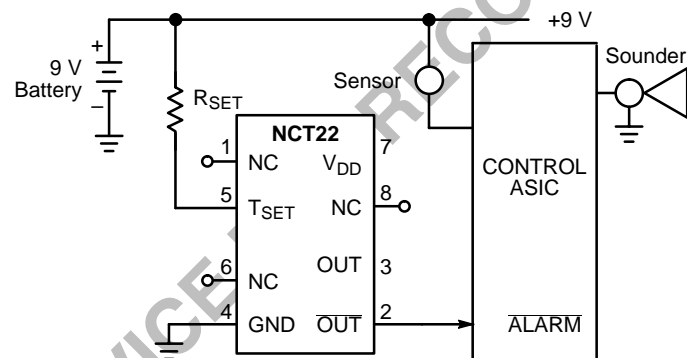

Figure 1. Heat Monitor for Smoke Detector



ON Semiconductor®

<http://onsemi.com>

### MARKING DIAGRAM

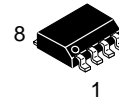

SOIC-8  
D SUFFIX  
CASE 751

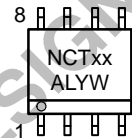

xx = 22 or 24  
A = Assembly Location  
L = Wafer Lot  
Y = Year  
W = Work Week

### PIN CONNECTIONS

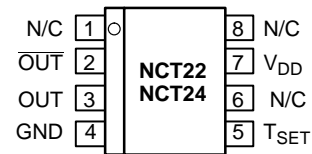

(Top View)

### ORDERING INFORMATION

See detailed ordering and shipping information in the package dimensions section on page 5 of this data sheet.

# NCT22, NCT24

## MAXIMUM RATINGS\*

Rating	Symbol	Value	Unit
Supply Voltage NCT22 NCT24	$V_{CC}$	20 5.5	V
Input Voltage (Any Input)	–	GND –0.3 to $V_{DD} + 0.3$	V
Operating Temperature Range	–	–40 to +125	°C
Maximum Junction Temperature	–	+150	°C
Storage Temperature Range	$T_{stg}$	–65 to +150	°C
Lead Temperature (Soldering, 10 seconds)	–	+300	°C

\*Stresses above those listed under “Absolute Maximum Ratings” may cause permanent damage to the device. These are stress ratings only and functional operation of the device at these or any other conditions above those indicated in the operational sections of the specifications is not implied. Exposure to Absolute Maximum Rating Conditions for extended periods may affect device reliability.

## ELECTRICAL CHARACTERISTICS (Over Operating Temperature Range, unless otherwise specified)

Characteristics	Device	Test Conditions	Min	Typ	Max	Unit
Supply Voltage Range	NCT22 NCT24	–	4.5 2.7	– –	18 4.5	V
Supply Current	NCT22 NCT24	$5.0\text{ V} \leq V_{DD} \leq 18\text{ V}$ $2.7\text{ V} \leq V_{DD} \leq 4.5\text{ V}$	– –	200 170	600 300	$\mu\text{A}$
$V_{OH}$	NCT22	$5.0\text{ V} \leq V_{DD} \leq 18\text{ V}$ $-40^\circ\text{C} \leq T_A \leq +125^\circ\text{C}$ $I_{OH} = 250\ \mu\text{A}$ $I_{OH} = 500\ \mu\text{A}$	$0.9 \times V_{DD}$ $0.8 \times V_{DD}$	– –	– –	V
$V_{OL}$	NCT22	$-40^\circ\text{C} \leq T_A \leq +85^\circ\text{C}$ $I_{OL} = 500\ \mu\text{A}$ $I_{OL} = 1.0\ \text{mA}$ $-40^\circ\text{C} \leq T_A \leq +125^\circ\text{C}$ $I_{OL} = 1.0\ \text{mA}$	– – –	– – –	$0.15 \times V_{DD}$ $0.30 \times V_{DD}$ $0.35 \times V_{DD}$	V
$V_{OH}$	NCT24	$2.7\text{ V} \leq V_{DD} \leq 4.5\text{ V}$ $-40^\circ\text{C} \leq T_A \leq +125^\circ\text{C}$ $I_{OH} = 250\ \mu\text{A}$ $I_{OH} = 500\ \mu\text{A}$	$0.9 \times V_{DD}$ $0.8 \times V_{DD}$	– –	– –	V
$V_{OL}$	NCT24	$-40^\circ\text{C} \leq T_A \leq +85^\circ\text{C}$ $I_{OL} = 500\ \mu\text{A}$ $I_{OL} = 1.0\ \text{mA}$ $-40^\circ\text{C} \leq T_A \leq +125^\circ\text{C}$ $I_{OL} = 1.0\ \text{mA}$	– – –	– – –	$0.1 \times V_{DD}$ $0.2 \times V_{DD}$ $0.25 \times V_{DD}$	V
Absolute Accuracy	NCT22 NCT24	$T_{SET} = \text{Programmed Temperature}$ $T_{SET} = \text{Programmed Temperature}$	T–5 T–5	$T \pm 1$ $T \pm 1$	T+5 T+5	°C
Trip Point Hysteresis	NCT22 NCT24	–	– –	2.0 2.0	– –	°C

**DETAILED DESCRIPTION**

**Trip Point Programming**

The NCT22 and NCT24 are single point temperature detectors ideal for use in a wide variety of applications. When the temperature of the device exceeds the programmed temperature trip point,  $T_{SET}$ , the  $\overline{OUT}$  and  $\overline{OUT}$  outputs are driven into their active states. The desired trip point temperature is programmed with a single external resistor connected between the  $T_{SET}$  input and  $V_{CC}$ . The relationship between the resistor value and the trip point temperature is given by the equation below.

$$R_{TRIP} = 0.5997 \times T^{2.1312}$$

Where  $R_{trip}$  = Programming resistor value in Ohms

$T$  = Desired trip temperature in degrees Kelvin.

For example, to program the device to trip at 50°C, the programming resistor is:

$$R_{TRIP} = 0.5997 \times ((50 + 273.15)^{2.1312}) = 133,652 \Omega$$

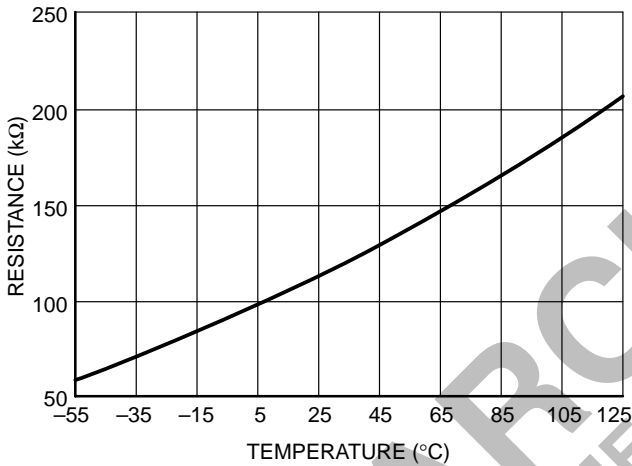
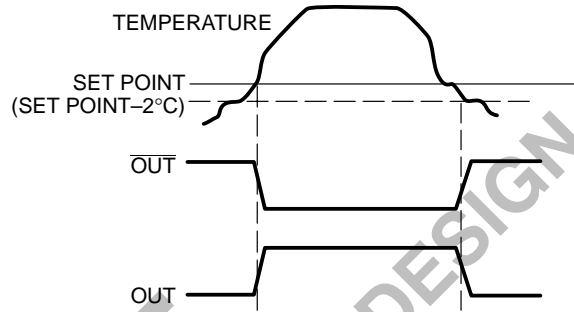

**Figure 2. Programming Resistor Values vs. Temperature**

**Hysteresis**

To prevent output “chattering” at the trip point temperature, the temperature detector in the NCT22/24 has 2°C of hysteresis (see Figure 3).

The outputs are driven active when the temperature crosses the setpoint determined by the external resistor. As temperature declines below the setpoint, the hysteresis action will hold the outputs true until the temperature drops 2°C below the threshold.



**Figure 3. NCT22/24 Hysteresis**

**APPLICATIONS**

**Over-Temperature Shutdown**

The NCT22 can be used to create a simple over-temperature shutdown circuit. In this circuit, temperature is sensed within the system enclosure (internal system ambient), or at the heatsink itself. When measured temperature exceeds a preset limit, a fault is indicated and the system shuts down.

Figure 4 illustrates a simple over-temperature shutdown circuit using the NCT22 sensor. As shown, the NCT22 outputs are driven active when the heatsink temperature equals the trip point temperature set by  $R_{SET}$ . When this happens, the crowbar circuit is activated, causing the supply output to fold back to zero. The NCT22 outputs remain active until the heatsink temperature falls a minimum of 2°C (built-in hysteresis) below the trip point temperature, at which time the device again allows normal supply operation.

# NCT22, NCT24

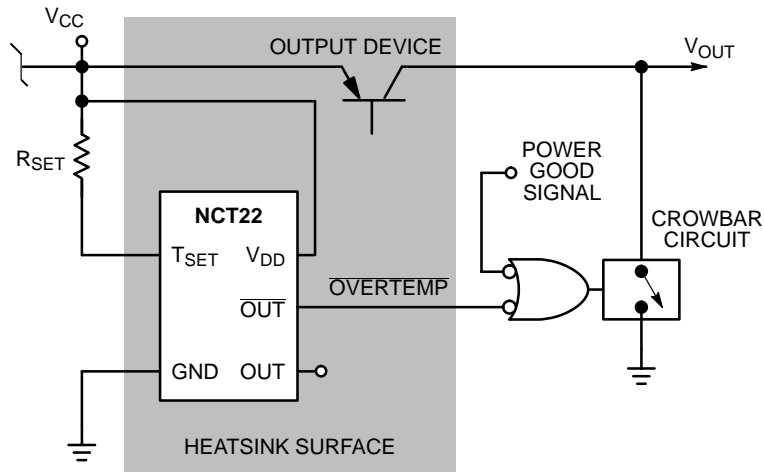

Figure 4. NCT22 Power Supply Over-Temperature Shutdown

## Cooling and Heating Applications

The NCT22/24 can be used to control a DC fan as shown in Figure 5. The fan turns on when the sensed temperature rises above  $T_{SET}$  and remains on until the temperature falls below  $T_{SET} - 2^{\circ}C$ .

Figure 6 shows the NCT22 acting as a heater thermostat. Circuit operation is identical to that of the cooling fan application.

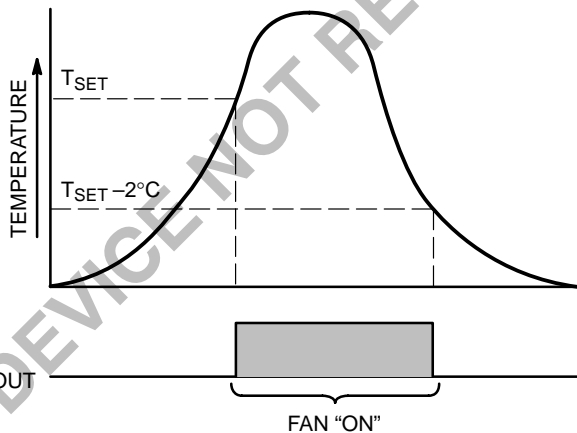
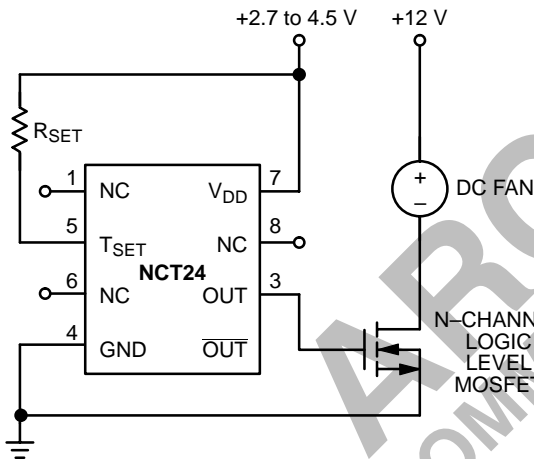

Figure 5. NCT24 As a Fan Controller for Notebook PCs

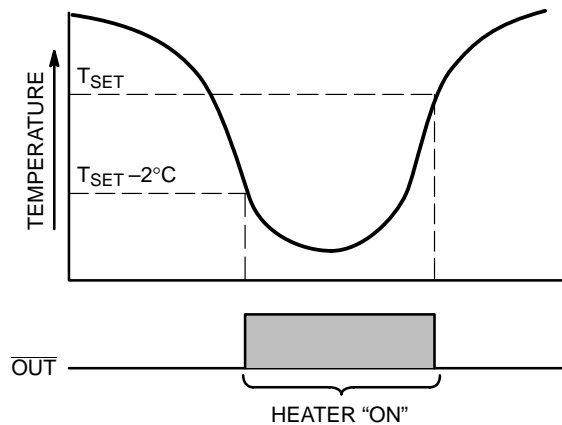
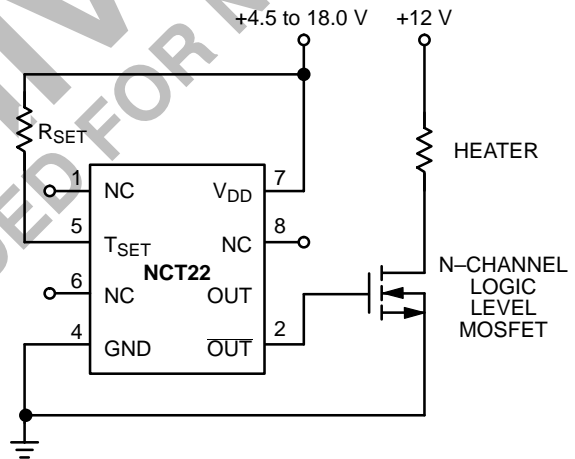

Figure 6. NCT22 As a Heater Thermostat

# NCT22, NCT24

## ORDERING INFORMATION

Device	Voltage Operation	Package	Ambient Temperature	Shipping
NCT22DR2	4.5 V to 18 V	SOIC-8	-40°C to +125°C	2500 Units Tape and Reel
NCT24DR2	2.7 V to 4.5 V	SOIC-8	-40°C to +125°C	2500 Units Tape and Reel

**ARCHIVE**  
DEVICE NOT RECOMMENDED FOR NEW DESIGN

**Notes**

ARCHIVE  
DEVICE NOT RECOMMENDED FOR NEW DESIGN

# NCT22, NCT24

## PACKAGE DIMENSIONS

SO-8  
D SUFFIX  
CASE 751-07  
ISSUE V

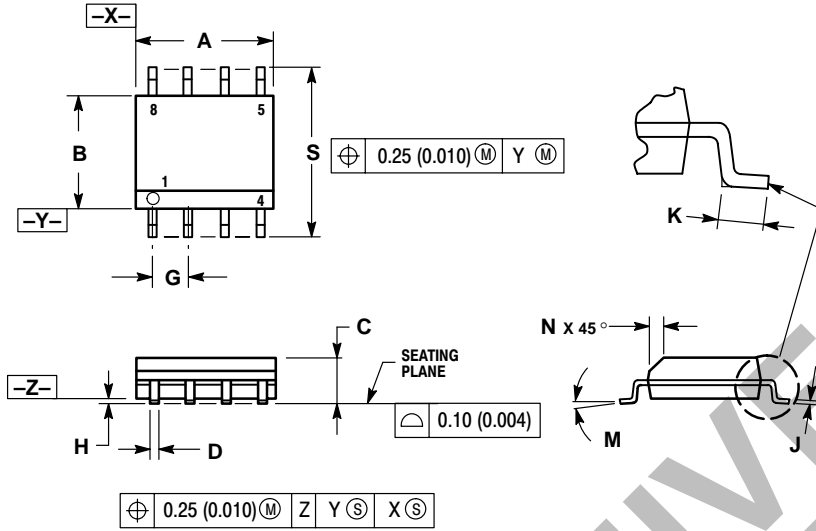

- NOTES:
1. DIMENSIONING AND TOLERANCING PER ANSI Y14.5M, 1982.
  2. CONTROLLING DIMENSION: MILLIMETER.
  3. DIMENSION A AND B DO NOT INCLUDE MOLD PROTRUSION.
  4. MAXIMUM MOLD PROTRUSION 0.15 (0.006) PER SIDE.
  5. DIMENSION D DOES NOT INCLUDE DAMBAR PROTRUSION. ALLOWABLE DAMBAR PROTRUSION SHALL BE 0.127 (0.005) TOTAL IN EXCESS OF THE D DIMENSION AT MAXIMUM MATERIAL CONDITION.

DIM	MILLIMETERS		INCHES	
	MIN	MAX	MIN	MAX
A	4.80	5.00	0.189	0.197
B	3.80	4.00	0.150	0.157
C	1.35	1.75	0.053	0.069
D	0.33	0.51	0.013	0.020
G	1.27 BSC		0.050 BSC	
H	0.10	0.25	0.004	0.010
J	0.19	0.25	0.007	0.010
K	0.40	1.27	0.016	0.050
M	0°	8°	0°	8°
N	0.25	0.50	0.010	0.020
S	5.80	6.20	0.228	0.244

ARCHIVED FOR REFERENCE  
DEVICE NOT RECOMMENDED FOR NEW DESIGN



ARCHIVE  
RECOMMENDED FOR NEW DESIGN

**ON Semiconductor** and  are registered trademarks of Semiconductor Components Industries, LLC (SCILLC). SCILLC reserves the right to make changes without further notice to any products herein. SCILLC makes no warranty, representation or guarantee regarding the suitability of its products for any particular purpose, nor does SCILLC assume any liability arising out of the application or use of any product or circuit, and specifically disclaims any and all liability, including without limitation special, consequential or incidental damages. "Typical" parameters which may be provided in SCILLC data sheets and/or specifications can and do vary in different applications and actual performance may vary over time. All operating parameters, including "Typicals" must be validated for each customer application by customer's technical experts. SCILLC does not convey any license under its patent rights nor the rights of others. SCILLC products are not designed, intended, or authorized for use as components in systems intended for surgical implant into the body, or other applications intended to support or sustain life, or for any other application in which the failure of the SCILLC product could create a situation where personal injury or death may occur. Should Buyer purchase or use SCILLC products for any such unintended or unauthorized application, Buyer shall indemnify and hold SCILLC and its officers, employees, subsidiaries, affiliates, and distributors harmless against all claims, costs, damages, and expenses, and reasonable attorney fees arising out of, directly or indirectly, any claim of personal injury or death associated with such unintended or unauthorized use, even if such claim alleges that SCILLC was negligent regarding the design or manufacture of the part. SCILLC is an Equal Opportunity/Affirmative Action Employer.

## PUBLICATION ORDERING INFORMATION

### Literature Fulfillment:

Literature Distribution Center for ON Semiconductor  
P.O. Box 5163, Denver, Colorado 80217 USA  
**Phone:** 303-675-2175 or 800-344-3860 Toll Free USA/Canada  
**Fax:** 303-675-2176 or 800-344-3867 Toll Free USA/Canada  
**Email:** ONlit@hibbertco.com

**N. American Technical Support:** 800-282-9855 Toll Free USA/Canada

**JAPAN:** ON Semiconductor, Japan Customer Focus Center  
4-32-1 Nishi-Gotanda, Shinagawa-ku, Tokyo, Japan 141-0031  
**Phone:** 81-3-5740-2700  
**Email:** r14525@onsemi.com

**ON Semiconductor Website:** <http://onsemi.com>

For additional information, please contact your local Sales Representative.