

# NIS5020, NIS5021, NIS5820

## +12 Volt Electronic Fuse

The NIS5x2x Series eFuse is a cost effective, resettable fuse which can greatly enhance the reliability of a hard drive or other circuit from both catastrophic and shutdown failures.

It is designed to buffer the load device from excessive input voltage which can damage sensitive circuits. It includes an overvoltage clamp circuit that limits the output voltage during transients but does not shut the unit down, thereby allowing the load circuit to continue its operation.

### Features

- 14 mΩ and 24 mΩ Typical  $R_{DS(on)}$  Options
- Tristate Enable
- Overcurrent Protection
- Thermally Protected
- Integrated Soft–Start Circuit
- Fast Response Overvoltage Clamp Circuit
- Internal Undervoltage Lockout Circuit
- Internal Charge Pump
- NIS5020 and NIS5820 in WDFN10 3x3
- NIS5021 in WDFN10 4x4
- Hot Pluggable
- ESD HBM Rating: 1.5 kV
- ESD CDM Rating: 1.0 kV
- These Devices are Pb–Free, Halogen Free/BFR Free and are RoHS Compliant

### Typical Applications

- Hard Drives
- Solid State Drives
- Servers
- Mother Boards
- Fan Drives



**ON Semiconductor®**

[www.onsemi.com](http://www.onsemi.com)

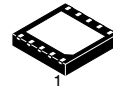

WDFN10 4x4  
CASE 511DS



WDFN10 3x3  
CASE 522AA

### MARKING DIAGRAM

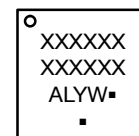

- XXXX = Specific Device Code  
(See ORDERING INFORMATION table below)
- A = Assembly Location  
L = Wafer Lot  
Y = Year  
W = Work Week  
▪ = Pb–Free Package

(Note: Microdot may be in either location)

### PIN CONNECTIONS

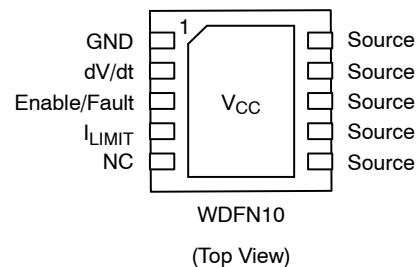

### ORDERING INFORMATION

See detailed ordering and shipping information on page 11 of this data sheet.

# NIS5020, NIS5021, NIS5820

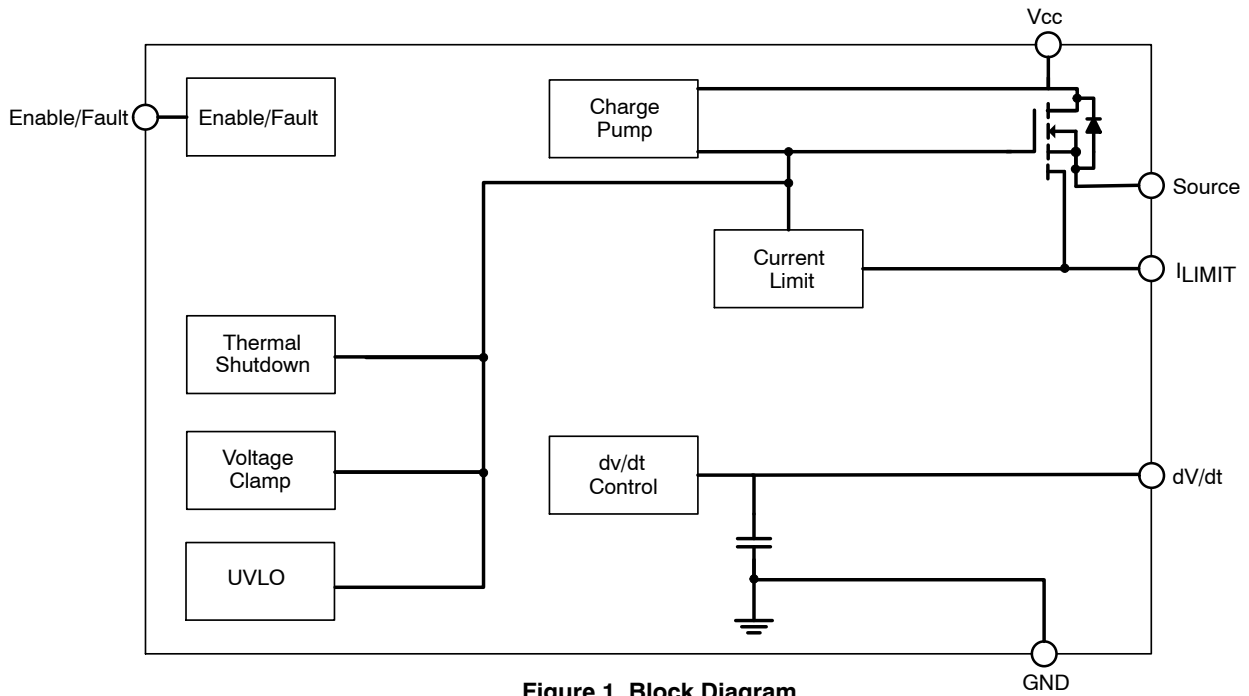

Figure 1. Block Diagram

## NIS5020, NIS5021, NIS5820

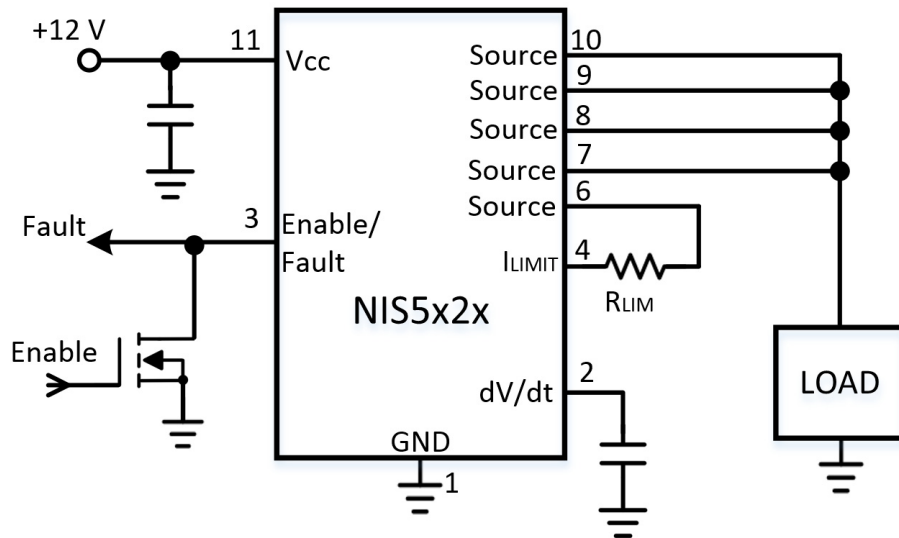

Figure 2. Application Circuit with Kelvin Current Sensing

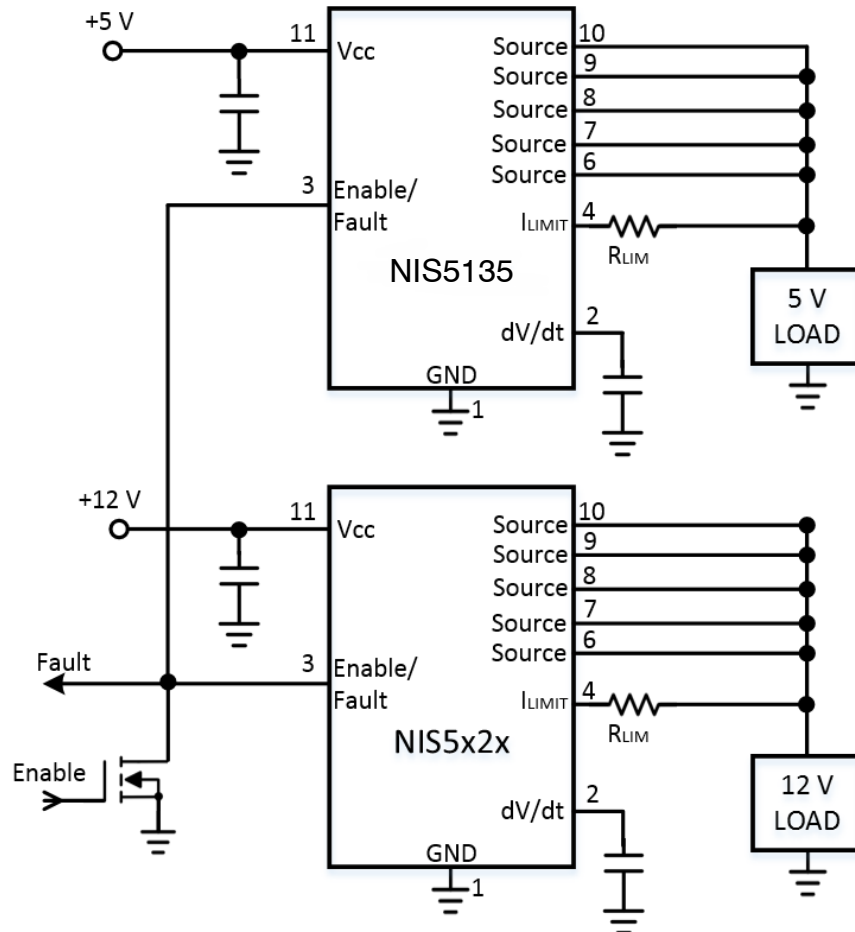

Figure 3. Common Thermal Shutdown between 12 V and 5 V Family Devices

# NIS5020, NIS5021, NIS5820

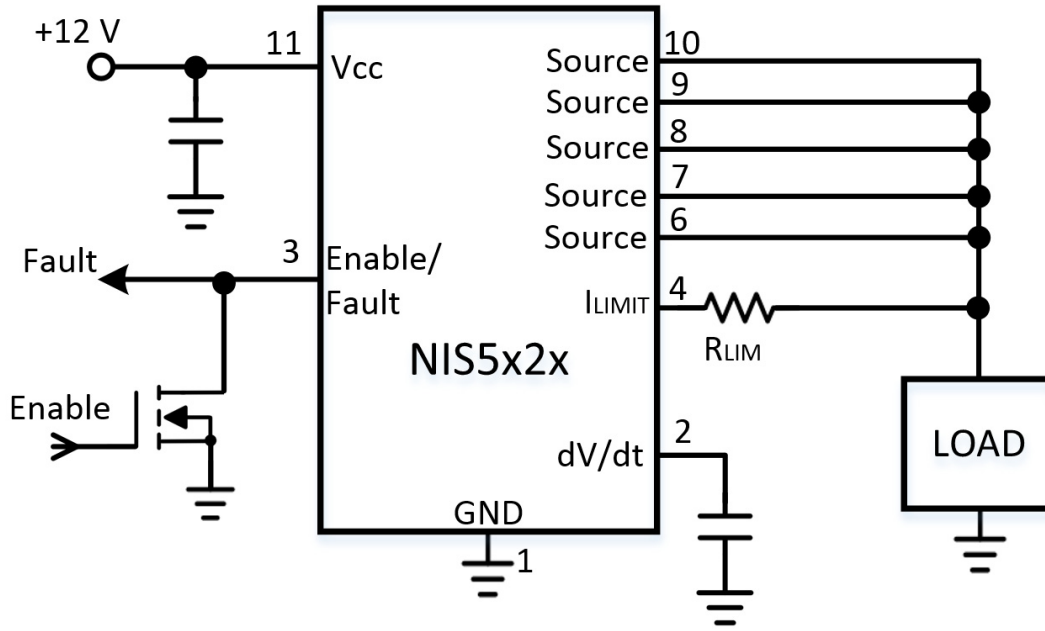

Figure 4. Application Circuit with Direct Current Sensing

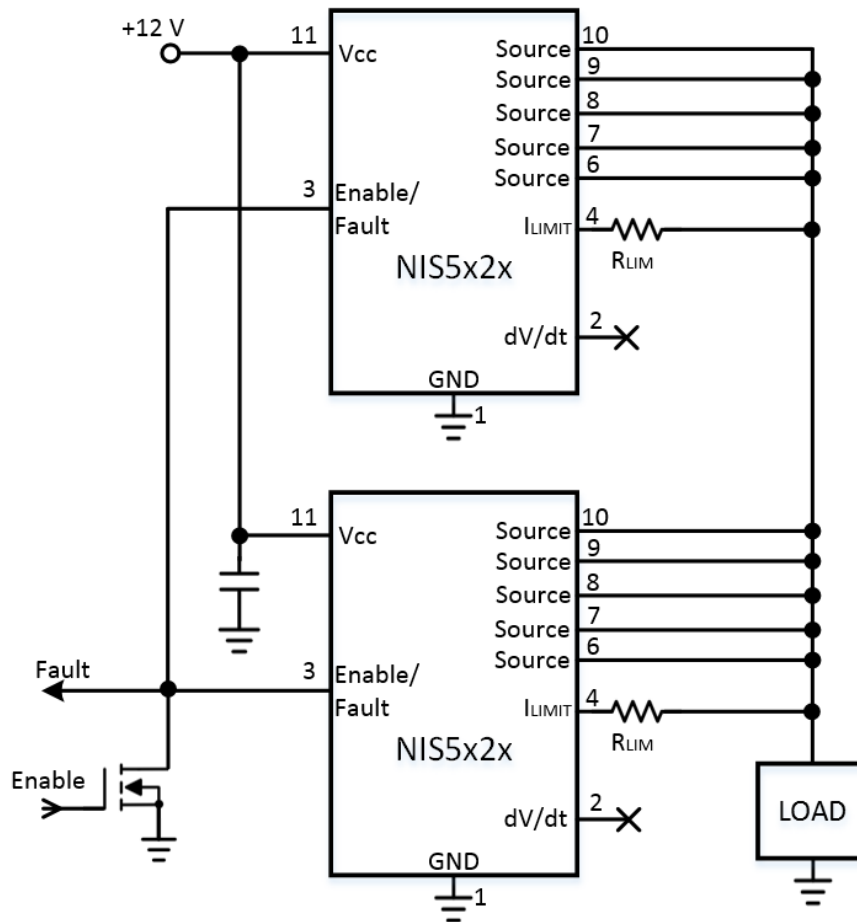

Figure 5. Paralleling eFuses

## NIS5020, NIS5021, NIS5820

### PIN FUNCTION DESCRIPTION

Pin No. DFN10	Pin Name	Description
1	GND	Negative input voltage to the device. This is used as the internal reference for the IC.
2	dV/dt	The internal dv/dt circuit controls the slew rate of the output voltage at turn on. It has an internal capacitor that allows it to ramp up over a period of 1 ms. An external capacitor can be added to this pin to increase the ramp time. If an additional time delay is not required, this pin should be left open.
3	Enable/ Fault	The enable/fault pin is a tri-state, bidirectional interface. It can be pulled to ground with an external open-drain or open collector device to shut down the eFuse. It can also be used as a status indicator; if the voltage level is intermediate (around 1.4V), the eFuse is in thermal shutdown. If the voltage level is high (around 3V) the eFuse is operating normally. Do not actively drive this pin to any voltage. Do not connect a capacitor to this pin.
4	I <sub>LIMIT</sub>	A resistor between this pin and the source pin sets the overload and short circuit current limit levels
5	NC	No Connect. Leave this pin unconnected.
6–10	Source	Source of the internal power FET and the output terminal of the fuse
11 (Pad)	V <sub>CC</sub>	Positive input voltage to the device. Connect a 1.0 μF or greater capacitor from V <sub>CC</sub> to GND as close as possible to the IC.

### MAXIMUM RATINGS

Rating	Symbol	Value	Unit
Input Voltage, operating, steady-state (V <sub>CC</sub> to GND)	V <sub>CC</sub>	-0.3 to +18	V
Transient (100 ms) (Note 1)		-0.3 to +20	

Stresses exceeding those listed in the Maximum Ratings table may damage the device. If any of these limits are exceeded, device functionality should not be assumed, damage may occur and reliability may be affected.

1. Guaranteed by characterization only.

# NIS5020, NIS5021, NIS5820

## THEMAL RATINGS

Rating	Symbol	Value	Unit
Thermal Resistance, Junction-to-Air, NIS5020 (4 layer High-K JEDEC JESD51-7 PCB, 100 mm <sup>2</sup> , 2 oz. Cu)	$\theta_{JA}$	50	°C/W
Thermal Resistance, Junction-to-Air, NIS5021 (4 layer High-K JEDEC JESD51-7 PCB, 100 mm <sup>2</sup> , 2 oz. Cu)		40	
Thermal Characterization Parameter, Junction-to-Top (4 layer High-K JEDEC JESD51-7 PCB, 100 mm <sup>2</sup> , 2 oz. Cu)	$\Psi_{J-T}$	2.6	°C/W
Thermal Characterization Parameter, Junction-to-Board (4 layer High-K JEDEC JESD51-7 PCB, 100 mm <sup>2</sup> , 2 oz. Cu)	$\Psi_{J-B}$	11.7	°C/W
Total Continuous Power Dissipation, NIS5020 @ T <sub>A</sub> = 25°C (4 layer High-K JEDEC JESD51-7 PCB, 100 mm <sup>2</sup> , 2 oz. Cu) Derate above 25°C	P <sub>max</sub>	2.5 20	W mW/°C
Total Continuous Power Dissipation, NIS5021 @ T <sub>A</sub> = 25°C (4 layer High-K JEDEC JESD51-7 PCB, 100 mm <sup>2</sup> , 2 oz. Cu) Derate above 25°C	P <sub>max</sub>	3.1 25	W mW/°C
Operating Temperature Range	T <sub>J</sub>	-40 to 150	°C
Non-operating Temperature Range	T <sub>J</sub>	-55 to 150	°C
Lead Temperature, Soldering (10 Sec)	T <sub>L</sub>	260	°C

## ELECTRICAL CHARACTERISTICS (Unless otherwise noted: V<sub>CC</sub> = 12 V, C<sub>L</sub> = 20 μF, dV/dt pin open, R<sub>LIM</sub> = 75 Ω, T<sub>A</sub> = 25°C)

Characteristics	Symbol	Min	Typ	Max	Unit
-----------------	--------	-----	-----	-----	------

### POWER FET

Delay Time (enabling of chip to V <sub>OUT</sub> rising to 10% of V <sub>CC</sub> = 12 V, C <sub>OUT</sub> = 0 μF)		T <sub>DLY</sub>		200		μs
ON Resistance (Note 4)	NIS5020	R <sub>DSON</sub>	11	14	18	mΩ
	NIS5021		11	14	18	
	NIS5820		19	24	30	
ON Resistance T <sub>J</sub> = 140°C (Note 5)	NIS5020	R <sub>DSON@140C</sub>		22		mΩ
	NIS5021			22		
	NIS5820			37		
Continuous Current (T <sub>A</sub> = 25°C), 100 mm <sup>2</sup> 1 oz. Cu per layer, one layer (Note 5)	NIS5020	I <sub>D</sub>		6.6		A
	NIS5021			6.9		
	NIS5820			5.0		
Continuous Current (T <sub>A</sub> = 25°C), 4 layer PCB High-K JEDEC JESD51-7, >800 mm <sup>2</sup> , 2 oz. Cu (Note 5)	NIS5020	I <sub>D</sub>		10		A
	NIS5021			11		
	NIS5820			8.0		
Continuous Current (T <sub>A</sub> = 25°C), 12 layer PCB, 2 oz. Cu, 15000 mm <sup>2</sup> (per layer)	NIS5021	I <sub>D</sub>		12		A
Off State Leakage (V <sub>in</sub> = 12 V, EN = 0)		I <sub>OFF</sub>			1	μA

### THERMAL LATCH

Shutdown Temperature (Notes 2, 5)	T <sub>SD</sub>	150	175	200	°C
Thermal Hysteresis (Decrease in die temperature for turn on, does not apply to latching parts)	T <sub>HYST</sub>		45		°C

Product parametric performance is indicated in the Electrical Characteristics for the listed test conditions, unless otherwise noted. Product performance may not be indicated by the Electrical Characteristics if operated under different conditions.

2. eFuse is latched off until the En/Fault pin is pulled low and then released or a power on reset is applied to the device.
3. Does not include fan out of Enable/Fault function.
4. Pulse test: Pulse width 300 s, duty cycle 2%
5. Verified by design.

# NIS5020, NIS5021, NIS5820

**ELECTRICAL CHARACTERISTICS** (Unless otherwise noted:  $V_{CC} = 12\text{ V}$ ,  $C_L = 20\ \mu\text{F}$ ,  $dV/dt$  pin open,  $R_{LIM} = 75\ \Omega$ ,  $T_A = 25^\circ\text{C}$ )

Characteristics	Symbol	Min	Typ	Max	Unit
-----------------	--------	-----	-----	-----	------

## UNDER/OVERVOLTAGE PROTECTION

$V_{OUT}$ Maximum ( $V_{CC} = 18\text{ V}$ )	$V_{out-clamp}$	13	14	15	V
Undervoltage Lockout (Turn on, Voltage Going High)	$V_{UVLO}$	7.8	8.5	9.2	V
UVLO Hysteresis	$V_{Hyst}$		0.8		V

## KELVIN CURRENT LIMIT

Overload/Trip Current, $R_{lim} = 75\ \Omega$	NIS5020/ NIS5021	$I_{TRIP}$		7.6		A
Short Circuit/Holding Current $R_{lim} = 75\ \Omega$		$I_{HOLD}$	1.8	3.4	5.0	A
Overload/Trip Current, $R_{lim} = 75\ \Omega$	NIS5820	$I_{TRIP}$		5.3		A
Short Circuit/Holding Current $R_{lim} = 75\ \Omega$		$I_{HOLD}$	1.3	2.0	2.7	A

## SLEW RATE CONTROL

Slew Rate (no capacitor on $dV/dt$ pin)	SR	0.7	1.0	1.9	ms
---	----	-----	-----	-----	----

## ENABLE/FAULT

Logic Level Low (Output Disabled)	$V_{in-low}$	0.35	0.58	0.81	V
Logic Level Mid (Thermal Fault, Output Disabled)	$V_{in-mid}$	0.82	1.4	1.95	V
Logic Level High (Output Enabled)	$V_{in-high}$	1.96	2.2	2.5	V
High State Maximum Voltage	$V_{in-max}$	2.51	3.3	5.0	V
Logic Low Sink Current ( $V_{ENABLE} = 0\text{ V}$ )	$I_{in-low}$		-17	-25	$\mu\text{A}$
Logic High Leakage Current for External Switch ( $V_{ENABLE} = 3.3\text{ V}$ )	$I_{in-leak}$			1.0	$\mu\text{A}$
Maximum Fanout for Fault Signal (Total number of chips that can be connected to this pin for simultaneous shutdown)	Fan			3.0	Units

## TOTAL DEVICE

Bias Current	$I_{Bias}$		650	800	$\mu\text{A}$
Operational ( $I_{Load} = 0\text{ A}$ )					
Shutdown ( $EN = 0$ ) (Note 3)			100	150	
Fault			110	200	

Product parametric performance is indicated in the Electrical Characteristics for the listed test conditions, unless otherwise noted. Product performance may not be indicated by the Electrical Characteristics if operated under different conditions.

- eFuse is latched off until the  $EN/Fault$  pin is pulled low and then released or a power on reset is applied to the device.
- Does not include fan out of Enable/Fault function.
- Pulse test: Pulse width 300 s, duty cycle 2%
- Verified by design.

TYPICAL CHARACTERISTICS

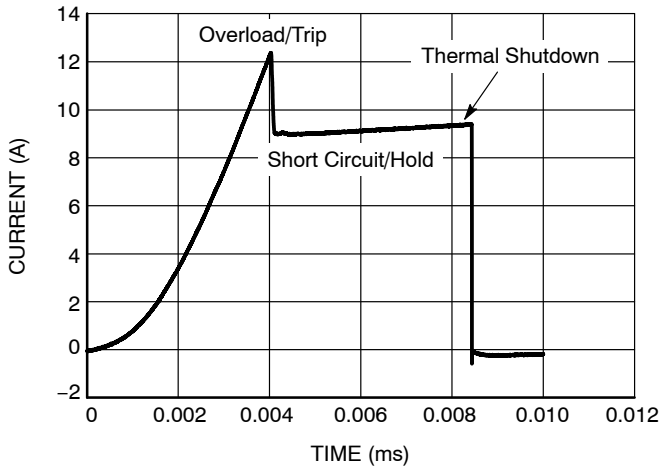

Figure 6. Slow Fault Current Limit Characteristic of NIS5020

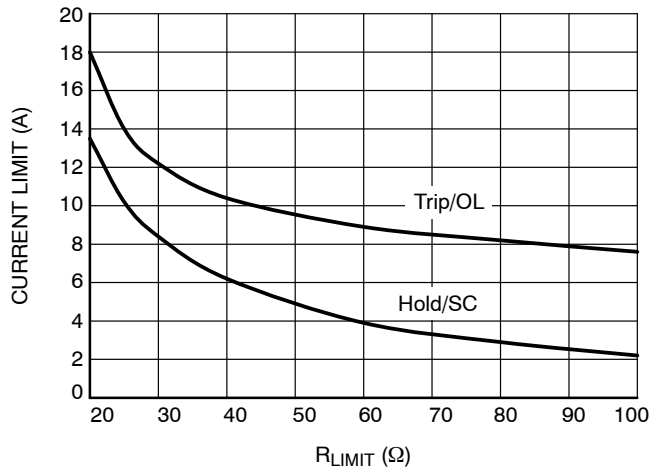

Figure 7. NIS5020/NIS5021 Current Limit vs.  $R_{LIMIT}$  for Kelvin Sensing

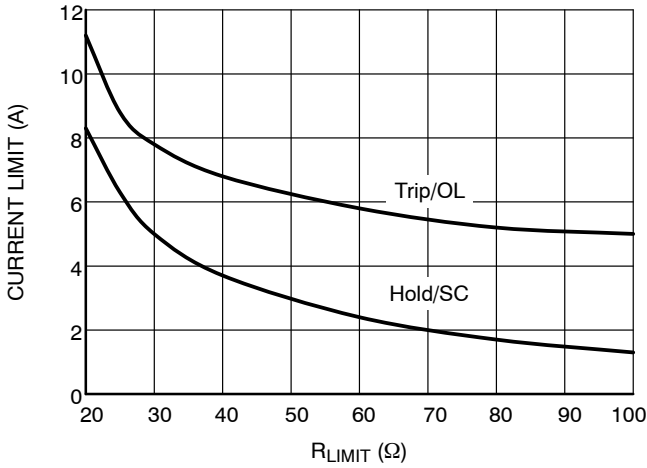

Figure 8. NIS5820 Current Limit vs.  $R_{LIMIT}$  for Kelvin Sensing

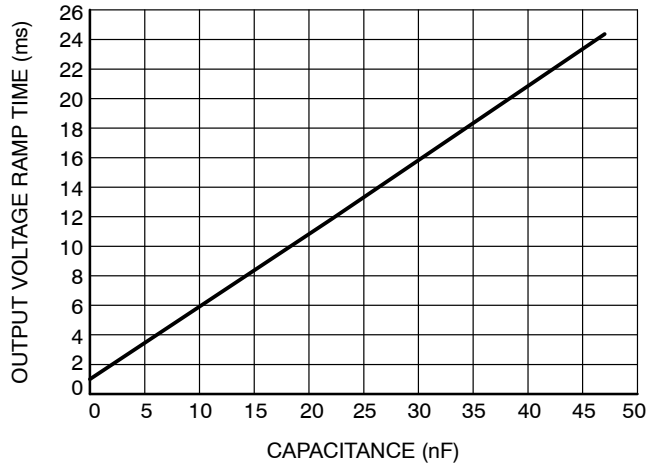

Figure 9. Output Voltage Ramp Time vs.  $dv/dt$  Capacitance



# NIS5020, NIS5021, NIS5820

## TYPICAL CHARACTERISTICS

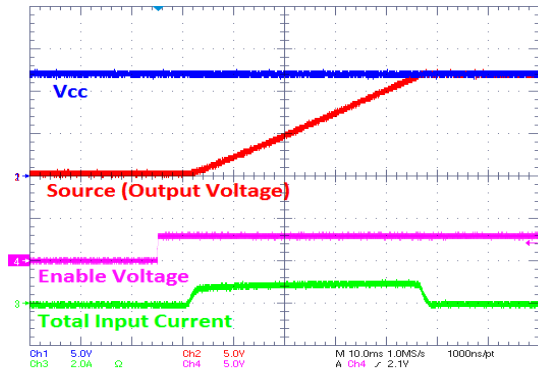

Figure 10. NIS5020 Slew Rate Control

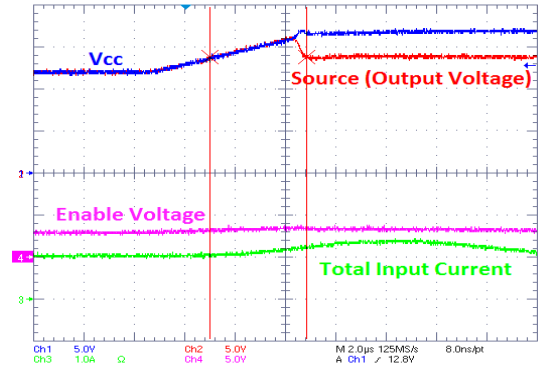

Figure 11. NIS5020 Overvoltage Clamp Operation

## APPLICATIONS INFORMATION

**Paralleling eFuses**

If the output current capability required by an application is higher than the current which can be carried by a single eFuse, it is possible to parallel eFuses to achieve a higher current throughput. Up to four eFuses can be paralleled to achieve a higher current. All of the eFuses will have a common thermal shutdown. Refer to Figure 5 for the schematic connection of parallel eFuses. The VCC pins of every eFuse must be shorted together. The Source pins of each eFuse must be shorted together. Each eFuse should be configured either in Kelvin or Direct mode and have its individual current limiting resistor  $R_{lim}$  connected between  $I_{LIMIT}$  and Source pins. The Enable pins of all the eFuses must be shorted together for common shutdown functionality and connected to an open-drain or open collector device in case it is desired to turn off all the eFuses at the same time. The dv/dt pins of eFuses must NOT be shorted together; they should be either left floating for a standard output ramp-up time or have individual dvdt capacitor to ground.

Every eFuse will carry equal amount of current during normal operation and overcurrent events. If any of the eFuses goes to thermal shutdown first, it will pull down the Enable pin and make the other eFuses to shut down as well.

**Basic Operation**

This device is a self-protected, resettable, electronic fuse. It contains circuits to monitor the input voltage, output voltage, output current and die temperature.

On application of the input voltage, the device will apply the input voltage to the load based on the restrictions of the controlling circuits. The output voltage, which is controlled by an internal dV/dt circuit, will slew from 0 V to the rated output voltage in 1 ms. The device will remain on as long as the temperature does not exceed the 175°C limit that is programmed into the chip.

The internal current limit circuit does not shut down the part but will reduce the conductivity of the FET to maintain a constant current at the internally set current limit level. The input overvoltage clamp also does not shutdown the part, but will limit the output voltage in the event that the input exceeds the  $V_{clamp}$  level.

An internal charge pump provides bias for the gate voltage of the internal n-channel power FET and also for the current limit circuit. The remainder of the control circuitry operates between the input voltage ( $V_{CC}$ ) and ground.

**Current Limit**

The current limit circuit uses a SENSEFET along with a reference and amplifier to control the peak current in the device. The SENSEFET allows for a small fraction of the load current to be measured, which has the advantage of reducing the losses in the sense resistor.

The current limit circuit has two limiting values, one for short circuit events which are defined as the mode of

operation in which the gate is high and the FET is fully enhanced. The overload mode of operation occurs when the device is actively limiting the current and the gate is at an intermediate level. For a more detailed description of this circuit please refer to application note AND9441.

Connection of  $R_{LIMIT}$  current limit setting resistor can be made as shown in Figure 2 (Kelvin connection), or Figure 4 (Direct connection). Both connections result in a similar current limit thresholds and behavior. It is important to make sure that layout trace connecting  $R_{LIMIT}$  resistor to pins 4 and 6 is as short as possible. The shortest possible distance on a PCB must be used to connect pin 6 to  $R_{LIM}$  resistor before pin 6 is connected to a common load node.

**Overvoltage Clamp**

The overvoltage clamp consists of an amplifier and reference. It monitors the output voltage and if the input voltage exceeds 14 V, the gate drive of the main FET is reduced to limit the output. This is intended to allow operation through transients while protecting the load. If an overvoltage condition exists for many seconds, the device may overheat due to the voltage drop across the FET combined with the load current. In this event, the thermal protection circuit would shut down the device. Refer to Figure 12 for typical overvoltage clamp behavior

**Undervoltage Lockout**

The undervoltage lockout circuit uses a comparator with hysteresis to monitor the input voltage. If the input voltage drops below the specified level, the output switch will be switched to a high impedance state.

**Slew Rate Control**

The dV/dt circuit brings the output voltage up under a linear, controlled rate regardless of the load impedance characteristics. An internal ramp generator creates a linear ramp, and a control circuit forces the output voltage to follow that ramp, scaled by a factor.

The default ramp time is approximately 1 ms. This pin includes an internal current source of approximately 1  $\mu$ A. Since the current level is very low, it is important to use a ceramic cap or other low leakage capacitor. Aluminum electrolytic capacitors are not recommended for this circuit. The ramp time from 10% to 90% of the nominal output voltage can be determined by the following equation:

$$C_{ext} = \left( \frac{t}{0.5E06} \right) - 1.4 \text{ nF}$$

Where: C is in Farads,  
t is in Seconds

Anytime that the unit shuts down due to a fault, enable shut-down, or recycling of input power, the timing capacitor will be discharged and the output voltage will ramp from 0 at turn on. Refer to Figures 9 and 11 for slew rate control and typical Slew Rate behavior.

## NIS5020, NIS5021, NIS5820

### Enable/Fault

The Enable/Fault Pin is a multi-function, bidirectional pin that can control the output of the chip as well as send information to other devices regarding the state of the chip. When this pin is low, the output of the fuse will be turned off. When this pin is high the output of the fuse will be turned-on. If a thermal fault occurs, this pin will be pulled low to an intermediate level by an internal circuit. To use as a simple enable pin, an open drain or open collector device should be connected to this pin. Due to its tri-state operation, it should not be connected to any type of logic with an internal pull-up device. Do not connect external capacitor directly to this pin.

If the chip shuts down due to the die temperature reaching its thermal limit, this pin will be pulled down to an intermediate level. This signal can be monitored by an external circuit to communicate that a thermal shutdown has occurred. If this pin is tied to another device in this family, a thermal shutdown of one device will cause both devices to disable their outputs. Both devices will turn on once the fault is removed for the auto-retry devices.

Since this is a latching thermal device, the outputs will be enabled after the enable pin has been pulled to ground with an external switch and then allowed to go high or after the input power has been recycled.

### Thermal Protection

The NIS5x2x Series includes an internal temperature sensing circuit that senses the temperature on the die of the power FET. If the temperature reaches 175°C, the device will shut down, and remove power from the load. Output power can be restored by either recycling the input power or toggling the enable pin. Power will automatically be reapplied to the load for auto-retry devices once the die temperature has been reduced by 45°C.

The thermal limit has been set high intentionally, to increase the trip time during high power transient events. It is not recommended to operate this device above 150°C for extended periods of time.

The similar devices from different voltage families can be configured together as shown in Figure 3 for a common thermal shutdown.

### ORDERING INFORMATION

Device	Marking	Features	Package	Shipping†
NIS5020MT1TXG	5020	Latch	WDFN10-3x3	3000 / Tape & Reel
NIS5020MT2TXG	5020A	Auto-Retry	WDFN10-3x3	3000 / Tape & Reel
NIS5021MT1TXG	5021	Latch	WDFN10-4x4	3000 / Tape & Reel
NIS5021MT2TXG	5021A	Auto-Retry	WDFN10-4x4	3000 / Tape & Reel
NIS5820MT1TXG	5820	Latch	WDFN10-3x3	3000 / Tape & Reel
NIS5820MT2TXG	5820A	Auto-Retry	WDFN10-3x3	3000 / Tape & Reel

†For information on tape and reel specifications, including part orientation and tape sizes, please refer to our Tape and Reel Packaging Specifications Brochure, BRD8011/D.

# MECHANICAL CASE OUTLINE

## PACKAGE DIMENSIONS

ON Semiconductor®

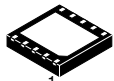

SCALE 2:1

### WDFN10 4x4, 0.8P CASE 511DS ISSUE A

DATE 23 MAY 2017

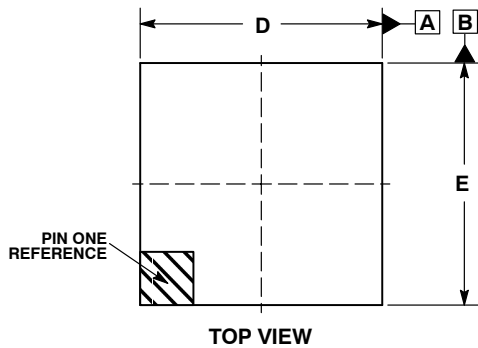

TOP VIEW

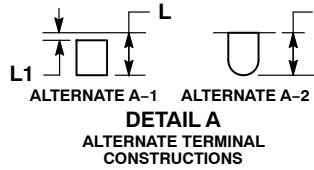

DETAIL A  
ALTERNATE TERMINAL  
CONSTRUCTIONS

NOTES:

1. DIMENSIONING AND TOLERANCING PER ASME Y14.5M, 1994.
2. CONTROLLING DIMENSION: MILLIMETERS.
3. DIMENSION b APPLIES TO PLATED TERMINAL AND IS MEASURED BETWEEN 0.20 AND 0.25 MM FROM THE TERMINAL TIP.
4. COPLANARITY APPLIES TO THE EXPOSED PAD AS WELL AS THE TERMINALS.
5. FOR DEVICE OPN CONTAINING W OPTION, DETAIL B ALTERNATE B-1 AND DETAIL A ALTERNATE A-1 CONSTRUCTIONS ARE NOT APPLICABLE.

MILLIMETERS			
DIM	MIN	NOM	MAX
A	0.70	0.75	0.80
A1	0.00	0.03	0.05
A3	0.20 REF		
b	0.25	0.30	0.35
D	3.90	4.00	4.10
D2	3.30	3.40	3.50
E	3.90	4.00	4.10
E2	2.69	2.79	2.89
e	0.80 BSC		
K	0.20 REF		
L	0.30	0.40	0.50
L1	0.00	0.05	0.10

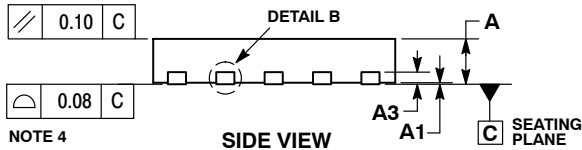

SIDE VIEW

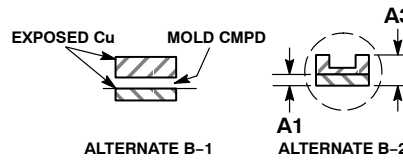

DETAIL B  
ALTERNATE  
CONSTRUCTIONS

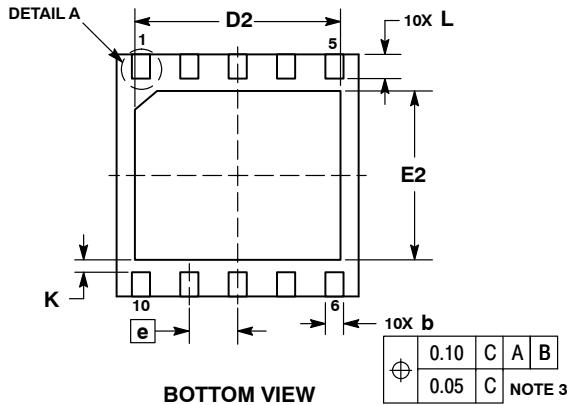

BOTTOM VIEW

### GENERIC MARKING DIAGRAM\*

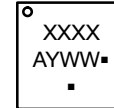

- XXXX = Specific Device Code
- A = Assembly Location
- Y = Year
- WW = Work Week
- = Pb-Free Package

(Note: Microdot may be in either location)

\*This information is generic. Please refer to device data sheet for actual part marking. Pb-Free indicator, "G", may or not be present. Some products may not follow the Generic Marking.

### RECOMMENDED MOUNTING FOOTPRINT

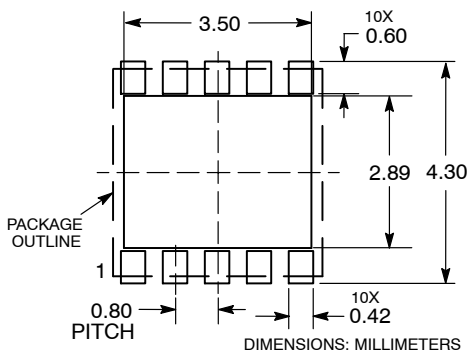

<b>DOCUMENT NUMBER:</b>	<b>98AON15519G</b>	Electronic versions are uncontrolled except when accessed directly from the Document Repository. Printed versions are uncontrolled except when stamped "CONTROLLED COPY" in red.
<b>DESCRIPTION:</b>	<b>WDFN10 4X4, 0.8P</b>	<b>PAGE 1 OF 1</b>

ON Semiconductor and are trademarks of Semiconductor Components Industries, LLC dba ON Semiconductor or its subsidiaries in the United States and/or other countries. ON Semiconductor reserves the right to make changes without further notice to any products herein. ON Semiconductor makes no warranty, representation or guarantee regarding the suitability of its products for any particular purpose, nor does ON Semiconductor assume any liability arising out of the application or use of any product or circuit, and specifically disclaims any and all liability, including without limitation special, consequential or incidental damages. ON Semiconductor does not convey any license under its patent rights nor the rights of others.

# MECHANICAL CASE OUTLINE

## PACKAGE DIMENSIONS

ON Semiconductor®



**WDFN10, 3x3, 0.5P**  
CASE 522AA-01  
ISSUE A

SCALE 2:1

DATE 02 JUL 2007

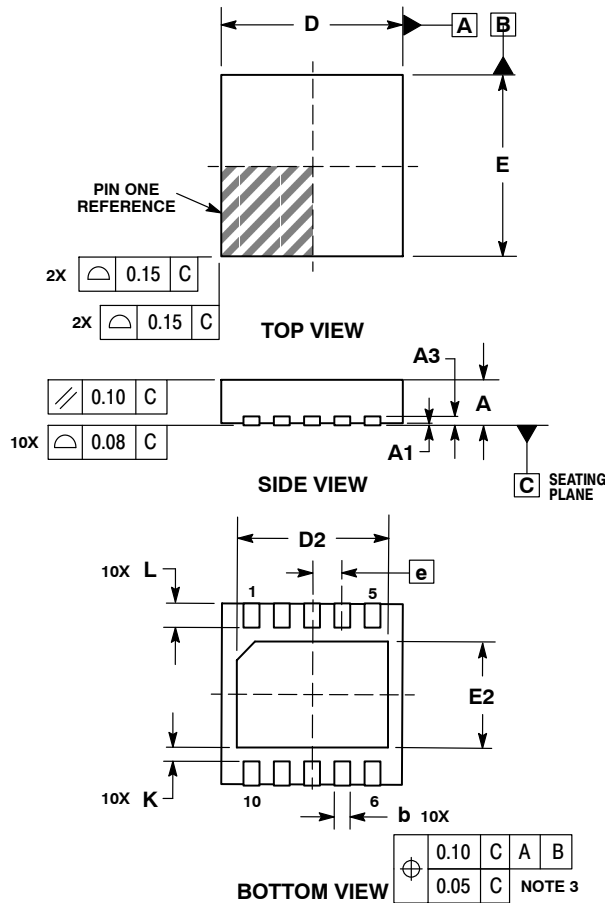

**NOTES:**

1. DIMENSIONING AND TOLERANCING PER ASME Y14.5M, 1994.
2. CONTROLLING DIMENSION: MILLIMETERS.
3. DIMENSION b APPLIES TO PLATED TERMINAL AND IS MEASURED BETWEEN 0.15 AND 0.30mm FROM TERMINAL.
4. COPLANARITY APPLIES TO THE EXPOSED PAD AS WELL AS THE TERMINALS.

DIM	MILLIMETERS		
	MIN	NOM	MAX
A	0.70	0.75	0.80
A1	0.00	0.03	0.05
A3	0.20 REF		
b	0.18	0.24	0.30
D	3.00 BSC		
D2	2.45	2.50	2.55
E	3.00 BSC		
E2	1.75	1.80	1.85
e	0.50 BSC		
K	0.19 TYP		
L	0.35	0.40	0.45

**GENERIC MARKING DIAGRAM\***

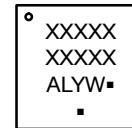

- A = Assembly Location
  - L = Wafer Lot
  - Y = Year
  - W = Work Week
  - = Pb-Free Package
- (Note: Microdot may be in either location)

\*This information is generic. Please refer to device data sheet for actual part marking. Pb-Free indicator, "G" or microdot "▪", may or may not be present.

**SOLDERING FOOTPRINT\***

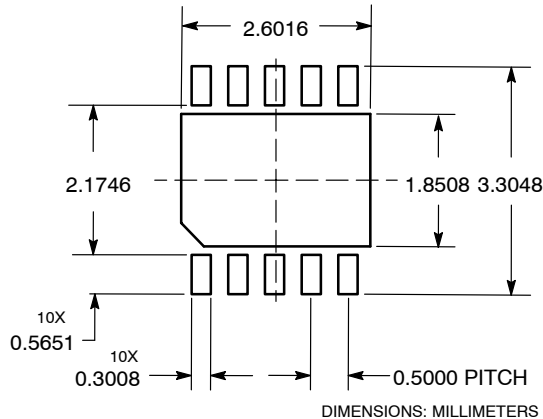

\*For additional information on our Pb-Free strategy and soldering details, please download the ON Semiconductor Soldering and Mounting Techniques Reference Manual, SOLDERRM/D.

<b>DOCUMENT NUMBER:</b>	<b>98AON22331D</b>	Electronic versions are uncontrolled except when accessed directly from the Document Repository. Printed versions are uncontrolled except when stamped "CONTROLLED COPY" in red.
<b>DESCRIPTION:</b>	<b>WDFN10 3X3, 0.5P</b>	<b>PAGE 1 OF 1</b>

ON Semiconductor and ON are trademarks of Semiconductor Components Industries, LLC dba ON Semiconductor or its subsidiaries in the United States and/or other countries. ON Semiconductor reserves the right to make changes without further notice to any products herein. ON Semiconductor makes no warranty, representation or guarantee regarding the suitability of its products for any particular purpose, nor does ON Semiconductor assume any liability arising out of the application or use of any product or circuit, and specifically disclaims any and all liability, including without limitation special, consequential or incidental damages. ON Semiconductor does not convey any license under its patent rights nor the rights of others.

**onsemi**, **Onsemi**, and other names, marks, and brands are registered and/or common law trademarks of Semiconductor Components Industries, LLC dba "**onsemi**" or its affiliates and/or subsidiaries in the United States and/or other countries. **onsemi** owns the rights to a number of patents, trademarks, copyrights, trade secrets, and other intellectual property. A listing of **onsemi**'s product/patent coverage may be accessed at [www.onsemi.com/site/pdf/Patent-Marking.pdf](http://www.onsemi.com/site/pdf/Patent-Marking.pdf). **onsemi** reserves the right to make changes at any time to any products or information herein, without notice. The information herein is provided "as-is" and **onsemi** makes no warranty, representation or guarantee regarding the accuracy of the information, product features, availability, functionality, or suitability of its products for any particular purpose, nor does **onsemi** assume any liability arising out of the application or use of any product or circuit, and specifically disclaims any and all liability, including without limitation special, consequential or incidental damages. Buyer is responsible for its products and applications using **onsemi** products, including compliance with all laws, regulations and safety requirements or standards, regardless of any support or applications information provided by **onsemi**. "Typical" parameters which may be provided in **onsemi** data sheets and/or specifications can and do vary in different applications and actual performance may vary over time. All operating parameters, including "Typicals" must be validated for each customer application by customer's technical experts. **onsemi** does not convey any license under any of its intellectual property rights nor the rights of others. **onsemi** products are not designed, intended, or authorized for use as a critical component in life support systems or any FDA Class 3 medical devices or medical devices with a same or similar classification in a foreign jurisdiction or any devices intended for implantation in the human body. Should Buyer purchase or use **onsemi** products for any such unintended or unauthorized application, Buyer shall indemnify and hold **onsemi** and its officers, employees, subsidiaries, affiliates, and distributors harmless against all claims, costs, damages, and expenses, and reasonable attorney fees arising out of, directly or indirectly, any claim of personal injury or death associated with such unintended or unauthorized use, even if such claim alleges that **onsemi** was negligent regarding the design or manufacture of the part. **onsemi** is an Equal Opportunity/Affirmative Action Employer. This literature is subject to all applicable copyright laws and is not for resale in any manner.

## PUBLICATION ORDERING INFORMATION

### LITERATURE FULFILLMENT:

Email Requests to: [orderlit@onsemi.com](mailto:orderlit@onsemi.com)

**onsemi Website:** [www.onsemi.com](http://www.onsemi.com)

### TECHNICAL SUPPORT

**North American Technical Support:**

Voice Mail: 1 800-282-9855 Toll Free USA/Canada

Phone: 011 421 33 790 2910

**Europe, Middle East and Africa Technical Support:**

Phone: 00421 33 790 2910

For additional information, please contact your local Sales Representative