

# ON Semiconductor

## Is Now

# onsemi™

To learn more about onsemi™, please visit our website at  
[www.onsemi.com](http://www.onsemi.com)

---

**onsemi** and **onsemi** and other names, marks, and brands are registered and/or common law trademarks of Semiconductor Components Industries, LLC dba "**onsemi**" or its affiliates and/or subsidiaries in the United States and/or other countries. **onsemi** owns the rights to a number of patents, trademarks, copyrights, trade secrets, and other intellectual property. A listing of **onsemi** product/patent coverage may be accessed at [www.onsemi.com/site/pdf/Patent-Marking.pdf](http://www.onsemi.com/site/pdf/Patent-Marking.pdf). **onsemi** reserves the right to make changes at any time to any products or information herein, without notice. The information herein is provided "as-is" and **onsemi** makes no warranty, representation or guarantee regarding the accuracy of the information, product features, availability, functionality, or suitability of its products for any particular purpose, nor does **onsemi** assume any liability arising out of the application or use of any product or circuit, and specifically disclaims any and all liability, including without limitation special, consequential or incidental damages. Buyer is responsible for its products and applications using **onsemi** products, including compliance with all laws, regulations and safety requirements or standards, regardless of any support or applications information provided by **onsemi**. "Typical" parameters which may be provided in **onsemi** data sheets and/or specifications can and do vary in different applications and actual performance may vary over time. All operating parameters, including "Typicals" must be validated for each customer application by customer's technical experts. **onsemi** does not convey any license under any of its intellectual property rights nor the rights of others. **onsemi** products are not designed, intended, or authorized for use as a critical component in life support systems or any FDA Class 3 medical devices or medical devices with a same or similar classification in a foreign jurisdiction or any devices intended for implantation in the human body. Should Buyer purchase or use **onsemi** products for any such unintended or unauthorized application, Buyer shall indemnify and hold **onsemi** and its officers, employees, subsidiaries, affiliates, and distributors harmless against all claims, costs, damages, and expenses, and reasonable attorney fees arising out of, directly or indirectly, any claim of personal injury or death associated with such unintended or unauthorized use, even if such claim alleges that **onsemi** was negligent regarding the design or manufacture of the part. **onsemi** is an Equal Opportunity/Affirmative Action Employer. This literature is subject to all applicable copyright laws and is not for resale in any manner. Other names and brands may be claimed as the property of others.

# CS5253-1

## 3.0 A LDO 5-Pin Adjustable Linear Regulator

This new very low dropout linear regulator reduces total power dissipation in the application. To achieve very low dropout, the internal pass transistor is powered separately from the control circuitry. Furthermore, with the control and power inputs tied together, this device can be used in single supply configuration and still offer a better dropout voltage than conventional PNP – NPN based LDO regulators. In this mode the dropout is determined by the minimum control voltage.

The CS5253-1 is offered in a five-terminal D<sup>2</sup>PAK-5 package, which allows for the implementation of a remote-sense pin permitting very accurate regulation of output voltage directly at the load, where it counts, rather than at the regulator. This remote sensing feature virtually eliminates output voltage variations due to load changes and resistive voltage drops. Typical load regulation measured at the sense pin is less than 1.0 mV for an output voltage of 2.5 V with a load step of 10 mA to 3.0 A.

The CS5253-1 has a very fast transient loop response which can be adjusted using a small capacitor on the Adjust pin.

Internal protection circuitry provides for “bust-proof” operation, similar to three-terminal regulators. This circuitry, which includes overcurrent, short circuit, and over-temperature protection will self protect the regulator under all fault conditions.

The CS5253-1 is ideal for generating a 2.5 V supply to power graphics controllers used on VGA cards.

### Features

- V<sub>OUT</sub> Range Is 1.25 V to 5.0 V @ 3.0 A
- V<sub>POWER</sub> Dropout < 0.40 V @ 3.0 A
- V<sub>CONTROL</sub> Dropout < 1.05 V @ 3.0 A
- 1.0% Trimmed Reference
- Fast Transient Response
- Remote Voltage Sensing
- Thermal Shutdown
- Current Limit
- Short Circuit Protection
- Drop-In Replacement for EZ1582
- Backwards Compatible with 3-Pin Regulators
- Very Low Dropout Reduces Total Power Consumption
- Pb-Free Package is Available\*

\*For additional information on our Pb-Free strategy and soldering details, please download the ON Semiconductor Soldering and Mounting Techniques Reference Manual, SOLDERRM/D.



ON Semiconductor®

<http://onsemi.com>

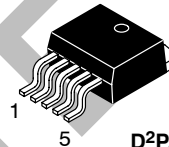

D<sup>2</sup>PAK-5  
DP SUFFIX  
CASE 936AC

Tab = V<sub>OUT</sub>  
Pin 1. V<sub>SENSE</sub>  
2. Adjust  
3. V<sub>OUT</sub>  
4. V<sub>CONTROL</sub>  
5. V<sub>POWER</sub>

### MARKING DIAGRAM



CS5253-1 = Device Code  
A = Assembly Location  
WL = Wafer Lot  
Y = Year  
WW = Work Week  
G = Pb-Free Package

### ORDERING INFORMATION

Device	Package	Shipping†
CS5253-1GDP5	D <sup>2</sup> PAK-5	50 Units/Rail
CS5253-1GDPR5	D <sup>2</sup> PAK-5	750/Tape & Reel
CS5253-1GDPR5G	D <sup>2</sup> PAK-5 (Pb-Free)	750/Tape & Reel

†For information on tape and reel specifications, including part orientation and tape sizes, please refer to our Tape and Reel Packaging Specifications Brochure, BRD8011/D.

## CS5253-1

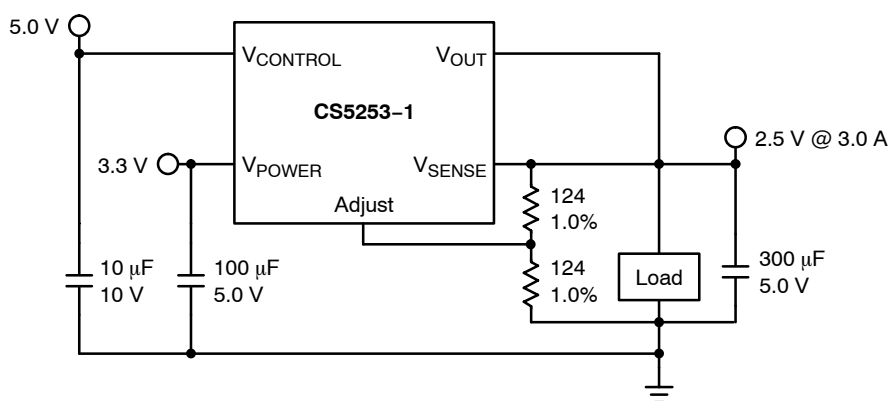

Figure 1. Application Diagram

### MAXIMUM RATINGS

Rating	Value	Unit
$V_{POWER}$ Input Voltage	6.0	V
$V_{CONTROL}$ Input Voltage	13	V
Operating Junction Temperature Range, $T_J$	0 to 150	°C
Storage Temperature Range	-65 to +150	°C
ESD Damage Threshold	2.0	kV
Lead Temperature Soldering:	Reflow: (SMD styles only) (Note 1)	230 peak

Stresses exceeding Maximum Ratings may damage the device. Maximum Ratings are stress ratings only. Functional operation above the Recommended Operating Conditions is not implied. Extended exposure to stresses above the Recommended Operating Conditions may affect device reliability.

- 60 second maximum above 183°C.

### ELECTRICAL CHARACTERISTICS ( $0^\circ\text{C} \leq T_A \leq 70^\circ\text{C}$ ; $0^\circ\text{C} \leq T_J \leq 150^\circ\text{C}$ ; $V_{SENSE} = V_{OUT}$ and $V_{ADJ} = 0\text{ V}$ ; unless otherwise specified.)

Characteristic	Test Conditions	Min	Typ	Max	Unit
<b>CS5253-1</b>					
Reference Voltage	$V_{CONTROL} = 2.75\text{ V to }12\text{ V}$ , $V_{POWER} = 2.05\text{ V to }5.5\text{ V}$ , $I_{OUT} = 10\text{ mA to }3.0\text{ A}$	1.237 (-1.0%)	1.250	1.263 (+1.0%)	V
Line Regulation	$V_{CONTROL} = 2.5\text{ V to }12\text{ V}$ , $V_{POWER} = 1.75\text{ V to }5.5\text{ V}$ , $I_{OUT} = 10\text{ mA}$	-	0.02	0.2	%
Load Regulation	$V_{CONTROL} = 2.75\text{ V}$ , $V_{POWER} = 2.05\text{ V}$ , $I_{OUT} = 10\text{ mA to }3.0\text{ A}$ , with Remote Sense	-	0.04	0.3	%
Minimum Load Current (Note 2)	$V_{CONTROL} = 5.0\text{ V}$ , $V_{POWER} = 3.3\text{ V}$ , $\Delta V_{OUT} = +1.0\%$	-	5.0	10	mA
Control Pin Current (Note 3)	$V_{CONTROL} = 2.75\text{ V}$ , $V_{POWER} = 2.05\text{ V}$ , $I_{OUT} = 100\text{ mA}$ $V_{CONTROL} = 2.75\text{ V}$ , $V_{POWER} = 2.05\text{ V}$ , $I_{OUT} = 3.0\text{ A}$	-	6.0 35	10 120	mA mA
Adjust Pin Current	$V_{CONTROL} = 2.75\text{ V}$ , $V_{POWER} = 2.05\text{ V}$ , $I_{OUT} = 10\text{ mA}$	-	60	120	µA
Current Limit	$V_{CONTROL} = 2.75\text{ V}$ , $V_{POWER} = 2.05\text{ V}$ , $\Delta V_{OUT} = -1.0\%$	3.1	4.0	-	A
Short Circuit Current	$V_{CONTROL} = 2.75\text{ V}$ , $V_{POWER} = 2.05\text{ V}$ , $V_{OUT} = 0\text{ V}$	2.0	3.5	-	A

- The minimum load current is the minimum current required to maintain regulation. Normally the current in the resistor divider used to set the output voltage is selected to meet the minimum load current requirement.
- The  $V_{CONTROL}$  pin current is the drive current required for the output transistor. This current will track output current with roughly a 1:100 ratio. The minimum value is equal to the quiescent current of the device.

# CS5253-1

## ELECTRICAL CHARACTERISTICS (0°C ≤ T<sub>A</sub> ≤ 70°C; 0°C ≤ T<sub>J</sub> ≤ 150°C; V<sub>SENSE</sub> = V<sub>OUT</sub> and V<sub>ADJ</sub> = 0 V; unless otherwise specified.)

Characteristic	Test Conditions	Min	Typ	Max	Unit
<b>CS5253-1</b>					
Ripple Rejection (Note 4)	V <sub>CONTROL</sub> = V <sub>POWER</sub> = 3.25 V, V <sub>RIPPLE</sub> = 1.0 V <sub>P-P</sub> @ 120 Hz, I <sub>OUT</sub> = 4.0 A, C <sub>ADJ</sub> = 0.1 μF	60	80	-	dB
Thermal Regulation	30 ms Pulse, T <sub>A</sub> = 25°C	-	0.002	-	%/W
V <sub>CONTROL</sub> Dropout Voltage (Minimum V <sub>CONTROL</sub> - V <sub>OUT</sub> ) (Note 5)	V <sub>POWER</sub> = 2.05 V, I <sub>OUT</sub> = 100 mA V <sub>POWER</sub> = 2.05 V, I <sub>OUT</sub> = 1.0 A V <sub>POWER</sub> = 2.05 V, I <sub>OUT</sub> = 3.0 A	-	0.90 1.00 1.05	1.15 1.15 1.30	V V V
V <sub>POWER</sub> Dropout Voltage (Minimum V <sub>POWER</sub> - V <sub>OUT</sub> ) (Note 5)	V <sub>CONTROL</sub> = 2.75 V, I <sub>OUT</sub> = 100 mA V <sub>CONTROL</sub> = 2.75 V, I <sub>OUT</sub> = 1.0 A V <sub>CONTROL</sub> = 2.75 V, I <sub>OUT</sub> = 3.0 A	-	0.05 0.15 0.40	0.15 0.25 0.60	V V V
RMS Output Noise	Freq = 10 Hz to 10 kHz, T <sub>A</sub> = 25°C	-	0.003	-	%V <sub>OUT</sub>
Temperature Stability	-	0.5	-	-	%
Thermal Shutdown (Note 6)	-	150	180	210	°C
Thermal Shutdown Hysteresis	-	-	25	-	°C
V <sub>CONTROL</sub> Supply Only Output Current	V <sub>CONTROL</sub> = 13 V, V <sub>POWER</sub> Not Connected, V <sub>ADJ</sub> = V <sub>OUT</sub> = V <sub>SENSE</sub> = 0 V	-	-	50	mA
V <sub>POWER</sub> Supply Only Output Current	V <sub>POWER</sub> = 6.0 V, V <sub>CONTROL</sub> Not Connected, V <sub>ADJ</sub> = V <sub>OUT</sub> = V <sub>SENSE</sub> = 0 V	-	0.1	1.0	mA

- This parameter is guaranteed by design and is not 100% production tested.
- Dropout is defined as either the minimum control voltage (V<sub>CONTROL</sub>) or minimum power voltage (V<sub>POWER</sub>) to output voltage differential required to maintain 1.0% regulation at a particular load current.
- This parameter is guaranteed by design, but not parametrically tested in production. However, a 100% thermal shutdown functional test is performed on each part.

## PACKAGE PIN DESCRIPTION

PIN #	PIN SYMBOL	FUNCTION
1	V <sub>SENSE</sub>	This Kelvin sense pin allows for remote sensing of the output voltage at the load for improved regulation. It is internally connected to the positive input of the voltage sensing error amplifier.
2	Adjust	This pin is connected to the low side of the internally trimmed 1.0% bandgap reference voltage and carries a bias current of about 50 μA. A resistor divider from Adjust to V <sub>OUT</sub> and from Adjust to ground sets the output voltage. Also, transient response can be improved by adding a small bypass capacitor from this pin to ground.
3	V <sub>OUT</sub>	This pin is connected to the emitter of the power pass transistor and provides a regulated voltage capable of sourcing 3.0 A of current.
4	V <sub>CONTROL</sub>	This is the supply voltage for the regulator control circuitry. For the device to regulate, this voltage should be between 0.9 V and 1.3 V (depending on the output current) greater than the output voltage. The control pin current will be about 1.0% of the output current.
5	V <sub>POWER</sub>	This is the power input voltage. This pin is physically connected to the collector of the power pass transistor. For the device to regulate, this voltage should be between 0.1 V and 0.6 V greater than the output voltage depending on the output current. The output load current of 3.0 A is supplied through this pin.

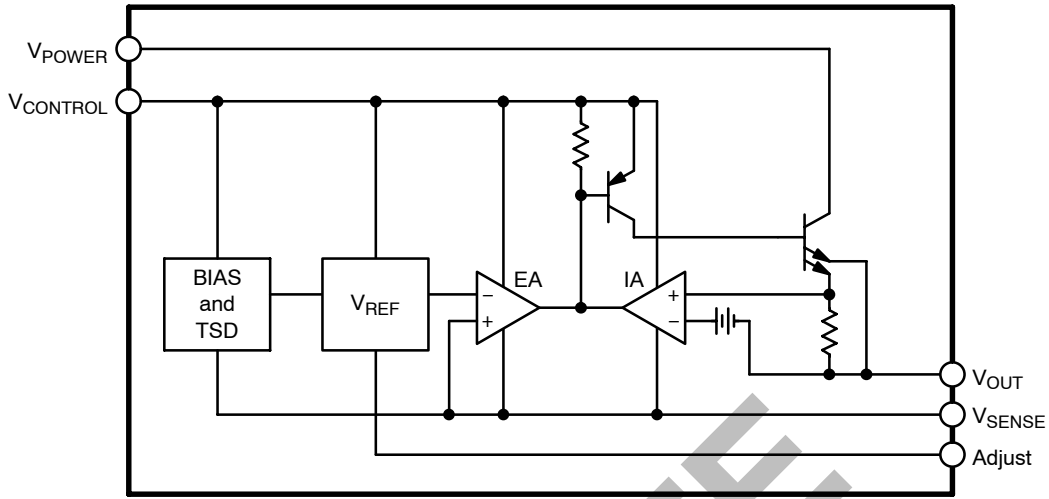

Figure 2. Block Diagram

TYPICAL PERFORMANCE CHARACTERISTICS

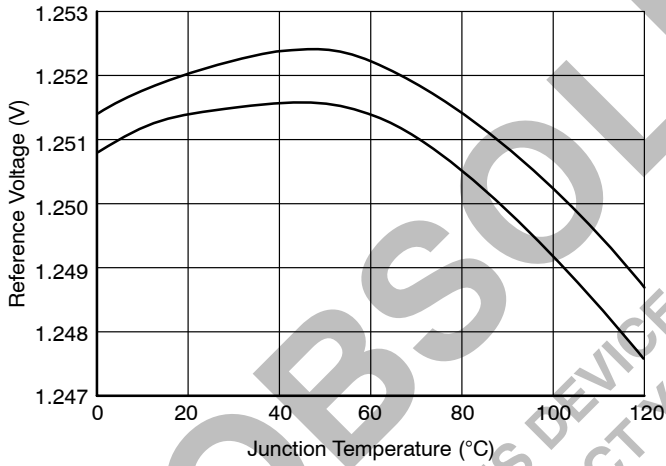

Figure 3. Reference Voltage vs Junction Temperature

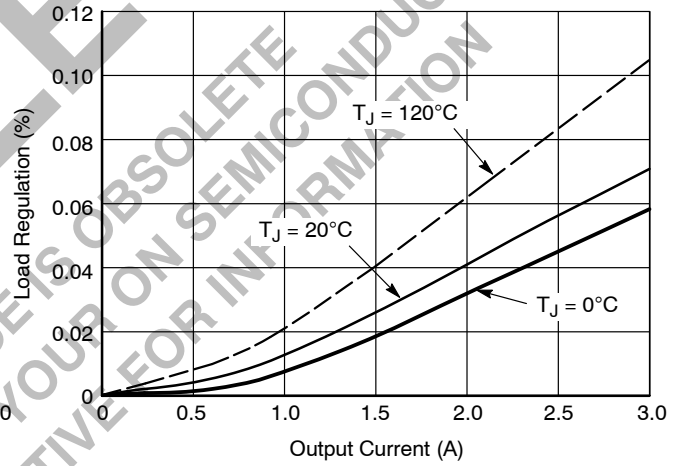

Figure 4. Load Regulation vs Output Current

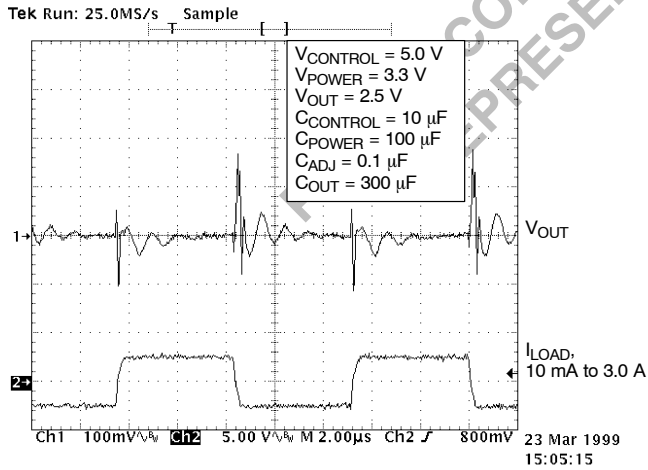

Figure 5. Transient Response

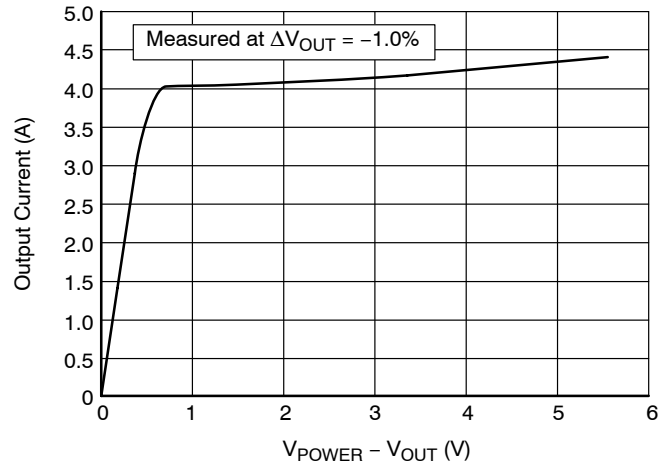

Figure 6. Output Current vs  $V_{POWER} - V_{OUT}$

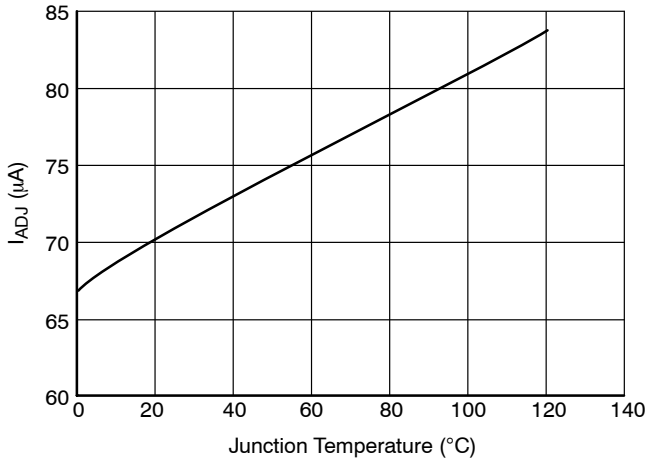

Figure 7. Adjust Pin Current vs Junction Temperature

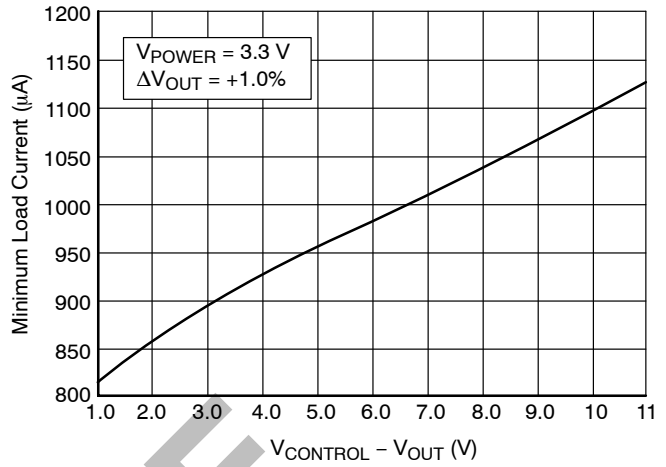

Figure 8. Minimum Load Current vs  $V_{CONTROL} - V_{OUT}$

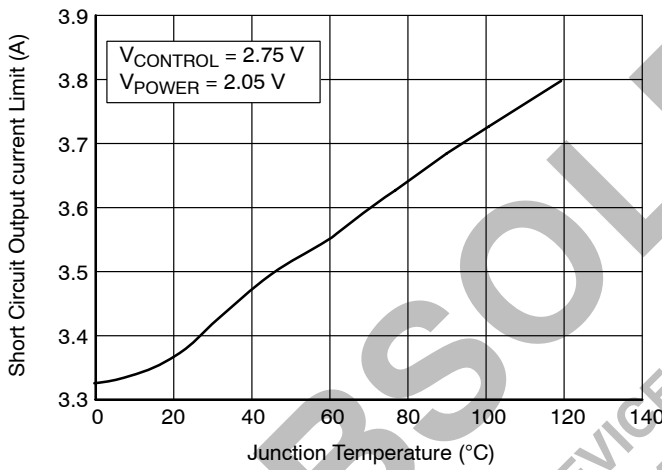

Figure 9. Short Circuit Output Current vs Junction Temperature

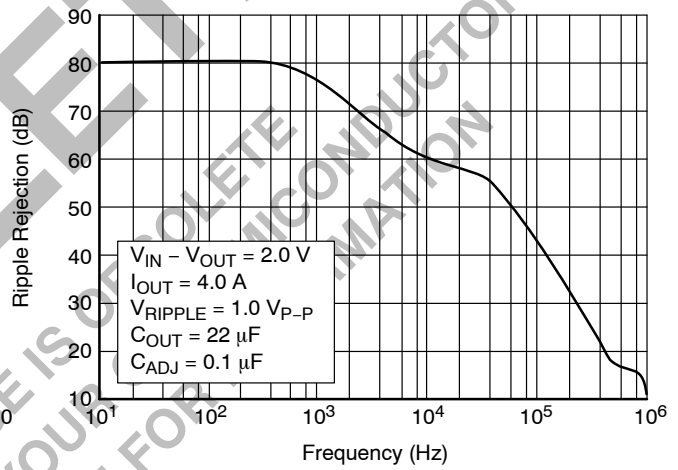

Figure 10. Ripple Rejection vs Frequency

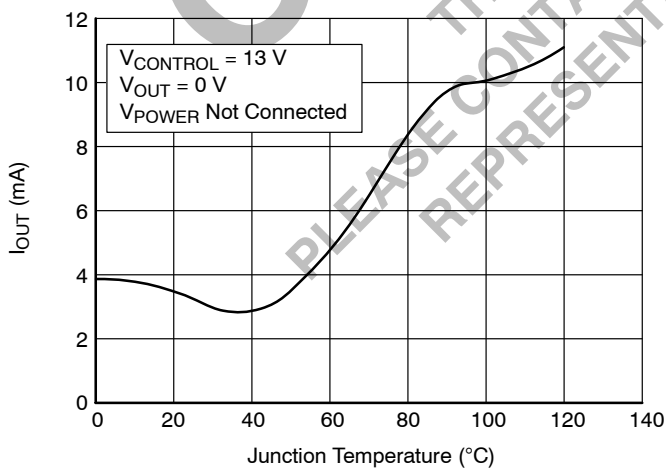

Figure 11.  $V_{CONTROL}$  Only Output Current vs Junction Temperature

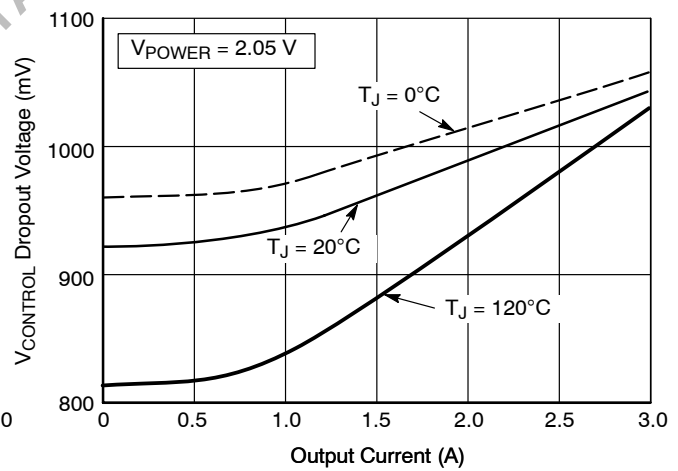

Figure 12.  $V_{CONTROL}$  Dropout Voltage vs Output Current

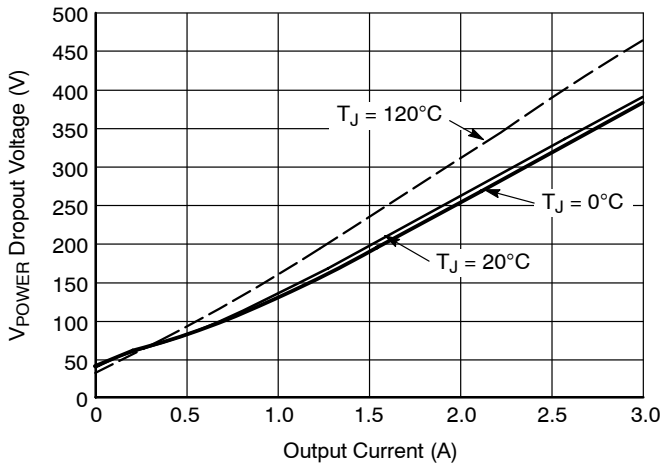

Figure 13.  $V_{POWER}$  Dropout Voltage vs Output Current

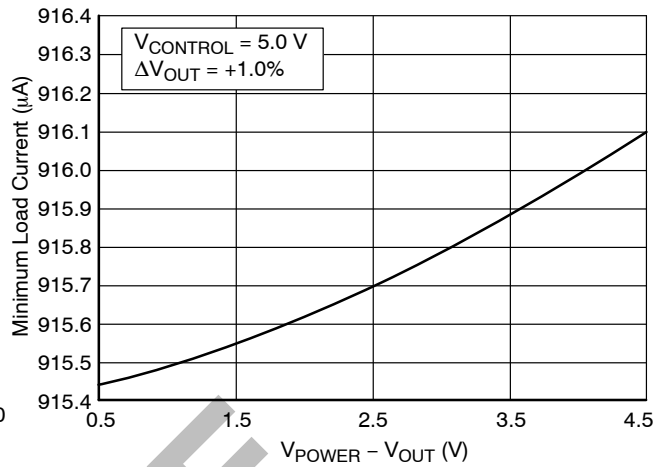

Figure 14. Minimum Load Current vs  $V_{POWER} - V_{OUT}$

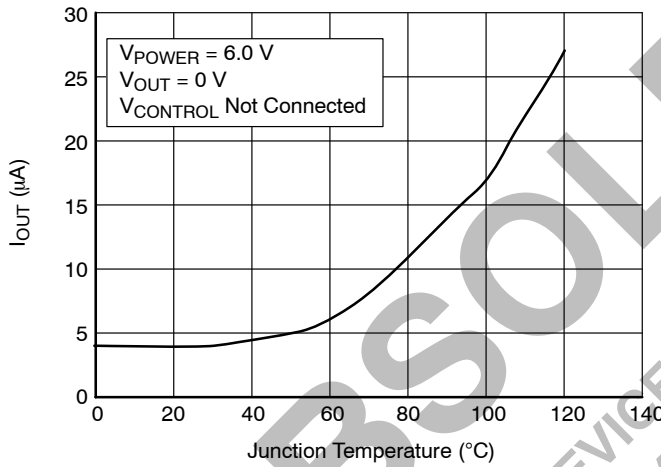

Figure 15.  $V_{POWER}$  Only Output Current vs Junction Temperature

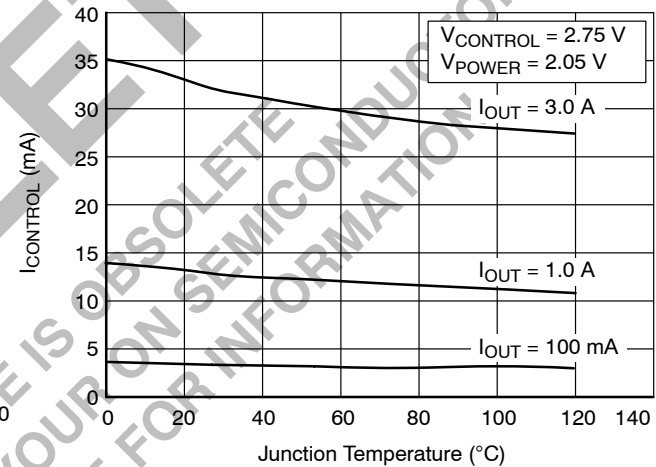

Figure 16.  $V_{CONTROL}$  Supply Current vs Junction Temperature

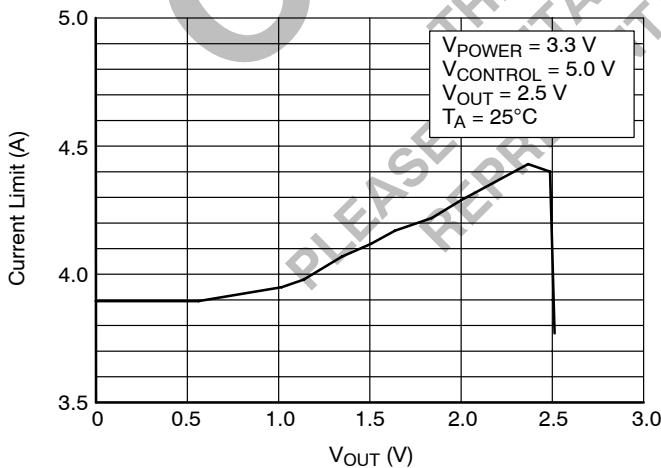

Figure 17. Current Limit vs  $V_{OUT}$

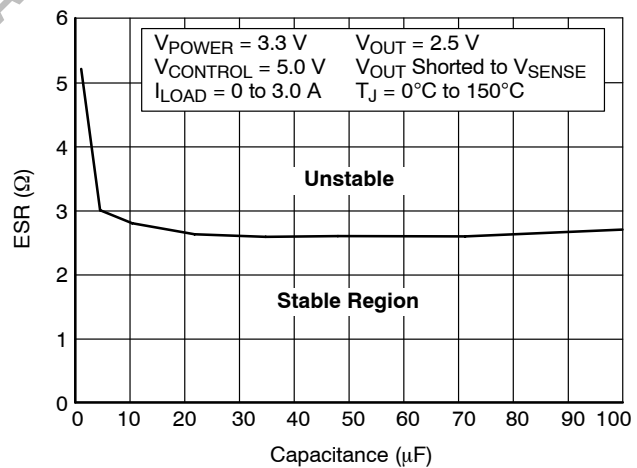

Figure 18. Stability vs ESR

## APPLICATIONS NOTES

## THEORY OF OPERATION

The CS5253-1 linear regulator provides adjustable voltages from 1.26 V to 5.0 V at currents up to 3.0 A. The regulator is protected against short circuits, and includes a thermal shutdown circuit with hysteresis. The output, which is current limited, consists of a PNP-NPN transistor pair and requires an output capacitor for stability. A detailed procedure for selecting this capacitor is included in the Stability Considerations section.

**V<sub>POWER</sub> Function**

The CS5253-1 utilizes a two supply approach to maximize efficiency. The collector of the power device is brought out to the V<sub>POWER</sub> pin to minimize internal power dissipation under high current loads. V<sub>CONTROL</sub> provides for the control circuitry and the drive for the output NPN transistor. V<sub>CONTROL</sub> should be at least 1.0 V greater than the output voltage. Special care has been taken to ensure that there are no supply sequencing problems. The output voltage will not turn on until both supplies are operating. If the control voltage comes up first, the output current will be limited to about three milliamperes until the power input voltage comes up. If the power input voltage comes up first, the output will not turn on at all until the control voltage comes up. The output can never come up unregulated.

The CS5253-1 can also be used as a single supply device with the control and power inputs tied together. In this mode, the dropout will be determined by the minimum control voltage.

**Output Voltage Sensing**

The CS5253-1 five terminal linear regulator includes a dedicated V<sub>SENSE</sub> function. This allows for true Kelvin sensing of the output voltage. This feature can virtually eliminate errors in the output voltage due to load regulation. Regulation will be optimized at the point where the sense pin is tied to the output.

## DESIGN GUIDELINES

**Adjustable Operation**

This LDO adjustable regulator has an output voltage range of 1.26 V to 5.0 V. An external resistor divider sets the output voltage as shown in Figure 19. The regulator's voltage sensing error amplifier maintains a fixed 1.260 V reference between the output pin and the adjust pin.

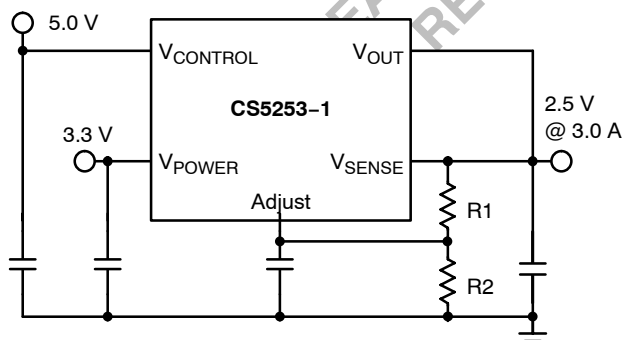

**Figure 19. Typical Application Schematic.**  
The Resistor Divider Sets V<sub>OUT</sub>, With the Internal 1.260 V Reference Dropped Across R1.

A resistor divider network R1 and R2 causes a fixed current to flow to ground. This current creates a voltage across R2 that adds to the 1.260 V across R1 and sets the overall output voltage. The adjust pin current (typically 50 μA) also flows through R2 and adds a small error that should be taken into account if precise adjustment of V<sub>OUT</sub> is necessary. The output voltage is set according to the formula:

$$V_{OUT} = 1.260 \text{ V} \times \frac{R1 + R2}{R1} + R2 \times I_{ADJ}$$

The term I<sub>ADJ</sub> × R2 represents the error added by the adjust pin current. R1 is chosen so that the minimum load current is at least 10 mA. R1 and R2 should be of the same composition for best tracking over temperature. The divider resistors should be placed physically as close to the load as possible.

While not required, a bypass capacitor connected between the adjust pin and ground will improve transient response and ripple rejection. A 0.1 μF tantalum capacitor is recommended for “first cut” design. Value and type may be varied to optimize performance vs. price.

**Other Adjustable Operation Considerations**

The CS5253-1 linear regulator has an absolute maximum specification of 6.0 V for the voltage difference between V<sub>POWER</sub> and V<sub>OUT</sub>. However, the IC may be used to regulate voltages in excess of 6.0 V. The two main considerations in such a design are the sequencing of power supplies and short circuit capability.

Power supply sequencing should be such that the V<sub>CONTROL</sub> supply is brought up coincidentally with or before the V<sub>POWER</sub> supply. This allows the IC to begin charging the output capacitor as soon as the V<sub>POWER</sub> to V<sub>OUT</sub> differential is large enough that the pass transistor conducts. As V<sub>POWER</sub> increases, the pass transistor will remain in dropout, and current is passed to the load until V<sub>OUT</sub> is in regulation. Further increase in the supply voltage brings the pass transistor out of dropout. In this manner, any output voltage less than 13 V may be regulated, provided the V<sub>POWER</sub> to V<sub>OUT</sub> differential is less than 6.0 V. In the case where V<sub>CONTROL</sub> and V<sub>POWER</sub> are shorted, there is no theoretical limit to the regulated voltage as long as the V<sub>POWER</sub> to V<sub>OUT</sub> differential of 6.0 V is not exceeded.

There is a possibility of damaging the IC when V<sub>POWER</sub> - V<sub>OUT</sub> is greater than 6.0 V if a short circuit occurs. Short circuit conditions will result in the immediate operation of the pass transistor outside of its safe operating area. Overvoltage stresses will then cause destruction of the pass transistor before overcurrent or thermal shutdown circuitry can become active. Additional circuitry may be required to clamp the V<sub>POWER</sub> to V<sub>OUT</sub> differential to less than 6.0 V if fail safe operation is required. One possible clamp circuit is illustrated in Figure 20; however, the design of clamp circuitry must be done on an application by application basis. Care must be taken to ensure the clamp actually protects the design. Components used in the clamp design must be able to withstand the short circuit condition indefinitely while protecting the IC.



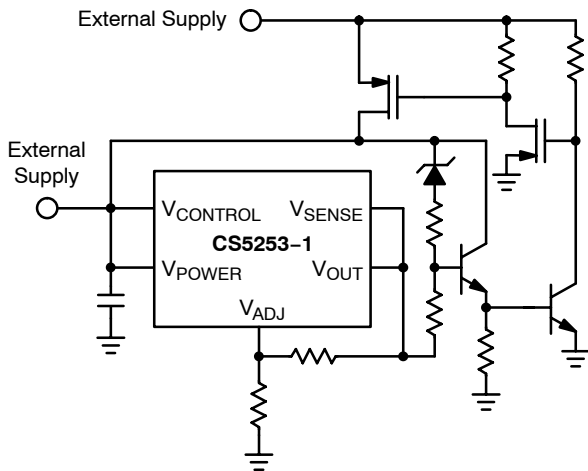

**Figure 20. This Circuit Is an Example of How the CS5253-1 Can Be Short-Circuit Protected When Operating With  $V_{OUT} > 6.0\text{ V}$**

### Stability Considerations

The output compensation capacitor helps determine three main characteristics of a linear regulator: loop stability, startup delay, and load transient response. Different capacitor types vary widely in tolerance, Equivalent Series Resistance (ESR), Equivalent Series Inductance (ESI), and variation over temperature. Tantalum and aluminum electrolytic capacitors work best, with electrolytic capacitors being less expensive in general, but varying more in capacitor value and ESR over temperature.

The CS5253-1 requires an output capacitor to guarantee loop stability. The Stability vs ESR graph in the typical performance section shows the minimum ESR needed to guarantee stability, but under ideal conditions. These include: having  $V_{OUT}$  connected to  $V_{SENSE}$  directly at the IC pins; the compensation capacitor located right at the pins with a minimum lead length; the adjust feedback resistor divider ground, (bottom of R2 in Figure 19), connected right at the capacitor ground; and with power supply decoupling capacitors located close to the IC pins. The actual performance will vary greatly with board layout for each application. In particular, the use of the remote sensing feature will require a larger capacitor with less ESR. For most applications, a minimum of 33  $\mu\text{F}$  tantalum or 150  $\mu\text{F}$  aluminum electrolytic, with an ESR less than 1.0  $\Omega$  over temperature, is recommended. Larger capacitors and lower ESR will improve stability.

The load transient response, during the time it takes the regulator to respond, is also determined by the output capacitor. For large changes in load current, the ESR of the output capacitor causes an immediate drop in output voltage given by:

$$\Delta V = \Delta I \times \text{ESR}$$

There is then an additional drop in output voltage given by:

$$\Delta V = \Delta I \times T/C$$

where T is the time for the regulation loop to begin to respond. The very fast transient response time of the CS5253-1 allows the ESR effect to dominate. For microprocessor applications, it is customary to use an output capacitor network consisting of several tantalum and ceramic capacitors in parallel. This reduces the overall ESR and reduces the instantaneous output voltage drop under transient load conditions. The output capacitor network should be as close to the load as possible for the best transient response.

### Protection Diodes

When large external capacitors are used with a linear regulator, it is sometimes necessary to add protection diodes. If the input voltage of the regulator gets shorted, the output capacitor will discharge into the output of the regulator. The discharge current depends on the value of the capacitor, the output voltage, and the rate at which  $V_{CONTROL}$  drops. In the CS5253-1 regulator, the discharge path is through a large junction and protection diodes are not usually needed. If the regulator is used with large values of output capacitance and the input voltage is instantaneously shorted to ground, damage can occur. In this case, a diode connected as shown in Figure 21 is recommended.

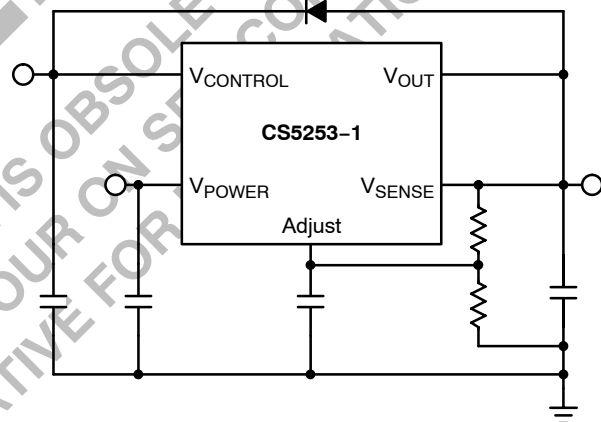

**Figure 21. Diode Protection Circuit**

A rule of thumb useful in determining if a protection diode is required is to solve for current:

$$I = \frac{C \times V}{T}$$

where:

I is the current flow out of the load capacitance when  $V_{CONTROL}$  is shorted,

C is the value of load capacitance

V is the output voltage, and

T is the time duration required for  $V_{CONTROL}$  to transition from high to being shorted.

If the calculated current is greater than or equal to the typical short circuit current value provided in the specifications, serious thought should be given to the use of a protection diode.

**Current Limit**

The internal current limit circuit limits the output current under excessive load conditions.

**Short Circuit Protection**

The device includes short circuit protection circuitry that clamps the output current at approximately 500 mA less than its current limit value. This provides for a current foldback function, which reduces power dissipation under a direct shorted load.

**Thermal Shutdown**

The thermal shutdown circuitry is guaranteed by design to activate above a die junction temperature of approximately 150°C and to shut down the regulator output. This circuitry has 25°C of typical hysteresis, thereby allowing the regulator to recover from a thermal fault automatically.

**Calculating Power Dissipation and Heat Sink Requirements**

High power regulators such as the CS5253-1 usually operate at high junction temperatures. Therefore, it is important to calculate the power dissipation and junction temperatures accurately to ensure that an adequate heat sink is used. Since the package tab is connected to V<sub>OUT</sub> on the CS5253-1, electrical isolation may be required for some applications. Also, as with all high power packages, thermal compound is necessary to ensure proper heat flow. For added safety, this high current LDO includes an internal thermal shutdown circuit.

The thermal characteristics of an IC depend on the following four factors: junction temperature, ambient temperature, die power dissipation, and the thermal resistance from the die junction-to-ambient air. The maximum junction temperature can be determined by:

$$T_{J(\max)} = T_{A(\max)} + PD(\max) \times R_{\theta JA}$$

The maximum ambient temperature and the power dissipation are determined by the design while the

maximum junction temperature and the thermal resistance depend on the manufacturer and the package type. The maximum power dissipation for a regulator is:

$$PD(\max) = (V_{IN(\max)} - V_{OUT(\min)})I_{OUT(\max)} + V_{IN(\max)} \times I_q$$

A heat sink effectively increases the surface area of the package to improve the flow of heat away from the IC and into the surrounding air. Each material in the heat flow path between the IC and the outside environment has a thermal resistance which is measured in degrees per watt. Like series electrical resistances, these thermal resistances are summed to determine the total thermal resistance between the die junction and the surrounding air, R<sub>θJA</sub>. This total thermal resistance is comprised of three components. These resistive terms are measured from junction to case (R<sub>θJC</sub>), case to heat sink (R<sub>θCS</sub>), and heat sink to ambient air (R<sub>θSA</sub>). The equation is:

$$R_{\theta JA} = R_{\theta JC} + R_{\theta CS} + R_{\theta SA}$$

The value for R<sub>θJC</sub> is 2.5°C/watt for the CS5253-1 in the D<sup>2</sup>PAK-5 package. For a high current regulator such as the CS5253-1 the majority of heat is generated in the power transistor section. The value for R<sub>θSA</sub> depends on the heat sink type, while the R<sub>θCS</sub> depends on factors such as package type, heat sink interface (is an insulator and thermal grease used?), and the contact area between the heat sink and the package. Once these calculations are complete, the maximum permissible value of R<sub>θJA</sub> can be calculated and the proper heat sink selected. For further discussion on heat sink selection, see our application note "Thermal Management," document number AND8036/D, available through the Literature Distribution Center or via our website at <http://www.onsemi.com>.

PACKAGE DIMENSIONS

D<sup>2</sup>PAK-5  
 DP SUFFIX  
 CASE 936AC-01  
 ISSUE 0

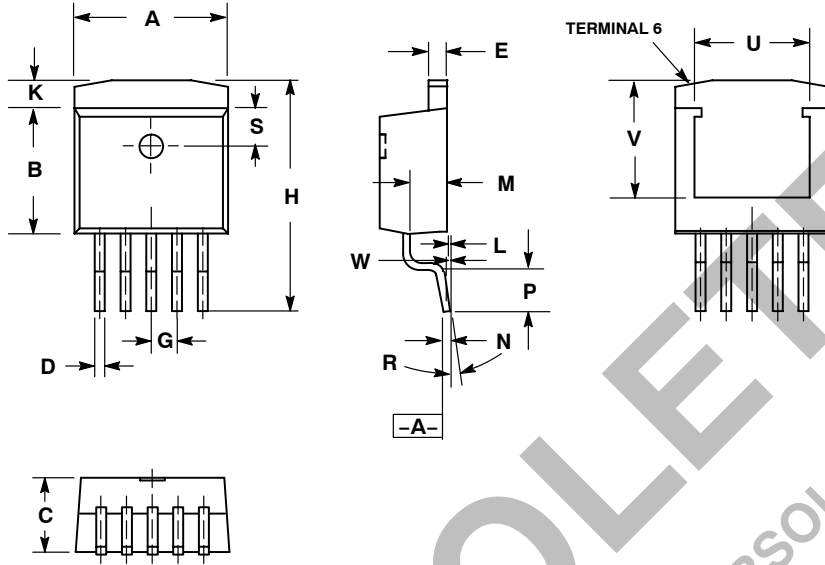

- NOTES:
1. DIMENSIONS AND TOLERANCING PER ANSI Y14.5M, 1982.
  2. CONTROLLING DIMENSION: INCH.
  3. PACKAGE OUTLINE EXCLUSIVE OF MOLD FLASH AND METAL BURR.
  4. PACKAGE OUTLINE INCLUSIVE OF PLATING THICKNESS.
  5. FOOT LENGTH MEASURED AT INTERCEPT POINT BETWEEN DATUM A AND LEAD SURFACE.

DIM	INCHES		MILLIMETERS	
	MIN	MAX	MIN	MAX
A	0.396	0.406	10.05	10.31
B	0.330	0.340	8.38	8.64
C	0.170	0.180	4.31	4.57
D	0.026	0.036	0.66	0.91
E	0.045	0.055	1.14	1.40
G	0.067 REF		1.70 REF	
H	0.580	0.620	14.73	15.75
K	0.055	0.066	1.40	1.68
L	0.000	0.010	0.00	0.25
M	0.098	0.108	2.49	2.74
N	0.017	0.023	0.43	0.58
P	0.090	0.110	2.29	2.79
R	0°	8°	0°	8°
S	0.095	0.105	2.41	2.67
U	0.30 REF		7.62 REF	
V	0.305 REF		7.75 REF	
W	0.010		0.25	

PACKAGE THERMAL DATA

Parameter		D <sup>2</sup> PAK-5	Unit
R <sub>θJC</sub>	Typical	2.5	°C/W
R <sub>θJA</sub>	Typical	10-50*	°C/W

\*Depending on thermal properties of substrate. R<sub>θJA</sub> = R<sub>θJC</sub> + R<sub>θCA</sub>.

ON Semiconductor and are registered trademarks of Semiconductor Components Industries, LLC (SCILLC). SCILLC reserves the right to make changes without further notice to any products herein. SCILLC makes no warranty, representation or guarantee regarding the suitability of its products for any particular purpose, nor does SCILLC assume any liability arising out of the application or use of any product or circuit, and specifically disclaims any and all liability, including without limitation special, consequential or incidental damages. "Typical" parameters which may be provided in SCILLC data sheets and/or specifications can and do vary in different applications and actual performance may vary over time. All operating parameters, including "Typicals" must be validated for each customer application by customer's technical experts. SCILLC does not convey any license under its patent rights nor the rights of others. SCILLC products are not designed, intended, or authorized for use as components in systems intended for surgical implant into the body, or other applications intended to support or sustain life, or for any other application in which the failure of the SCILLC product could create a situation where personal injury or death may occur. Should Buyer purchase or use SCILLC products for any such unintended or unauthorized application, Buyer shall indemnify and hold SCILLC and its officers, employees, subsidiaries, affiliates, and distributors harmless against all claims, costs, damages, and expenses, and reasonable attorney fees arising out of, directly or indirectly, any claim of personal injury or death associated with such unintended or unauthorized use, even if such claim alleges that SCILLC was negligent regarding the design or manufacture of the part. SCILLC is an Equal Opportunity/Affirmative Action Employer. This literature is subject to all applicable copyright laws and is not for resale in any manner.

PUBLICATION ORDERING INFORMATION

LITERATURE FULFILLMENT:  
 Literature Distribution Center for ON Semiconductor  
 P.O. Box 5163, Denver, Colorado 80217 USA  
 Phone: 303-675-2175 or 800-344-3860 Toll Free USA/Canada  
 Fax: 303-675-2176 or 800-344-3867 Toll Free USA/Canada  
 Email: orderlit@onsemi.com

N. American Technical Support: 800-282-9855 Toll Free  
 USA/Canada  
 Europe, Middle East and Africa Technical Support:  
 Phone: 421 33 790 2910  
 Japan Customer Focus Center  
 Phone: 81-3-5773-3850

ON Semiconductor Website: [www.onsemi.com](http://www.onsemi.com)  
 Order Literature: <http://www.onsemi.com/orderlit>  
 For additional information, please contact your local Sales Representative