

# LDO Regulator - Very Low Dropout, CMOS, Bias Rail 700 mA



**ON Semiconductor®**

[www.onsemi.com](http://www.onsemi.com)

## NCP136

The NCP136 is a 700 mA VLDO equipped with NMOS pass transistor and a separate bias supply voltage ( $V_{BIAS}$ ). The device provides very stable, accurate output voltage with low noise suitable for space constrained, noise sensitive applications. In order to optimize performance for battery operated portable applications, the NCP136 features low  $I_Q$  consumption. The WLCSP6 1.4 mm x 0.8 mm Chip Scale package is optimized for use in space constrained applications.

### Features

- Input Voltage Range:  $V_{OUT}$  to 5.5 V
- Bias Voltage Range: 2.5 V to 5.5 V
- Fixed or Adjustable Voltage Version Available
- Output Voltage Range: 0.4 V to 1.8 V (Fixed)
- $\pm 1\%$  Accuracy over Temperature,  $0.5\% V_{OUT}$  @  $25^\circ\text{C}$
- Ultra-Low Dropout: Typ. 40 mV at 700 mA
- Very Low Bias Input Current of Typ.  $80 \mu\text{A}$
- Very Low Bias Input Current in Disable Mode: Typ.  $0.5 \mu\text{A}$
- Logic Level Enable Input for ON/OFF Control
- Output Active Discharge Option Available
- Stable with a  $10 \mu\text{F}$  Ceramic Capacitor
- Available in WLCSP6 – 1.4 mm x 0.8 mm, 0.4 mm pitch Package
- These Devices are Pb-Free, Halogen Free/BFR Free and are RoHS Compliant

### Typical Applications

- Battery-powered Equipment
- Smartphones, Tablets
- Cameras, DVRs, STB and Camcorders

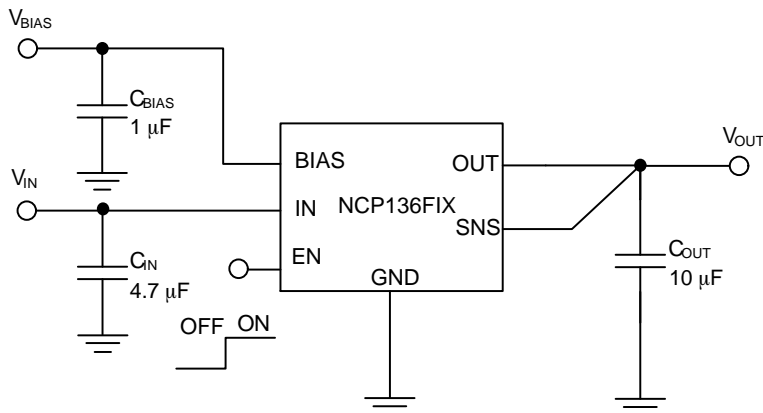

Figure 1. Typical Application Schematic – Fixed Voltage Version



WLCSP6, 1.4x0.8x0.33  
CASE 567XK



WLCSP6, 1.4x0.8x0.37  
CASE 567YU

### MARKING DIAGRAM

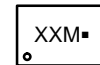

- XX = Specific Device Code
- M = Month Code
- = Pb-Free Package

### PIN CONNECTIONS

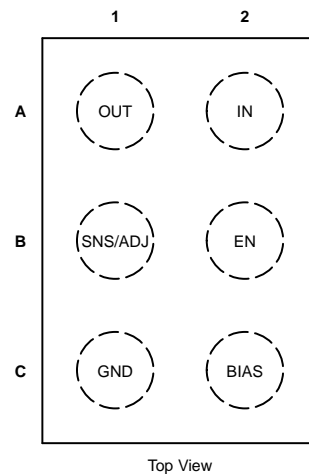

### ORDERING INFORMATION

See detailed ordering, marking and shipping information on page 12 of this data sheet.

# NCP136

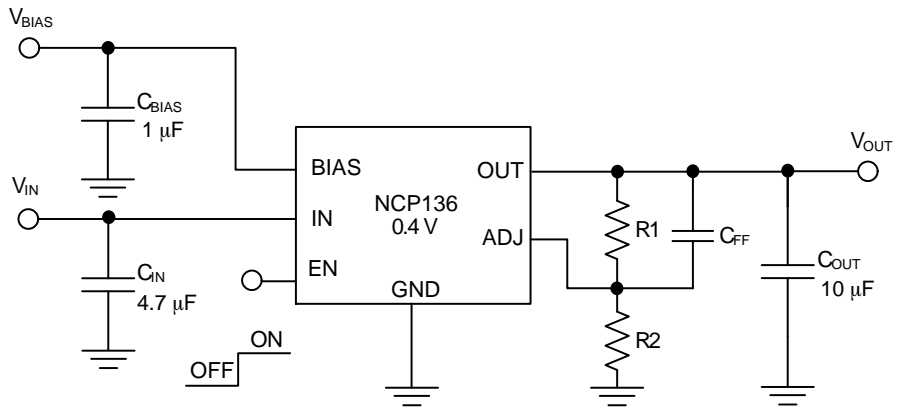
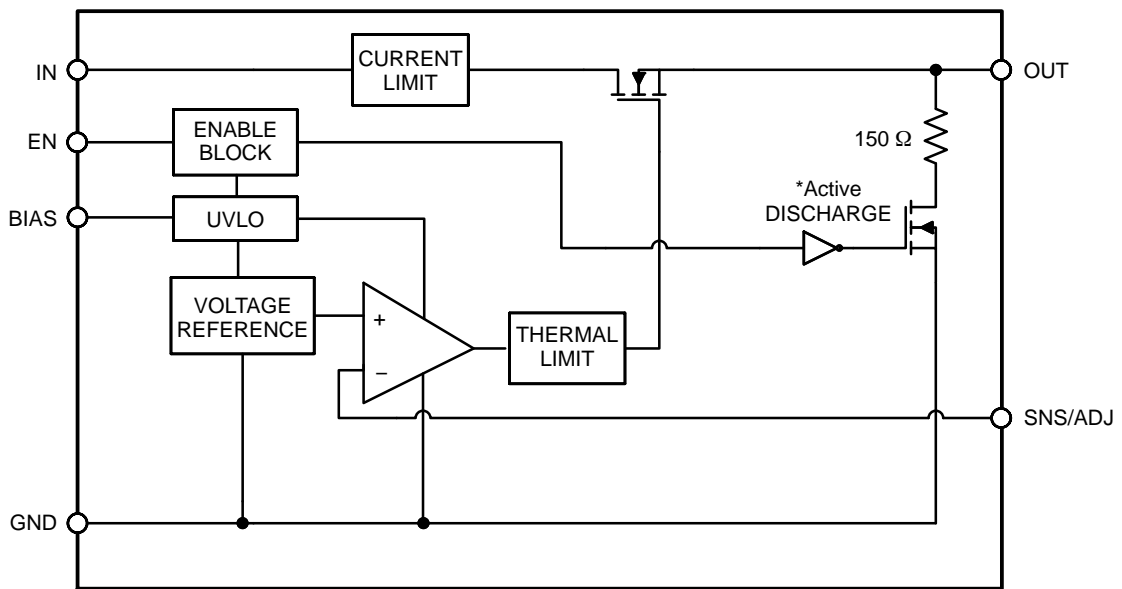

Figure 2. Typical Application Schematic – Adjustable Voltage Version



\*Active output discharge function is present only in NCP136A and NCP136C option devices.

Figure 3. Simplified Schematic Block Diagram

# NCP136

## PIN FUNCTION DESCRIPTION

Pin No. WLCSP6	Pin Name	Description
A1	OUT	Regulated Output Voltage pin
A2	IN	Input Voltage Supply pin
B1	SNS/ADJ	Feedback / adjustable input pin (connect this pin directly to the OUT pin or to the resistor divider)
B2	EN	Enable pin. Driving this pin high enables the regulator. Driving this pin low puts the regulator into shutdown mode.
C1	GND	Ground pin
C2	BIAS	Bias voltage supply for internal control circuits. This pin is monitored by internal Under-Voltage Lockout Circuit.

## ABSOLUTE MAXIMUM RATINGS

Rating	Symbol	Value	Unit
Input Voltage (Note 1)	$V_{IN}$	-0.3 to 6	V
Output Voltage	$V_{OUT}$	-0.3 to $(V_{IN}+0.3) \leq 6$	V
Chip Enable, Bias and SNS Input	$V_{EN}, V_{BIAS}, V_{SNS/ADJ}$	-0.3 to 6	V
Output Short Circuit Duration	$t_{SC}$	unlimited	s
Maximum Junction Temperature	$T_J$	150	°C
Storage Temperature	$T_{STG}$	-55 to 150	°C
ESD Capability, Human Body Model (Note 2)	$ESD_{HBM}$	2000	V
ESD Capability, Machine Model (Note 2)	$ESD_{MM}$	200	V

Stresses exceeding those listed in the Maximum Ratings table may damage the device. If any of these limits are exceeded, device functionality should not be assumed, damage may occur and reliability may be affected.

1. Refer to ELECTRICAL CHARACTERISTICS and APPLICATION INFORMATION for Safe Operating Area.
2. This device series incorporates ESD protection (except OUT pin) and is tested by the following methods:  
 ESD Human Body Model tested per EIA/JESD22-A114  
 ESD Machine Model tested per EIA/JESD22-A115  
 Latchup Current Maximum Rating tested per JEDEC standard: JESD78.

## THERMAL CHARACTERISTICS

Rating	Symbol	Value	Unit
Thermal Characteristics, WLCSP6 1.4 mm x 0.8 mm Thermal Resistance, Junction-to-Air (Note 3)	$R_{\theta JA}$	69	°C/W

3. This junction-to-ambient thermal resistance under natural convection was derived by thermal simulations based on the JEDEC JESD51 series standards methodology. Only a single device mounted at the center of a high\_K (2s2p) 80 mm x 80 mm multilayer board with 1-ounce internal planes and 2-ounce copper on top and bottom. Top copper layer has a dedicated 1.6 sqmm copper area.

# NCP136

**ELECTRICAL CHARACTERISTICS**  $-40^{\circ}\text{C} \leq T_J \leq 85^{\circ}\text{C}$ ;  $V_{\text{BIAS}} = 2.7\text{ V}$  or  $(V_{\text{OUT}} + 1.6\text{ V})$ , whichever is greater,  $V_{\text{IN}} = V_{\text{OUT(NOM)}} + 0.3\text{ V}$ ,  $I_{\text{OUT}} = 1\text{ mA}$ ,  $V_{\text{EN}} = 1\text{ V}$ ,  $C_{\text{IN}} = 4.7\text{ }\mu\text{F}$ ,  $C_{\text{OUT}} = 10\text{ }\mu\text{F}$ ,  $C_{\text{BIAS}} = 1\text{ }\mu\text{F}$ , unless otherwise noted. Typical values are at  $T_J = +25^{\circ}\text{C}$ . Min/Max values are for  $-40^{\circ}\text{C} \leq T_J \leq 85^{\circ}\text{C}$  unless otherwise noted. (Note 4)

Parameter	Test Conditions	Symbol	Min	Typ	Max	Unit
Operating Input Voltage Range		$V_{\text{IN}}$	$V_{\text{OUT}} + V_{\text{DO}}$		5.5	V
Operating Bias Voltage Range		$V_{\text{BIAS}}$	$(V_{\text{OUT}} + 1.50) \geq 2.5$		5.5	V
Undervoltage Lock-out	$V_{\text{BIAS}}$ Rising Hysteresis	UVLO		1.6 0.2		V
Output Voltage Accuracy		$V_{\text{OUT}}$		$\pm 0.5$		%
Output Voltage Accuracy	$-40^{\circ}\text{C} \leq T_J \leq 85^{\circ}\text{C}$ , $V_{\text{OUT(NOM)}} + 0.1\text{ V} \leq V_{\text{IN}} \leq V_{\text{OUT(NOM)}} + 1.0\text{ V}$ , $2.7\text{ V}$ or $(V_{\text{OUT(NOM)}} + 1.6\text{ V})$ , whichever is greater < $V_{\text{BIAS}} < 5.5\text{ V}$ , $1\text{ mA} < I_{\text{OUT}} < 700\text{ mA}$	$V_{\text{OUT}}$	-1.0		+1.0	%
$V_{\text{IN}}$ Line Regulation	$V_{\text{OUT(NOM)}} + 0.1\text{ V} \leq V_{\text{IN}} \leq 5.0\text{ V}$	LineReg		0.01		%/V
$V_{\text{BIAS}}$ Line Regulation	$2.7\text{ V}$ or $(V_{\text{OUT(NOM)}} + 1.6\text{ V})$ , whichever is greater < $V_{\text{BIAS}} < 5.5\text{ V}$	LineReg		0.01		%/V
Load Regulation	$I_{\text{OUT}} = 1\text{ mA}$ to $700\text{ mA}$	LoadReg		1.5		mV
$V_{\text{IN}}$ Dropout Voltage	$I_{\text{OUT}} = 700\text{ mA}$ (Note 5)	$V_{\text{DO}}$		40	60	mV
$V_{\text{BIAS}}$ Dropout Voltage	$I_{\text{OUT}} = 700\text{ mA}$ , $V_{\text{IN}} = V_{\text{BIAS}}$ (Notes 5, 6)	$V_{\text{DO}}$		1.1	1.5	V
Output Current Limit	$V_{\text{OUT}} = 90\% V_{\text{OUT(NOM)}}$	$I_{\text{CL}}$	800	1450	2000	mA
SNS/ADJ Pin Operating Current		$I_{\text{SNS}}$		0.1	0.5	$\mu\text{A}$
Bias Pin Quiescent Current	$V_{\text{BIAS}} = 2.7\text{ V}$ , $I_{\text{OUT}} = 0\text{ mA}$	$I_{\text{BIASQ}}$		70	110	$\mu\text{A}$
Bias Pin Disable Current	$V_{\text{EN}} \leq 0.4\text{ V}$	$I_{\text{BIAS(DIS)}}$		0.5	1	$\mu\text{A}$
Input Pin Disable Current	$V_{\text{EN}} \leq 0.4\text{ V}$	$I_{\text{VIN(DIS)}}$		0.5	1	$\mu\text{A}$
EN Pin Threshold Voltage	EN Input Voltage "H"	$V_{\text{EN(H)}}$	0.9			V
	EN Input Voltage "L"	$V_{\text{EN(L)}}$			0.4	
EN Pull Down Current	$V_{\text{EN}} = 5.5\text{ V}$	$I_{\text{EN}}$		0.3	1	$\mu\text{A}$
Power Supply Rejection Ratio	$V_{\text{IN}}$ to $V_{\text{OUT}}$ , $f = 1\text{ kHz}$ , $I_{\text{OUT}} = 10\text{ mA}$ , $V_{\text{IN}} \geq V_{\text{OUT}} + 0.5\text{ V}$ , $V_{\text{OUT(NOM)}} = 1.2\text{ V}$ , $V_{\text{BIAS}} = 3.0\text{ V}$	PSRR( $V_{\text{IN}}$ )		75		dB
	$V_{\text{BIAS}}$ to $V_{\text{OUT}}$ , $f = 1\text{ kHz}$ , $I_{\text{OUT}} = 10\text{ mA}$ , $V_{\text{IN}} \geq V_{\text{OUT}} + 0.5\text{ V}$ , $V_{\text{OUT(NOM)}} = 1.2\text{ V}$ , $V_{\text{BIAS}} = 3.0\text{ V}$	PSRR( $V_{\text{BIAS}}$ )		80		dB
Output Noise Voltage	$V_{\text{IN}} = V_{\text{OUT}} + 0.5\text{ V}$ , $f = 10\text{ Hz}$ to $100\text{ kHz}$ , $V_{\text{OUT(NOM)}} = 1.2\text{ V}$	$V_{\text{N}}$		40		$\mu\text{V}_{\text{RMS}}$
Thermal Shutdown Threshold	Temperature increasing			160		$^{\circ}\text{C}$
	Temperature decreasing			140		
Output Discharge Pull-Down	$V_{\text{EN}} \leq 0.4\text{ V}$ , $V_{\text{OUT}} = 0.5\text{ V}$ , NCP136A and NCP136C option	$R_{\text{DISCH}}$		150		$\Omega$

Product parametric performance is indicated in the Electrical Characteristics for the listed test conditions, unless otherwise noted. Product performance may not be indicated by the Electrical Characteristics if operated under different conditions.

4. Performance guaranteed over the indicated operating temperature range by design and/or characterization. Production tested at  $T_A = 25^{\circ}\text{C}$ . Low duty cycle pulse techniques are used during the testing to maintain the junction temperature as close to ambient as possible.
5. Dropout voltage is characterized when  $V_{\text{OUT}}$  falls 3% below  $V_{\text{OUT(NOM)}}$ .
6. For fixed output voltages below 1.5 V,  $V_{\text{BIAS}}$  dropout does not apply due to a minimum Bias operating voltage of 2.5 V.

# NCP136

**ELECTRICAL CHARACTERISTICS**  $-40^{\circ}\text{C} \leq T_J \leq 85^{\circ}\text{C}$ ;  $I_{\text{OUT}} = 1 \text{ mA}$ ,  $V_{\text{EN}} = 1 \text{ V}$ ,  $C_{\text{IN}} = 4.7 \mu\text{F}$ ,  $C_{\text{OUT}} = 10 \mu\text{F}$ ,  $C_{\text{BIAS}} = 1 \mu\text{F}$ . Typical values are at  $T_J = +25^{\circ}\text{C}$ . Min/Max values are for  $-40^{\circ}\text{C} \leq T_J \leq 85^{\circ}\text{C}$  unless otherwise noted. (Note 7)

Parameter	Test conditions	Symbol	Min	Typ	Max	Unit
-----------	-----------------	--------	-----	-----	-----	------

**NCP136xFCRC040T2G**  $V_{\text{BIAS}} = 3 \text{ V}$ ,  $V_{\text{IN}} = 0.6 \text{ V}$

Delay time	From assertion of $V_{\text{EN}}$ to output voltage increase	'A' option	$t_{\text{DELAY}}$		73	$\mu\text{s}$
Rise time	$V_{\text{OUT}}$ rise from 10% to 90% $V_{\text{OUT(NOM)}}$	'A' option	$t_{\text{RISE}}$		15	
Turn-On Time	From assertion of $V_{\text{EN}}$ to $V_{\text{OUT}} = 98\% V_{\text{OUT(NOM)}}$	'A' option	$t_{\text{ON}}$		98	

**NCP136xFCT080T2G & NCP136xFCRC080T2G**  $V_{\text{BIAS}} = 3 \text{ V}$ ,  $V_{\text{IN}} = 1.0 \text{ V}$

Delay time	From assertion of $V_{\text{EN}}$ to output voltage increase	'A' and 'B' option	$t_{\text{DELAY}}$		55	$\mu\text{s}$
Rise time	$V_{\text{OUT}}$ rise from 10% to 90% $V_{\text{OUT(NOM)}}$	'A' and 'B' option	$t_{\text{RISE}}$		17	
Turn-On Time	From assertion of $V_{\text{EN}}$ to $V_{\text{OUT}} = 98\% V_{\text{OUT(NOM)}}$	'A' and 'B' option	$t_{\text{ON}}$		80	

**NCP136xFCT088T2G**  $V_{\text{BIAS}} = 3 \text{ V}$ ,  $V_{\text{IN}} = 1.1 \text{ V}$

Delay time	From assertion of $V_{\text{EN}}$ to output voltage increase	'A' option	$t_{\text{DELAY}}$		71	$\mu\text{s}$
Rise time	$V_{\text{OUT}}$ rise from 10% to 90% $V_{\text{OUT(NOM)}}$	'A' option	$t_{\text{RISE}}$		16	
Turn-On Time	From assertion of $V_{\text{EN}}$ to $V_{\text{OUT}} = 98\% V_{\text{OUT(NOM)}}$	'A' option	$t_{\text{ON}}$		97	

**NCP136xFCT105T2G**  $V_{\text{BIAS}} = 3 \text{ V}$ ,  $V_{\text{IN}} = 1.25 \text{ V}$

Delay time	From assertion of $V_{\text{EN}}$ to output voltage increase	'A' option	$t_{\text{DELAY}}$		71	$\mu\text{s}$
Rise time	$V_{\text{OUT}}$ rise from 10% to 90% $V_{\text{OUT(NOM)}}$	'A' option	$t_{\text{RISE}}$		18	
Turn-On Time	From assertion of $V_{\text{EN}}$ to $V_{\text{OUT}} = 98\% V_{\text{OUT(NOM)}}$	'A' option	$t_{\text{ON}}$		102	

**NCP136xFCT110T2G**  $V_{\text{BIAS}} = 3 \text{ V}$ ,  $V_{\text{IN}} = 1.3 \text{ V}$

Delay time	From assertion of $V_{\text{EN}}$ to output voltage increase	'A' option	$t_{\text{DELAY}}$		71	$\mu\text{s}$
Rise time	$V_{\text{OUT}}$ rise from 10% to 90% $V_{\text{OUT(NOM)}}$	'A' option	$t_{\text{RISE}}$		19	
Turn-On Time	From assertion of $V_{\text{EN}}$ to $V_{\text{OUT}} = 98\% V_{\text{OUT(NOM)}}$	'A' option	$t_{\text{ON}}$		105	

**NCP136xFCT120T2G**  $V_{\text{BIAS}} = 3 \text{ V}$ ,  $V_{\text{IN}} = 1.4 \text{ V}$

Delay time	From assertion of $V_{\text{EN}}$ to output voltage increase	'A' option	$t_{\text{ON}}$		70	$\mu\text{s}$
		'C' option			80	
Rise time	$V_{\text{OUT}}$ rise from 10% to 90% $V_{\text{OUT(NOM)}}$	'A' option	$t_{\text{RISE}}$		21	
		'C' option			80	
Turn-On Time	From assertion of $V_{\text{EN}}$ to $V_{\text{OUT}} = 98\% V_{\text{OUT(NOM)}}$	'A' option	$t_{\text{ON}}$		108	
		'C' option			210	

Product parametric performance is indicated in the Electrical Characteristics for the listed test conditions, unless otherwise noted. Product performance may not be indicated by the Electrical Characteristics if operated under different conditions.

7. Performance guaranteed over the indicated operating temperature range by design and/or characterization. Production tested at  $T_A = 25^{\circ}\text{C}$ . Low duty cycle pulse techniques are used during the testing to maintain the junction temperature as close to ambient as possible.

TYPICAL CHARACTERISTICS

At  $T_J = +25^\circ\text{C}$ ,  $V_{IN} = V_{OUT(NOM)} + 0.3\text{ V}$ ,  $V_{BIAS} = 2.8\text{ V}$ ,  $V_{EN} = V_{BIAS}$ ,  $V_{OUT(NOM)} = 1.2\text{ V}$ ,  $I_{OUT} = 700\text{ mA}$ ,  $C_{IN} = 4.7\text{ }\mu\text{F}$ ,  $C_{BIAS} = 1\text{ }\mu\text{F}$ , and  $C_{OUT} = 10\text{ }\mu\text{F}$  (effective capacitance), unless otherwise noted.

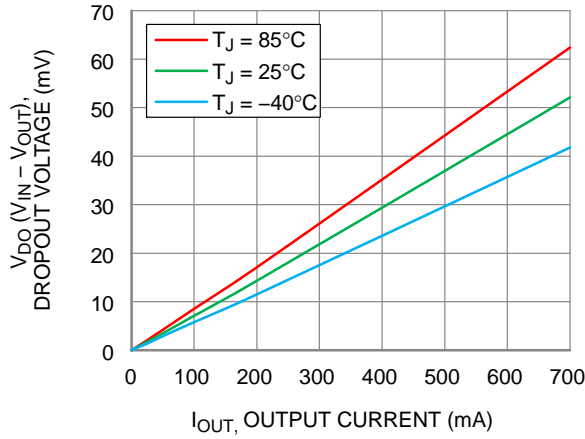

Figure 4.  $V_{IN}$  Dropout Voltage vs.  $I_{OUT}$  and  $T_J$

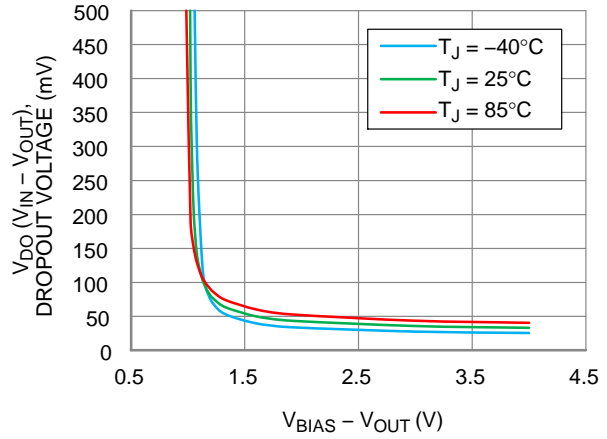

Figure 5.  $V_{IN}$  Dropout Voltage vs.  $V_{BIAS} - V_{OUT}$  and  $T_J$

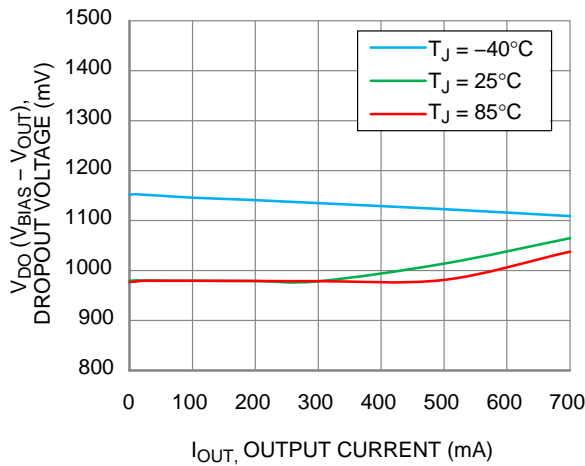

Figure 6.  $V_{BIAS}$  Dropout Voltage vs.  $I_{OUT}$  and  $T_J$

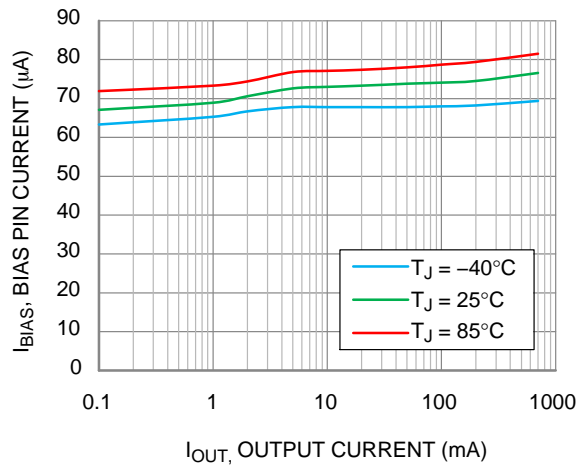

Figure 7. BIAS Pin Current vs.  $I_{OUT}$  and  $T_J$

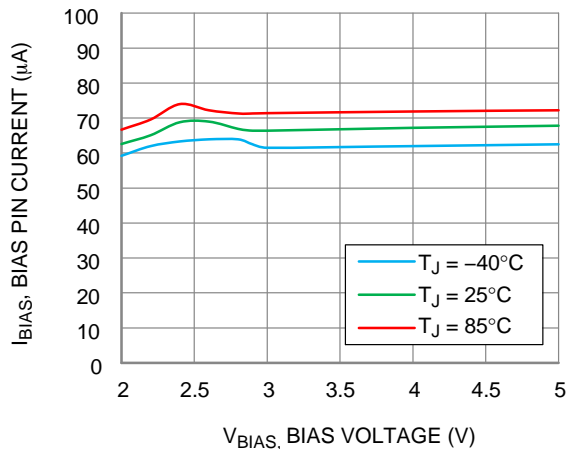

Figure 8. BIAS Pin Current vs.  $V_{BIAS}$  and  $T_J$

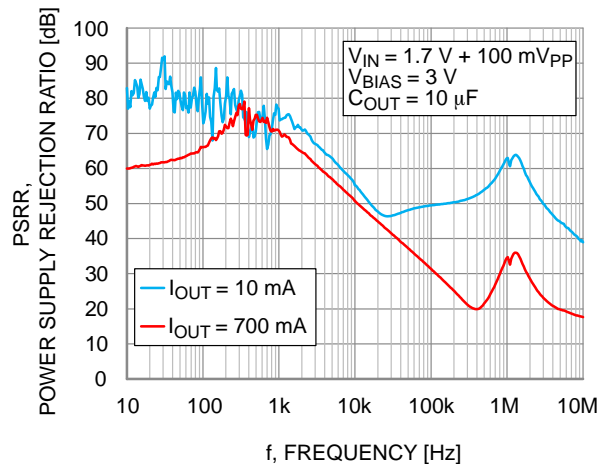
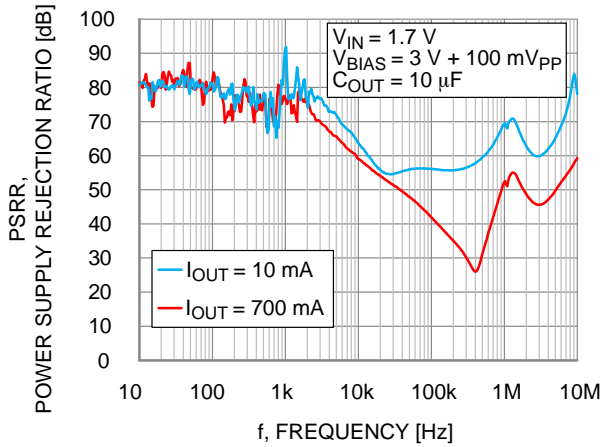

Figure 9.  $V_{IN}$  PSRR vs. Frequency

**TYPICAL CHARACTERISTICS** (continued)

At  $T_J = +25^\circ\text{C}$ ,  $V_{IN} = V_{OUT(NOM)} + 0.3\text{ V}$ ,  $V_{BIAS} = 2.8\text{ V}$ ,  $V_{EN} = V_{BIAS}$ ,  $V_{OUT(NOM)} = 1.2\text{ V}$ ,  $I_{OUT} = 700\text{ mA}$ ,  $C_{IN} = 4.7\text{ }\mu\text{F}$ ,  $C_{BIAS} = 1\text{ }\mu\text{F}$ , and  $C_{OUT} = 10\text{ }\mu\text{F}$  (effective capacitance), unless otherwise noted.



**Figure 10.  $V_{BIAS}$  PSRR vs. Frequency**

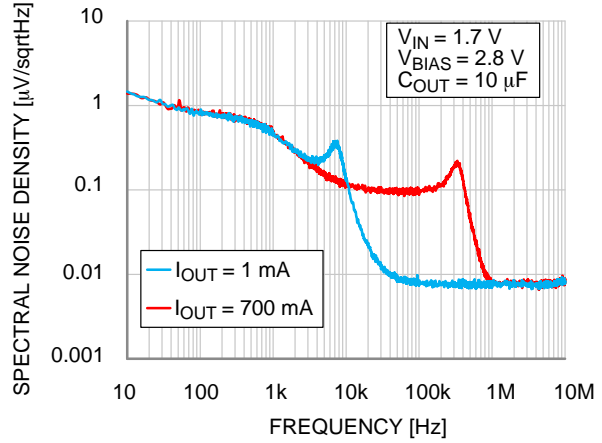

**Figure 11. Output Voltage Spectral Noise Density vs. Frequency**

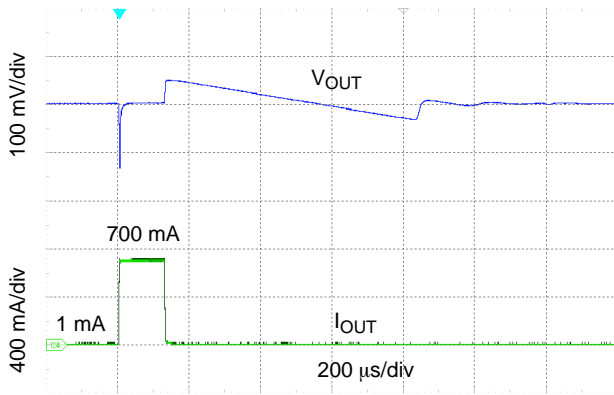

**Figure 12. Load Transient Response,  $I_{OUT} = 1\text{ mA}$  to  $700\text{ mA}$  in  $1\text{ }\mu\text{s}$ ,  $C_{OUT} = 10\text{ }\mu\text{F}$**

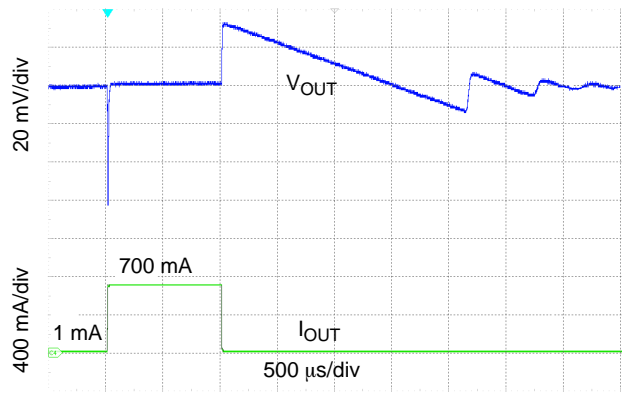

**Figure 13. Load Transient Response,  $I_{OUT} = 1\text{ mA}$  to  $700\text{ mA}$  in  $1\text{ }\mu\text{s}$ ,  $C_{OUT} = 47\text{ }\mu\text{F}$**

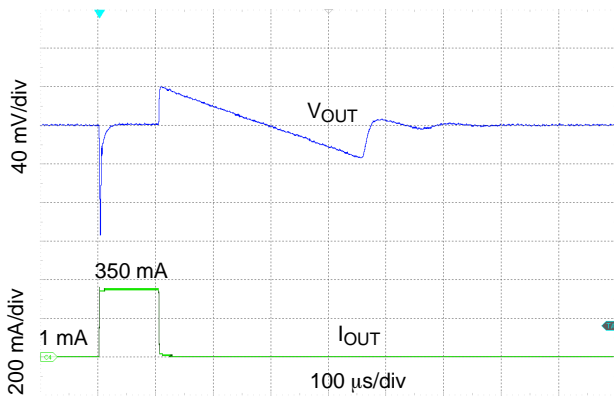

**Figure 14. Load Transient Response,  $I_{OUT} = 1\text{ mA}$  to  $350\text{ mA}$  in  $1\text{ }\mu\text{s}$ ,  $C_{OUT} = 4.7\text{ }\mu\text{F}$**

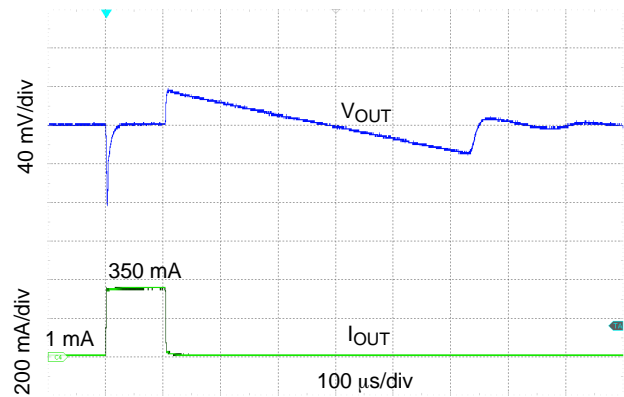

**Figure 15. Load Transient Response,  $I_{OUT} = 1\text{ mA}$  to  $350\text{ mA}$  in  $1\text{ }\mu\text{s}$ ,  $C_{OUT} = 10\text{ }\mu\text{F}$**

**TYPICAL CHARACTERISTICS** (continued)

At  $T_J = +25^\circ\text{C}$ ,  $V_{IN} = V_{OUT(NOM)} + 0.3\text{ V}$ ,  $V_{BIAS} = 2.8\text{ V}$ ,  $V_{EN} = V_{BIAS}$ ,  $V_{OUT(NOM)} = 1.2\text{ V}$ ,  $I_{OUT} = 700\text{ mA}$ ,  $C_{IN} = 4.7\text{ }\mu\text{F}$ ,  $C_{BIAS} = 1\text{ }\mu\text{F}$ , and  $C_{OUT} = 10\text{ }\mu\text{F}$  (effective capacitance), unless otherwise noted.

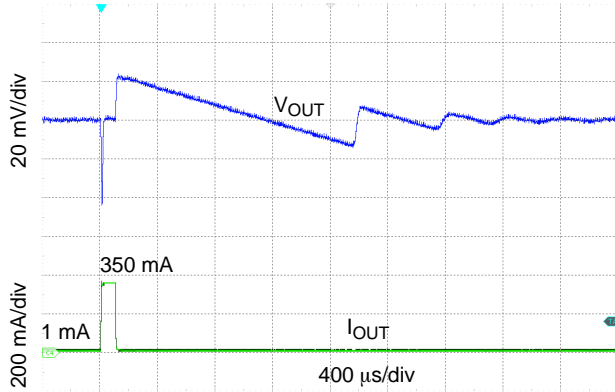

**Figure 16. Load Transient Response,**  
 $I_{OUT} = 1\text{ mA}$  to  $350\text{ mA}$  in  $1\text{ }\mu\text{s}$ ,  $C_{OUT} = 47\text{ }\mu\text{F}$

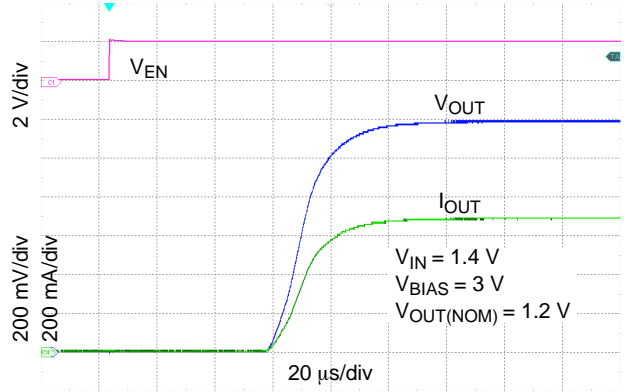

**Figure 17. Enable Transient Response,  $C_{OUT} = 10\text{ }\mu\text{F}$ ,**  
 $I_{OUT} = 700\text{ mA}$  – A Option (Normal)

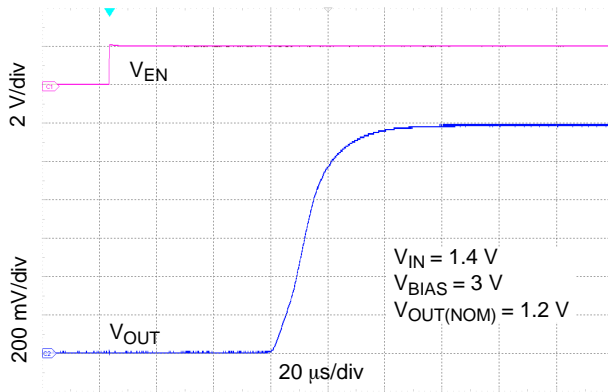

**Figure 18. Enable Transient Response,  $C_{OUT} = 10\text{ }\mu\text{F}$ ,**  
 $I_{OUT} = 0\text{ mA}$  – A Option (Normal)

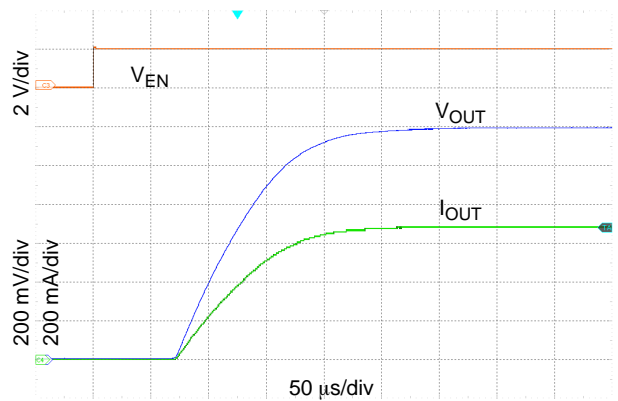

**Figure 19. Enable Transient Response,**  
 $C_{OUT} = 10\text{ }\mu\text{F}$ ,  $I_{OUT} = 700\text{ mA}$  – C Option (Slow)

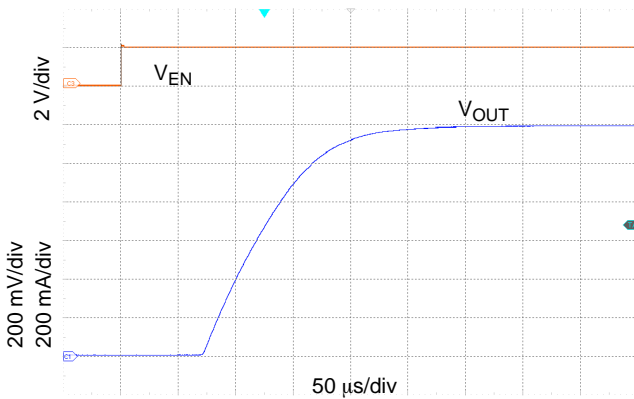

**Figure 20. Enable Transient Response,**  
 $C_{OUT} = 10\text{ }\mu\text{F}$ ,  $I_{OUT} = 0\text{ mA}$  – C Option (Slow)

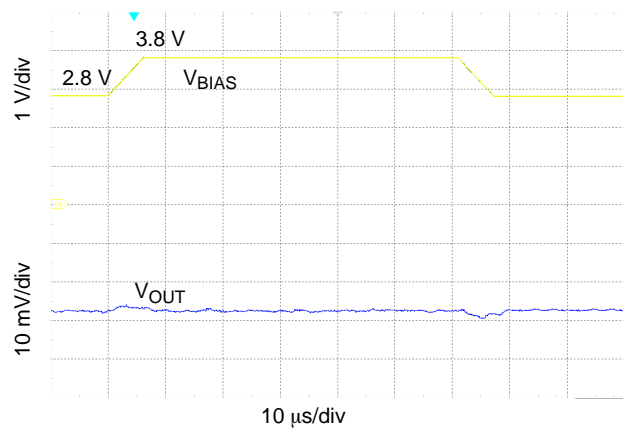

**Figure 21. BIAS Line Transient Response,**  
 $V_{BIAS} = 2.8\text{ V}$  to  $3.8\text{ V}$  in  $5\text{ }\mu\text{s}$



# NCP136

## TYPICAL CHARACTERISTICS (continued)

At  $T_J = +25^\circ\text{C}$ ,  $V_{IN} = V_{OUT(\text{NOM})} + 0.3\text{ V}$ ,  $V_{BIAS} = 2.8\text{ V}$ ,  $V_{EN} = V_{BIAS}$ ,  $V_{OUT(\text{NOM})} = 1.2\text{ V}$ ,  $I_{OUT} = 700\text{ mA}$ ,  $C_{IN} = 4.7\text{ }\mu\text{F}$ ,  $C_{BIAS} = 1\text{ }\mu\text{F}$ , and  $C_{OUT} = 10\text{ }\mu\text{F}$  (effective capacitance), unless otherwise noted.

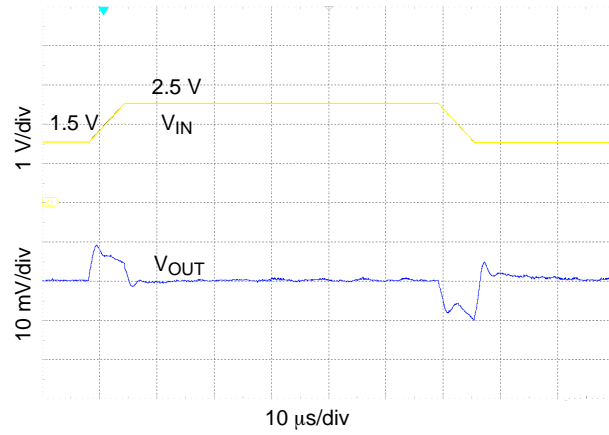

**Figure 22. IN Line Transient Response,  
 $V_{IN} = 1.5\text{ V}$  to  $2.5\text{ V}$  in  $5\text{ }\mu\text{s}$**

APPLICATIONS INFORMATION

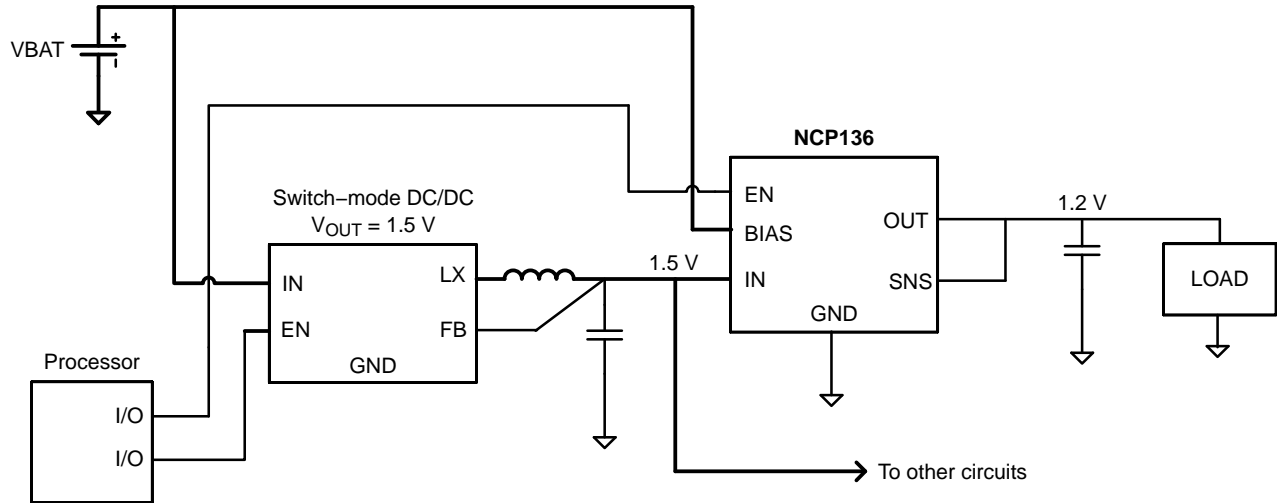

Figure 23. Typical Application: Low-Voltage DC/DC Post-Regulator with ON/OFF Functionality

The NCP136 dual-rail very low dropout voltage regulator is using NMOS pass transistor for output voltage regulation from  $V_{IN}$  voltage. All the low current internal control circuitry is powered from the  $V_{BIAS}$  voltage.

The use of an NMOS pass transistor offers several advantages in applications. Unlike PMOS topology devices, the output capacitor has reduced impact on loop stability.  $V_{in}$  to  $V_{out}$  operating voltage difference can be very low compared with standard PMOS regulators in very low  $V_{in}$  applications.

The NCP136 offers smooth monotonic start-up. The controlled voltage rising limits the inrush current.

The Enable (EN) input is equipped with internal hysteresis. NCP136 Voltage linear regulator Fixed version is available.

**Dropout Voltage**

Because of two power supply inputs  $V_{IN}$  and  $V_{BIAS}$  and one  $V_{OUT}$  regulator output, there are two Dropout voltages specified.

The first, the  $V_{IN}$  Dropout voltage is the voltage difference ( $V_{IN} - V_{OUT}$ ) when  $V_{OUT}$  starts to decrease by percent specified in the Electrical Characteristics table.  $V_{BIAS}$  is high enough; specific value is published in the Electrical Characteristics table.

The second,  $V_{BIAS}$  dropout voltage is the voltage difference ( $V_{BIAS} - V_{OUT}$ ) when  $V_{IN}$  and  $V_{BIAS}$  pins are joined together and  $V_{OUT}$  starts to decrease.

**Input and Output Capacitors**

The NCP136 device is designed to be stable for ceramic output capacitors with Effective capacitance in the range from 4.7  $\mu\text{F}$  to 47  $\mu\text{F}$ . The device is also stable with multiple capacitors in parallel, having the total effective capacitance in the specified range.

In applications where no low input supplies impedance available (PCB inductance in  $V_{IN}$  and/or  $V_{BIAS}$  inputs as example), the recommended  $C_{IN} = 1 \mu\text{F}$  and  $C_{BIAS} = 0.1 \mu\text{F}$  or greater. Ceramic capacitors are recommended. For the best performance all the capacitors should be connected to the NCP136 respective pins directly in the device PCB copper layer, not through vias having not negligible impedance.

When using small ceramic capacitor, their capacitance is not constant but varies with applied DC biasing voltage, temperature and tolerance. The effective capacitance can be much lower than their nominal capacitance value, most importantly in negative temperatures and higher LDO output voltages. That is why the recommended Output capacitor capacitance value is specified as Effective value in the specific application conditions.

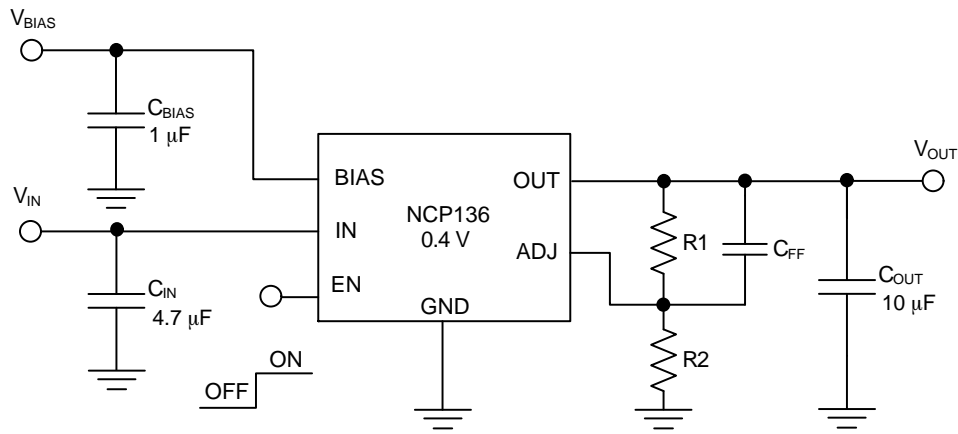

Figure 24. Typical Application Schematic – Adjustable

**Output Voltage Adjustment**

The required output voltage can be adjusted from 0.4 V to 1.8 V using two external resistors. Typical application schematics is shown in Figure 24. Output voltage is calculated according to equation 1. Generally, any voltage option can be used as adjustable, in the equation below  $V_{OUT-ADJ}$  is requested voltage and  $V_{OUT-NOM}$  is nominal  $V_{OUT}$  as reference voltage. When resistor's value is in kΩ range last term ( $I_{ADJ} \cdot R_1$ ) can be omitted because its effect on output voltage accuracy is negligible. In other cases it should be considered especially when tight output voltage accuracy is requested.

$$V_{OUT-ADJ} = V_{OUT-NOM} \cdot \left( 1 + \frac{R_1}{R_2} \right) + I_{ADJ} \cdot R_1 \quad (\text{eq. 1})$$

Voltage Calculation Example –  $V_{OUT} = 0.8 \text{ V}$ :

- a.  $R_1 = R_2 = 5.1 \text{ k}\Omega$ , no ( $I_{FB} \times R_1$ )  
 $V_{OUT-ADJ} = 0.4 \cdot (1 + 5.1 \text{ k}\Omega / 5.1 \text{ k}\Omega) = 0.8 \text{ V}$   
 Error – 0%
- b.  $R_1 = R_2 = 5.1 \text{ k}\Omega$   
 $V_{OUT-ADJ} = 0.4 \cdot (1 + 5.1 \text{ k}\Omega / 5.1 \text{ k}\Omega) + 100 \text{ nA} \cdot 5.1 \text{ k}\Omega = 0.80051 \text{ V}$   
 Error – 0.06%

- c.  $R_1 = R_2 = 51 \text{ k}\Omega$   
 $V_{OUT-ADJ} = 0.4 \cdot (1 + 51 \text{ k}\Omega / 51 \text{ k}\Omega) + 100 \text{ nA} \cdot 51 \text{ k}\Omega = 0.8051 \text{ V}$   
 Error – 0.63%

It is recommended to keep the total resistance of resistors ( $R_1 + R_2$ ) no greater than a few hundred kΩ. If total resistance is too big the dynamic performance could get worse due to PCB parasitic capacitance. Big resistor values in combination with parasitic capacitance create low-pass filter and virtually slow-down LDO control loop.

Output Voltage Example:

$V_{OUT}(V)$	$R_1 (k\Omega)$ (Note 1)	$R_2 (k\Omega)$ (Note 1)	$C_{FF} (nF)$
0.80	5.1	5.1	5.6
1.05	3.9	2.4	5.6
1.10	8.2	4.7	5.6

1. To increase power efficiency, current flows through resistor divider can be reduced by multiply all resistor values by 10.

**Feed Forward Capacitor  $C_{FF}$**

Feedforward capacitor is recommended to improve PSRR, load transient and noise performance. Recommended value for NCP136 device is about 5.6 nF. The capacitor can also improve LDO stability.

# NCP136

## Enable Operation

The enable pin will turn the regulator on or off. The threshold limits are covered in the electrical characteristics table in this data sheet. To get the full functionality of Soft Start, it is recommended to turn on the  $V_{IN}$  and  $V_{BIAS}$  supply voltages first and activate the Enable pin no sooner than  $V_{IN}$  and  $V_{BIAS}$  are on their nominal levels. If the enable function is not to be used then the pin should be connected to  $V_{IN}$  or  $V_{BIAS}$ .

If the EN pin voltage is  $< 0.4$  V the device is guaranteed to be disabled. The pass transistor is turned off so that there is virtually no current flow between the IN and OUT. The active discharge transistor is active (devices with Output Active Discharge feature only) so that the output voltage  $V_{OUT}$  is pulled down to GND through a 150  $\Omega$  resistor. In the disable state the device consumes as low as typ. 0.5  $\mu$ A from the  $V_{IN}$  and 0.5  $\mu$ A from  $V_{BIAS}$ . If the EN pin voltage  $> 0.9$  V the device is guaranteed to be enabled. The NCP136 regulates the output voltage and the active discharge transistor is turned off. The EN pin has internal pull-down

current source with typ. value of 0.3  $\mu$ A which assures that the device is turned off when the EN pin is not connected.

## Current Limitation

The internal Current Limitation circuitry allows the device to supply the full nominal current and surges but protects the device against Current Overload or Short.

## Thermal Protection

Internal thermal shutdown (TSD) circuitry is provided to protect the integrated circuit in the event that the maximum junction temperature is exceeded. When TSD activated, the regulator output turns off. When cooling down under the low temperature threshold, device output is activated again. This TSD feature is provided to prevent failures from accidental overheating.

Activation of the thermal protection circuit indicates excessive power dissipation or inadequate heatsinking. For reliable operation, junction temperature should be limited to +105°C maximum.

## ORDERING INFORMATION

Device	Nominal Output Voltage	Marking	Option	Package	Shipping†
NCP136AFCT080T2G	0.80 V	7A	Output Active Discharge, Normal Turn-On Slew Rate	WLCSP6 Case 567XK (Pb-Free)	5000 / Tape & Reel
NCP136BFCT080T2G	0.80 V	7H	Non – Active Discharge, Normal Turn-On Slew Rate		
NCP136AFCT088T2G	0.88 V	7J	Output Active Discharge, Normal Turn-On Slew Rate		
NCP136AFCT105T2G	1.05 V	7K	Output Active Discharge, Normal Turn-On Slew Rate		
NCP136AFCT110T2G	1.10 V	7L	Output Active Discharge, Normal Turn-On Slew Rate		
NCP136AFCT120T2G	1.20 V	7E	Output Active Discharge, Normal Turn-On Slew Rate		
NCP136CFCT120T2G	1.20 V	7C	Output Active Discharge, Slow Turn-On Slew Rate		
NCP136AFCRC040T2G	0.40 V	7M	Output Active Discharge, Normal Turn-On Slew Rate Back Side Coating	WLCSP6 Case 567YU (Pb-Free)	5000 / Tape & Reel
NCP136AFCRC080T2G	0.80 V	7A	Output Active Discharge, Normal Turn-On Slew Rate Back Side Coating		

†For information on tape and reel specifications, including part orientation and tape sizes, please refer to our Tape and Reel Packaging Specifications Brochure, BRD8011/D.

To order other package and voltage variants, please contact your ON Semiconductor sales representative.



**WLCSP6 1.4x0.8x0.33**  
CASE 567XK  
ISSUE O

DATE 15 JAN 2019

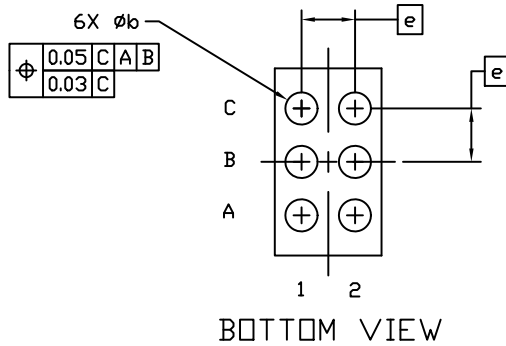
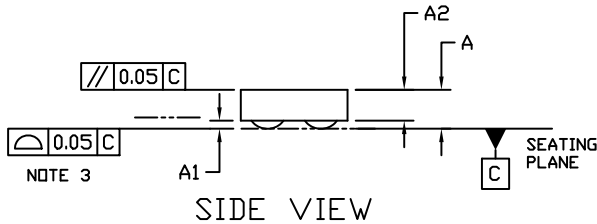
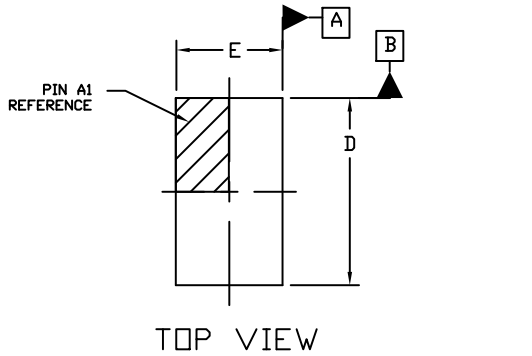

NOTES:

1. DIMENSIONING AND TOLERANCING PER ASME Y14.5M, 1994.
2. CONTROLLING DIMENSION: MILLIMETERS
3. COPLANARITY APPLIES TO THE SPHERICAL CROWNS OF THE SOLDER BALLS.

DIM	MILLIMETERS		
	MIN.	NOM.	MAX.
A	---	---	0.33
A1	0.040	0.060	0.080
A2	0.23 REF		
b	0.220	0.240	0.260
D	1.370	1.400	1.430
E	0.770	0.800	0.830
e	0.40 BSC		

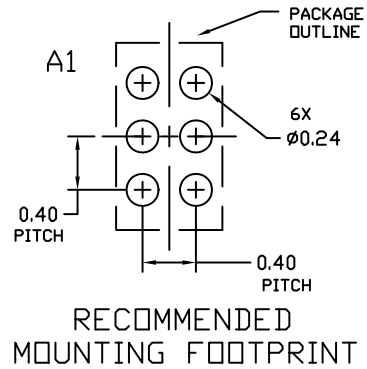

**GENERIC MARKING DIAGRAM\***



XX = Specific Device Code  
M = Month Code

\*This information is generic. Please refer to device data sheet for actual part marking. Pb-Free indicator, "G" or microdot "μ", may or may not be present. Some products may not follow the Generic Marking.

<b>DOCUMENT NUMBER:</b>	<b>98AON03100H</b>	Electronic versions are uncontrolled except when accessed directly from the Document Repository. Printed versions are uncontrolled except when stamped "CONTROLLED COPY" in red.
<b>DESCRIPTION:</b>	<b>WLCSP6 1.4x0.8x0.33</b>	<b>PAGE 1 OF 1</b>

ON Semiconductor and are trademarks of Semiconductor Components Industries, LLC dba ON Semiconductor or its subsidiaries in the United States and/or other countries. ON Semiconductor reserves the right to make changes without further notice to any products herein. ON Semiconductor makes no warranty, representation or guarantee regarding the suitability of its products for any particular purpose, nor does ON Semiconductor assume any liability arising out of the application or use of any product or circuit, and specifically disclaims any and all liability, including without limitation special, consequential or incidental damages. ON Semiconductor does not convey any license under its patent rights nor the rights of others.



**WLCSP6 1.4x0.8x0.37**  
**CASE 567YU**  
**ISSUE O**

DATE 14 NOV 2019

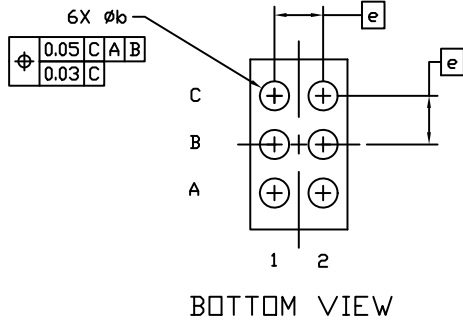
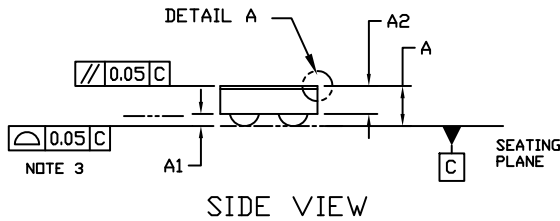
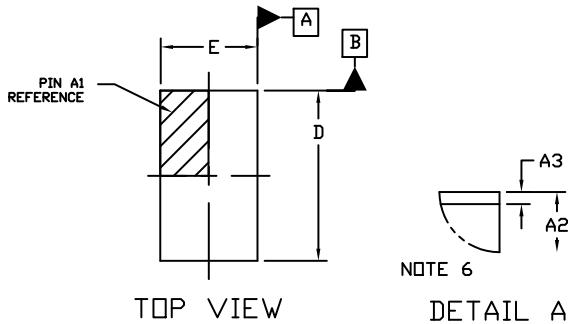

**GENERIC MARKING DIAGRAM\***



XX = Specific Device Code  
 M = Month Code

\*This information is generic. Please refer to device data sheet for actual part marking. Pb-Free indicator, "G" or microdot "•", may or may not be present. Some products may not follow the Generic Marking.

**NOTES:**

1. DIMENSIONING AND TOLERANCING PER ASME Y14.5M, 1994.
2. CONTROLLING DIMENSION: MILLIMETERS
3. COPLANARITY APPLIES TO THE SPHERICAL CROWNS OF THE SOLDER BALLS.
4. DATUM C, THE SEATING PLANE, IS DEFINED BY THE SPHERICAL CROWNS OF THE SOLDER BALLS.
5. DIMENSION b IS MEASURED AT THE MAXIMUM SOLDER BALL DIAMETER PARALLEL TO DATUM C.
6. BACKSIDE COATING IS OPTIONAL.

DIM	MILLIMETERS		
	MIN.	NOM.	MAX.
A	---	0.330	0.370
A1	0.080	0.100	0.120
A2	0.230 REF		
A3	0.020	0.025	0.030
b	0.220	0.240	0.260
D	1.370	1.400	1.430
E	0.770	0.800	0.830
e	0.400 BSC		

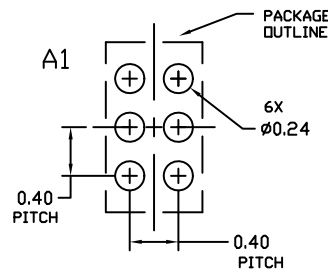

**RECOMMENDED MOUNTING FOOTPRINT**

\* For additional information on our Pb-Free strategy and soldering details, please download the ON Semiconductor Soldering and Mounting Techniques Reference Manual, SOLDERRM/D.

<b>DOCUMENT NUMBER:</b>	<b>98AON14943H</b>	Electronic versions are uncontrolled except when accessed directly from the Document Repository. Printed versions are uncontrolled except when stamped "CONTROLLED COPY" in red.
<b>DESCRIPTION:</b>	<b>WLCSP6 1.4x0.8x0.37</b>	<b>PAGE 1 OF 1</b>

ON Semiconductor and ON are trademarks of Semiconductor Components Industries, LLC dba ON Semiconductor or its subsidiaries in the United States and/or other countries. ON Semiconductor reserves the right to make changes without further notice to any products herein. ON Semiconductor makes no warranty, representation or guarantee regarding the suitability of its products for any particular purpose, nor does ON Semiconductor assume any liability arising out of the application or use of any product or circuit, and specifically disclaims any and all liability, including without limitation special, consequential or incidental damages. ON Semiconductor does not convey any license under its patent rights nor the rights of others.

ON Semiconductor and  are trademarks of Semiconductor Components Industries, LLC dba ON Semiconductor or its subsidiaries in the United States and/or other countries. ON Semiconductor owns the rights to a number of patents, trademarks, copyrights, trade secrets, and other intellectual property. A listing of ON Semiconductor's product/patent coverage may be accessed at [www.onsemi.com/site/pdf/Patent-Marking.pdf](http://www.onsemi.com/site/pdf/Patent-Marking.pdf). ON Semiconductor reserves the right to make changes without further notice to any products herein. ON Semiconductor makes no warranty, representation or guarantee regarding the suitability of its products for any particular purpose, nor does ON Semiconductor assume any liability arising out of the application or use of any product or circuit, and specifically disclaims any and all liability, including without limitation special, consequential or incidental damages. Buyer is responsible for its products and applications using ON Semiconductor products, including compliance with all laws, regulations and safety requirements or standards, regardless of any support or applications information provided by ON Semiconductor. "Typical" parameters which may be provided in ON Semiconductor data sheets and/or specifications can and do vary in different applications and actual performance may vary over time. All operating parameters, including "Typicals" must be validated for each customer application by customer's technical experts. ON Semiconductor does not convey any license under its patent rights nor the rights of others. ON Semiconductor products are not designed, intended, or authorized for use as a critical component in life support systems or any FDA Class 3 medical devices or medical devices with a same or similar classification in a foreign jurisdiction or any devices intended for implantation in the human body. Should Buyer purchase or use ON Semiconductor products for any such unintended or unauthorized application, Buyer shall indemnify and hold ON Semiconductor and its officers, employees, subsidiaries, affiliates, and distributors harmless against all claims, costs, damages, and expenses, and reasonable attorney fees arising out of, directly or indirectly, any claim of personal injury or death associated with such unintended or unauthorized use, even if such claim alleges that ON Semiconductor was negligent regarding the design or manufacture of the part. ON Semiconductor is an Equal Opportunity/Affirmative Action Employer. This literature is subject to all applicable copyright laws and is not for resale in any manner.

## PUBLICATION ORDERING INFORMATION

### LITERATURE FULFILLMENT:

Email Requests to: [orderlit@onsemi.com](mailto:orderlit@onsemi.com)

ON Semiconductor Website: [www.onsemi.com](http://www.onsemi.com)

### TECHNICAL SUPPORT

North American Technical Support:  
Voice Mail: 1 800-282-9855 Toll Free USA/Canada  
Phone: 011 421 33 790 2910

### Europe, Middle East and Africa Technical Support:

Phone: 00421 33 790 2910

For additional information, please contact your local Sales Representative