

Compact, Enclosed Limit Switch

- Connector-ready for quick replacement
- New center roller lever model for compact installation and gang mounting
- Triple-seal construction meets UL Types 3, 4, and 13
- Panel-mount types available
- Microchange™ connector cordsets available
- UL/CSA approvals



Ordering Information

■ LIMIT SWITCHES

Actuator	Part Number	
	1 A at 125 VAC	1 A at 30 VDC
Pin plunger	D4CC-1001	D4CC-3001
Roller plunger	D4CC-1002	D4CC-3002
Cross roller plunger	D4CC-1003	D4CC-3003
Bevel plunger	D4CC-1010	D4CC-3010
Low operating force roller lever	D4CC-1024	D4CC-3024
Sealed plunger	D4CC-1031	D4CC-3031
Sealed roller plunger	D4CC-1032	D4CC-3032
Sealed cross roller plunger	D4CC-1033	D4CC-3033
Panel mount pin plunger	D4CC-1041	D4CC-3041
Panel mount roller plunger	D4CC-1042	D4CC-3042
Panel mount cross roller plunger	D4CC-1043	D4CC-3043
Plastic rod	D4CC-1050	D4CC-3050
Center roller lever	D4CC-1060	D4CC-3060

MicroChange—Reg TM Woodhead Industries

Part Numbers for LED Models:

AC: Substitute a number **2** for the number **1** in the Part Number. Example: D4CC-2001

DC: Substitute a number **4** for the number **3** in the Part Number. Example: D4CC-4001

■ ACCESSORIES

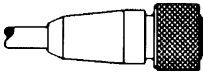
Description		Part number	
Connector cordsets, with straight connector, 4-conductor 	For AC limit switches	2 m (6.56 ft) cable length	XS2F-A421-D90-A
		5 m (16.40 ft) cable length	XS2F-A421-G90-A
	For DC limit switches	2 m (6.56 ft) cable length	XS2F-D421-D80-A
		5 m (16.40 ft) cable length	XS2F-D421-G80-A
Panel mounting adapters to replace standard size (WL) limit switches with D4CC		For D4CC-□001	D4CC-P001
		For D4CC-□002	D4CC-P002
		For D4CC-□020	D4CC-P020

Construction

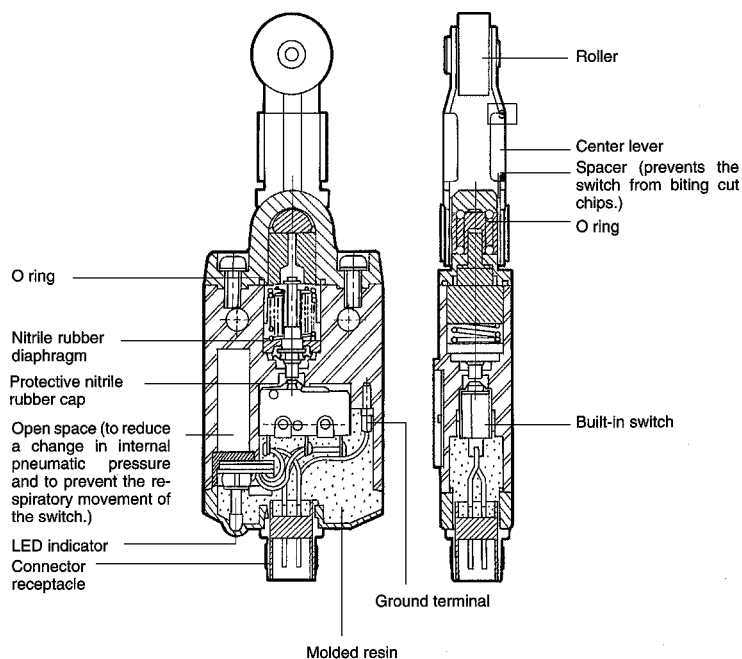

Specifications

■ RATINGS

Rated voltage	Non-inductive load (A)				Inductive load (A)				Inrush current (A)	
	Resistive load		Lamp load		Inductive load		Motor load		NC	NO
	NC	NO	NC	NO	NC	NO	NC	NO		
125 VAC	1 A	1 A	1 A	0.7 A	1 A	1 A	1 A	1 A	5 A	2.5 max.
30 VDC	1 A	1 A	1 A	1 A	1 A	1 A	1 A			

- Note:
1. Inductive loads have a power factor of 0.4 min. (AC) and a time constant of 7 ms max. (DC).
 2. Lamp loads have an inrush current of 10 times the steady-state current.
 3. Motor loads have an inrush current of 6 times the steady-state current.

■ CHARACTERISTICS

Enclosure ratings	UL	Types 3, 4 and 13
	NEMA	Types 1, 3, 3R, 4, 5, 6, 12 and 13
	IEC 144	IP67
Mechanical life		10,000,000 operations min.
Ambient operating temperature		-10°C to 70°C (14°F to 158°F)
Vibration	Malfunction durability	10 to 55 Hz, 1.5 mm (0.06 in) double amplitude
Shock	Malfunction durability	Approx. 50 G
	Mechanical durability	Approx. 100 G

■ OPERATING CHARACTERISTICS

Legend: OF = Operating Force (max.); RF = Reset Force (min.); OT = Overtravel (min.); PT = Pretravel
MD = Movement Differential (max.); TT = Total Travel; OP = Operating Position

Part number	OF max.	RF min.	OT min.	PT max.	MD max.	TT	OP
D4CC-□001	1.2 kg (42.33 oz)	0.45 kg (15.87 oz)	3 mm (0.12 in)	1.8 mm (0.07 in)	0.2 mm (0.008 in)	1.8 mm (0.07 in)	15.7 ±1 mm (0.62 ±0.04 in)
D4CC-□002	1.2 kg (42.33 oz)	0.45 kg (15.87 oz)	3 mm (0.12 in)	1.8 mm (0.07 in)	0.2 mm (0.008 in)	1.8 mm (0.07 in)	28.5 ±1 mm (1.12 ±0.04 in)
D4CC-□003	1.2 kg (42.33 oz)	0.45 kg (15.87 oz)	3 mm (0.12 in)	1.8 mm (0.07 in)	0.2 mm (0.008 in)	1.8 mm (0.07 in)	28.5 ±1 mm (1.12 ±0.04 in)
D4CC-□010	1.2 kg (42.33 oz)	0.45 kg (15.87 oz)	3 mm (0.12 in)	1.8 mm (0.07 in)	0.2 mm (0.008 in)	1.8 mm (0.07 in)	28.5 ±1 mm (1.12 ±0.04 in)
D4CC-□024	0.58 kg (20.46 oz)	0.15 kg (5.29 oz)	50°	10°+3°	3°	10°+3°	—
D4CC-□031	1.8 kg (63.49 oz)	0.45 kg (15.87 oz)	3 mm (0.12 in)	1.8 mm (0.07 in)	0.2 mm (0.008 in)	5 mm (0.20 in)	24.9 ±1 mm (0.98 ±0.04 in)
D4CC-□032	1.8 kg (63.49 oz)	0.45 kg (15.87 oz)	3 mm (0.12 in)	1.8 mm (0.07 in)	0.2 mm (0.008 in)	5 mm (0.20 in)	34.3 ±1 mm (1.35 ±0.04 in)
D4CC-□033	1.8 kg (63.49 oz)	0.45 kg (15.87 oz)	3 mm (0.12 in)	1.8 mm (0.07 in)	0.2 mm (0.008 in)	5 mm (0.20 in)	34.3 ±1 mm (1.35 ±0.04 in)
D4CC-□041	1.2 kg (42.33 oz)	0.45 kg (15.87 oz)	3 mm (0.12 in)	1.8 mm (0.07 in)	0.2 mm (0.008 in)	5 mm (0.20 in)	31.2 ±1 mm (1.23 ±0.04 in)
D4CC-□042	1.2 kg (42.33 oz)	0.45 kg (15.87 oz)	3 mm (0.12 in)	1.8 mm (0.07 in)	0.2 mm (0.008 in)	5 mm (0.20 in)	36.8 ±1 mm (1.45 ±0.04 in)
D4CC-□043	1.2 kg (42.33 oz)	0.45 kg (15.87 oz)	3 mm (0.12 in)	1.8 mm (0.07 in)	0.2 mm (0.008 in)	5 mm (0.20 in)	36.8 ±1 mm (1.45 ±0.04 in)
D4CC-□050	0.15 kg (5.29 oz)	—	—	15°	—	—	—
D4CC-□060	0.68 kg (23.99 oz)	0.15 kg (5.29 oz)	50°	10°+3°	3°	—	—

Engineering Data

■ ELECTRICAL SERVICE LIFE

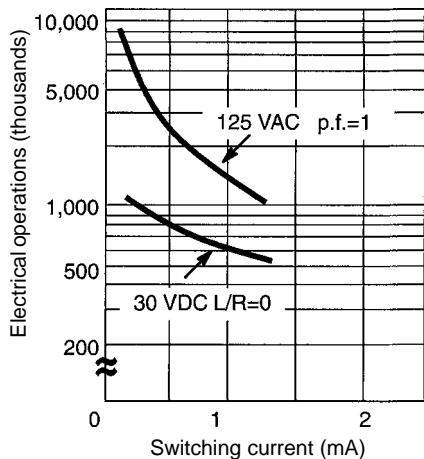

■ CONTACT RATINGS

NEMA B300

■ CONTACT RESISTANCE

100 mΩ

■ ELECTRICAL APPROVALS

UL Recognized, File No. E76675
 CSA Certified, File No. LR45746

Note: Approvals pending for DC types

Operation

■ CONTACT FORM

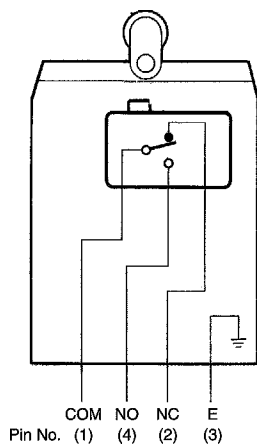

Connector pin

AC type

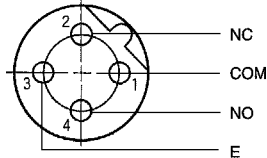

DC type

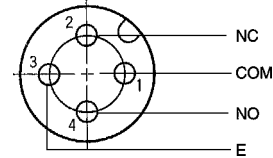

Dimensions

Unit: mm (inch)

■ LIMIT SWITCHES

Plunger Switches D4CC-□001

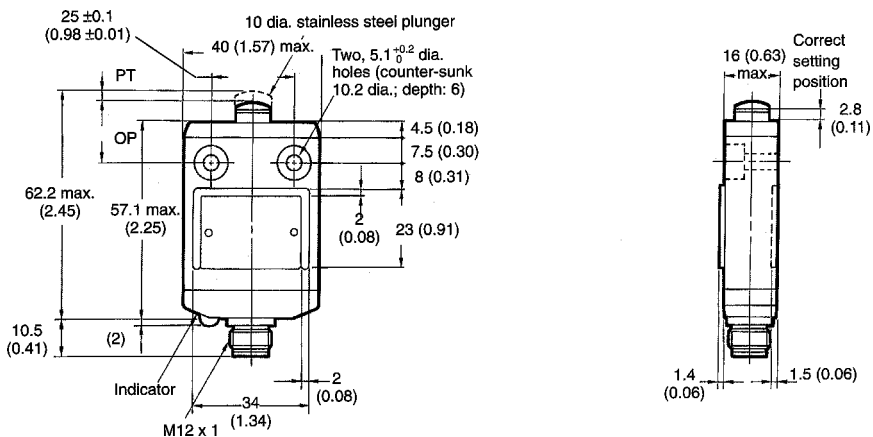

Unit: mm (inch)

Roller Lever Switches
D4CC-□024

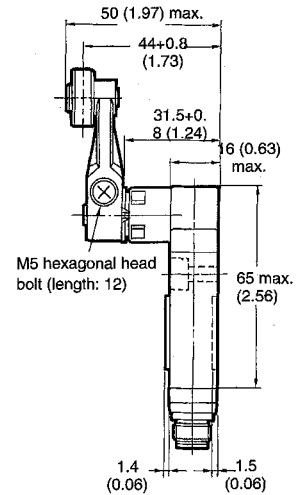
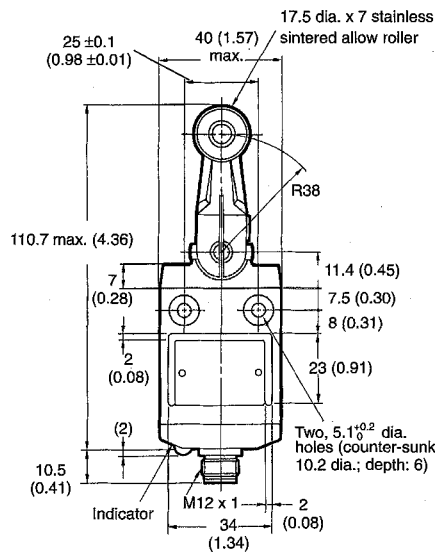
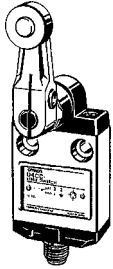

Sealed Plunger Switches
D4CC-□031

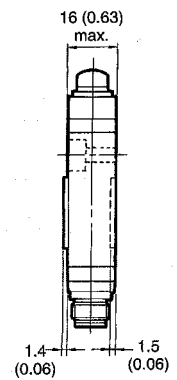
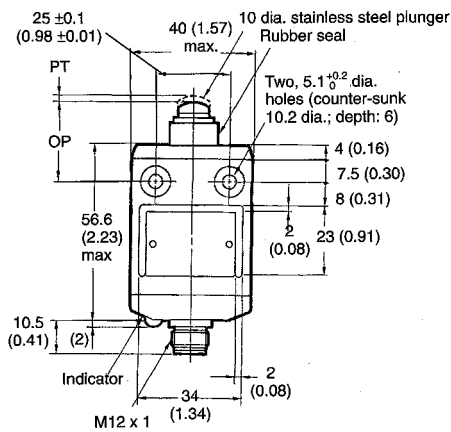

Sealed Roller Plunger Switches
D4CC-□032

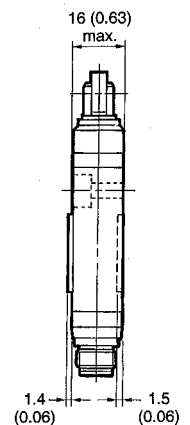
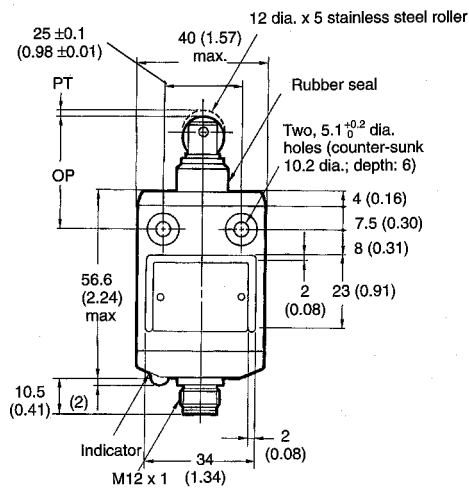
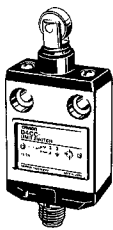

Sealed Cross Roller Plunger Switches
D4CC-□033

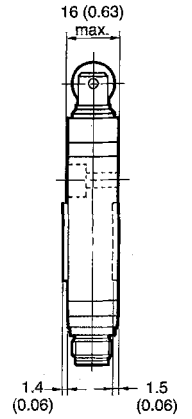
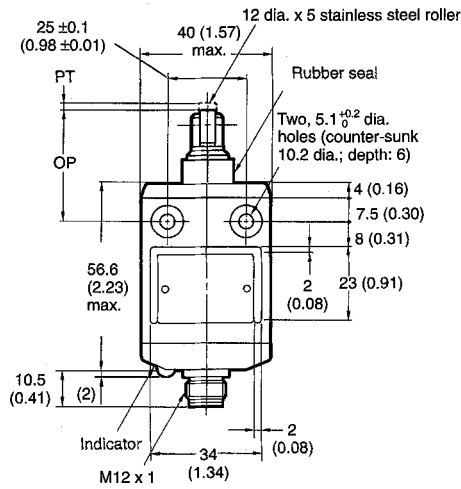
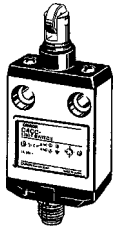

Panel-Mount Pin Plunger Switches
D4CC-□041

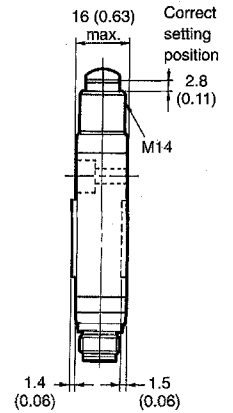
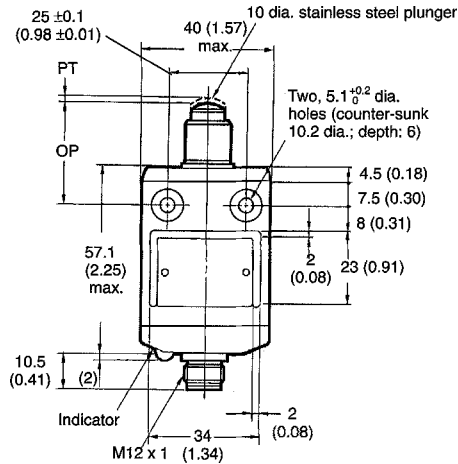
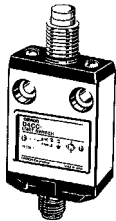

Panel-Mount Roller Plunger Switches
D4CC-□042

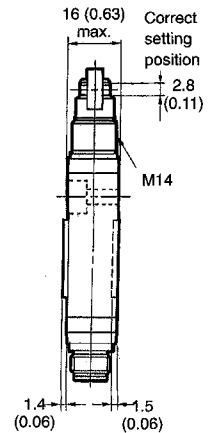
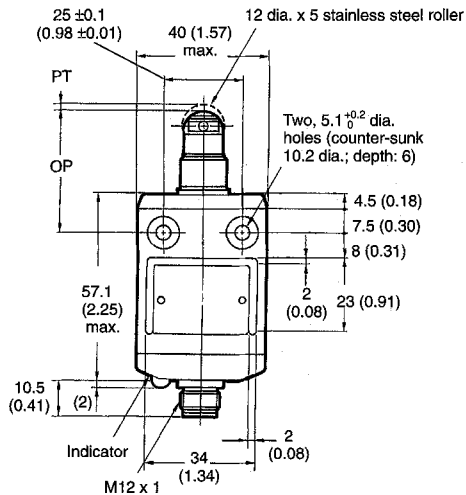
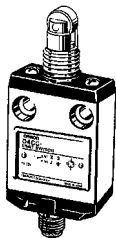

Unit: mm (inch)

**Panel-Mount Cross Roller Switches
D4CC-□043**

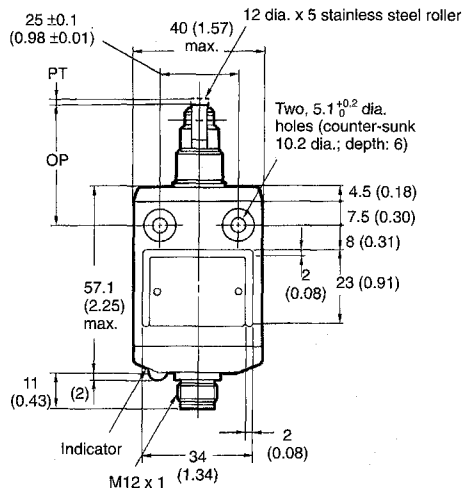
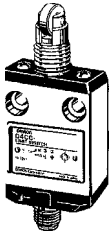

**Plastic Rod Switches
D4CC-□050**

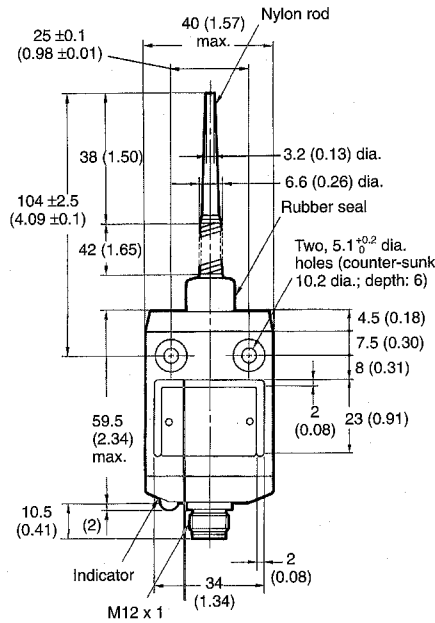
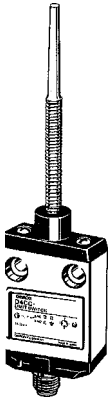

**Center Roller Lever Switches
D4CC-□060**

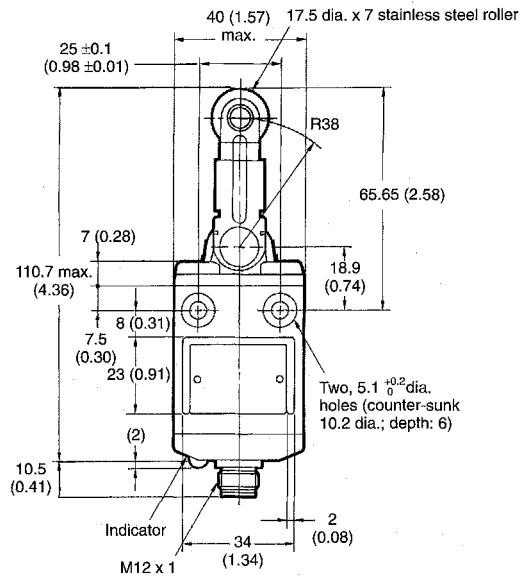
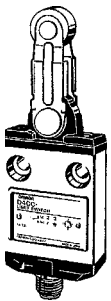

■ CONNECTOR CABLES

Y96E-44SA□(AC)

AC Type

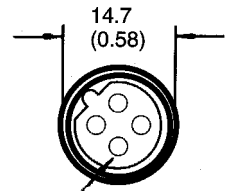
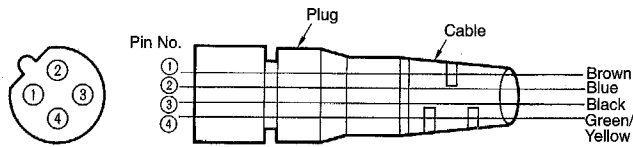

Silver-plated copper contacts

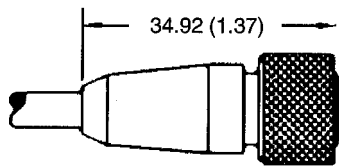

Y96E-44SD□(DC)

DC Type

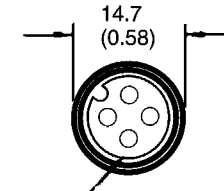
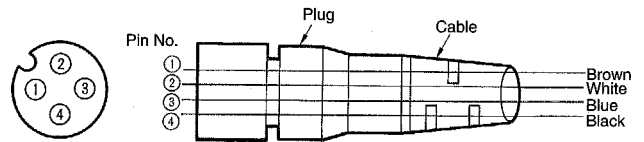

Silver-plated copper contacts

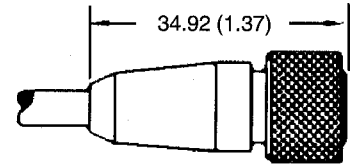

■ SPECIAL MOUNTING PLATES

D4C-P001 (For D4CC-□001)

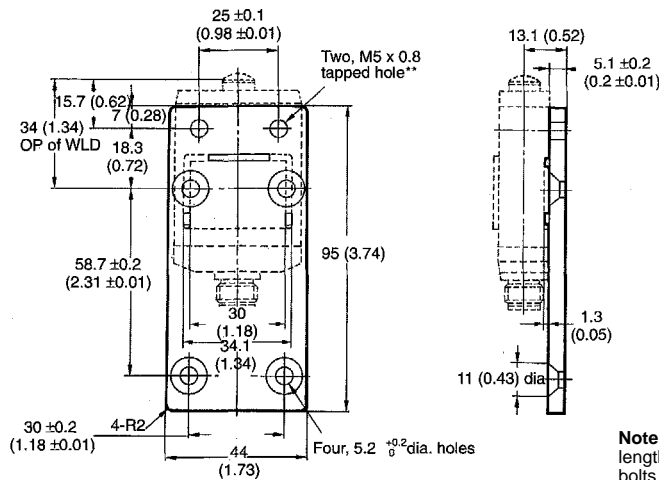
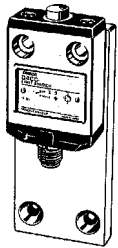

Note: Four hexagonal flat head bolts (M5 x 0.8, length: 10) and two hexagonal head bolts (M5 x 0.8, length: 15) are included.
 *All the holes with 5.2±0.2/0 dia. must be used with M5 x 10 hexagonal head bolts.
 **All the M5-tapped holes must be used with M5 hexagonal flat head bolts.

D4C-P002 (For D4CC-□002)

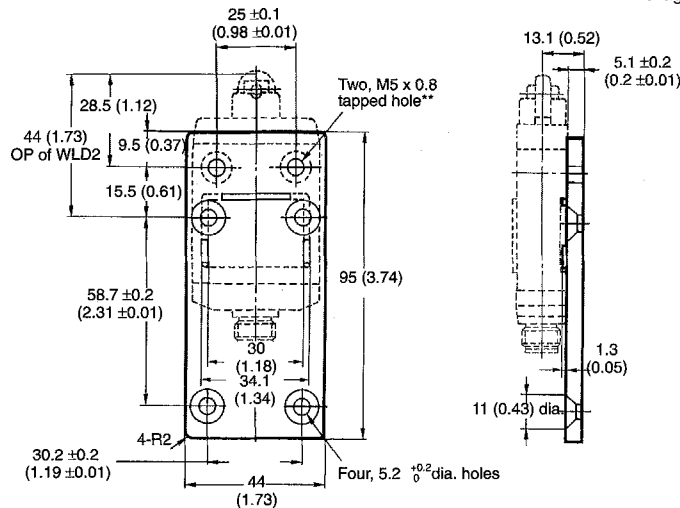
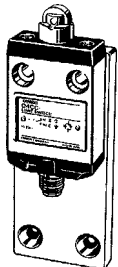

Unit: mm (inch)

D4C-P020 (For D4CC-□020)

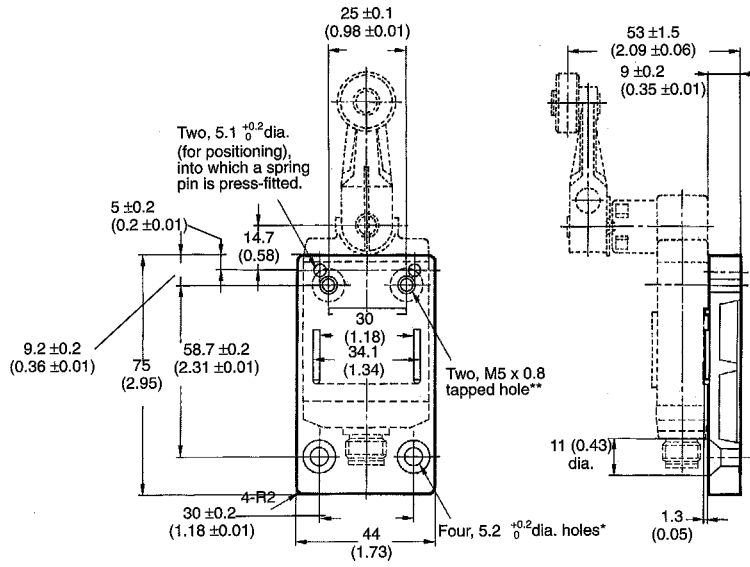
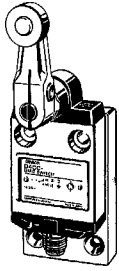

Note: Four hexagonal flat head bolts (M5 x 0.8, length: 10) and two hexagonal head bolts (M5 x 0.8, length: 15) are included.
 *All the holes with $5.2^{+0.2}_0$ dia. must be used with M5 x 10 hexagonal head bolts.
 **All the M5-tapped holes must be used with M5 hexagonal flat head bolts.

Installation

■ MOUNTING HOLES

Secure the switch to the mounting panel with M5 hexagonal head bolts and washers with a tightening torque of 50 to 60 kg•cm (34.4 to 41.3 in•lbs).

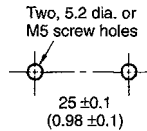

■ GANG MOUNTING SWITCHES

A maximum of six switches can be gang mounted. In this case, the convex part of the gang-mount guide on a switch must fit into the concave part of the guide on another switch as shown in the figure. A mounting panel with a thickness of 6 mm min. should be used.

The D4CC is designed so that gang mounted switches are physically secure to one another.

Secure the head of a D4CC Limit Switch with a tightening torque of 3.5 to 4.5 kg•cm (2.4 to 3.1 in•lbs) after changing the position of the head.

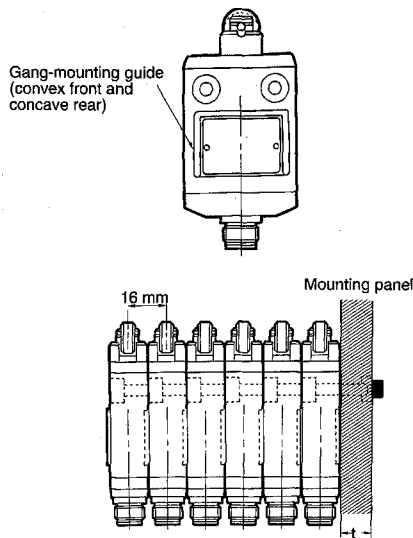

■ OPERATION

The method and frequency of operation, the shape of the cam and dog, and the overtravel value have a significant influence on the service life and precision of a D4CC Limit Switch. For this reason, the dog angle must be 30° max.; the surface roughness of the dog must be 6.3 microns max.; and, the hardness of the dog must be about Hv450.

To allow the plunger actuator to travel properly, adjust the position of the pin, roller, or bevel plunger with the dog or cam stroke so that the plunger is displaced to the groove part of the plunger (correct setting position) properly.

To allow the roller lever actuator to travel properly, adjust the position of the lever with the dog or cam stroke so that the arrowhead of the lever is positioned between the two convex markers as shown. The arrowhead indicates the proper stroke travel.

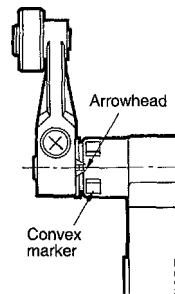

To allow the center roller lever actuator to travel properly, adjust the position of the lever with the dog or cam stroke so that part A (the convex part) of the lever is positioned in the convex part of the head.

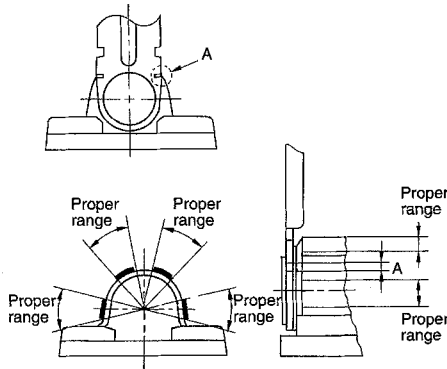

Refer to the following figure to set the stroke of a D4CC Limit Switch mounted on a panel.

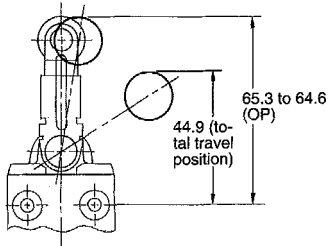

The bottom of the enclosed switch at the cable outlet is resin-molded. Secure the cable at a point 5 cm from the switch bottom to prevent exertion of excess force on the cable.

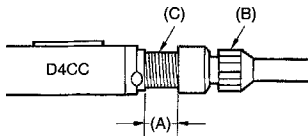

Turn screw B clockwise by hand to secure it with part C so that part C is covered with screw B until the width of A is nearly zero. If the tightening force is not enough, the screw can be loosened by vibration. Do not use pliers to tighten the screw, or the connector could be broken. Always tighten the screw securely by hand.

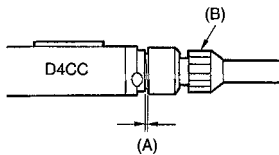

■ ENVIRONMENT

Avoid using D4CC Limit Switches in steamy places or where subject to hot water (70°C or higher).

■ SPECIAL MOUNTING PLATE

The D4CC is a SPDT limit switch for standard loads. The WLA_ cannot be replaced with a D4CC Limit Switch since the WLA_ contacts are normally open.

There is no difference in dimension between the mounting holes of the WL and those of the D4CC. The D4CC is, however, thinner than the WL model. Thus space can be saved if WL Limit Switches are replaced with D4CC Limit Switches mounted on Special Mounting Plates.

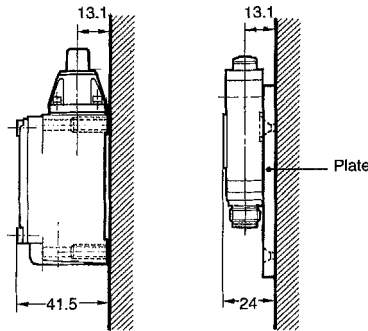

NOTE: DIMENSIONS ARE SHOWN IN MILLIMETERS. To convert millimeters to inches divide by 25.4.

OMRON

OMRON ELECTRONICS, INC.

One East Commerce Drive
Schaumburg, IL 60173
1-800-55-OMRON

OMRON CANADA, INC.

885 Milner Avenue
Scarborough, Ontario M1B 5V8
416-286-6465