

Optimum Sensor for Detecting Transparent Glass and Plastic Bottles

- Detects clear bottles reliably, even with “lens” effect
- Narrow, precise beam for accurate sensing
- Advanced optics for enhanced reliability
- Range 3’3” (1 m)
- Visible red LED for easy alignment
- Water-tight IP67 (NEMA 6P)
- Rugged die-cast metal housing
- 10-30 VDC
- Versatile NPN, PNP, L.O., D.O., in one unit



Ordering Information

■ CLEAR GLASS SENSORS

Connections	Supply voltage	Sensing type	Sensing distance		Output		Part number
			w/E39-R1	w/E39-R6	Type	Mode	
M12 quick disconnect	10 to 30 VDC ripple 10% max.	Retroreflective	1 meter	250 mm	NPN and PNP, switch selectable	L.O. and D.O., switch selectable	E3S-CR67
2-m attached cable							E3S-CR62

■ ACCESSORIES

Description	Range		Part number
Cables	2 m, 1-connector	3 conductors	XS2F-D421-DC0-A
	5 m, 1-connector	3 conductors	XS2F-D421-GC0-A
Reflector	1 meter		E39-R1
Mounting bracket			E39-L87

■ REPLACEMENT PARTS

Description	Part number
Reflector included with sensor	E39-R6
Mounting bracket included with sensor	E39-L113

Specifications

Part number		E3S-CR67	E3S-CR62
Method of detection		Retroreflective	
Supply voltage		10 to 30 VDC ripple 10% max.	
Current consumption		40 mA	
Sensing distance	w/E39-R6 reflector (included)	250 mm, for closely-spaced bottles	
	w/E39-R1 reflector (optional)	1 meter, for widely-spaced bottles	
Object size		30 mm dia. x 150 long glass tube, 1.8 mm wall thickness	
Light source		Red LED (670 nm)	
Mode		L.O. and D.O., switch selectable	
Sensitivity adjustment		2-turn potentiometer	
Output		NPN and PNP, switch selectable	
Capacity		30 VDC, 100 mA; residual voltage, NPN 1.2 V, PNP 2.0 V	
Response time		1 ms on, 1 ms off	
Circuit protection		Reverse polarity and short circuit protection	
Indicators		Red: light received, Green: stability	
Material	Case	Die-cast zinc	
	Panel	Sulfonated polyether	
	Lens	Acrylic	
	Bracket	Stainless steel	
Connection		M12 quick disconnect	2-m attached cable
Weight		80 g	115 g
Cable bending radius		—	25 mm min.
Enclosure rating		IP67 NEMA 6P	
Ambient light immunity		Incandescent: 5,000 lx max.	
		Sunlight: 10,000 lx max.	
		Mutual interference protection (See Note.)	
Ambient operating temperature		-25°C to 55°C (-13°F to 131°F) no icing	
Relative operating humidity		35% to 85% RH	
Insulation resistance		20 MΩ min. at 500 VDC	
Dielectric strength		1,000 VAC, 50/60 Hz for 1 min.	
Vibration		10–2000 Hz, 1.5 mm double amplitude, or 300 m/s ² (approx. 30G) for 0.6 hours in X, Y, Z axes	
Shock resistance		1 m/s ² (approx, 100 G) 3 times, X, Y, Z axes	

Note: Mutual Interference Protection: Allows sensor to filter out interfering light sources from nearby sensors and avoid interference.

Engineering Data

REFLECTOR PARALLEL MOVEMENT (TYPICAL)

E3S-CR67/62 (E39-R6 Reflector included)

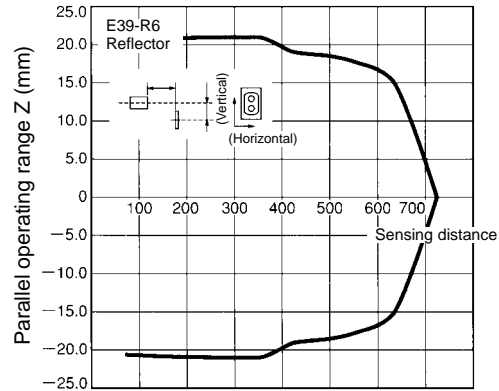
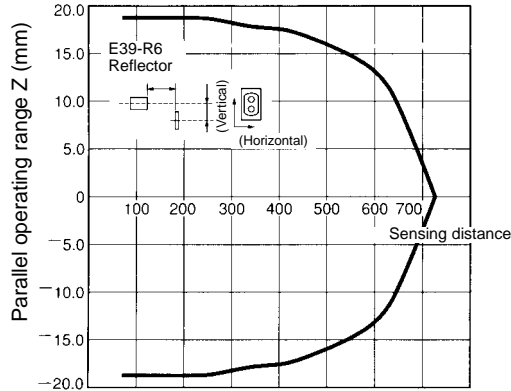

E3S-CR67/62 (optional E39-R1 Reflector)

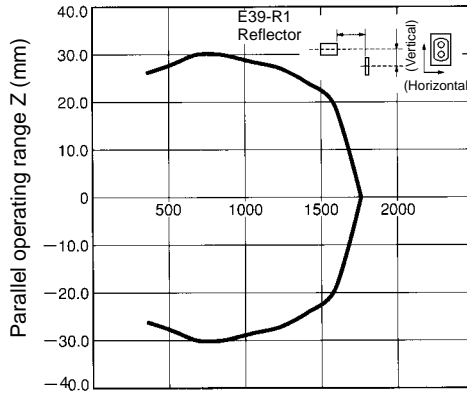
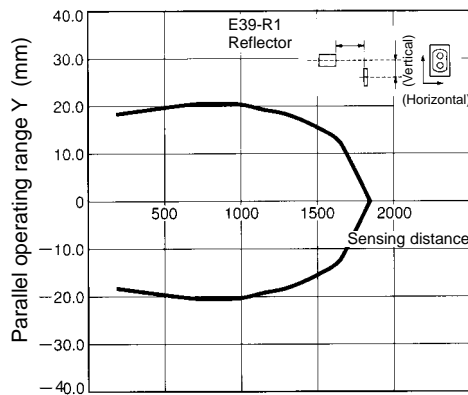

SET DISTANCE VS. EXCESS GAIN (TYPICAL)

E3S-CR67/62

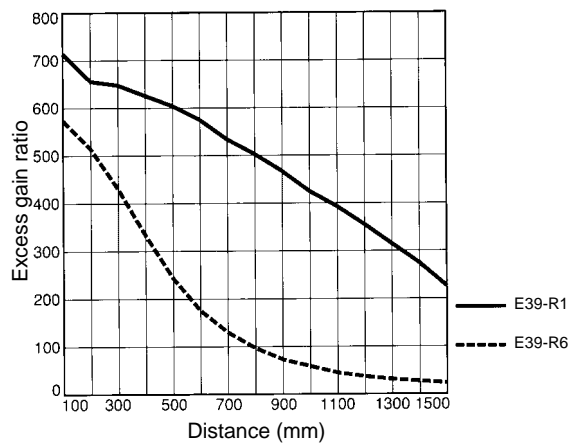

■ E3S-CD62

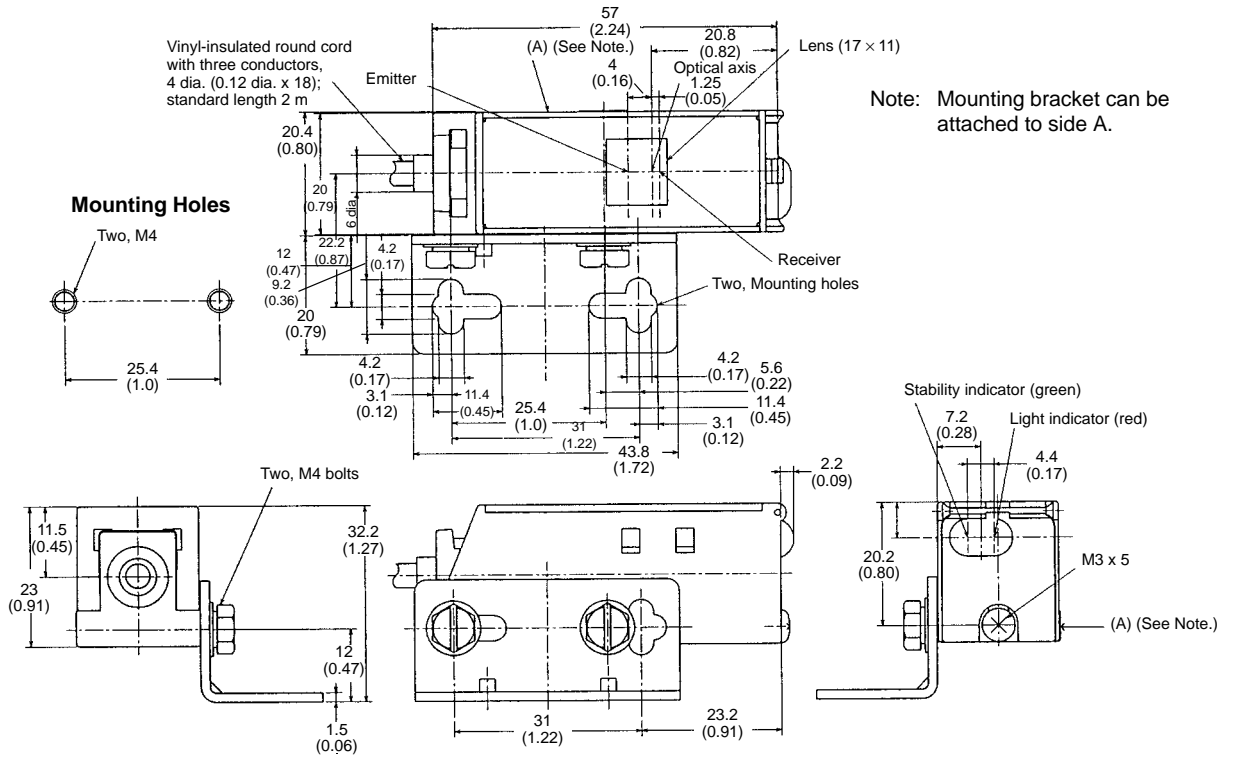

■ ACCESSORIES

E39-R1 Reflector

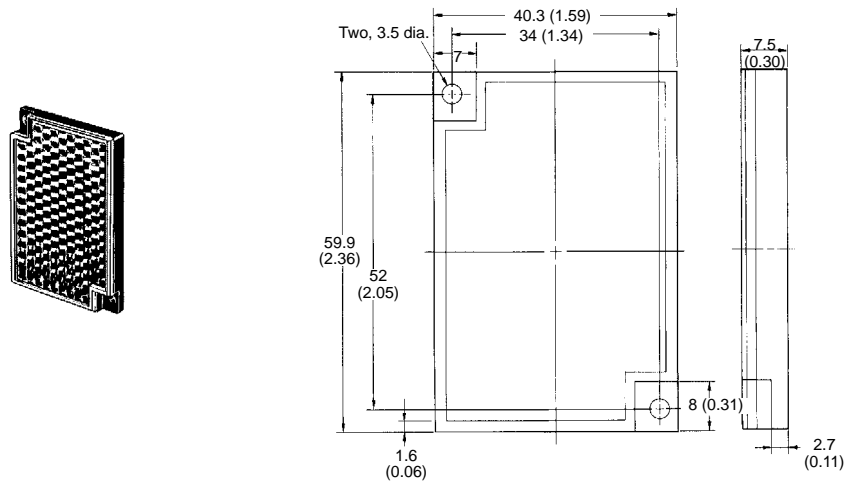

Installation

■ CONNECTIONS

Wiring Diagram (NPN Shown)

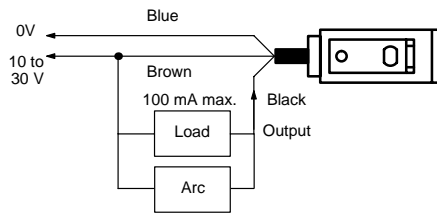

Note: If the load is a relay, insert arc suppressor across the coils of the relay.

With Sensor Controller (S3D2)

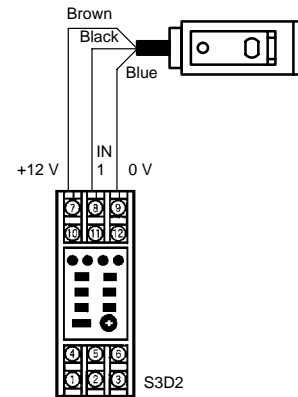

Nomenclature

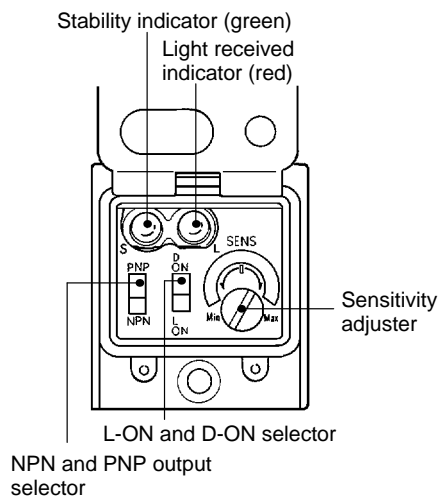

Operation Panel

Use the NPN and PNP output selector on the operation panel to select the type of output transistor.

Use the Light-ON and Dark-ON selector on the operation panel to select the operation mode of the E3S-CR67/62.

Operation

WIRING DIAGRAM

Output configuration	Mode switch	Output transistor	Output circuits
NPN	Light-ON	On when light is received.	
	Dark-ON	ON when light is not received.	
PNP	Light-ON	On when light is received.	
	Dark-ON	ON when light is not received.	

I/O Connector Plug

NPN Output

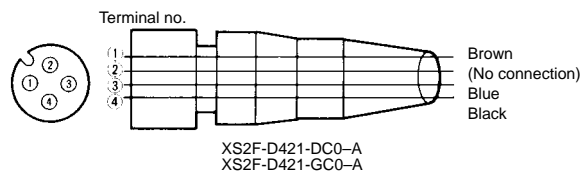

PNP Output

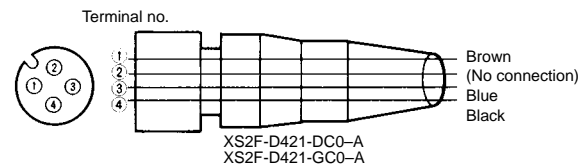

NPN output				PNP output			
Type	Conductor	Connector pin	Application	Type	Conductor	Connector pin	Application
DC	Brown	1	Power supply (+V)	DC	Brown	1	Power supply (+V)
	Black	4	Output		Black	4	Output
	Blue	3	Power supply (0 V)		Blue	3	Power supply (0 V)
	---	2	No connection		---	2	No connection

■ TIMING CHART

Output configuration	Mode switch	Output transistor	Timing chart
NPN	Light-ON	On when light is received.	
	Dark-ON	ON when light is not received.	
PNP	Light-ON	On when light is received.	
	Dark-ON	ON when light is not received.	

■ MUTUAL INTERFERENCE PROTECTION

If reflective Clear Glass Sensors are installed side by side, each one may be influenced by the light emitted from the other Clear Glass Sensors.

The fuzzy mutual interference prevention function of the E3S-CR67/62 enables the E3S-CR67/62 to monitor any light interference for a certain period before the E3S-CR67/62 starts emitting light so that the E3S-CR67/62 can retrieve the intensity and frequency of the light interference as data. Using this data, the E3S-CR67/62 estimates with fuzzy inference the risk of the malfunctioning of the E3S-CR67/62 and controls the timing of the E3S-CR67/62 light emission.

When the risk is low:

The E3S-CR67/62 waits until there is no light interference and emits light.

■ OPTICAL AXIS ADJUSTMENT

Move the Sensor and Reflector upwards, downwards, left, and right within areas respectively to locate the Sensor and Reflector in the center of each area where the red incident indicator is lit. Then check that the green stability indicator is lit.

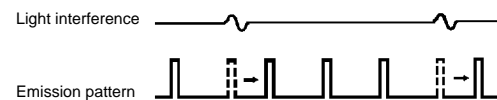



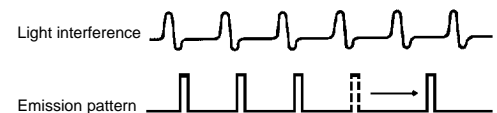

When the risk is high:

The E3S-CR67/62 emits light between each light interference moment.

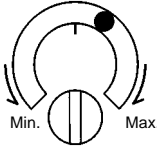
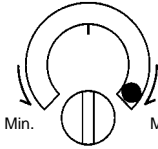

■ SENSITIVITY ADJUSTMENT

After optical axis adjustment, make the following sensitivity adjustment according to the type of sensing object.

Item	Transparent bottle or glass plate	Opaque object
Sensing condition	Without sensing object	With or without sensing object
Sensitivity adjuster		
Indicators	  STABILITY (green) LIGHT (red)	  STABILITY (green) LIGHT (red)
Procedure	Turn the sensitivity adjuster from minimum to maximum and set the sensitivity adjuster to the position where a stable condition can be obtained.	If the sensing object is larger than the reflector diameter, set the sensitivity adjuster to maximum. If the sensing object is the same or smaller than the lens diameter, turn the sensitivity adjuster from minimum to maximum to set the sensitivity adjuster to the position where a stable condition can be obtained.

Precautions

■ CONNECTION

If the input/output lines of the Clear Material Sensor are placed in the same conduit or duct as power lines or high-voltage lines, the Clear Material Sensor may malfunction, or be damaged by electrical noise. Either separate the wiring, or use shielded lines as input/output lines to the Clear Material Sensor.

The cable connected to the E3S-CR67/62 can be extended up to 100 m provided that the diameter of each wire of the cable is 0.3 mm² minimum.

■ STARTUP OPERATION

A maximum of 100 ms is required from the time power is turned on until the E3S-CR67/62 is able to detect objects. If power is supplied to the loads and the E3S-CR67/62 from different sources, turn on power to the E3S-CR67/62 first.

■ POWER SUPPLY

If a standard switching regulator is used as a power supply, the frame ground (FG) terminal and the ground (G) terminal must be grounded, or the E3S-CR67/62 may malfunction, due to the switching noise of the power supply.

If an inverter motor or servomotor is used with the E3S-CR67/62, the frame ground (FG) terminal and the ground (G) terminal must be grounded, or the E3S-CR67/62 may malfunction.

■ WATER RESISTANCE

Do not use the E3S-CR67/62 in water, in the rain, or outdoors.

To ensure the E3S-CR67/62 meets IP67 water resistance, tighten the screws of the operation panel cover to a torque of 3.5 to 5.5 kgf • cm (36.4 to 60.2 in • lb).

■ OIL AND CHEMICAL RESISTANCE

Do not use the E3S-CR67/62 in oils or liquid chemicals.

■ CABLE

The E3S-CR67/62 uses an oil-resistive cable to ensure oil resistance.

Do not allow the cable to be repeatedly bent during application.

Do not allow the cable to be bent to a radius of less than 25 mm.

■ MOUNTING

When mounting the E3S-CR67/62, avoid heavy impact (see shock and vibration specifications) which may damage sensor.

Use M4 screws to mount the E3S-CR67/62.

The tightening torque of each screw must be 12 kgf • m (124 in • lb) maximum.

Mounting Bracket

When mounting the E3S-CR67/62 with the mounting bracket so that sensing objects will be in the direction of the mechanical axis, use the optical axis lock holes.

If it is not possible to mount the E3S-CR67/62 so that the sensing objects will be in the direction of the mechanical axis, move the E3S-CR67/62 upwards, downwards, to the left, or to the right and secure the E3S-CR67/62 in the center of the range where the light indicator will be lit, at which time make sure that the stability indicator is lit.

Direct Mounting

Mount the E3S-CR67/62 as shown in the following illustration.

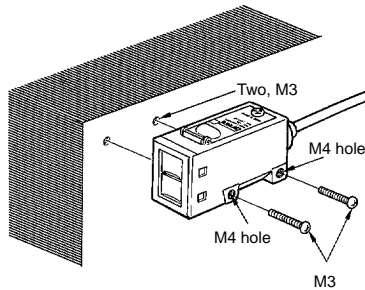
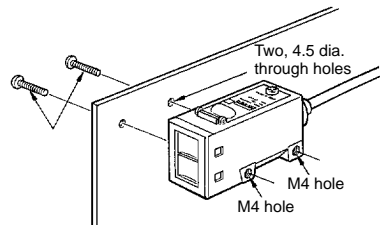

OPTICAL AXIS ADJUSTMENT

Direct the mounting axis of the mounting bracket in the direction where sensing objects will be located. The optical axis of the E3S-CR67/62 coincides with the mounting axis of the mounting bracket, which enables the user to adjust the optical axis of the E3S-CR67/62 with ease.

Optical Lock Holes

By tightening the optical axis lock holes with screws, the mounting bracket will be in the direction of the optical axis of the E3S-CR67/62.

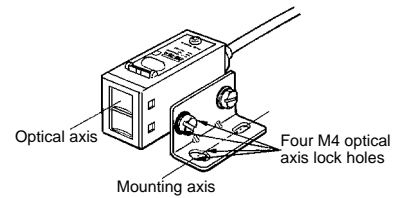

NOTE: DIMENSIONS SHOWN ARE IN MILLIMETERS. To convert millimeters to inches divide by 25.4.

OMRON[®]
OMRON ELECTRONICS, INC.
 One East Commerce Drive
 Schaumburg, IL 60173
1-800-55-OMRON

OMRON CANADA, INC.
 885 Milner Avenue
 Scarborough, Ontario M1B 5V8
416-286-6465