

Monitor the Output of a UV Light Source through a Fiber-Optic Cable

Monitors with Fiber Optics

- Head Unit withstands temperatures of up to 300°C
- Easy-to-read digital display of measurement values
- UV light converted to visible light (before performing measurements) prevents deterioration of the Amplifier's light-receiving element



Monitors with Built-in Amplifiers

- Deterioration due to UV light prevented by protective structure
- Confirm the output status of the UV light source with an operation indicator
- Filtering Cover also available (reduces light intensity by 1/6.5)



Ordering Information

■ MONITORS WITH BUILT-IN AMPLIFIERS

Main Unit

Appearance	Intensity range of incident light	Output	Part number
	1 to 30 mW/cm ²	Analog voltage output (1 to 5 V)	F3UV-A30
	0.2 to 3 mW/cm ²		F3UV-A03

Note: Does not function as a sensor.

■ MONITORS WITH OPTICAL FIBERS



Amplifier

Appearance	Connection method	Outputs	Transistor type	Part number
	Pre-wired cable	<ul style="list-style-type: none"> • Judgement output • Answer-back output • Analog current or voltage output 	NPN	F3UV-XW11
			PNP	F3UV-XW41

Head Unit





Appearance	Wavelength range of incident light	Max. temperature	Remarks	Part number
	200 to 370 nm	300°C (Use at temperatures below the Fiber Unit's rated operating temperature.)	Includes two M8 nuts and one mounting plate.	F3UV-HM

Fiber Units

Compatible Amplifier Units	Compatible Head Units	Appearance	Max. temperature	Intensity range of incident light (see note)	Quantity	Part number
F3UV-XW11, F3UV-XW41	F3UV-HM	 M4 threads, 2 m	300°C	10 to 300 mW/cm ²	1	F32-300
		 M4 threads, 2 m	70°C	10 to 300 mW/cm ²	1	F32-70

Note: The values given are for a standard UV light source with a central wavelength of 360 nm, measured with a standard illumination meter (and for use in combination with the specified Amplifier and Head Unit). The power range is one for which teaching to 100% is possible.

Accessories (Order Separately)**■ ACCESSORIES FOR MONITORS WITH BUILT-IN AMPLIFIERS**

Appearance	Description	Part number
	Protective tube (Protects the cord.)	F39-CU1M
	Protective cover (Protects the display.)	F39-HU2
	1/6.5 Filtering cover	F39-HU1
	Mounting bracket	F39-L9

■ ACCESSORIES FOR MONITORS WITH FIBER OPTIC CABLES

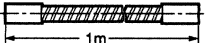
Appearance	Name	Quantity	Applicable Fiber Units	Part number
	Protective tube (Protects the fiber.)	1	F32-70	F39-FU1M

Specifications

■ RATINGS/CHARACTERISTICS

Monitors with Built-in Amplifiers (Main Unit)

Item	F3UV-A30	F3UV-A03
Incident light power range (See Note 1)	1 to 30 mW/cm ²	0.2 to 3 mW/cm ²
Incident light wavelength range	200 to 370 nm	
Power indicator	Green LED	
Operation indicator	Orange LED (lights with an output between 4 and 5 V)	
Sensitivity adjustment	One-turn potentiometer	
Power supply voltage	12 to 24 VDC ±10%	
Current consumption	15 mA max.	
Response time (See Note 2)	300 ms max.	400 ms max.
Output (See Note 3)	1 to 5 V (with an offset voltage of 0.2 V min.)	
Connection impedance	100 kΩ min.	
Repeatability	±2% Full Scale max.	
Temperature drift	0.2% of Full Scale/°C max.	
Ambient operating illumination (See Note 4)	Fluorescent light 1,000 lux max.	Fluorescent light 500 lux max.
Ambient temperature	Operating: -10° to 70°C (14° to 158°F) Storage: -25° to 80°C (-13° to 176° F)	
Ambient humidity	Operating: 35% to 85%	
Insulation resistance	20 MΩ min. (at 500 VDC)	
Dielectric strength	1,000 VAC 50/60 Hz for 1 min	
Vibration resistance	10 to 150 Hz, 0.1-mm amplitude in X, Y, and Z directions (8 minutes of vibration × 10 repetitions= total time of 80 minutes)	
Shock resistance	150 m/s ² three times each in the ±X, ±Y, and ±Z directions approximately 1.5 G	
Degree of protection	Conforms to IEC IP30	
Connection method	Pre-wired cable with a standard length of 2 m	
Weight (packed)	78 g (2.75 oz)	
Material	Casing: die-cast zinc Window: synthetic quartz glass	
Accessories	Operation Manual	

- Note:**
- Using a standard UV light source and UV illumination meter in a power range for which analog output can be set to 5 V.
 - The response time is the rise time of the output signal.
 - An output voltage up to 6 V can be output. Adjust the sensitivity so that the output is less than 5 V. The output is 0.2 to 1 V when there is no incident UV light.
 - This value is the illumination at the receiver window maintaining an offset voltage of 1 V max. with the fluorescent light.

■ ACCESSORIES (SOLD SEPARATELY)

Protective Tube (Protects the Cord.)

Item		F39-CU1M
		<p>The diagram shows a side view of the F39-CU1M protective tube. It consists of a central flexible tube section, 1 meter long, with a head connector on the left and an end cap on the right. The head connector and end cap are shown as rectangular blocks with circular openings. The flexible tube is shown with a textured, braided appearance.</p>
Ambient temperature		-40° to 100°C (-40° to 212°F) for operation and storage (Use within the specified operating temperature range of the Monitor.)
Ambient humidity		Operating: 35% to 85% Storage: 35% to 95%
Bending radius		24 ± 5 mm (94 ± 0.19 in)
Max. pulling force		2 N-m (1.47 ft. lbs.) max. between the head connector and tube, end cap and tube, or on the tube itself
Crush weight		9.8 N-m (7.2 ft. lbs.) max. load on the side of the tube
Material	Head connector	Nickel-plated brass
	End cap	
	Tube	Stainless (SUS304)
Attachment		M2 screws

Protective Tube (Protects the Fiber.)

Item		F39-FU1M
		<p>The diagram shows a side view of the F39-FU1M protective tube. It consists of a central flexible tube section, 1 meter long, with a head connector on the left and an end cap on the right. The head connector and end cap are shown as rectangular blocks with circular openings. The flexible tube is shown with a textured, braided appearance.</p>
Ambient temperature		-40° to 150°C (-40° to 302° F) for operation and storage (Keep the ambient temperature within the range specified for the fiber within the tube.)
Ambient humidity		Operating: 35 to 85% Storage: 35 to 95%
Bending radius		30 mm (1.18 in) min.
Max. pulling force		1.5 N-m (1.10 ft. lbs.) max. between the head connector and tube, 1.5 N-m (1.10 ft. lbs.) max. between the end cap and tube, and 2 N-m (1.47 ft. lbs.) on the tube itself
Crush weight		29.4 N-m (21.67 ft. lbs) max. on the tube
	Head connector	Nickel-plated brass
	End cap	
	Tube	Stainless (SUS304)

■ MONITORS WITH FIBER-OPTIC CABLES

Amplifiers

Item	F3UV-XW11	F3UV-XW41	
Power supply voltage	12 to 24 VDC \pm 10%		
Current consumption	75 mA max.		
Outputs	Analog output	Current (4 to 20 mA) or voltage (1 to 5 V) (Monitoring mode or integral mode)	
	Judgement output	NPN open collector output, 100 mA max., residual voltage 1 V max.	PNP open collector output, 100 mA max., residual voltage 2 V max.
	Answer-back output	(Monitoring mode or integral mode)	(Monitoring mode or integral mode)
Inputs	Remote teaching input	ON: 0 V short-circuit (current 1 mA max.)	ON: Power supply voltage short-circuit or 9 to 24 V (open-circuit current: 3 mA max.) OFF: Open (open or 1.5 V max.)
	Reset input	OFF: Open (open or 9 to 24 V)	
Protective circuits	Reversed power supply polarity protection and output short-circuit protection		
Response time (See Note 1)	500 ms max.		
Sensitivity setting	Teaching function		
Indicators	Power supply/Teaching indicator (green/red), Operation indicator (orange), 7-segment digital percentage display (red), 7-segment digital threshold display (red)		
Repetitive accuracy	\pm 2% Full Scale max.		
Ambient operating illumination (See Note 2)	Fluorescent light 1,000 lux max.		
Temperature drift	\pm 0.1% of Full Scale / $^{\circ}$ C max.		
Ambient temperature	Operating: -25° to 55° C (-13° to 131° F) with no icing or condensation Storage: -40° to 70° C (-40° to 158° F) with no icing or condensation		
Ambient humidity	Operating or storage: 35% to 85%		
Insulation resistance	20 M Ω min. (at 500 VDC)		
Dielectric strength	1,000 VAC 50/60 Hz between the leads and the case		
Vibration resistance	10 to 150 Hz, 0.1-mm amplitude or 15 m/s ² in X, Y, and Z directions each for 2 hours		
Shock resistance	150 m/s ² three times each in the X, Y, and Z directions		
Degree of protection	Conforms to IEC 60529 standards IP30		
Connection method	Pre-wired cable with a standard length of 2 m		
Weight (packed)	Approx. 270 g (9.5 oz)		
Material	ABS plastic		
Accessories	Operation Manual		

- Note:**
- The response time is the rise time or fall time of the output signal.
 - The ambient operating illumination is the illumination that changes the analog output +5% Full Scale at 200 lux; it is not the operational limit.
 - An analog output of up to 6 V (or 24 mA) can be output. The output is 1 V (or 4 mA) when there is no incident UV light.
 - For a current output, full scale is 16 mA (4 to 20 mA). For a voltage output, full scale is 4 V (1 to 5 V).
 - Definition of the luminous energy integral: The physical unit of the luminous energy integral is energy (J: joules) and this value is calculated by multiplying the UV intensity (mV) by the time of exposure (s), but it is dimensionless when this sensor's analog output value (V) is used for the UV intensity. The integral is measured with an 11 ms sampling time.

Head Unit

Item	F3UV-HM	
Incident light wavelength range	200 to 370 nm	
Temperature drift	0.15%/ $^{\circ}$ C max.	
Ambient temperature	Operating or storage: -40° to 300° C (-40° to 572° F) with no icing or condensation	
Ambient humidity	Operating or storage: 35% to 85% (with no icing or condensation)	
Weight (packed)	Approx. 300 g (10.58 oz.)	
Vibration resistance	10 to 55 Hz, 0.75-mm amplitude or 10 m/s ² , approximately 1 G	
Shock resistance	500 m/s ² approximately 50 G	
Material	Protective casing	Stainless steel (SUS303)
	Fluorescent fiber path	Functional fluoroglass
Accessories	M8 nut and mounting bracket	

Fiber Units

Item	Part number	
	F32-300	F32-70
Ambient temperature (See Note) (with no icing or condensation)	Operating: -40° to 300°C (-40° to 572° F) Storage: -40° to 110°C (-40° to 230° F)	Operating: -40° to 70°C (-40° to 158° F) Storage: -40° to 70°C (-40° to 158° F)
Ambient humidity (with no icing or condensation)	Operating: 35 to 85% Storage: 35 to 95%	
Bending radius	25 mm (0.98 in) min.	25 mm (0.98 in) min.
Fiber outer sheathing material	SUS	Black polyethylene
Degree of protection	Conforms to IEC IP67	
Standard fiber length	2 m	

Note: The maximum temperature is lower near the amplifier unit. See the Dimensions for details.

Engineering Data

MONITORS WITH BUILT-IN AMPLIFIERS

Output Characteristics

F3UV-A30

(Output characteristics when the output is set at 5 V for a UV intensity of 30 mW/cm².)

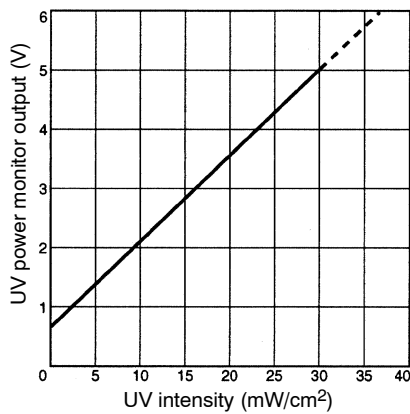

F3UV-A03

(Output characteristics when the output is set at 5 V for a UV intensity of 3 mW/cm².)

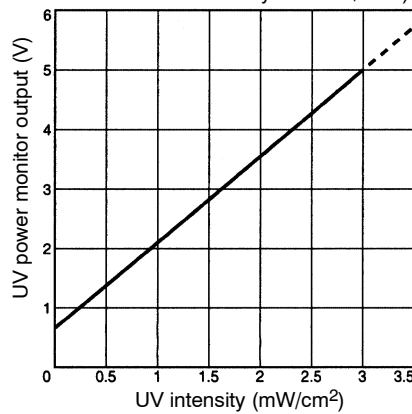

Angular Characteristics

F3UV-A30/-A03

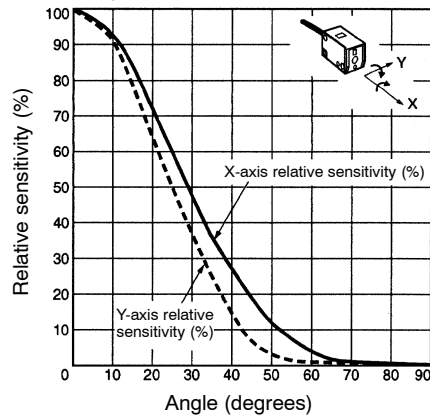

F3UV-A30/-A03 and F39-HU1 Cover (Sold Separately)

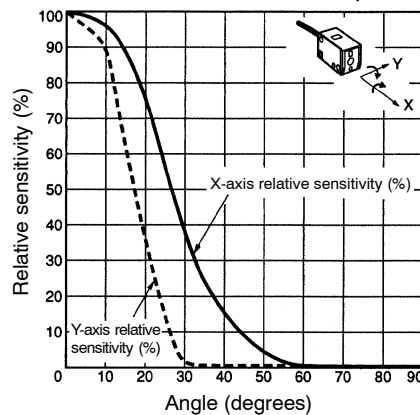

■ MONITORS WITH OPTICAL FIBERS

Output Characteristics

F3UV-XW□1 + F3UV-HM + F32-300

(Output characteristics when the sensitivity is set at 300 mW/cm².)

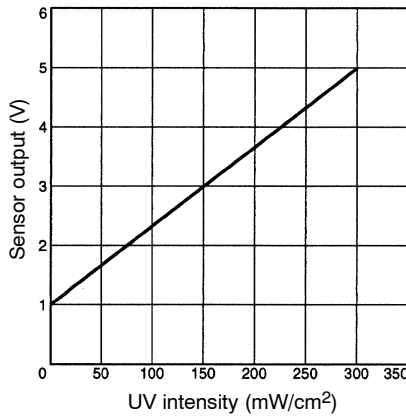

Angular Characteristics (Y-direction)

F3UV-HM

The output variation in the X-direction is less than ±10% of Full scale in a full 360° rotation.

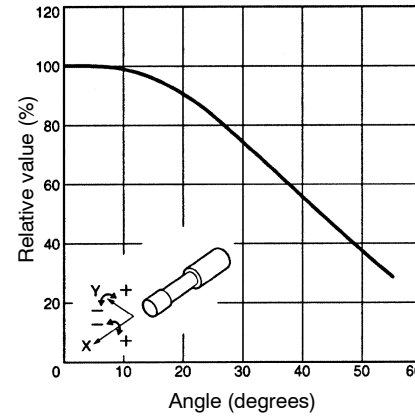

Sensitivity Characteristics

All F3UV Models

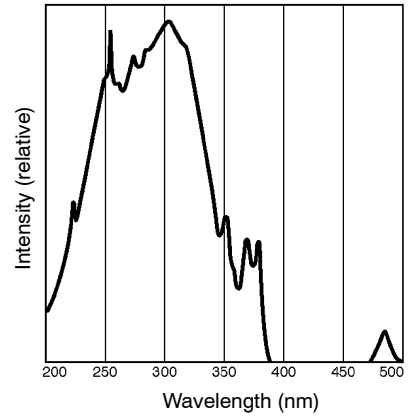

Nomenclature

■ MONITORS WITH BUILT-IN AMPLIFIERS

F3UV-A30/-A03

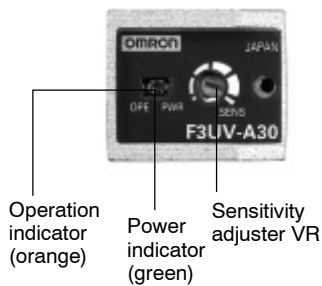

Functions

Name		Function
Display functions	Power indicator	Illuminated green when power supply is ON.
	Operation indicator	Illuminated orange when the analog output is between 4 and 5 V.
Output functions	Analog output	Outputs a voltage (1 to 5 V) proportional to the incident light. (The offset voltage is 0.2 V min.)
Sensitivity adjuster		Sensitivity can be set to the desired level with this one-turn potentiometer.

■ MONITORS WITH FIBER OPTICS

F3UV-XW11/-XW41

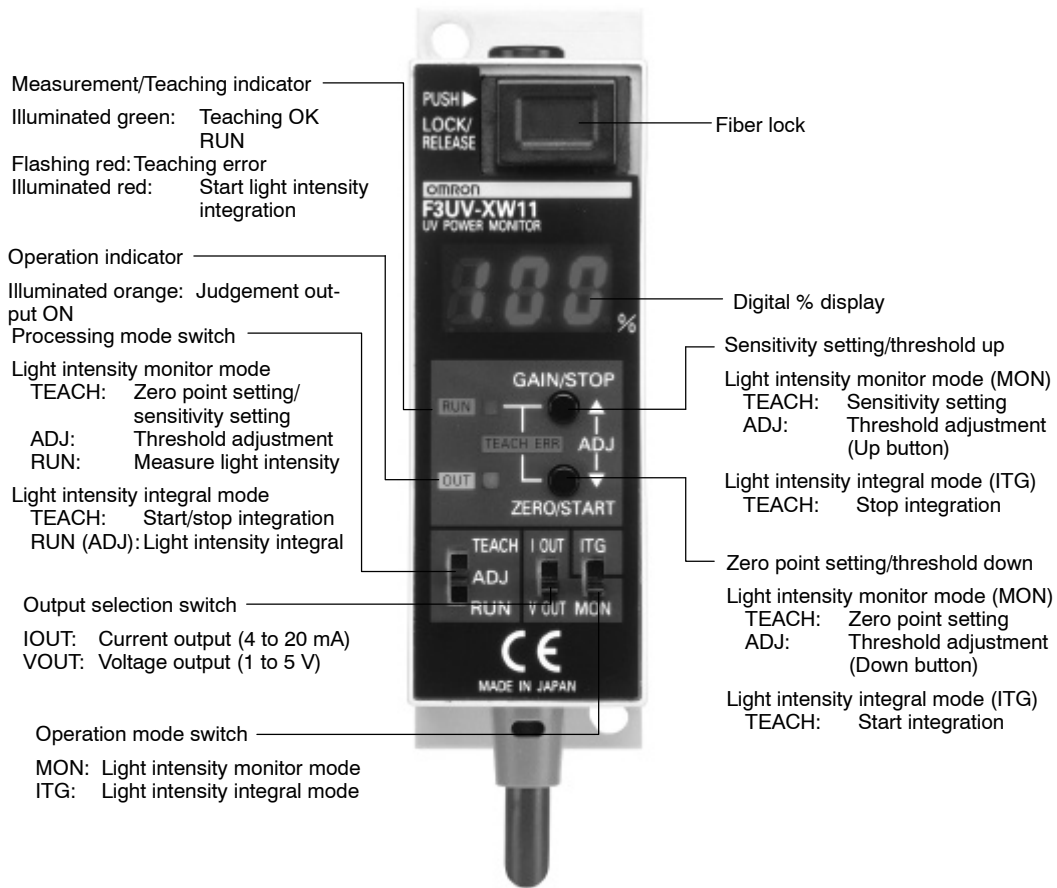

■ FUNCTIONS

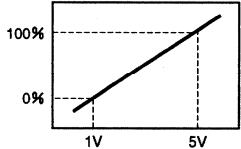
Name	Function
Indicator functions	
Measurement/teaching indicator	<ul style="list-style-type: none"> • Illuminated green: Teaching OK RUN • Flashing red: Teaching error • Illuminated red: Start light intensity integration
Operation indicator	<ul style="list-style-type: none"> • Illuminated orange: Judgement out put ON
Digital display	<ul style="list-style-type: none"> • Percentage display when operating in light intensity monitor mode HI: Greater than 124% LO: Less than 0%
Output functions	
Analog output (switchable)	<ul style="list-style-type: none"> • Outputs a current (4 to 20 mA) or voltage (1 to 5 V) that is proportional to the incident light intensity. Select current or voltage output with the output selection switch.
Judgement output	<ul style="list-style-type: none"> • ON when the incident light intensity is below the set threshold value. • OFF when the incident light intensity is above the set threshold value. (Includes a short-circuit protection function.)
Answer-back output	<ul style="list-style-type: none"> • A one pulse output (1 sec) is generated when remote teaching has been completed normally.
Input functions	
Reset input	<ul style="list-style-type: none"> • This trigger signal starts integration when the Unit is in integral mode and the processing mode is set to "RUN".
Remote teaching input	<ul style="list-style-type: none"> • When the Unit is in monitor mode or integral mode, teaching is performed when a pulse signal is input here.
Threshold setting function (monitor mode only)	<ul style="list-style-type: none"> • The desired threshold value can be set by pressing the Up and Down buttons. (The digital display will change in 1% increments when the value is set.)
Sensitivity setting function (monitor mode only)	
Zero point setting	<ul style="list-style-type: none"> • Sets the zero point reference when the UV light source is OFF. After teaching, the digital display will read "0%".
Sensitivity setting	<ul style="list-style-type: none"> • Sets the initial sensitivity when the UV light source is ON. After teaching, the digital display will read "100%".
Max. sensitivity setting	<ul style="list-style-type: none"> • Sets the sensor sensitivity to the maximum sensitivity.
Min. sensitivity setting	<ul style="list-style-type: none"> • Sets the sensor sensitivity to the minimum sensitivity.
Light intensity monitor function (Part of the current/voltage output switching function.)	<ul style="list-style-type: none"> • Displays the digital (%) value corresponding to the incident light intensity and outputs the analog and judgement outputs. 
Light intensity integral function (Part of the current/voltage output switching function.)	<ul style="list-style-type: none"> • Calculates the light intensity integral value (I) from the incident light intensity (P) and time (T) using the following equation: $I = P \times T$. Also outputs the integral's analog output simultaneously and displays the digital (%) value. (Output ON at 100%.)

Operation

I/O CIRCUIT CONFIGURATION

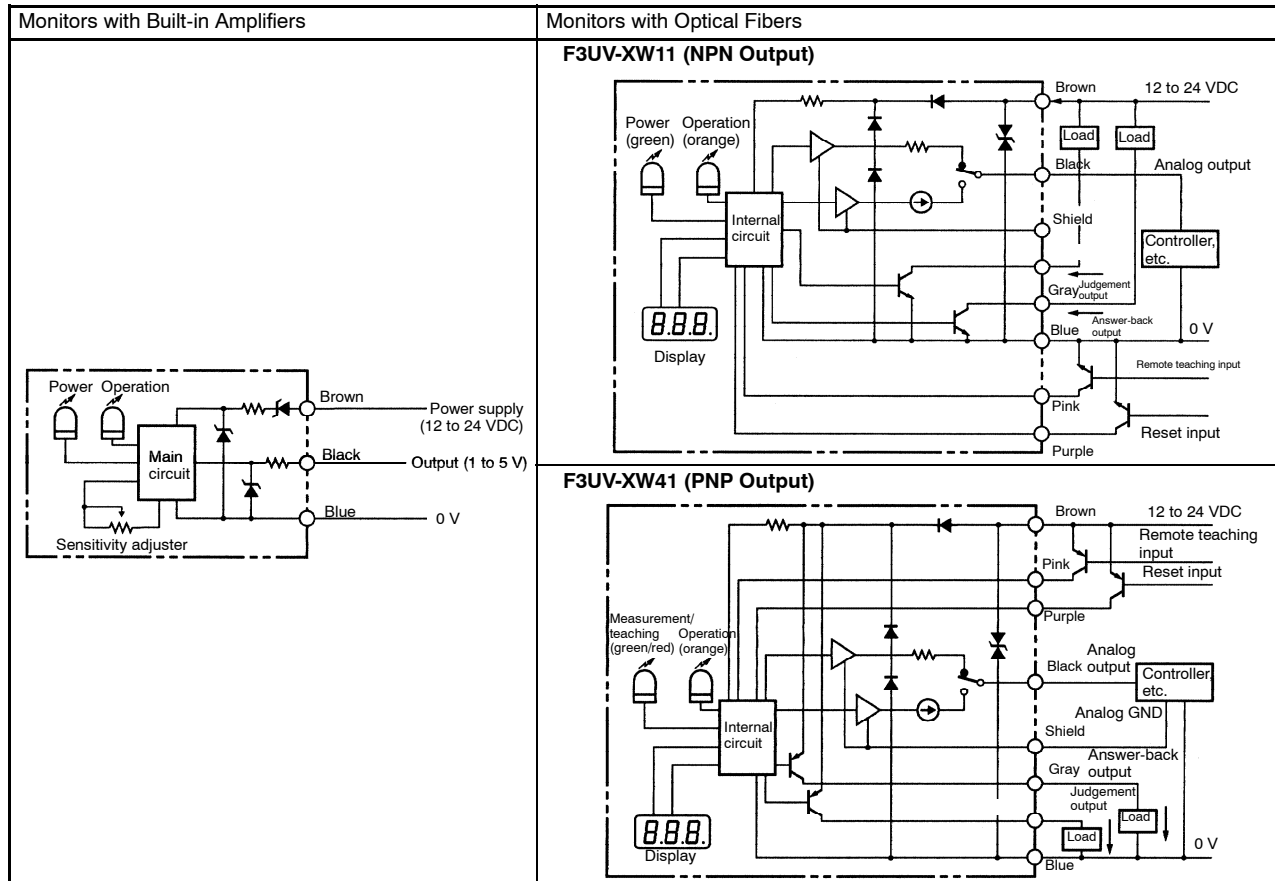

MONITORS WITH BUILT-IN AMPLIFIERS

Analog Indications such as Voltage or Current Signals

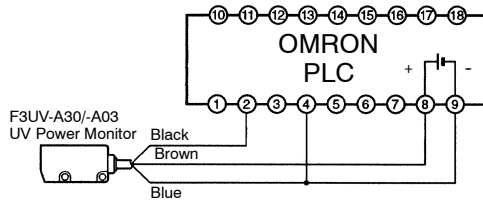

Dimensions

Unit: mm (inch)

MONITORS WITH BUILT-IN AMPLIFIERS

Main Units

F3UV-A30/-A03

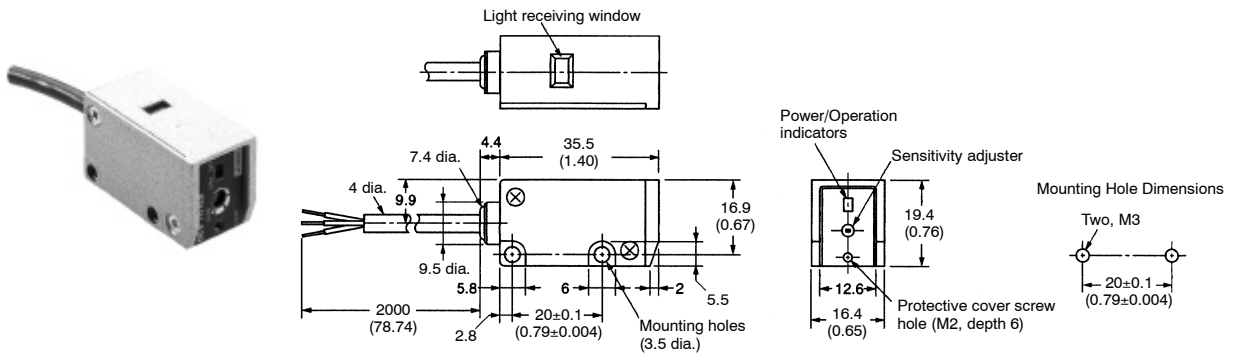

ACCESSORIES (SOLD SEPARATELY)

Protective Tube (Protects Cord.)

F39-CU1M

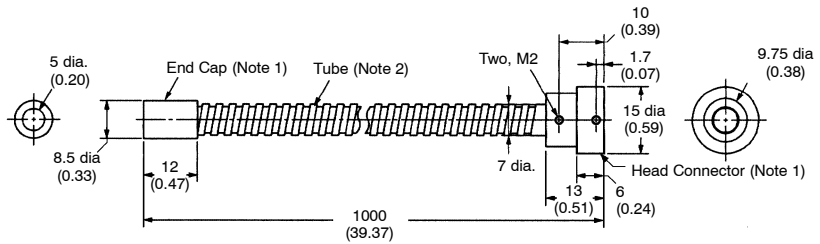
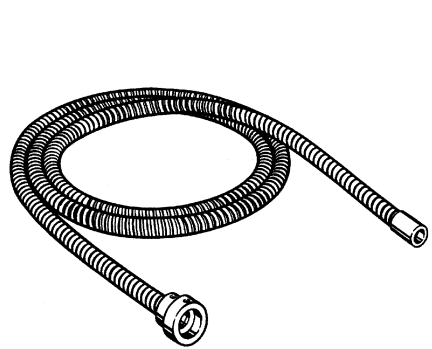

- Note:**
1. Material: C3504 (nickel-plated brass)
 2. Material: Stainless steel (SUS304)
 3. M2 securing screws are included.

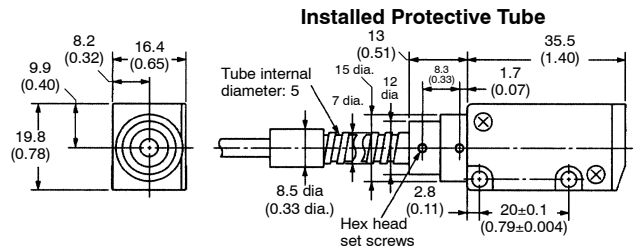

Protective Cover (Protects Display.)

F39-HU2

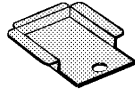

Material: Stainless steel (SUS304-CSP)

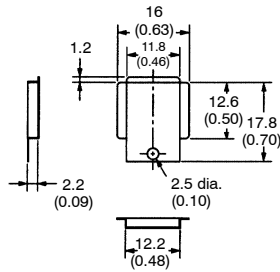

Installed Protective Cover

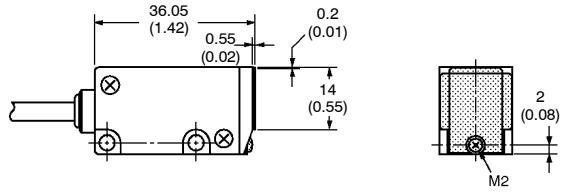

1/6.5 Filtering Cover

F39-HU1

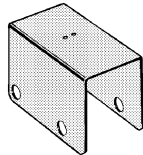

Material: Stainless steel (SUS304-CSP)

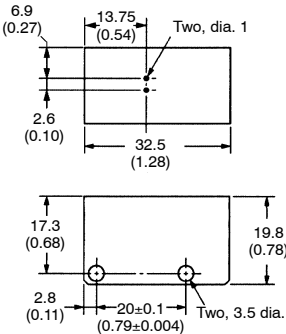

Installed 1/6.5 Filtering Cover

Two light receiving windows

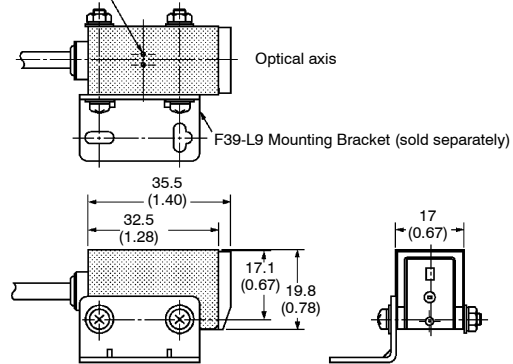

Mounting Bracket

F39-L9

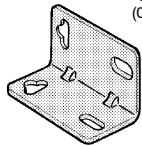

Material: Stainless steel (SUS304-CP)

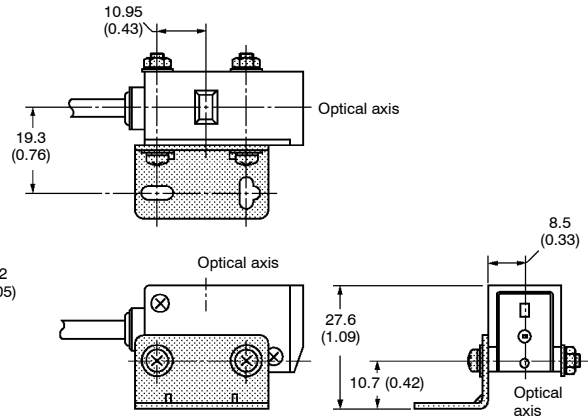
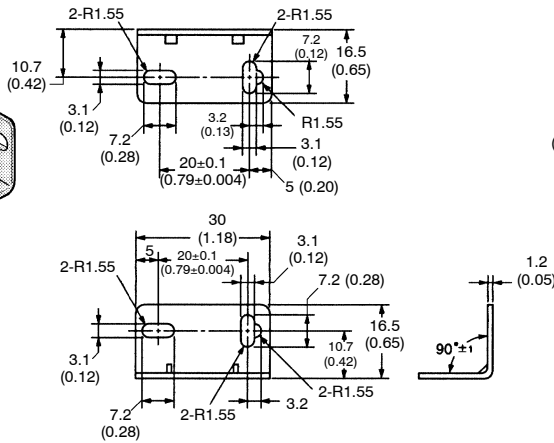

■ MONITORS WITH OPTICAL FIBERS

Main Units

Amplifier

F3UV-XW11/-XW41

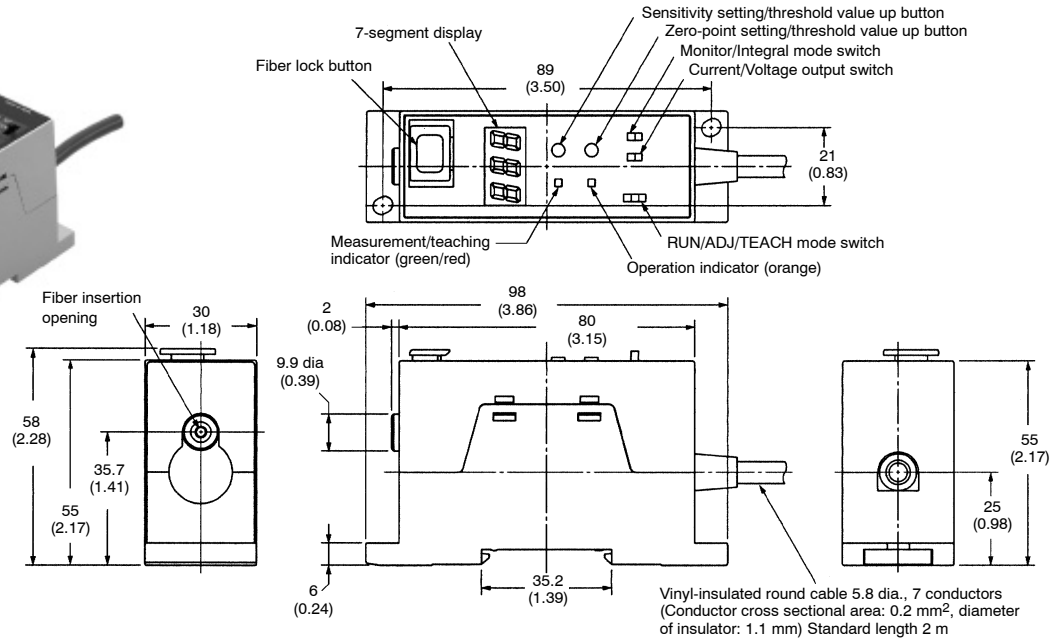
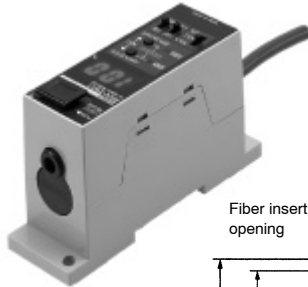

Mounting Hole Dimensions

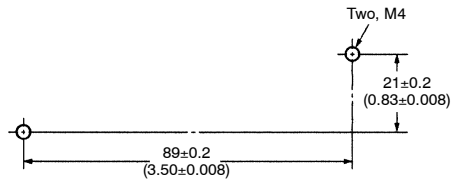

Base Unit
F3UV-HM

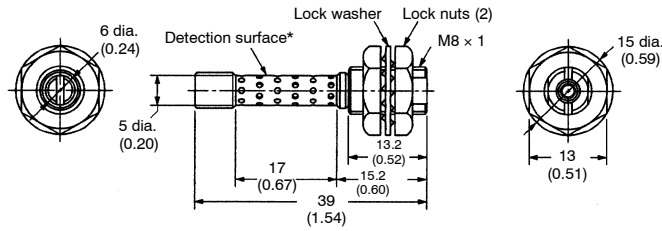

*Material: Stainless steel (SUS303)

Fiber Unit
F32-300

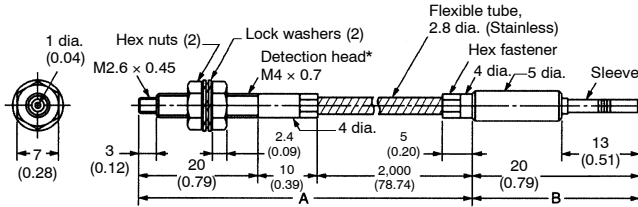

*Material: Stainless steel (SUS303)

Note: The max. temperature is 300°C in section A and 110°C in section B, which connects to the Main Unit. The part of section B that is actually inserted into the Main Unit must remain within the Main Unit's rated operating temperature range.

Fiber Unit
F32-70 (Cuttable)

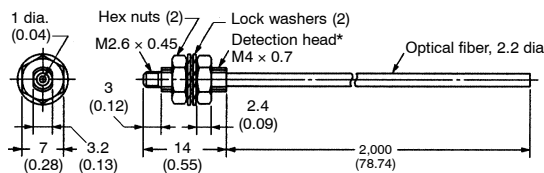

*Material: Nickel-plated brass

Note: The "cuttable" Fiber Units can be cut to length. Units that are not marked "cuttable" cannot be cut to length.

■ ACCESSORIES (SOLD SEPARATELY)

Protective Tube (Protects the Fiber.)
F32-FU1M

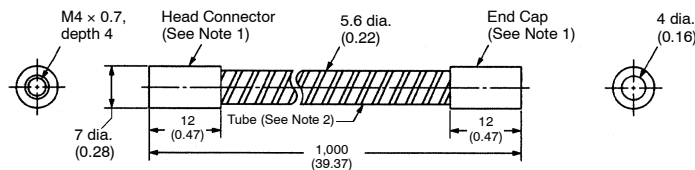
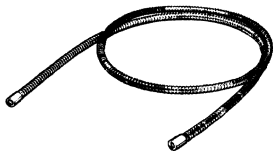

Note: 1. Material: Nickel-plated brass
2. Material: Stainless steel (SUS304)

Precautions

Be sure to observe the precautions listed here. These precautions are essential for safe operation.

- Do not use these Units in locations with flammable or explosive gases.
- Do not use these Units in water.
- Do not attempt to disassemble, repair, or improve these products.
- Always use a power supply voltage that is within the specified operating range. Do not use with an AC power supply.
- Be sure that wiring is correct, such as the polarity of the power supply leads.
- Connect loads properly.
- Do not short-circuit the load's terminals.
- Do not mount the Amplifier Unit in a location where it will be exposed to UV light.

■ PRECAUTIONS COMMON TO THE F3UV-SERIES

Wiring

Connections

Make sure that the power supply voltage is below the maximum voltage before turning the power ON.

Be sure that the terminal polarity and wiring are correct.

Never share a conduit that is used for high-voltage or power lines.

Use extension cords with a minimum thickness of 0.3 mm², less than 5 m long, and check operation before using.

Power Supply

When using a commercial switching regulator, ground the FG (frame ground) and G (ground) terminals. Output signal noise will be excessive if the power supply is not grounded.

After turning on the power supply, wait for at least one second until consistent detections can be performed before using the Monitor. If separate power supplies are used for the F3UV and connected devices, always turn ON the F3UV's power supply first.

■ INSTALLATION AND OPERATION

Installation

UV light is harmful, so be sure to turn OFF the UV light source before installing the F3UV.

Sensitivity Setting

The analog output value will change due to temperature drift. If the temperature is rising, wait for the temperature to stabilize before setting the sensitivity.

■ PRECAUTIONS FOR THE F3UV-A30/A03

Installation

Installation Torque

Torque the sensor's Main Unit screws to 0.49 N-m (0.36 ft lbs) max.

Precautions Regarding UV Light

The sensor's display and cord are not protected against UV exposure. If these parts will be exposed to UV light, protect them with the F39-HU2 Protective Cover and F39-CU1M Protective Tube.

When UV light will be in the user's field of vision or directly contact the skin during adjustment, use a shield or other protective device to prevent injury.

■ SENSITIVITY ADJUSTMENT

Use the following procedure to adjust the analog output to 5 V before initial operation or after replacing the UV light source.

1. Set up the Sensor and the UV light source to be monitored. The sensitivity adjuster is factory set to its minimum setting (all the way to the left).
2. Turn ON the UV light source.
3. Check whether the operation indicator (orange) of the Sensor is lit. The operation indicator will light if the analog output value is between 4 and 5 V. If it does not light, adjust in the following way.

Rough Adjustment

The operation indicator will light if the analog output value is between 4 and 5 V. In this case, proceed to *Fine Adjustment* below. If the operation indicator is not lit, check whether the operation indicator can be made to light by turning the sensitivity adjuster. If the operation indicator still does not light, then the UV intensity is either too high (i.e., exceeds Sensor specifications, with an analog output value greater than 5 V), or is too low. If the UV intensity is too high, make the operation indicator light by either using the F39-HU1 Filtering Cover (sold separately), or moving the Sensor farther away from the UV light source. If the UV intensity is too low, move the Sensor closer to the UV light source, until the operation indicator lights.

Fine Adjustment

Adjust the sensitivity adjuster until the analog output value is 5 V. If it not possible to obtain a value of 5 V this way, then the distance between the Sensor and the UV light source is inappropriate. Move the Sensor either closer to, or farther away from the UV light source.

■ CLEANING

Never use paint thinner or mineral spirits of any kind. If there is debris or dust on the light-receiving window, wipe it off with a soft cloth or blow it off with a low-pressure air sprayer.

■ PRECAUTIONS FOR THE F3UV-XW11/XW41

Installation

1. Installation Torque

Torque the sensor's Main Unit screws to 0.49 N·m (0.36 ft·lbs) max.

2. Using DIN Track: Installation

- A. Hook the top of the Unit onto the DIN Track.
- B. Snap the bottom of the Unit onto the DIN Track.

Note: Do not reverse steps A and B.

Removal

When removing the Unit from the DIN Track, pull the mounting hooks forward to release it.

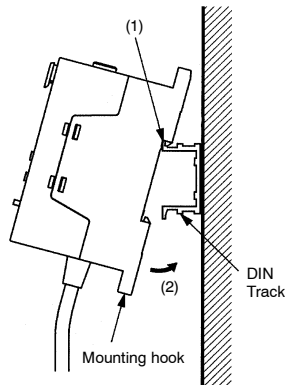

■ PRECAUTIONS REGARDING UV LIGHT

The Amplifier itself is not protected against UV exposure. Do not install the Amplifier in locations where it will be exposed to UV light.

■ OPERATION AND ADJUSTMENT

1. Install the Amplifier Unit.
2. Connect the Fiber Unit to the Amplifier Unit.
3. Turn ON the power supply.
4. Select an operating mode with the operation mode switch. (Light intensity monitor mode or light intensity integral mode)
5. When using the analog output, select current or voltage output with the output selection switch.
6. Set the processing mode switch to TEACH and perform the teaching operation.
 - Light Intensity Monitor Mode
Make the zero-point setting when the indicator is not lit and make the sensitivity setting when the indicator is lit. (Make the sensitivity setting after the temperature has stabilized.)
 - Light Intensity Integral Mode
Use the start setting at the start of illumination and the stop setting when completed. Teaching can be performed by pressing the buttons or with codes.
7. When changing the threshold value in light intensity monitor mode, set the processing mode switch to ADJ and adjust the threshold value. The judgement output will go ON when the light intensity is below the threshold value. The threshold value is set to 50 at the factory.
8. Set the processing mode switch to RUN to start measurement. In light intensity integral mode, start integration with the Reset input.

■ CLEANING

Never use paint thinner or mineral spirits of any kind.

■ FIBER UNIT/BASE UNIT

Installation

Installing the Head Unit

When connecting the Head Unit and Fiber Unit, tighten to a torque of 0.78 N·m (0.57 ft lbs) max. When installing the Head Unit, be sure to turn OFF the UV light source and check that it is safe to install the Unit.

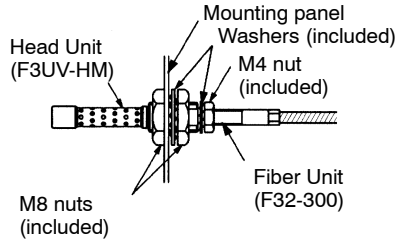

Installing the Fiber Unit and Amplifier Unit

The quality of the connection between the Fiber Unit and Amplifier Unit has a major impact on the operating characteristics, so be sure to connect these Units securely.

Securing the Fiber Unit

- Cutting the Fiber (F32-70 only)
 - Insert the fiber into the hole of the cutting tool and set the tool at the desired length.
 - Press down on the blade and cut the fiber. Do not stop when the fiber is only partially cut; make one clean cut.
 - Once a hole has been used to cut a fiber, do not use that hole again. The cut surface may not be clean enough and the detection characteristics may be degraded.
- Installing the Fiber

With the lock button in the release position, insert the fiber into the Unit and press the button until you hear a click. This click is the sound of the fiber being locked.

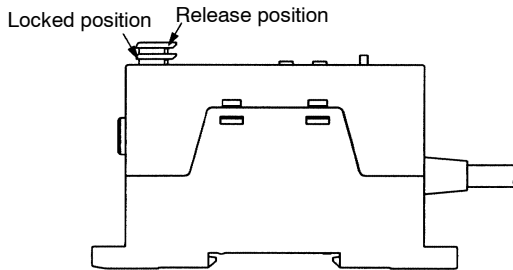

- Removing the Fiber

Press the lock button again. The lock will be released, the lock button will pop up, and it will be possible to remove the fiber. Do not force the lock button up by pulling on it. (To maintain the fiber's characteristics, check whether the lock is out of place.)

4. Fiber Insertion Location

When inserting the Fiber Unit into the Amplifier Unit, always insert the Fiber Unit completely as shown in the following diagram.

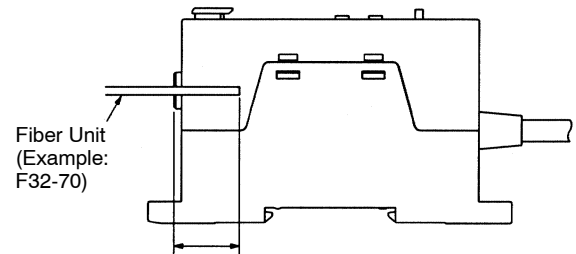
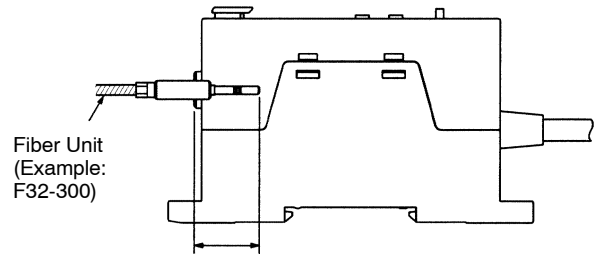

5. Fiber Unit Installation/Removal Precautions

Install and remove the Fiber Unit only when the ambient temperature is between -40° and 40° C (-40° and 104° F).

6. Protecting the Fiber Unit

When the outer sheathing of a Fiber Unit other than the F32-300 will be exposed to UV light, protect the fiber by covering it with the F39-FU1M Protective Tube.

■ APPLICATION EXAMPLES

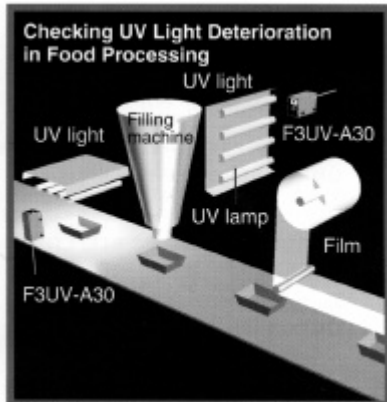
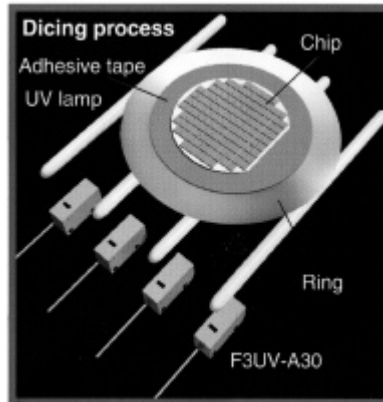
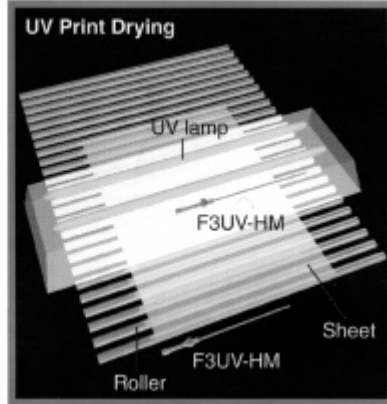
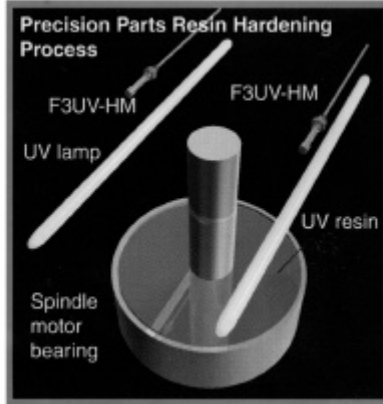

Reference Information

■ WIRE GAUGE

AWG	mm ²	Diameter (mm)	Diameter (in)
27	0.099	0.361	0.014
26	0.129	0.405	0.016
25	0.163	0.455	0.018
24	0.203	0.511	0.020
23	0.291	0.573	0.024
22	0.317	0.644	0.025
21	0.397	0.723	0.028
20	0.519	0.812	0.032
19	0.657	0.912	0.036
18	0.811	1.024	0.040
17	1.025	1.15	0.045
16	1.32	1.29	0.051
15	1.65	1.45	0.057
14	2.08	1.63	0.064
13	2.63	1.83	0.072
12	3.32	2.05	0.081

■ CONVERSIONS

Length	
1 inch = 25.4 mm	1 mm = 0.03937 inch
Torque	
1 kgf • m = 86.796 lbf • in	1 in • lb = 0.01152 kgf • m
Weight	
1 gram = 2.205 x 10 ⁻³ lbs	1 lb = 453.6 grams

Sketch

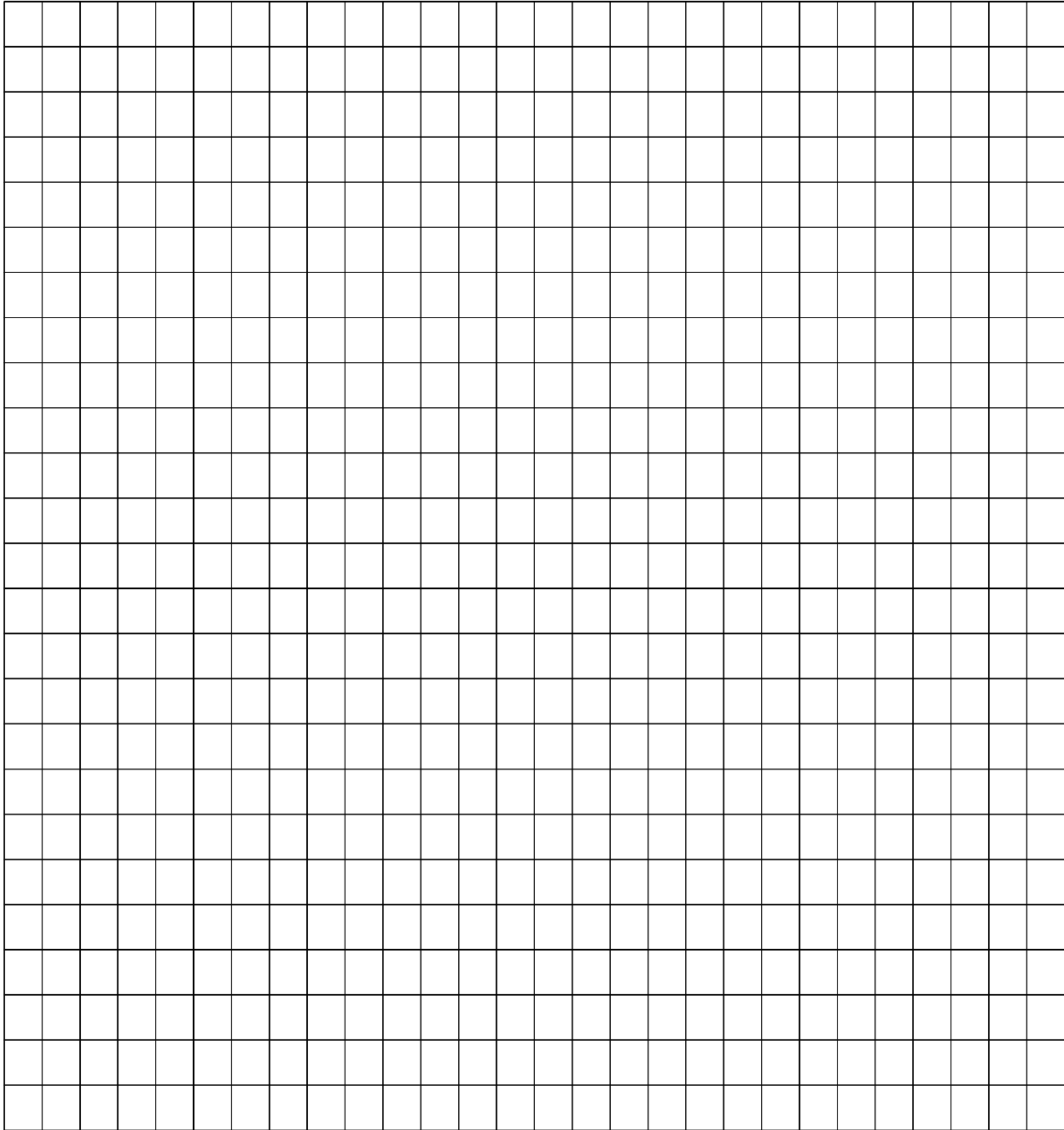

NOTE: DIMENSIONS SHOWN ARE IN MILLIMETERS. To convert millimeters to inches divide by 25.4.

OMRON[®]
OMRON ELECTRONICS, INC.
One East Commerce Drive
Schaumburg, IL 60173
1-800-55-OMRON

OMRON CANADA, INC.
885 Milner Avenue
Scarborough, Ontario M1B 5V8
416-286-6465