

Short Barrel 2-Wire AC Prox Sensors Meet IP67







- Thick nickel-plated brass barrel has wrench flats for easy installation
- Solid potted internal circuitry withstands shocks and water washdown to IP67
- High visibility indicator
- Choose prewired models with or without short-circuit protection and connector models

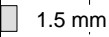
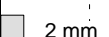

Ordering Information

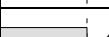

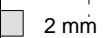
■ PREWIRED SENSORS WITHOUT SHORT-CIRCUIT PROTECTION

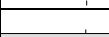
WHEN ORDERING, PLEASE NOTE: Omron has added the suffix “-N” to E2E part numbers for ordering purposes only; the suffix “-N” will not appear on the product.





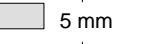
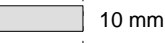

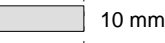
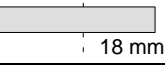

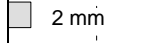
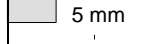

Type	Size	Sensing distance	Part number	
			NO	NC
Shielded 	M8	 1.5 mm	E2E-X1R5Y1-N	E2E-X1R5Y2-N
	M12	 2 mm	E2E-X2Y1-US-N	E2E-X2Y2-US-N
	M18	 5 mm	E2E-X5Y1-US-N*	E2E-X5Y2-US-N
	M30	 10 mm	E2E-X10Y1-US-N*	E2E-X10Y2-US-N
Unshielded 	M8	 2 mm	E2E-X2MY1-US-N*	E2E-X2MY2-US-N
	M12	 5 mm	E2E-X5MY1-US-N*	E2E-X5MY2-US-N*
	M18	 10 mm	E2E-X10MY1-US-N*	E2E-X10MY2-US-N*
	M30	 18 mm	E2E-X18MY1-US-N*	E2E-X18MY2-US-N

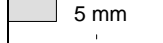
*Note: A different oscillating frequency is available to prevent mutual interference. Add a “5” to the part number (e.g., E2E-X5Y15-US-N).

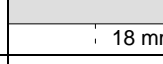
■ PREWIRED SENSORS WITH SHORT-CIRCUIT PROTECTION

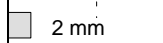
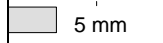
Type	Size	Sensing distance	Part number	
			NO	NC
Shielded 	M18	 5 mm	E2E-X5Y1-53-US	E2E-X5Y2-53-US
	M30	 10 mm	E2E-X10Y1-53-US	E2E-X10Y2-53-US
Unshielded 	M18	 10 mm	E2E-X10MY1-53-US	E2E-X10MY2-53-US
	M30	 18 mm	E2E-X18MY1-53-US	E2E-X18MY2-53-US

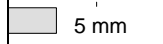
■ SENSORS WITH BUILT-IN CONNECTORS

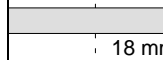
Connector	Type	Size	Sensing distance	Part number	
				NO	NC
4-pin connector (M12) See Note 1.	Shielded 	M12	 2 mm	E2E-X2Y1-M1-N	E2E-X2Y2-M1-N
		M18	 5 mm	E2E-X5Y1-M1-N	E2E-X5Y2-M1-N
		M30	 10 mm	E2E-X10Y1-M1-N	E2E-X10Y2-M1-N
	Unshielded 	M12	 5 mm	E2E-X5MY1-M1-N	E2E-X5MY2-M1-N
		M18	 10 mm	E2E-X10MY1-M1-N	E2E-X10MY2-M1-N
		M30	 18 mm	E2E-X18MY1-M1-N	E2E-X18MY2-M1-N
3-pin connector (M12) See Note 2.	Shielded 	M12	 2 mm	E2E-X2Y1-M4	E2E-X2Y2-M4
		M18	 5 mm	E2E-X5Y1-M4	E2E-X5Y2-M4
		M30	 10 mm	E2E-X10Y1-M4	E2E-X10Y2-M4
	Unshielded 	M12	 5 mm	E2E-X5MY1-M4	E2E-X5MY2-M4
		M18	 10 mm	E2E-X10MY1-M4	E2E-X10MY2-M4
		M30	 18 mm	E2E-X18MY1-M4	E2E-X18MY2-M4

Note: 1. Use Omron's Y96E-44□A□ connector cordsets.

2. Use Omron's Y96E-33□A□ connector cordsets.

■ ACCESSORIES

Description		Part number
Mounting brackets	Fits M8 size sensors Fits M12 size sensors Fits M18 size sensors Fits M30 size sensors	Y92E-B8 Y92E-B12 Y92E-B18 Y92E-B30
Silicone rubber covers for shielded sensors	Fits M12 size sensors Fits M18 size sensors Fits M30 size sensors	Y92E-E12-2 Y92E-E18-2 Y92E-E30-2
Connector cordsets	See Y96E Connector Cordsets data sheet for details	

■ REPLACEMENT PARTS

Description		Part number
Mounting hardware including one pair of metal nuts and one washer	Fits M8 size sensors Fits M12 size sensors Fits M18 size sensors Fits M30 size sensors	M8-MHWS M12-MHWS M18-MHWS M30-MHWS

Specifications

■ SENSORS WITHOUT SHORT-CIRCUIT PROTECTION (E2E-X□Y□)

Part number	E2E-X1R5Y□-N	E2E-X2MY□-N	E2E-X2Y□ -US-N	E2E-X5MY □-US-N	E2E-X5Y □-US-N	E2E-X10MY □-US-N	E2E-X10Y □-US-N	E2E-X18MY □-US-N
Size	M8		M12		M18		M30	
Type	Shielded	Unshielded	Shielded	Unshielded	Shielded	Unshielded	Shielded	Unshielded
Sensing distance	1.5 mm (0.06 in) ±10%	2 mm (0.08 in) ±10%	2 mm (0.08 in) ±10%	5 mm (0.20 in) ±10%	5 mm (0.20 in) ±10%	10 mm (0.39 in) ±10%	10 mm (0.39 in) ±10%	18 mm (0.71 in) ±10%
Supply voltage (operating voltage range) (See note 1)	24 to 240 VAC, 50/60 Hz (20 to 264 VAC)							
Current consumption	1.7 mA max.							
Sensing object	Magnetic metals (refer to <i>Engineering Data</i> for non-magnetic metals)							
Setting distance	0 to 1.2 mm (0 to 0.05 in)	0 to 1.6 mm (0 to 0.06 in)	0 to 1.6 mm (0 to 0.06 in)	0 to 4.0 mm (0 to 0.16 in)	0 to 4.0 mm (0 to 0.16 in)	0 to 8.0 mm (0 to 0.31 in)	0 to 8.0 mm (0 to 0.31 in)	0 to 14.0 mm (0 to 0.55 in)
Standard object (mild steel)	8 x 8 x 1 mm (0.31 x 0.31 x 0.04 in)	12 x 12 x 1 mm (0.47 x 0.47 x 0.04 in)	12 x 12 x 1 mm (0.47 x 0.47 x 0.04 in)	15 x 15 x 1 mm (0.59 x 0.59 x 0.04 in)	18 x 18 x 1 mm (0.71 x 0.71 x 0.04 in)	30 x 30 x 1 mm (1.18 x 1.18 x 0.04 in)	30 x 30 x 1 mm (1.18 x 1.18 x 0.04 in)	54 x 54 x 1 mm (2.13 x 2.13 x 0.04 in)
Differential travel	10% max. of sensing distance							
Response frequency	25 Hz							
Operation (with sensing object approaching)	Y1 models: Load ON Y2 models: Load OFF							
Control output (switching capacity)	5 to 100 mA max.		5 to 200 mA max.		5 to 300 mA max.			
Indicator	Operation indicator (red LED)							
Ambient temperature (See note 2)	Operating: -25°C to 70°C (-13°F to 158°F) with no icing		Operating: -40°C to 85°C (-40°F to 185°F) with no icing					
Ambient humidity	Operating: 35% to 95%							
Temperature influence	±15% max. of sensing distance at 23°C in temperature range of -40°C to 85°C (-40°F to 185°F) ±10% max. of sensing distance at 23°C in temperature range of -25°C to 70°C (-13°F to 158°F)							
Voltage influence	±1% max. of sensing distance in rated voltage range ±15%							
Residual voltage	Refer to <i>Engineering Data</i>							
Insulation resistance	50 MΩ min. (at 500 VDC) between current carry parts and case							
Dielectric strength	4,000 VAC for 1 min between current carry parts and case (2,000 VAC for M8 types)							
Vibration resistance	10 to 55 Hz, 1.5-mm double amplitude for 2 hrs each in X, Y, and Z directions							
Shock resistance	500 m/s ² (approx. 50G) for 10 times each in X, Y, and Z axes		1,000 m/s ² (approx. 50G) for 10 times each in X, Y, and Z axes 500 m/s ² (approx. 50G) for E2E-X5M					
Enclosure rating	IEC	IP67						
	NEMA	1, 4, 6, 12, 13						

- Note: 1. When using an M18 or M30 size E2E at an ambient temperature between 70°C and 85°C (158°F and 185°F), make sure that the E2E has a control output of 200 mA maximum.
2. When supplying 24 VAC to any of the above models, make sure that the operating ambient temperature range is -25°C to 85°C (-13°F to 185°F).

(This table continues on the next page.)

Specifications Table – continued from previous page

Part number		E2E-X1R5Y □-N	E2E-X2MY □-N	E2E-X2Y□- US-N	E2E-X5MY□ -US-N	E2E-X5Y□- US-N	E2E-X10MY □-US-N	E2E-X10Y □-US-N	E2E-X18MY □-US-N
Approvals	UL	–			Recognized, File Number E76675				
	CSA	–			Certified, File Number LR45951				
Weight	Prewired	Approx. 45 g		Approx. 120 g		Approx. 160 g		Approx. 270 g	
	Connector	---	Approx. 25 g			Approx. 45 g		Approx. 125 g	Approx. 124 g
Material	Body	Stainless steel		Brass					
	Sensing face	PBT							

■ SENSORS WITH SHORT-CIRCUIT PROTECTION (E2E-X□Y□-53-US)

Part number		E2E-X5Y□-53-US	E2E-X10MY□-53-US	E2E-X10Y□-53-US	E2E-X18MY□-53-US
Body	Size	M18		M30	
	Type	Shielded	Unshielded	Shielded	Unshielded
Supply voltage		90 to 140 VAC, 50/60 Hz			
Effective maximum detecting distance (with standard target)		5 mm (0.20 in) ±10%	10 mm (0.40 in) ±10%		18 mm (0.71 in) ±10%
Usable detecting range (with standard target)		0 to 4 mm (0 to 0.16 in)	0 to 8 mm (0 to 0.31 in)		0 to 14 mm (0 to 0.55 in)
Standard target size (mild steel, L x W x H)		18 x 18 x 1 mm (0.71 x 0.71 x 0.04 in)	30 x 30 x 1 mm (1.18 x 1.18 x 0.04 in)		54 x 54 x 1 mm (2.13 x 2.13 x 0.04 in)
Differential travel		10% max. of effective detecting distance			
Control output	AC solid state	Type	SCR-NO (E2E-X□□□Y1-□□-□□) SCR-NC (E2E-X□□□Y2-□□-□□)		
		Max. load	300 mA		
		Min. load	5 mA		
		Max. offstate leakage current	1.5 mA (See "Leakage Current Characteristics" graph in <i>Engineering Data</i> .)		
		Max. on-state voltage drop	(See "Leakage Current Characteristics" graph in <i>Engineering Data</i> .)		
Response frequency		25 Hz			
Circuit protection	Output short-circuit	Provided			
	Weld field immunity	Not provided			
	RFI immunity	Not provided			
Indicators		Target present (red LED)			
Materials	Housing	Nickel-plated brass			
	Sensing face	Plastic			
	Cable sheath	Plastic			
Mounting		Two lock washers and M18 nuts included. Bracket Y92E-B18 optional.		Two lock washers and M30 nuts included. Bracket Y92E-B30 optional.	
Connections	Prewired	2-conductor cable, 2 m (6.56 ft) length			
Weight with cable		Approx. 160 g (5.6 oz.)		Approx. 270 g (9.5 oz.)	
Enclosure ratings	UL	1			
	NEMA	1, 4, 6, 12, 13			
	IEC 144	IP67			
Approvals	UL	Recognized, File Number E76675			
	CSA	Certified, File Number LR45951			
Ambient operating temperature		-25° to 70°C (-13° to 158°F)			
Vibration		10 to 55 Hz, 1.5 mm (0.06 in) double amplitude			
Shock		Approx. 100 G's			

Operation

OUTPUT CIRCUITS

Sensors without Short-Circuit Protection (E2E-X□Y□)

E2E-X□Y□-N AC 2-wire Models

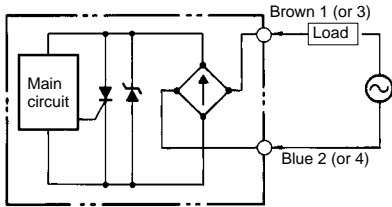

AC 2-wire Models

E2E-X□Y□-N

Sensing object	Yes	NO	NC
No		[Hatched]	[Hatched]
Red indicator	Lit	[Hatched]	[Hatched]
Not lit		[Hatched]	[Hatched]
Control output	ON	[Hatched]	[Hatched]
OFF		[Hatched]	[Hatched]

Sensors with Short-Circuit Protection (E2E-X□Y□-US-53)

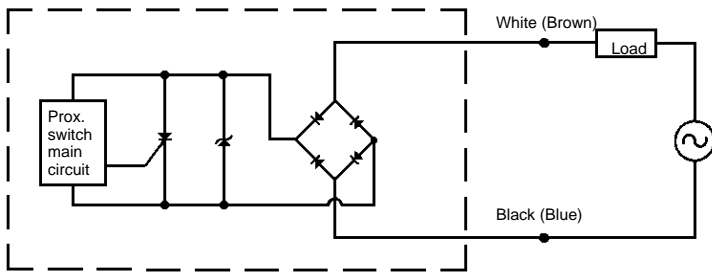

Note: IEC colors are shown in parenthesis

With Short-Circuit Protection

E2E-X□Y1-53

NO

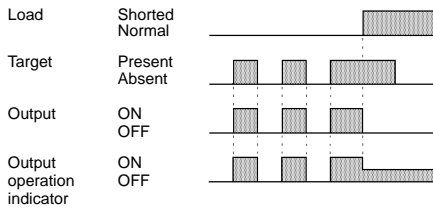

E2E-X□Y2-53

NC

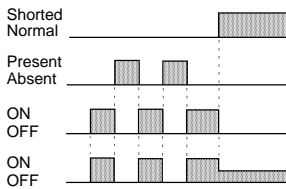

Short-Circuit Indication

The LED dims when the load is shorted and the load output immediately turns off and remains off until the short-circuit protection is reset.

Resetting Short-Circuit Protection

Before the short-circuit protection can be reset, the short must be repaired. We recommend turning the power off before repairing the short. If this approach is taken, no further action is required to reset the short-circuit protection.

If the short must be repaired with power on, the following resetting steps are required:

For NO sensors, the target must be removed to reset the short-circuit protection.

For NC sensors, the target must be presented then removed to reset the short-circuit protection.

Engineering Data

OPERATING RANGE (TYPICAL)

Shielded Models

E2E-X□Y□-N

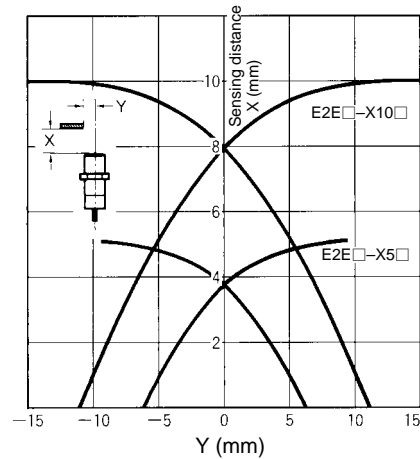
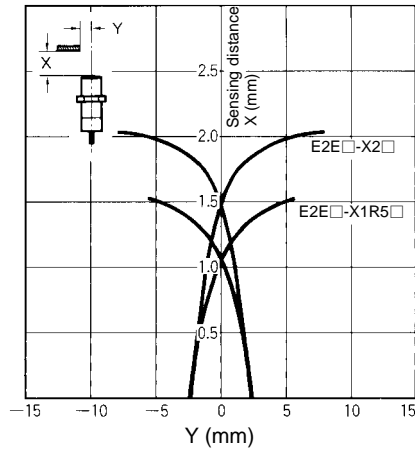

Unshielded Models

E2E-X□MY□-N

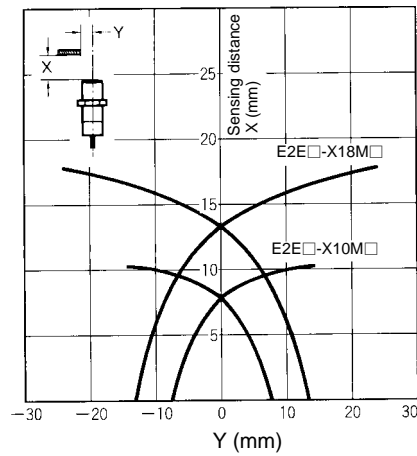
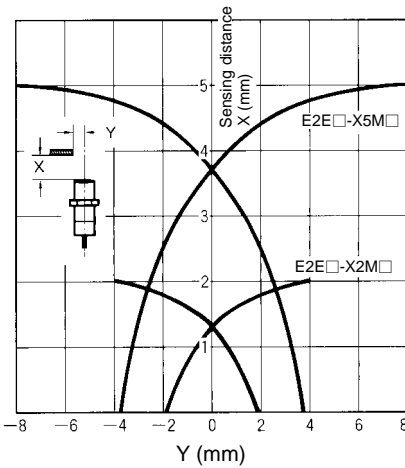

LEAKAGE CURRENT (TYPICAL)

E2E-X□Y□-N

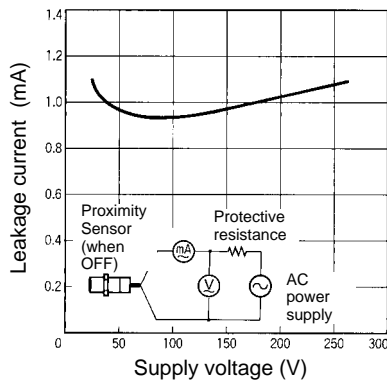

E2E-X□Y□-53-US

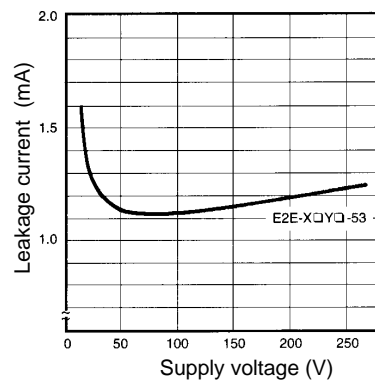

RESIDUAL OUTPUT VOLTAGE (TYPICAL)

E2E-X□Y□-N

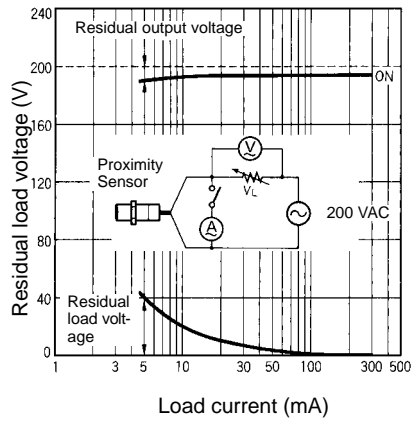
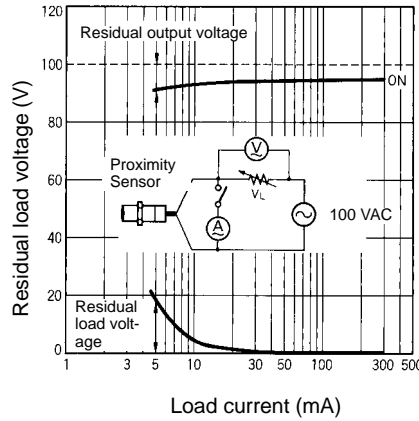
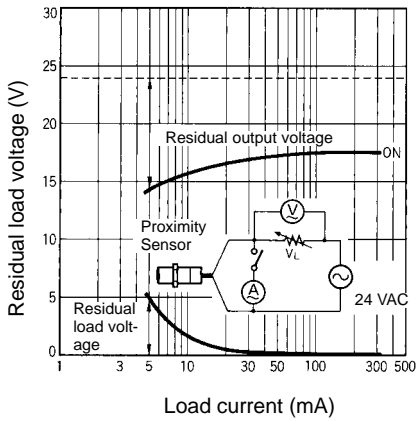

SENSING DISTANCE VS. SENSING OBJECT (TYPICAL)

E2E-X1R5Y□-N

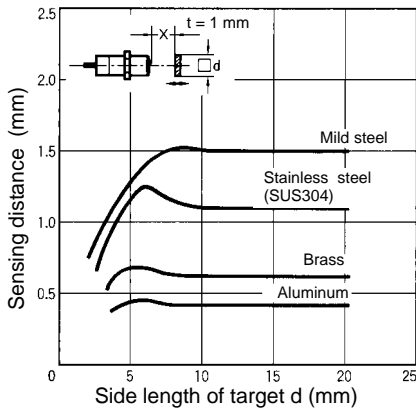

E2E-X2Y□-N

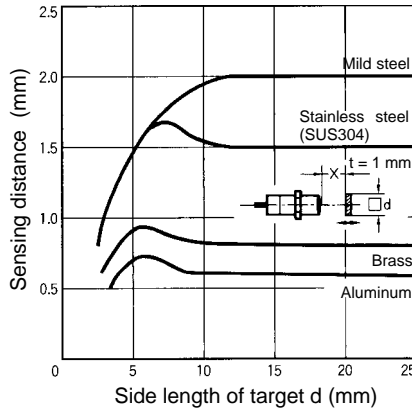

E2E-X5Y□-N

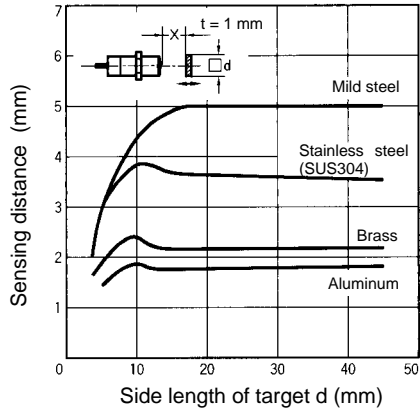

E2E-X10Y□-N

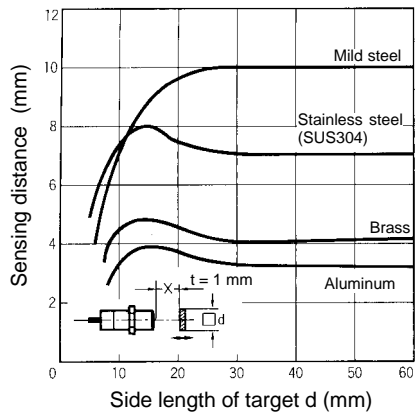

E2E-X2MY□-N

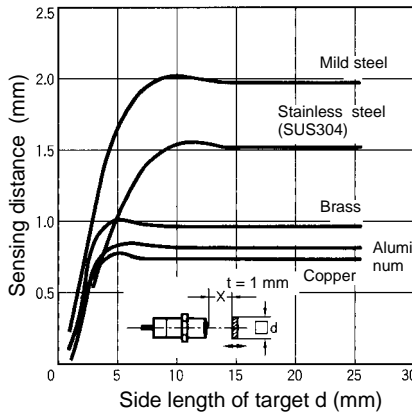

E2E-X5MY□-N

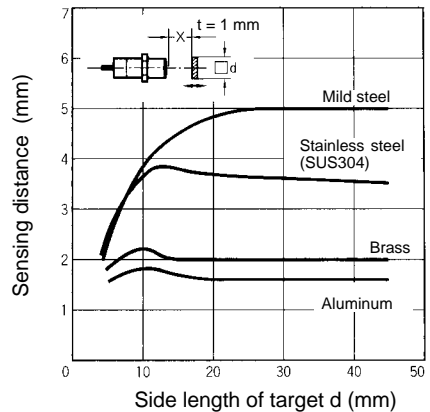

■ SENSING DISTANCE VS. SENSING OBJECT (TYPICAL) – CONTINUED

E2E-X10MY-N

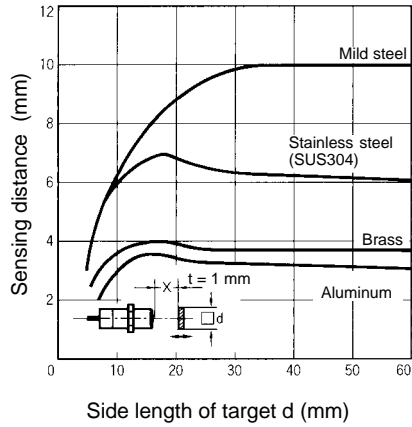

E2E-X18MY-N

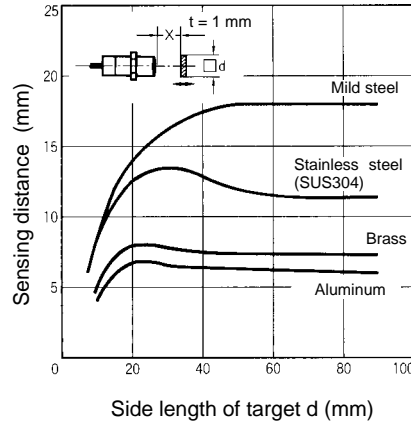

Models with Short Circuit Protection (E2E-X□Y□-53-US)

E2E-X5□□, E2E-X10□□

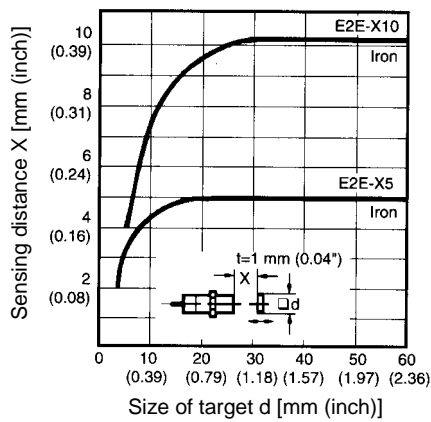

E2E-X10M□□

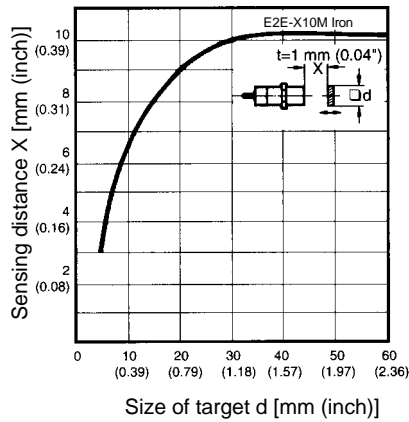

E2E-X18M□□

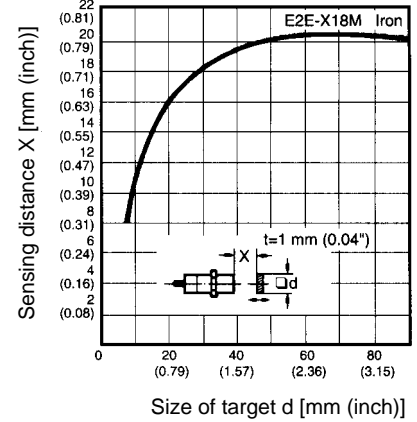

Dimensions

■ DRAWING LOCATOR

Type			Part number	Figure number
Prewired without short-circuit protection	Shielded	M8	E2E-X1R5Y□-N	1
		M12	E2E-X2Y□-N	3
		M18	E2E-X5Y□-N	5
		M30	E2E-X10Y□-N	7
	Unshielded	M8	E2E-X2MY□-N	2
		M12	E2E-X5MY□-N	4
		M18	E2E-X10MY□-N	6
		M30	E2E-X18MY□-N	8
Prewired with short-circuit protection	Shielded	M18	E2E-X5Y□-53-US	9
		M30	E2E-X10Y□-53-US	11
	Unshielded	M18	E2E-X10MY□-53-US	10
		M30	E2E-X18MY□-53-US	12
4-pin connector (M12)	Shielded	M12	E2E-X2Y-□-M1-N	13
		M18	E2E-X5Y1-M1-N	15
		M30	E2E-X10Y-□-M1-N	17
	Unshielded	M12	E2E-X5MY-□-M1-N	14
		M18	E2E-X10MY-□-M1-N	16
		M30	E2E-X18MY-□-M1-N	18
3-pin MicroChange connector (M12)	Shielded	M12	E2E-X2Y-□-M4	13
		M18	E2E-X5Y-□-M4	15
		M30	E2E-X10Y-□-M4	17
	Unshielded	M12	E2E-X5MY-□-M4	14
		M18	E2E-X10MY-□-M4	16
		M30	E2E-X18MY-□-M4	18

Unit: mm (inch)

Prewired Models (Shielded)

Fig. 1: E2E-X1R5Y□-N

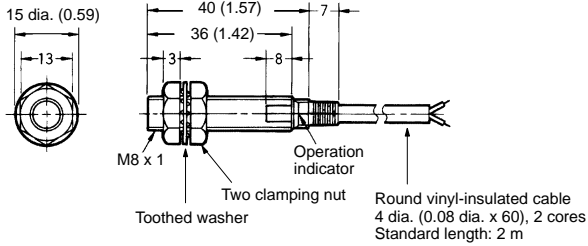

Prewired Models (Unshielded)

Fig. 2: E2E-X2MY□-N

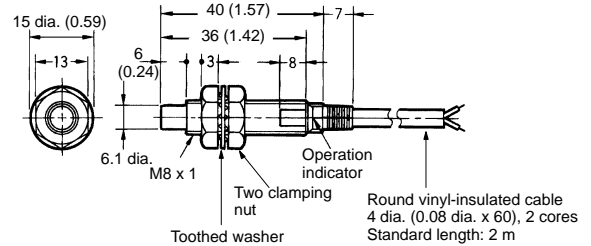

Fig. 3: E2E-X2Y□-N

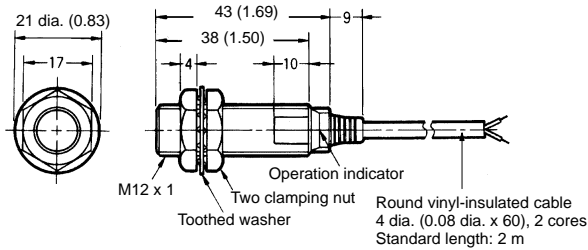

Fig. 4: E2E-X5MY□-N

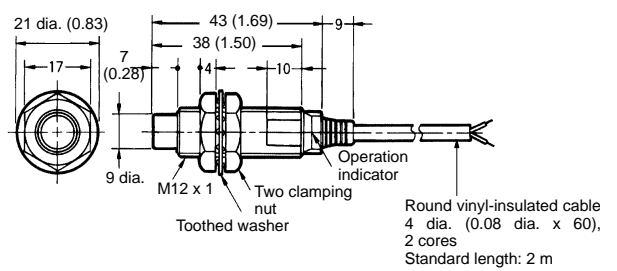

Fig. 5: E2E-X5Y□-N

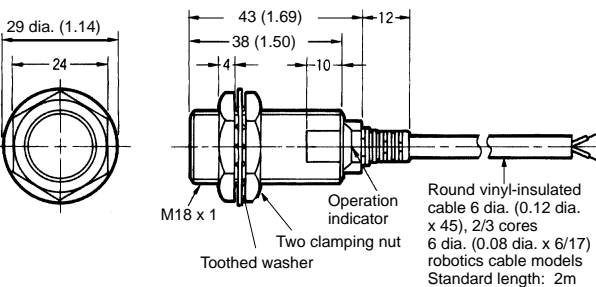

Fig. 6: E2E-X10MY□-N

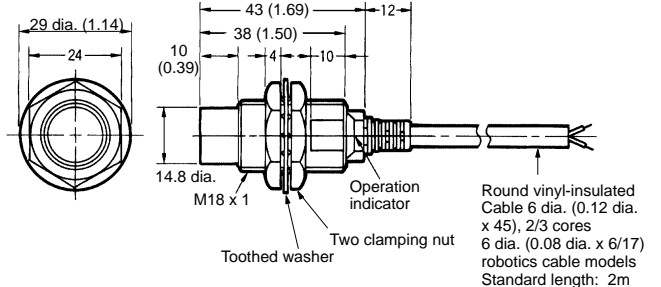

Fig. 7: E2E-X10Y□-N

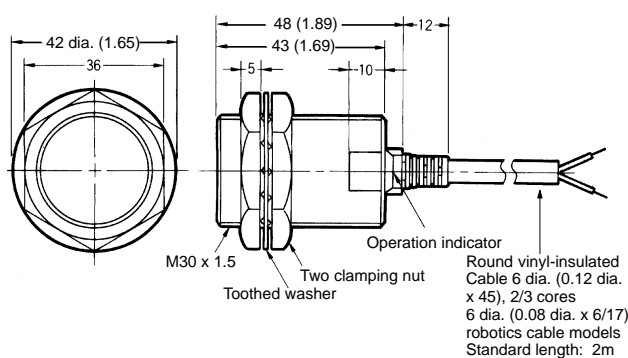
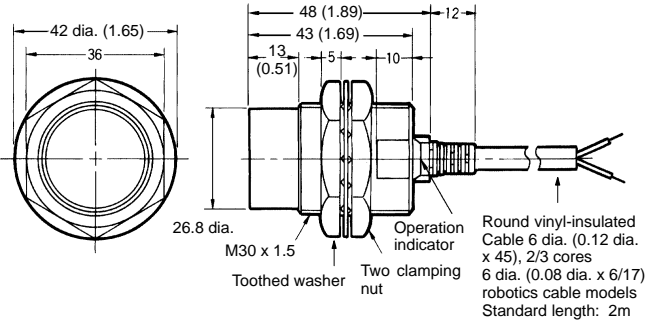

Fig. 8: E2E-X18MY□-N



PRE-WIRED MODELS WITH SHORT-CIRCUIT PROTECTION

Shielded

Fig. 9:

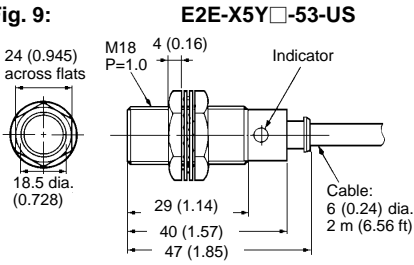

Unshielded

Fig.10:

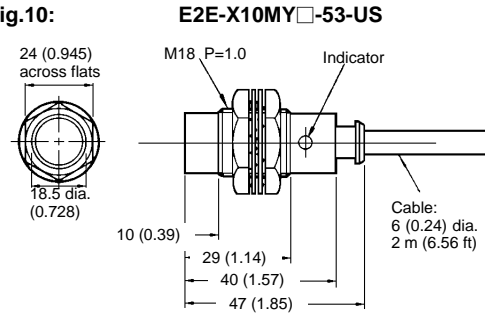

Fig. 11:

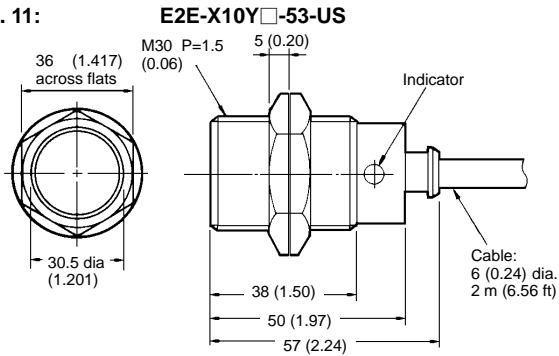
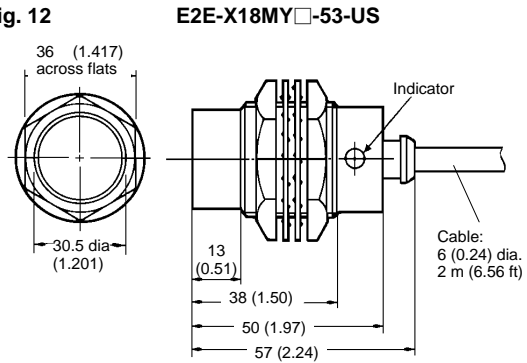
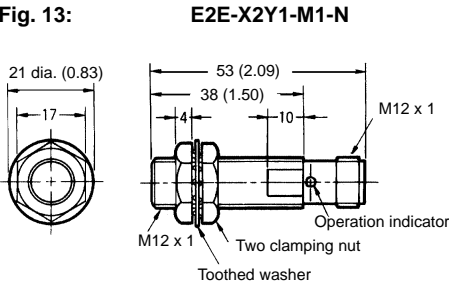

Fig. 12



Connector Models (Shielded)

Fig. 13:



Connector Models (Unshielded)

Fig. 14:

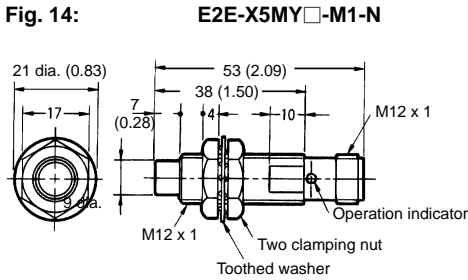

Fig. 15:

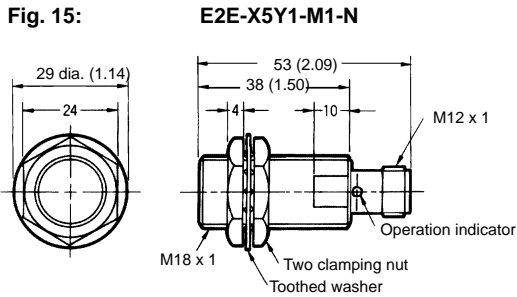
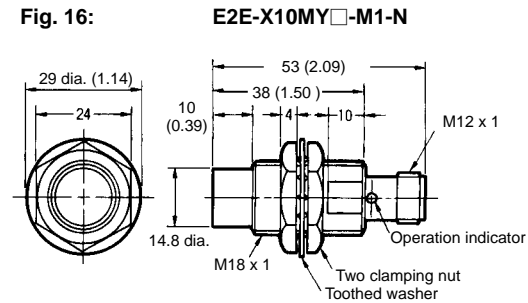
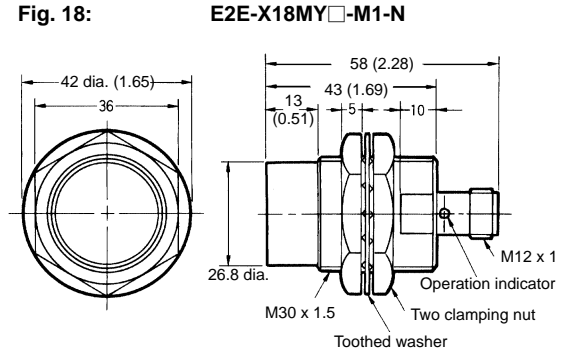
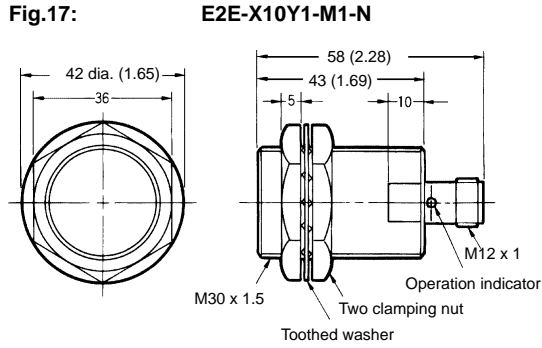

Fig. 16:



Connector Models (Shielded), continued

Connector Models (Unshielded), continued



■ MOUNTING HOLES

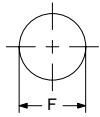

Dimensions	M8	M12	M18	M30
F (mm)	8.5 ^{+0.5} / ₀ dia.	12.5 ^{+0.5} / ₀ dia.	18.5 ^{+0.5} / ₀ dia.	30.5 ^{+0.5} / ₀ dia.

Installation

■ PIN ARRANGEMENT

E2E-X□Y□-M1 AC 2-wire Models

Output configuration	Applicable models	Pin arrangement
NO	E2E-X□Y1-M1-N	<p>Note: Terminals 1 and 2 are not used.</p>
NC	E2E-X□Y2-M1-N	<p>Note: Terminals 3 and 4 are not used.</p>
NO, NC	E2E-X□Y□-M4	

Precautions

■ MOUNTING

Do not tighten the nut with excessive force. A washer must be used with the nut.

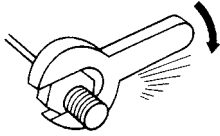

Shielded Model

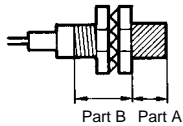

Unshielded Model

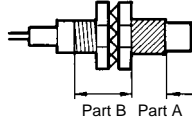

Type	Part A		Part B
	Length	Torque	Torque
M8	Shielded	9 mm	12 N • m (90 kgf • cm)
	Unshielded	3 mm	
M12	30 N • m (310 kgf • cm)		
M18	70 N • m (710 kgf • cm)		
M30	180 N • m (1,800 kgf • cm)		

Note: The table above right shows the tightening torques for part A and part B nuts. In the previous examples, the nut is on the sensor head side (part B) and hence the tightening torque for part B applies. If this nut is in part A, the tightening torque for part A applies instead.

■ EFFECTS OF SURROUNDING METAL

When mounting the E2E within a metal panel, ensure that the clearances given in the following table are maintained. Failure to maintain these distances may cause deterioration in the performance of the sensor.

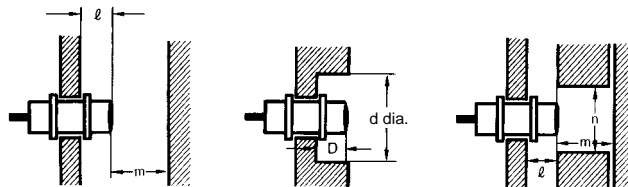

Type		Dimension	M8	M12	M18	M30
E2E-X□Y□-N AC 2-wire	Shielded	ℓ	0 mm	0 mm	0 mm	0 mm
		d	8 mm	12 mm	18 mm	30 mm
		D	0 mm	0 mm	0 mm	0 mm
		m	4.5 mm	8 mm	20 mm	40 mm
		n	12 mm	18 mm	27 mm	45 mm
	Unshielded	ℓ	6 mm	15 mm	22 mm	30 mm
		d	24 mm	40 mm	55 mm	90 mm
		D	6 mm	15 mm	22 mm	30 mm
		m	8 mm	20 mm	40 mm	70 mm
		n	24 mm	36 mm	54 mm	90 mm

■ MUTUAL INTERFERENCE

When installing two or more Sensors face-to-face or side-by-side, ensure that the minimum distances given in the following table are maintained.

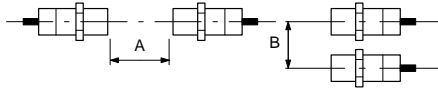

Type		Dimension	M8	M12	M18	M30
E2E-X□Y□-N AC 2-wire	Shielded	A	20 mm	30 (20) mm	50 (30) mm	100 (50) mm
		B	15 mm	20 (12) mm	35 (18) mm	70 (35) mm
	Unshielded	A	80 mm	120 (60) mm	200 (100) mm	300 (100) mm
		B	60 mm	100 (50) mm	110 (60) mm	200 (100) mm

Note: The figures in parentheses refer to Sensors operating at different frequencies.

■ INSTALLATION

Power Reset Time

The Proximity Sensor is ready to operate within 100 ms after power is supplied. If power supplies are connected to the Proximity Sensor and load respectively, be sure to supply power to the Proximity Sensor before supplying power to the load.

Power OFF

The Proximity Sensor may output a pulse signal when it is turned off. Therefore, it is recommended to turn off the load before turning off the Proximity Sensor.

Power Supply Transformer

When using a DC power supply, make sure that the DC power supply has an insulated transformer. Do not use a DC power supply with an auto-transformer.

Sensing Target

Metal Coating:

The sensing distances of the Proximity Sensor vary with the metal coating on sensing targets.

■ WIRING

High-tension Lines

Wiring through Metal Conduit

If there is a power or high-tension line near the cord of the Proximity Sensor, wire the cord through an independent metal conduit to prevent against Proximity Sensor damage or malfunctioning.

Cable Tractive Force

Do not pull cable with the tractive forces exceeding the following.

Diameter	Tractive force
4 mm dia. max.	30 N max.
4 mm dia. min.	50 N max.

■ MOUNTING

The Proximity Sensor must not be subjected to excessive shock with a hammer when it is installed, or the Proximity Sensor may be damaged or lose its water-resistance.

■ ENVIRONMENT

Water Resistance

Do not use the Proximity Sensor underwater, outdoors, or in the rain.

Operating Environment

Be sure to use the Proximity Sensor within its operating ambient temperature range and do not use the Proximity Sensor outdoors to maintain its reliability and life expectancy. Although the Proximity Sensor is water resistant, a cover to protect the Proximity Sensor from water or water soluble machining oil is recommended so that its reliability and life expectancy can be maintained.

Do not use the Proximity Sensor in an environment with chemical gas (e.g., strong alkaline or acid gasses including nitric, chromic, and concentrated sulfuric acid gases).

CONNECTING LOAD TO AC 2-WIRE SENSOR

Refer to the following before using AC or DC 2-wire Proximity Sensors.

Surge Protection

Although the Proximity Sensor has a surge absorption circuit, if there is any machine that has a large surge current (e.g., a motor or welding machine) near the Proximity Sensor, connect a surge absorber to the machine.

Leakage Current

When it is OFF, the Proximity Sensor has leakage current. Refer to Leakage Current Characteristics. In this case, the load is imposed with a small voltage and the load may not be reset. Before using the Proximity Sensor, make sure that this voltage is less than the load reset voltage. The AC 2-wire Proximity Sensor cannot be connected to any card-lift-off relay (e.g., the G2A) because contact vibration of the relay will be caused by the leakage current and the life of the relay will be shortened.

Countermeasures Against Leakage Current

AC 2-wire Models

Connect a bleeder resistor as the bypass for the leakage current so that the current flowing into the load will be less than the load reset current.

As shown in the following diagram, connect the bleeder resistor so that the current flowing into the Proximity Sensor will be 10 mA minimum and the residual voltage imposed on the load will be less than the load reset voltage.

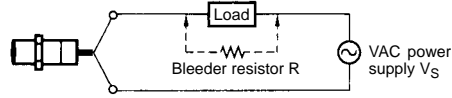

Refer to the following to calculate the bleeder resistance and the allowable power of the bleeder resistor.

$$R \leq V_S / (10 - I) \text{ (k}\Omega\text{)}$$

$$P > V_S^2 / R \text{ (mW)}$$

P: The allowable power of the bleeder resistor. (The actual power capacity of the bleeder resistor must be at least a few times as large as the allowable power of the bleeder resistor.)

I: Load current (mA)

The following resistors are recommended.

100 VAC (supply voltage): A resistor with a resistance of 10 kΩ maximum and an allowable power of 3 W minimum

200 VAC (supply voltage): A resistor with a resistance of 20 kΩ maximum and an allowable power of 10 W minimum

If these resistors generate excessive heat, use a resistor with a resistance of 10 kΩ maximum and an allowable power of 5 W minimum at 100 VAC and a resistor with a resistance of 20 kΩ maximum and an allowable power of 10 W minimum at 200 VAC instead.

PRECAUTIONS FOR AC 2-WIRE PROXIMITY SENSORS IN OPERATION

Connector

Model	Connection type	Method	Description
AC 2-wire	AND (serial connection)		<p>If 100 or 200 VAC is imposed on the Proximity Sensors, V_L (i.e., the voltage imposed on the load) will be obtained from the following.</p> $V_L = V_S - (\text{residual voltage} \times \text{no. of Proximity Sensors}) \text{ (V)}$ <p>Therefore, if V_L is lower than the load operating voltage, the load will not operate.</p> <p>A maximum of three Proximity Sensors can be connected in series provided that the supply voltage is 100 V minimum.</p>

■ PRECAUTIONS FOR AC 2-WIRE PROXIMITY SENSORS IN OPERATION, CONTINUED

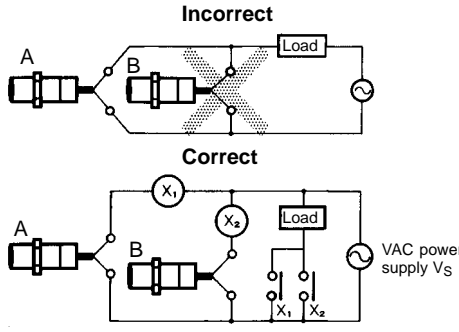
Model	Connection type	Method	Description
AC 2-wire	OR (parallel connection)		<p>In principle, more than two Proximity Sensors cannot be connected in parallel.</p> <p>Provided that Proximity Sensor A does not operate with Proximity Sensor B simultaneously and there is no need to keep the load operating continuously, the Proximity Sensors can be connected in parallel. In this case, however, due to the total leakage current of the Proximity Sensors, the load may not reset properly.</p> <p>It is not possible to keep the load operating continuously with Proximity Sensors A and B in simultaneous operation to sense sensing objects due to the following reason.</p> <p>When Proximity Sensor A is ON, the voltage imposed on Proximity Sensor A will drop to approximately 10 V and the load current flows into Proximity Sensor A, and when one of the sensing objects is close to Proximity Sensor B, Proximity Sensor B will not operate because the voltage imposed on Proximity Sensor B is 10 V, which is too low. When Proximity Sensor A is OFF, the voltage imposed on Proximity Sensor B will reach the supply voltage and Proximity Sensor B will be ON. Then, Proximity Sensor A as well as Proximity Sensor B will be OFF for approximately 10 ms, which resets the load for an instant. To prevent the instantaneous resetting of the load, use a relay as shown on the left.</p>

NOTE: DIMENSIONS SHOWN ARE IN MILLIMETERS. To convert millimeters to inches divide by 25.4.

OMRON[®]
OMRON ELECTRONICS, INC.
 One East Commerce Drive
 Schaumburg, IL 60173
1-800-55-OMRON

OMRON CANADA, INC.
 885 Milner Avenue
 Scarborough, Ontario M1B 5V8
416-286-6465