

Surface Mount Aluminum Electrolytic Capacitors NATK Series

FEATURES

- EXTENDED TEMPERATURE +125°C & LONG LIFE (T0 5,000 HOURS)
- AVAILABLE WITH ANTI-VIBRATION WIDE TERMINATIONS
- CYLINDRICAL V-CHIP CONSTRUCTION FOR SURFACE MOUNTING
- DESIGNED FOR AUTOMATIC MOUNTING AND REFLOW SOLDERING
- MEETS THE REQUIREMENTS OF AEC-Q200*

*Contact NIC for supporting test data

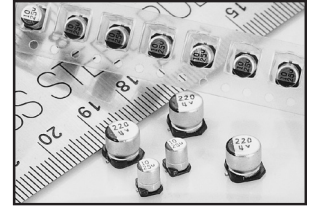

CHARACTERISTICS

Rated Voltage Range	16 ~ 50VDC				
Rated Capacitance Range	10 ~ 3900 μ F				
Operating Temp. Range	-40 ~ +125°C				
Capacitance Tolerance	\pm 20% (M)				
Max. Leakage Current After 2 Minutes @ 20°C	0.01CV or 3 μ A whichever is greater				
Working & Surge Voltage Ratings	W.V. (Vdc)	16	25	35	50
	S.V. (Vdc)	20	32	44	63
Tan δ @ 120Hz/20°C		See specifications table (page 2)			
Low Temperature Stability Impedance Ratio @ 120Hz	W.V. (Vdc)	16	25	35	50
	Z -25°C/Z +20°C	2	2	2	2
	Z -40°C/Z +20°C	4	3	3	3
Load Life Test at W.V. @ 125°C 6.3 ~ 10mm Diameter: 2,000 Hours 12.5mm Diameter: 3,000 Hours 16 ~ 18mm Diameter: 5,000 Hours	Capacitance Change	Within \pm 30% of initial measured value			
	Tan δ	Less than 300% of specified max. value			
	Leakage Current	Less than specified max. value			

STANDARD PRODUCT AND CASE SIZE D ϕ xL (mm)

Cap. (μ F)	Code	Working Voltage (Vdc)			
		16	25	35	50
10	100	-	-	-	6.3X6.3
22	220	-	-	6.3X6.3	-
33	330	-	6.3X6.3	6.3X6.3	-
		-	-	6.3X8	-
47	470	6.3X6.3	-	6.3X8	8X10.8
100	101	6.3X8	6.3X8	8X10.8	10X10.8
160	161	-	-	8X10.8	-
220	221	-	8X10.8	10X10.8	12.5X14
270	271	-	8X10.8	-	-
300	301	-	-	10X10.8	-
330	331	8X10.8	10X10.8	12.5X14	-
390	391	8X10.8	-	-	-
470	471	10X10.8	10X10.8	12.5X14	16X17
620	621	-	-	12.5X14	-
680	681	10X10.8	12.5X14	16X17	18X17.5
910	911	-	12.5X14	-	-
1000	102	12.5X14	16X17	16X17	18X22
1500	152	12.5X14	16X17	18X17.5	-
2200	222	16X17	18X17.5	18X22	-
3300	332	18X17.5	18X22	-	-
3900	392	18X22	-	-	-

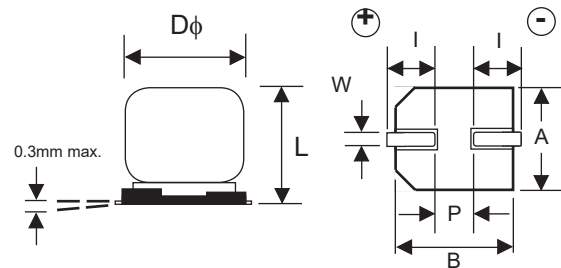

DIMENSIONS (mm)

Case Size	D ϕ \pm 0.5	L max.*	A, B \pm 0.2	I \pm 0.3	P \pm 0.3	W
6.3x6.3	6.3	6.3	6.6	2.5	2.2	0.5 ~ 0.8
6.3x8	6.3	8.0	6.6	2.5	2.2	0.5 ~ 0.8
8x10.8	8.0	10.8	8.3	2.9	3.2	0.7 ~ 1.1
10x10.8	10.0	10.8	10.3	3.2	4.6	0.7 ~ 1.4
12.5x14	12.5	14.0	12.8	4.5	4.6	1.0 ~ 1.4
16x17	16.0	17.0	16.3	5.2	7.0	1.7 ~ 2.1
18x17.5	18.0	17.5	19.0	6.5	7.0	1.7 ~ 2.1
18x22	18.0	*21.5 ^{+0.5} / _{-1.0}	19.0	6.5	7.0	1.7 ~ 2.1

Reflow Code
J = +240°C
K = +245°C
L = +250°C
N = +260°C

Termination / Packaging Code
LB = Sn-Bi / 15" reel
LS = Sn / 15" reel

Note: 16mm & 18mm diameter parts are only available with Sn finish

PRECAUTIONS

Please review the notes on correct use, safety and precautions found at <https://www.niccomp.com/resource/files/aluminum/AlumApplInfoCautions.pdf>
If in doubt or uncertainty, please review your specific application - process details with NIC's technical support personnel: tpmg@niccomp.com



Surface Mount Aluminum Electrolytic Capacitors NATK Series

STANDARD VALUES, CASE SIZES & SPECIFICATIONS

Part Number	Cap. (μF)	Working Voltage	Dissipation Factor @120Hz/+20°C	Max. ESR (Ω) AT 100KHz/+20°C	Max. Ripple Current (mA rms) AT 100KHz/+125°C	Load Life Hours @ +125°C	
NATK470M16V6.3X6.3NLBYF	47	16	0.20	1.60	110	2,000	
NATK101M16V6.3X8NLBYF	100		0.20	0.45	200	2,000	
NATK331M16V8X10.8NLBYF	330		0.20	0.18	300	2,000	
NATK391M16V8X10.8NLBYF	390		0.20	0.18	300	2,000	
NATK471M16V10X10.8LLBYF	470		0.20	0.11	500	2,000	
NATK681M16V10X10.8LLBYF	680		0.20	0.11	500	2,000	
NATK102M16V12.5X14KLBYF	1000		0.20	0.08	1200	3,000	
NATK152M16V12.5X14KLBYF	1500		0.20	0.08	1200	3,000	
NATK222M16V16X17JLSYF	2200		0.22	0.05	1800	5,000	
NATK332M16V18X17.5JLSYF	3300		0.24	0.045	2000	5,000	
NATK392M16V18X22JLSYF	3900		0.24	0.040	2200	5,000	
NATK330M25V6.3X6.3NLBYF	33	25	0.16	1.60	110	2,000	
NATK101M25V6.3X8NLBYF	100		0.16	0.45	200	2,000	
NATK221M25V8X10.8NLBYF	220		0.16	0.18	300	2,000	
NATK271M25V8X10.8NLBYF	270		0.16	0.18	300	2,000	
NATK331M25V10X10.8LLBYF	330		0.16	0.11	500	2,000	
NATK471M25V10X10.8LLBYF	470		0.16	0.11	500	2,000	
NATK681M25V12.5X14KLBYF	680		0.16	0.08	1200	3,000	
NATK911M25V12.5X14KLBYF	910		0.16	0.08	1200	3,000	
NATK102M25V16X17JLSYF	1000		0.16	0.05	1800	5,000	
NATK152M25V16X17JLSYF	1500		0.16	0.05	1800	5,000	
NATK222M25V18X17.5JLSYF	2200		0.18	0.045	2000	5,000	
NATK332M25V18X22JLSYF	3300		0.20	0.040	2200	5,000	
NATK220M35V6.3X6.3NLBYF	22		35	0.14	1.60	110	2,000
NATK330M35V6.3X6.3NLBYF	33			0.14	1.60	110	2,000
NATK330M35V6.3X8NLBYF	33	0.14		0.45	200	2,000	
NATK470M35V6.3X8NLBYF	47	0.14		0.45	200	2,000	
NATK101M35V8X10.8NLBYF	100	0.14		0.18	300	2,000	
NATK161M35V8X10.8NLBYF	160	0.14		0.18	300	2,000	
NATK221M35V10X10.8LLBYF	220	0.14		0.11	500	2,000	
NATK301M35V10X10.8LLBYF	300	0.14		0.11	500	2,000	
NATK331M35V12.5X14KLBYF	330	0.14		0.08	1200	3,000	
NATK471M35V12.5X14KLBYF	470	0.14		0.08	1200	3,000	
NATK621M35V12.5X14KLBYF	620	0.14		0.08	1200	3,000	
NATK681M35V16X17JLSYF	680	0.14		0.05	1800	5,000	
NATK102M35V16X17JLSYF	1000	0.14		0.05	1800	5,000	
NATK152M35V18X17.5JLSYF	1500	0.14		0.045	2000	5,000	
NATK222M35V18X22JLSYF	2200	0.16		0.040	2200	5,000	
NATK100M50V6.3X6.3NLBYF	10	50		0.14	2.00	70	2000
NATK470M50V8X10.8NLBYF	47		0.14	0.45	250	2000	
NATK101M50V10X10.8LLBYF	100		0.14	0.30	350	2000	
NATK221M50V12.5X14KLBYF	220		0.14	0.15	700	3000	
NATK471M50V16X17JLSYF	470		0.14	0.09	1000	5000	
NATK681M50V18X17.5JLSYF	680		0.14	0.07	1200	5000	
NATK102M50V18X22JLSYF	1000		0.14	0.05	1650	5000	

RIPPLE CURRENT FREQUENCY CORRECTION FACTOR

Frequency (Hz)	100 ≤ f < 1K	1K ≤ f < 10K	10K ≤ f < 100K	100K ≤ f
10μF ~ 3900μF	0.60	0.85	0.93	1.00



Surface Mount Aluminum Electrolytic Capacitors NATK Series

PART NUMBER SYSTEM

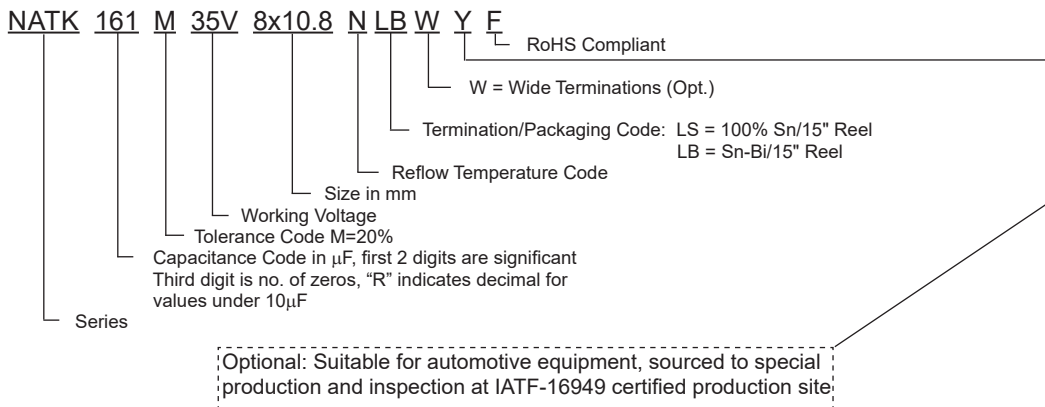

STANDARD TERMINATIONS LAND PATTERN DIMENSIONS (mm)

Case Size	a	b	c
6.3x6.3	1.8	3.6	1.8
6.3x8	1.8	3.6	1.8
8x10.8	2.8	4.1	2.1
10x10.8	4.3	4.4	2.5
12.5x14	4.3	5.8	2.5
16x17	6.6	6.5	5.0
18x17	6.6	7.7	5.0
18x22	6.6	7.7	5.0

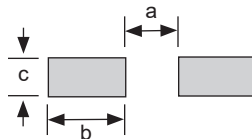

W (WIDE TERMINATIONS) COMPONENT DIM. (mm)

Case Size	D ϕ \pm 0.5	L max.	A, B \pm 0.2	C \pm 0.2	P \pm 0.2	W	R	T
6.3x6.3								
6.3x8								
8x10.8	8.0	11.2	8.3	9.0	3.2	0.7 ~ 1.0 (0.7)	(1.3)	
10x10.8	10.0	11.2	10.3	11.0	4.6	1.0 ~ 1.4 (0.7)	(1.3)	
12.5x14	12.5	14.5	13.5	14.2	4.6	1.0 ~ 1.4 (2.2)	(2.4)	
16x17	16.0	17.5	17.0	18.0	7.0	1.7 ~ 2.1 (3.0)	(2.0)	
18x17.5	18.0	17.5	19.0	20.0	7.0	1.7 ~ 2.1 (3.0)	(2.0)	
18x22		22.5						

W (WIDE TERMINATIONS) LAND PATTERN DIM. (mm)

Case Size	a	b	c
6.3x6.3			
6.3x8			
8x10.8	2.5	4.5	4.7
10x10.8	3.8	4.8	4.7
12.5x14	3.8	6.1	6.9
16x17	5.0	8.0	9.5
18x17.5	5.0	8.6	9.5
18x22			

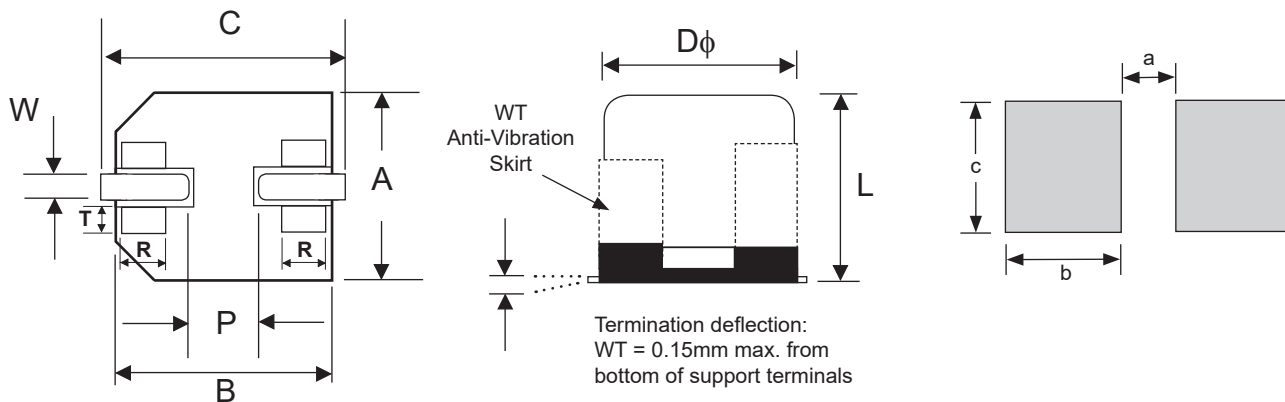

W (Wide Terminations) Anti-Vibration Test	
Test Method	Direction: X, Y, Z axis Frequency & Duration: 5 to 2000Hz reciprocation for 20 minutes, 2 hours each direction Peak to Peak Amplitude: 5mm Peak Acceleration: 30G Sweep Type: Log
Δ Capacitance	Within \pm 10% of initial value
Tangent of Loss	\leq Specified value
Leakage Current	\leq Specified value



PEAK REFLOW TEMPERATURES AND DURATION

Diameter	Time above 200°C	Time above 217°C	Time above 230°C	Peak Temperature 5 seconds
6.3mm & 8mm ϕ	80 sec. max.	70 sec. max.	40 sec. max.	260°C
10mm ϕ	70 sec. max.	60 sec. max.	40 sec. max.	250°C
12.5mm ϕ	60 sec. max.	50 sec. max.	30 sec. max.	245°C
16mm & 18mm ϕ	50 sec. max.	40 sec. max.	20 sec. max.	240°C

Capacitors can withstand two reflow passes under the specified conditions. Capacitors must be allowed to cool to room temperature before the second reflow pass.

Review & Compare Reflow Soldering Heat Limits
V-chip SMT Aluminum Electrolytic Capacitors
www.niccomp.com/RSL

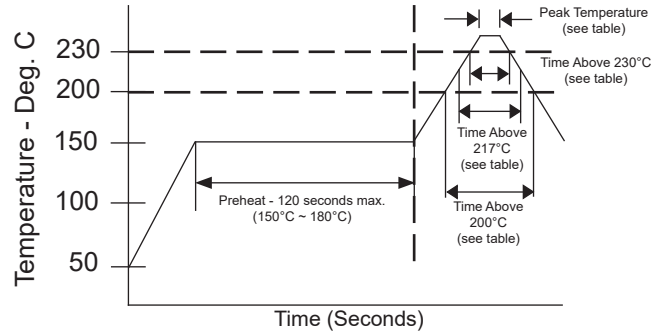

CARRIER TAPE

Case Size	A ± 0.2	B ± 0.2	C ± 0.3	D ± 0.1	P ± 0.1	T ± 0.2	t max.	s ± 0.1
6.3x6.3	7.0	7.0	16.0	7.5	12.0	6.5	0.6	-
6.3x8	7.0	7.0	16.0	7.5	12.0	8.2	0.6	-
8x10.8	8.7	8.7	24.0	11.5	16.0	11.1	0.6	-
10x10.8	10.7	10.7	24.0	11.5	16.0	11.2	0.6	-
12.5x14	13.2	13.2	32.0	14.2	24.0	14.3	0.6	28.4
16x17	17.5	17.5	44.0	20.2	28.0	17.3	0.6	40.4
18x17.5	19.5	19.5	44.0	20.2	32.0	17.8	0.6	40.4
18x22	19.5	19.5	44.0	20.2	32.0	22.5	0.6	40.4

TAPING SPECIFICATIONS (mm)

- Both Leader and Trailer tape: Minimum 10 empty carrier tape pockets.
- Leader tape: Approximately 20cm of cover tape at leader.
- Connection: Maximum 3 connections (slices) per reel.

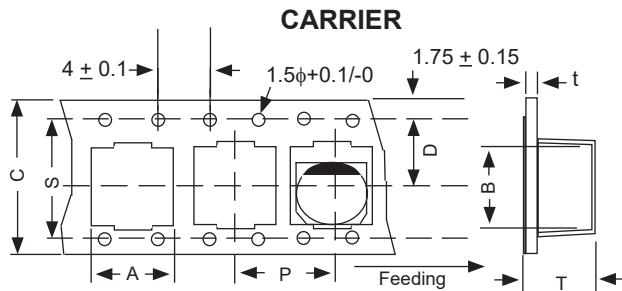

Surface Mount Aluminum Electrolytic Capacitors NATK Series

Preferred V-Chip 15" (380mm) Reels (LB suffix)

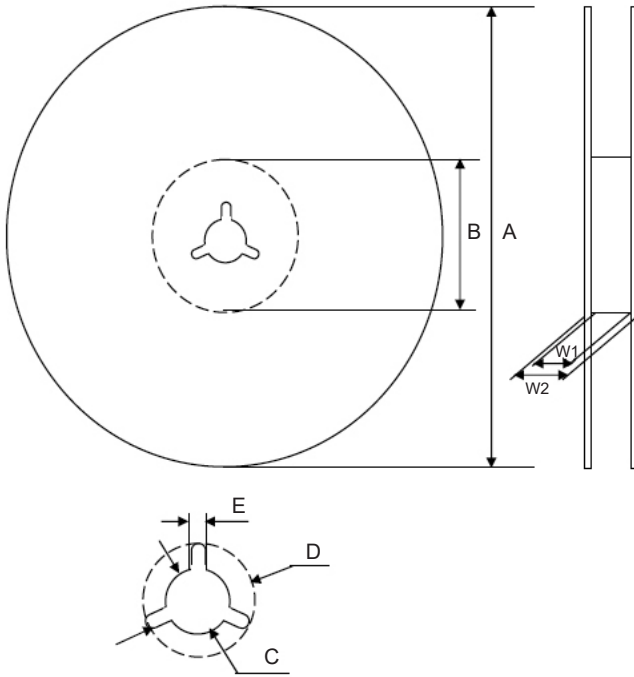

Dimensions (mm)

Case Size	Tape Width	W1	W2
6.3x6.3, 6.3x8	16.0	16.5 ~ 18.0	19.5 ~ 24.0
8x10.8, 10x10.8	24.0	24.5 ~ 26.0	27.5 ~ 32.0
12.5x14	32.0	33.0 ~ 34.0	36.5 ~ 38.5
16x17, 18x17.5, 18x22	44.0	45.0 ~ 46.0	48.5 ~ 50.5

Case Size	Tape Width	A	B	C	D	E
6.3x6.3, 6.3x8	16.0	$\phi 380$ ± 2	$\phi 80 \sim 105$	$\phi 13$ ± 0.5	$\phi 21$ ± 1.0	2.0 ± 0.5
8x10.8, 10x10.8	24.0					
12.5x14	32.0					
16x17, 18x17.5, 18x22	44.0					

Color
Black or Blue

Case Size	Qty per Reel 15" (380mm)
6.3x6.3	1000
6.3x8	900
8x10.8	500
10x10.8	500
12.5x14	250
16x17	200
18x17.5	175
18x22	125

