



## DM54145/DM74145 BCD to Decimal Decoders/Drivers

### General Description

These BCD-to-decimal decoders/drivers consist of eight inverters and ten, four-input NAND gates. The inverters are connected in pairs to make BCD input data available for decoding by the NAND gates. Full decoding of BCD input logic ensures that all outputs remain off for all invalid (10–15) binary input conditions. These decoders feature high-performance, NPN output transistors designed for use as indicator/relay drivers, or as open-collector logic-circuit drivers. The high-breakdown output transistors are compatible for interfacing with most MOS integrated circuits.

### Features

- Full decoding of input logic
- 80 mA sink-current capability
- All outputs are off for invalid BCD input conditions

### Connection Diagram

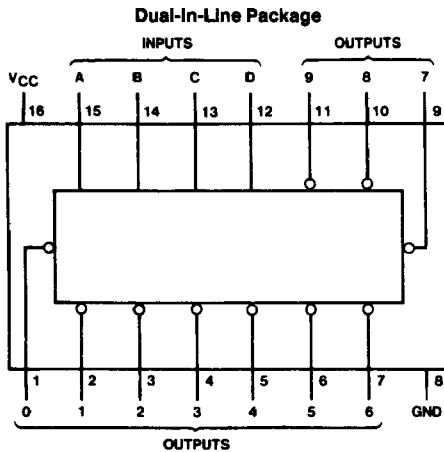

TL/F/6544-1

Order Number DM54145J, DM54145W or DM74145N  
See NS Package Number J16A, N16E or W16A

### Function Table

No.	Inputs				Outputs									
	D	C	B	A	0	1	2	3	4	5	6	7	8	9
0	L	L	L	L	L	H	H	H	H	H	H	H	H	H
1	L	L	L	H	H	L	H	H	H	H	H	H	H	H
2	L	L	H	L	H	H	L	H	H	H	H	H	H	H
3	L	L	H	H	H	H	H	L	H	H	H	H	H	H
4	L	H	L	L	H	H	H	H	L	H	H	H	H	H
5	L	H	L	H	H	H	H	H	H	L	H	H	H	H
6	L	H	H	L	H	H	H	H	H	H	L	H	H	H
7	L	H	H	H	H	H	H	H	H	H	H	L	H	H
8	H	L	L	L	H	H	H	H	H	H	H	H	L	H
9	H	L	L	H	H	H	H	H	H	H	H	H	H	L
I	H	L	H	L	H	H	H	H	H	H	H	H	H	H
N	H	L	H	H	H	H	H	H	H	H	H	H	H	H
V	H	H	L	L	H	H	H	H	H	H	H	H	H	H
A	H	H	L	H	H	H	H	H	H	H	H	H	H	H
L	H	H	H	L	H	H	H	H	H	H	H	H	H	H
I	H	H	H	H	H	H	H	H	H	H	H	H	H	H
D														

H = High Level (Off), L = Low Level (On)

## Absolute Maximum Ratings (Note)

If Military/Aerospace specified devices are required, please contact the National Semiconductor Sales Office/Distributors for availability and specifications.

Supply Voltage	7V
Input Voltage	5.5V
Operating Free Air Temperature Range	
DM54	-55°C to +125°C
DM74	0°C to +70°C
Storage Temperature Range	-65°C to +150°C

Note: The "Absolute Maximum Ratings" are those values beyond which the safety of the device cannot be guaranteed. The device should not be operated at these limits. The parametric values defined in the "Electrical Characteristics" table are not guaranteed at the absolute maximum ratings. The "Recommended Operating Conditions" table will define the conditions for actual device operation.

## Recommended Operating Conditions

Symbol	Parameter	DM54145			DM74145			Units
		Min	Nom	Max	Min	Nom	Max	
V <sub>CC</sub>	Supply Voltage	4.5	5	5.5	4.75	5	5.25	V
V <sub>IH</sub>	High Level Input Voltage	2			2			V
V <sub>IL</sub>	Low Level Input Voltage			0.8			0.8	V
V <sub>OH</sub>	High Level Output Voltage			15			15	V
I <sub>OL</sub>	Low Level Output Current			20			20	mA
T <sub>A</sub>	Free Air Operating Temperature	-55		125	0		70	°C

## Electrical Characteristics over recommended operating free air temperature range (unless otherwise noted)

Symbol	Parameter	Conditions	Min	Typ (Note 1)	Max	Units
V <sub>I</sub>	Input Clamp Voltage	V <sub>CC</sub> = Min, I <sub>I</sub> = -12 mA			-1.5	V
I <sub>CEX</sub>	High Level Output Current	V <sub>CC</sub> = Min, V <sub>OH</sub> = Max V <sub>IL</sub> = Max, V <sub>IH</sub> = Min			250	μA
V <sub>OL</sub>	Low Level Output Voltage	V <sub>CC</sub> = Min, I <sub>OL</sub> = Max V <sub>IH</sub> = Min, V <sub>IL</sub> = Max			0.4	V
		I <sub>OL</sub> = 80 mA V <sub>CC</sub> = Min		0.5	0.9	
I <sub>I</sub>	Input Current @ Max Input Voltage	V <sub>CC</sub> = Max, V <sub>I</sub> = 5.5V			1	mA
I <sub>IH</sub>	High Level Input Current	V <sub>CC</sub> = Max, V <sub>I</sub> = 2.4V			40	μA
I <sub>IL</sub>	Low Level Input Current	V <sub>CC</sub> = Max, V <sub>I</sub> = 0.4V			-1.6	mA
I <sub>CC</sub>	Supply Current	V <sub>CC</sub> = Max (Note 2)	DM54	43	62	mA
			DM74	43	70	

## Switching Characteristics at V<sub>CC</sub> = 5V and T<sub>A</sub> = 25°C (See Section 1 for Test Waveforms and Output Load)

Symbol	Parameter	Conditions	Min	Max	Units
t <sub>PLH</sub>	Propagation Delay Time Low to High Level Output	C <sub>L</sub> = 15 pF R <sub>L</sub> = 100Ω		30	ns
				30	
t <sub>PHL</sub>	Propagation Delay Time High to Low Level Output			30	ns

Note 1: All typicals are at V<sub>CC</sub> = 5V, T<sub>A</sub> = 25°C.

Note 2: I<sub>CC</sub> is measured with all outputs open and all inputs grounded.

# Logic Diagram

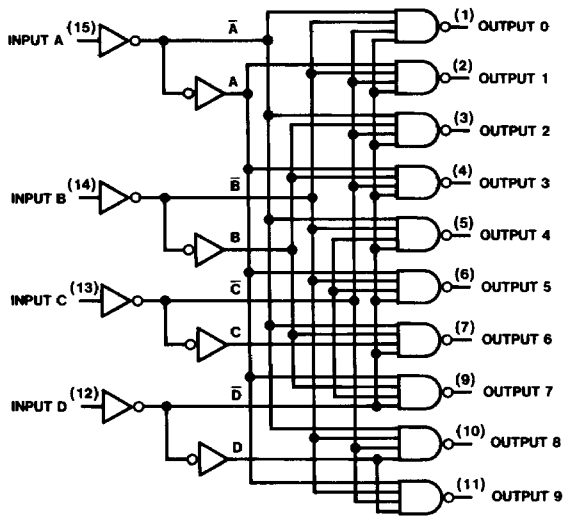

TL/F/6544-2