

# CD4028BM/CD4028BC BCD-to-Decimal Decoder

## General Description

The CD4028BM/CD4028BC is a BCD-to-decimal or binary-to-octal decoder consisting of 4 inputs, decoding logic gates, and 10 output buffers. A BCD code applied to the 4 inputs, A, B, C, and D, results in a high level at the selected 1-of-10 decimal decoded outputs. Similarly, a 3-bit binary code applied to inputs A, B, and C is decoded in octal at outputs 0-7. A high level signal at the D input inhibits octal decoding and causes outputs 0-7 to go low.

All inputs are protected against static discharge damage by diode clamps to  $V_{DD}$  and  $V_{SS}$ .

## Features

- Wide supply voltage range
- High noise immunity
- Low power TTL compatibility
- Low power
- Glitch free outputs
- "Positive logic" on inputs and outputs

3.0V to 15V  
0.45  $V_{DD}$  (typ.)  
fan out of 2 driving 74L  
or 1 driving 74LS

## Applications

- Code conversion
- Address decoding
- Indicator-tube decoder

## Logic and Connection Diagrams

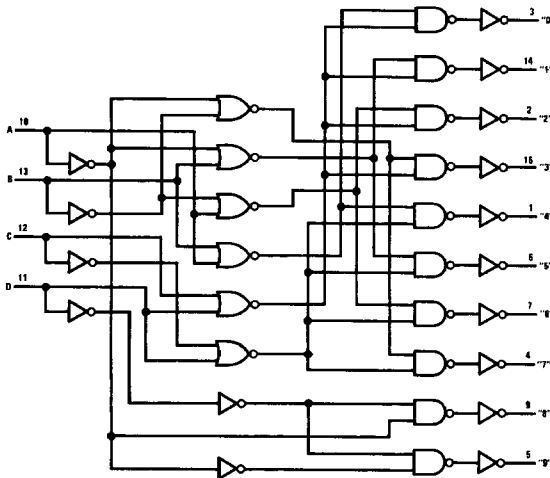

TL/F/5959-1

## Dual-In-Line Package

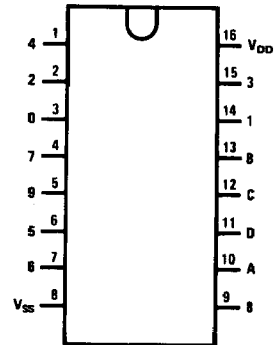

TL/F/5959-2

## Top View

### Order Number CD4028B\*

\*Please look into Section 8, Appendix D for availability of various package types.

## Truth Table

1 = High Level  
0 = Low Level

D	C	B	A	0	1	2	3	4	5	6	7	8	9
0	0	0	0	1	0	0	0	0	0	0	0	0	0
0	0	0	1	0	1	0	0	0	0	0	0	0	0
0	0	1	0	0	0	1	0	0	0	0	0	0	0
0	0	1	1	0	0	0	1	0	0	0	0	0	0
0	1	0	0	0	0	0	0	1	0	0	0	0	0
0	1	0	1	0	0	0	0	0	1	0	0	0	0
0	1	1	0	0	0	0	0	0	0	1	0	0	0
0	1	1	1	0	0	0	0	0	0	0	1	0	0
1	0	0	0	0	0	0	0	0	0	0	0	1	0
1	0	0	1	0	0	0	0	0	0	0	0	0	1
1	0	1	0	0	0	0	0	0	0	0	0	0	1
1	0	1	1	0	0	0	0	0	0	0	0	0	1
1	1	0	0	0	0	0	0	0	0	0	0	0	1
1	1	0	1	0	0	0	0	0	0	0	0	0	1
1	1	1	0	0	0	0	0	0	0	0	0	0	1
1	1	1	1	0	0	0	0	0	0	0	0	0	1

BCD States

Extraordinary States

**Absolute Maximum Ratings** (Notes 1 & 2)

If Military/Aerospace specified devices are required, contact the National Semiconductor Sales Office/Distributors for availability and specifications.

Supply Voltage (V <sub>DD</sub> )	-0.5 to +18V
Input Voltage (V <sub>IN</sub> )	-0.5 to V <sub>DD</sub> + 0.5V
Storage Temperature Range (T <sub>S</sub> )	-65°C to +150°C
Power Dissipation (P <sub>D</sub> )	
Dual-In-Line	700 mW
Small Outline	500 mW
Lead Temperature (T <sub>L</sub> )	
(Soldering, 10 seconds)	260°C

**Recommended Operating Conditions** (Note 2)

Supply Voltage (V <sub>DD</sub> )	3 to 15V
Input Voltage (V <sub>IN</sub> )	0 to V <sub>DD</sub> V
Operating Temperature Range (T <sub>A</sub> )	
CD4028BM	-55°C to +125°C
CD4028BC	-40°C to +185°C

**DC Electrical Characteristics** CD4028BC (Note 2)

Symbol	Parameter	Conditions	-55°C		+25°C			+125°C		Units
			Min	Max	Min	Typ	Max	Min	Max	
I <sub>DD</sub>	Quiescent Device Current	V <sub>DD</sub> = 5V, V <sub>IN</sub> = V <sub>DD</sub> or V <sub>SS</sub>		5		0.01	5		150	μA
		V <sub>DD</sub> = 10V, V <sub>IN</sub> = V <sub>DD</sub> or V <sub>SS</sub>		10		0.01	10		300	μA
		V <sub>DD</sub> = 15V, V <sub>IN</sub> = V <sub>DD</sub> or V <sub>SS</sub>		20		0.02	20		600	μA
V <sub>OL</sub>	Low Level Output Voltage	I <sub>O</sub>   < 1 μA, V <sub>IL</sub> = 0V, V <sub>IH</sub> = V <sub>DD</sub>								
		V <sub>DD</sub> = 5V		0.05		0	0.05		0.05	V
		V <sub>DD</sub> = 10V		0.05		0	0.05		0.05	V
V <sub>OH</sub>	High Level Output Voltage	I <sub>O</sub>   < 1 μA, V <sub>IL</sub> = 0V, V <sub>IH</sub> = V <sub>DD</sub>								
		V <sub>DD</sub> = 5V	4.95		4.95	5		4.95		V
		V <sub>DD</sub> = 10V	9.95		9.95	10		9.95		V
V <sub>IL</sub>	Low Level Input Voltage	I <sub>O</sub>   < 1 μA								
		V <sub>DD</sub> = 5V, V <sub>O</sub> = 0.5V or 4.5V		1.5		2.25	1.5		1.5	V
		V <sub>DD</sub> = 10V, V <sub>O</sub> = 1V or 9V		3.0		4.5	3.0		3.0	V
V <sub>IH</sub>	High Level Input Voltage	I <sub>O</sub>   < 1 μA								
		V <sub>DD</sub> = 5V, V <sub>O</sub> = 0.5V or 4.5V	3.5		3.5	2.75		3.5		V
		V <sub>DD</sub> = 10V, V <sub>O</sub> = 1V or 9V	7.0		7.0	5.5		7.0		V
I <sub>OL</sub>	Low Level Output Current (Note 3)	V <sub>IL</sub> = 0V, V <sub>IH</sub> = V <sub>DD</sub>								
		V <sub>DD</sub> = 5V, V <sub>O</sub> = 0.4V	0.64		0.51	1.0		0.36		mA
		V <sub>DD</sub> = 10V, V <sub>O</sub> = 0.5V	1.6		1.3	2.6		0.9		mA
I <sub>OH</sub>	High Level Output Current (Note 3)	V <sub>IL</sub> = 0V, V <sub>IH</sub> = V <sub>DD</sub>								
		V <sub>DD</sub> = 5V, V <sub>O</sub> = 4.6V	-0.25		-0.2	-0.4		-0.14		mA
		V <sub>DD</sub> = 10V, V <sub>O</sub> = 9.5V	-0.62		-0.5	-1.0		-0.35		mA
I <sub>IN</sub>	Input Current	V <sub>DD</sub> = 15V, V <sub>IN</sub> = 0V		-0.1		-10 <sup>-5</sup>	-0.1		-1.0	μA
		V <sub>DD</sub> = 15V, V <sub>IN</sub> = 15V		0.1		10 <sup>-5</sup>	0.1		1.0	μA

**DC Electrical Characteristics** CD4028BC (Note 2)

Symbol	Parameter	Conditions	-40°C		+25°C			+85°C		Units
			Min	Max	Min	Typ	Max	Min	Max	
I <sub>DD</sub>	Quiescent Device Current	V <sub>DD</sub> = 5V, V <sub>IN</sub> = V <sub>DD</sub> or V <sub>SS</sub>		20		0.01	20		150	μA
		V <sub>DD</sub> = 10V, V <sub>IN</sub> = V <sub>DD</sub> or V <sub>SS</sub>		40		0.01	40		300	μA
		V <sub>DD</sub> = 15V, V <sub>IN</sub> = V <sub>DD</sub> or V <sub>SS</sub>		80		0.02	80		600	μA
V <sub>OL</sub>	Low Level Output Voltage	I <sub>O</sub>   < 1 μA, V <sub>IL</sub> = 0V, V <sub>IH</sub> = V <sub>DD</sub>								
		V <sub>DD</sub> = 5V		0.05		0	0.05		0.05	V
		V <sub>DD</sub> = 10V		0.05		0	0.05		0.05	V
V <sub>OH</sub>	High Level Output Voltage	I <sub>O</sub>   < 1 μA, V <sub>IL</sub> = 0V, V <sub>IH</sub> = V <sub>DD</sub>								
		V <sub>DD</sub> = 5V		0.05		0	0.05		0.05	V
		V <sub>DD</sub> = 10V		0.05		0	0.05		0.05	V

## DC Electrical Characteristics CD4028BC (Note 2) (Continued)

Symbol	Parameter	Conditions	-40°C		+25°C			+85°C		Units
			Min	Max	Min	Typ	Max	Min	Max	
V <sub>OH</sub>	High Level Output Voltage	I <sub>O</sub>   < 1 μA, V <sub>IL</sub> = 0V, V <sub>IH</sub> = V <sub>DD</sub> V <sub>DD</sub> = 5V V <sub>DD</sub> = 10V V <sub>DD</sub> = 15V	4.95		4.95	5		4.95		V
			9.95		9.95	10		9.95		V
			14.95		14.95	15		14.95		V
V <sub>IL</sub>	Low Level Input Voltage	I <sub>O</sub>   < 1 μA V <sub>DD</sub> = 5V, V <sub>O</sub> = 0.5V or 4.5V V <sub>DD</sub> = 10V, V <sub>O</sub> = 1V or 9V V <sub>DD</sub> = 15V, V <sub>O</sub> = 1.5V or 13.5V		1.5		2.25	1.5		1.5	V
				3.0		4.5	3.0		3.0	V
				4.0		6.75	4.0		4.0	V
V <sub>IH</sub>	High Level Input Voltage	I <sub>O</sub>   < 1 μA V <sub>DD</sub> = 5V, V <sub>O</sub> = 0.5V or 4.5V V <sub>DD</sub> = 10V, V <sub>O</sub> = 1V or 9V V <sub>DD</sub> = 15V, V <sub>O</sub> = 1.5V or 13.5V	3.5		3.5			3.5		V
			7.0		7.0			7.0		V
			11.0		11.0			11.0		V
I <sub>OL</sub>	Low Level Output Current (Note 3)	V <sub>IH</sub> = V <sub>DD</sub> , V <sub>IL</sub> = 0V V <sub>DD</sub> = 5V, V <sub>O</sub> = 0.4V V <sub>DD</sub> = 10V, V <sub>O</sub> = 0.5V V <sub>DD</sub> = 15V, V <sub>O</sub> = 1.5V	0.52		0.44	0.88		0.36		mA
			1.3		1.1	2.2		0.9		mA
			3.6		3.0	6.0		2.4		mA
I <sub>OH</sub>	High Level Output Current (Note 3)	V <sub>IH</sub> = V <sub>DD</sub> , V <sub>IL</sub> = 0V V <sub>DD</sub> = 5V, V <sub>O</sub> = 4.6V V <sub>DD</sub> = 10V, V <sub>O</sub> = 9.5V V <sub>DD</sub> = 15V, V <sub>O</sub> = 13.5V	-0.2		-0.16	-0.32		-0.12		mA
			-0.5		-0.4	-0.8		-0.3		mA
			-1.4		-1.2	-3.5		-1.0		mA
I <sub>IN</sub>	Input Current	V <sub>DD</sub> = 15V, V <sub>IN</sub> = 0V V <sub>DD</sub> = 15V, V <sub>IN</sub> = 15V		-0.3				-0.3		μA
				0.3				0.3		1.0

## AC Electrical Characteristics\*

T<sub>A</sub> = 25°C, C<sub>L</sub> = 50 pF, R<sub>L</sub> = 200k, Input t<sub>r</sub> = t<sub>f</sub> = 20 ns, unless otherwise specified

Symbol	Parameter	Conditions	Min	Typ	Max	Units
t <sub>PHL</sub> or t <sub>PLH</sub>	Propagation Delay Time	V <sub>CC</sub> = 5V		240	480	ns
		V <sub>CC</sub> = 10V		100	200	ns
		V <sub>CC</sub> = 15V		70	140	ns
t <sub>THL</sub> or t <sub>TLH</sub>	Transition Time	V <sub>CC</sub> = 5V		175	350	ns
		V <sub>CC</sub> = 10V		75	150	ns
		V <sub>CC</sub> = 15V		60	110	ns
C <sub>IN</sub>	Input Capacitance	Any Input		5	7.5	pF

\* AC Parameters are guaranteed by DC correlated testing.

**Note 1:** "Absolute Maximum Ratings" are those values beyond which the safety of the device cannot be guaranteed, they are not meant to imply that the devices should be operated at these limits. The table of "Recommended Operating Conditions" and "Electrical Characteristics" provides conditions for actual device operation.

**Note 2:** V<sub>SS</sub> = 0V unless otherwise specified.

**Note 3:** I<sub>OL</sub> and I<sub>OH</sub> are tested one output at a time.

## Switching Time Waveforms

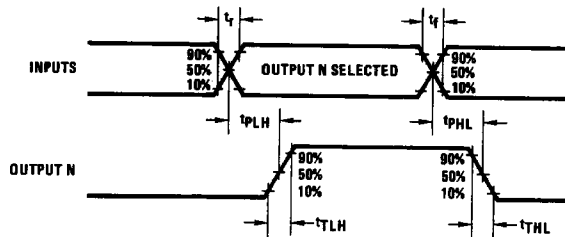

TL/F/5959-3