

MM54HC154/MM74HC154 4-to-16 Line Decoder

General Description

This decoder utilizes advanced silicon-gate CMOS technology, and is well suited to memory address decoding or data routing applications. It possesses high noise immunity, and low power consumption of CMOS with speeds similar to low power Schottky TTL circuits.

The MM54HC154/MM74HC154 have 4 binary select inputs (A, B, C, and D). If the device is enabled these inputs determine which one of the 16 normally high outputs will go low. Two active low enables ($\overline{G1}$ and $\overline{G2}$) are provided to ease cascading of decoders with little or no external logic.

Each output can drive 10 low power Schottky TTL equivalent loads, and is functionally and pin equivalent to the 54LS154/74LS154. All inputs are protected from damage due to static discharge by diodes to V_{CC} and ground.

Features

- Typical propagation delay: 21 ns
- Power supply quiescent current: 80 μA (74HC)
- Wide power supply voltage range: 2–6V
- Low input current: 1 μA maximum

Connection Diagram

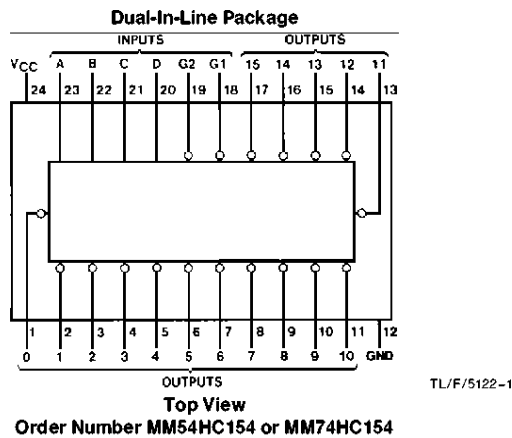

Truth Table

		Inputs				Low Output*
$\overline{G1}$	$\overline{G2}$	D	C	B	A	
L	L	L	L	L	L	0
L	L	L	L	L	H	1
L	L	L	L	H	L	2
L	L	L	L	H	H	3
L	L	L	H	L	L	4
L	L	L	H	L	H	5
L	L	L	H	H	L	6
L	L	L	H	H	H	7
L	L	H	L	L	L	8
L	L	H	L	L	H	9
L	L	H	L	H	L	10
L	L	H	L	H	H	11
L	L	H	H	L	L	12
L	L	H	H	L	H	13
L	L	H	H	H	L	14
L	L	H	H	H	H	15
L	H	X	X	X	X	—
H	L	X	X	X	X	—
H	H	X	X	X	X	—

*All others high

Absolute Maximum Ratings (Notes 1 & 2)
If Military/Aerospace specified devices are required, please contact the National Semiconductor Sales Office/Distributors for availability and specifications.

Supply Voltage (V_{CC})	-0.5 to +7.0V
DC Input Voltage (V_{IN})	-1.5 to $V_{CC} + 1.5V$
DC Output Voltage (V_{OUT})	-0.5 to $V_{CC} + 0.5V$
Clamp Diode Current (I_{IK}, I_{OK})	± 20 mA
DC Output Current, per pin (I_{OUT})	± 25 mA
DC V_{CC} or GND Current, per pin (I_{CC})	± 50 mA
Storage Temperature Range (T_{STG})	-65°C to +150°C
Power Dissipation (P_D) (Note 3)	600 mW
S.O. Package only	500 mW
Lead Temp. (T_L) (Soldering 10 seconds)	260°C

Operating Conditions

	Min	Max	Units
Supply Voltage (V_{CC})	2	6	V
DC Input or Output Voltage (V_{IN}, V_{OUT})	0	V_{CC}	V
Operating Temp. Range (T_A)			
MM74HC	-40	+85	°C
MM54HC	-55	+125	°C
Input Rise or Fall Times (t_r, t_f)			
$V_{CC}=2.0V$		1000	ns
$V_{CC}=4.5V$		500	ns
$V_{CC}=6.0V$		400	ns

DC Electrical Characteristics (Note 4)

Symbol	Parameter	Conditions	V_{CC}	$T_A = 25^\circ C$		74HC	54HC	Units
						$T_A = -40$ to $85^\circ C$	$T_A = -55$ to $125^\circ C$	
				Typ	Guaranteed Limits			
V_{IH}	Minimum High Level Input Voltage		2.0V		1.5	1.5	1.5	V
			4.5V		3.15	3.15	3.15	V
			6.0V		4.2	4.2	4.2	V
V_{IL}	Maximum Low Level Input Voltage**		2.0V		0.5	0.5	0.5	V
			4.5V		1.35	1.35	1.35	V
			6.0V		1.8	1.8	1.8	V
V_{OH}	Minimum High Level Output Voltage	$V_{IN} = V_{IH}$ or V_{IL} $ I_{OUT} \leq 20 \mu A$	2.0V	2.0	1.9	1.9	1.9	V
			4.5V	4.5	4.4	4.4	4.4	V
			6.0V	6.0	5.9	5.9	5.9	V
		$V_{IN} = V_{IH}$ or V_{IL} $ I_{OUT} \leq 4.0$ mA $ I_{OUT} \leq 5.2$ mA	4.5V	4.2	3.98	3.84	3.7	V
			6.0V	5.7	5.48	5.34	5.2	V
V_{OL}	Maximum Low Level Output Voltage	$V_{IN} = V_{IH}$ or V_{IL} $ I_{OUT} \leq 20 \mu A$	2.0V	0	0.1	0.1	0.1	V
			4.5V	0	0.1	0.1	0.1	V
			6.0V	0	0.1	0.1	0.1	V
		$V_{IN} = V_{IH}$ or V_{IL} $ I_{OUT} \leq 4.0$ mA $ I_{OUT} \leq 5.2$ mA	4.5V	0.2	0.26	0.33	0.4	V
			6.0V	0.2	0.26	0.33	0.4	V
I_{IN}	Maximum Input Current	$V_{IN} = V_{CC}$ or GND	6.0V		± 0.1	± 1.0	± 1.0	μA
I_{CC}	Maximum Quiescent Supply Current	$V_{IN} = V_{CC}$ or GND $I_{OUT} = 0 \mu A$	6.0V		8.0	80	160	μA

Note 1: Absolute Maximum Ratings are those values beyond which damage to the device may occur.

Note 2: Unless otherwise specified all voltages are referenced to ground.

Note 3: Power Dissipation temperature derating — plastic "N" package: -12 mW/°C from 65°C to 85°C; ceramic "J" package: -12 mW/°C from 100°C to 125°C.

Note 4: For a power supply of 5V $\pm 10\%$ the worst case output voltages (V_{OH} , and V_{OL}) occur for HC at 4.5V. Thus the 4.5V values should be used when designing with this supply. Worst case V_{IH} and V_{IL} occur at $V_{CC} = 5.5V$ and 4.5V respectively. (The V_{IH} value at 5.5V is 3.85V.) The worst case leakage current (I_{IN} , I_{CC} , and I_{OZ}) occur for CMOS at the higher voltage and so the 6.0V values should be used.

** V_{IL} limits are currently tested at 20% of V_{CC} . The above V_{IL} specification (30% of V_{CC}) will be implemented no later than Q1, CY'89.

AC Electrical Characteristics $V_{CC}=5V$, $T_A=25^{\circ}C$, $C_L=15\text{ pF}$, $t_r=t_f=6\text{ ns}$

Symbol	Parameter	Conditions	Typ	Guaranteed Limit	Units
t_{PHL} , t_{PLH}	Maximum Propagation Delay, $\overline{G1}$, $\overline{G2}$ or A, B, C, D		21	32	ns

AC Electrical Characteristics $V_{CC}=2.0V$ to $6.0V$, $C_L=50\text{ pF}$, $t_r=t_f=6\text{ ns}$ (unless otherwise specified)

Symbol	Parameter	Conditions	V_{CC}	$T_A=25^{\circ}C$		74HC	54HC	Units
				Typ		$T_A=-40\text{ to }85^{\circ}C$	$T_A=-55\text{ to }125^{\circ}C$	
t_{PHL} , t_{PLH}	Maximum Propagation Delay, $\overline{G1}$ or $\overline{G2}$ or A, B, C, D		2.0V	63	160	190	220	ns
			4.5V	24	36	42	46	ns
			6.0V	20	30	35	39	ns
t_{TLH} , t_{THL}	Maximum Output Rise and Fall Time		2.0V	25	75	95	110	ns
			4.5V	7	15	19	22	ns
			6.0V	6	13	16	19	ns
C_{PD}	Power Dissipation Capacitance (Note 5)			90				pF
C_{IN}	Maximum Input Capacitance			5	10	10	10	pF

Note 5: C_{PD} determines the no load dynamic power consumption, $P_D=C_{PD} V_{CC}^2 f + I_{CC} V_{CC}$, and the no load dynamic current consumption, $I_S=C_{PD} V_{CC} f + I_{CC}$.

Logic Diagram

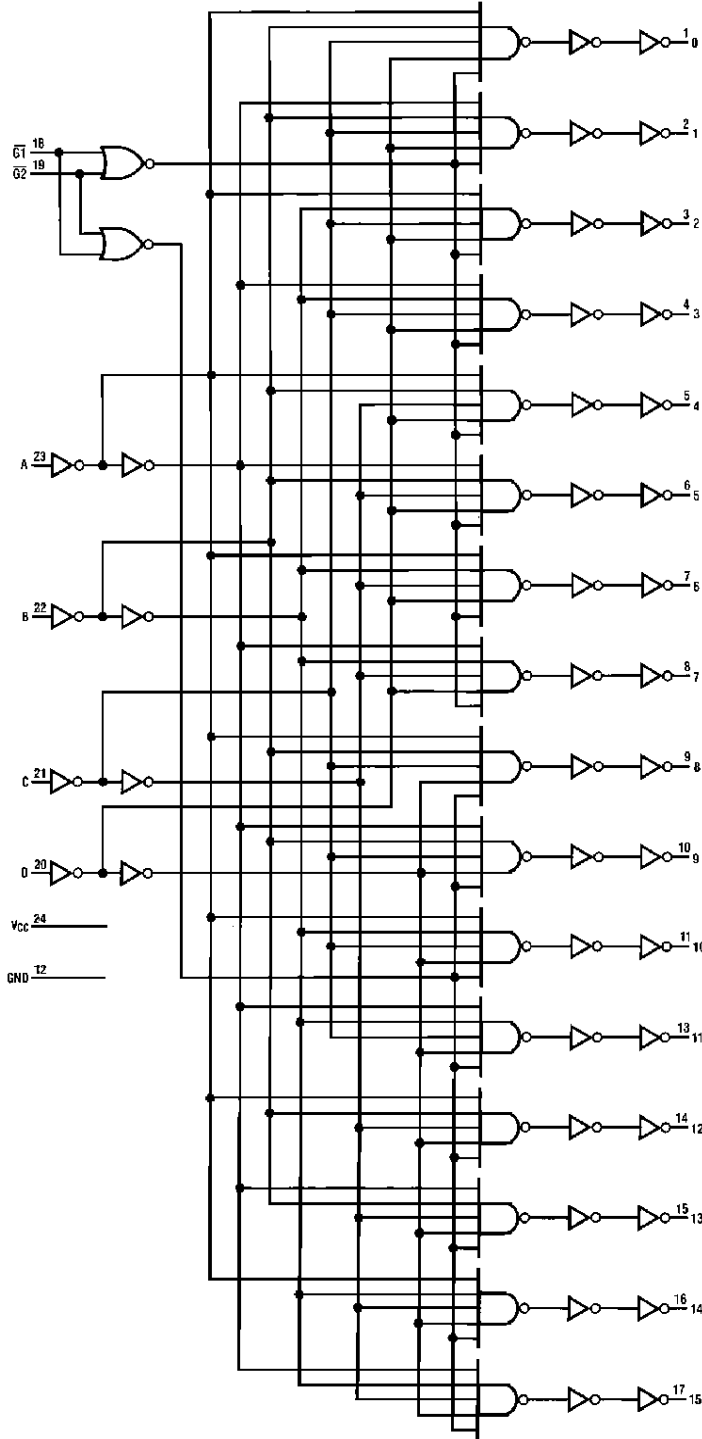

TL/F/5122-2

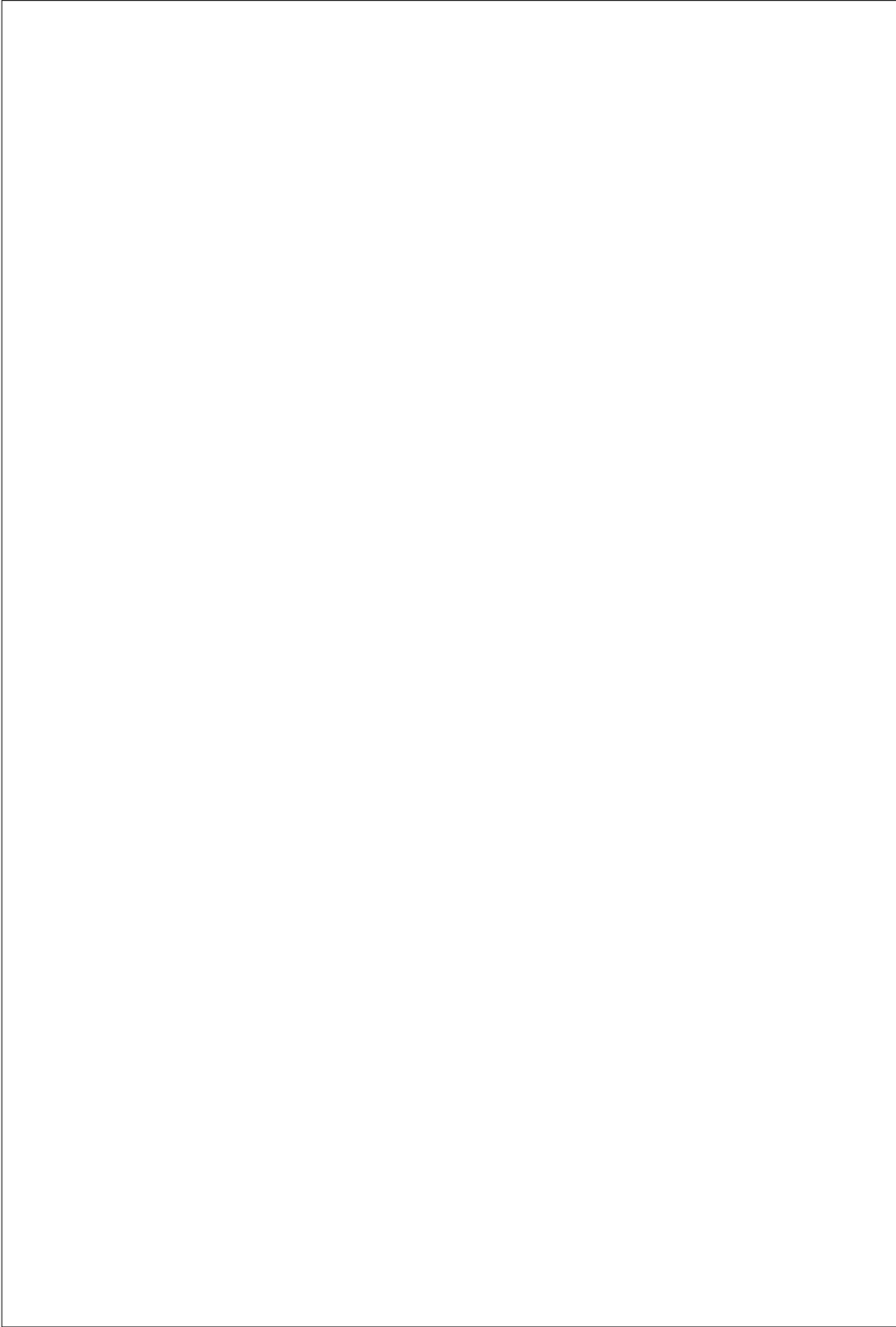

Physical Dimensions inches (millimeters)

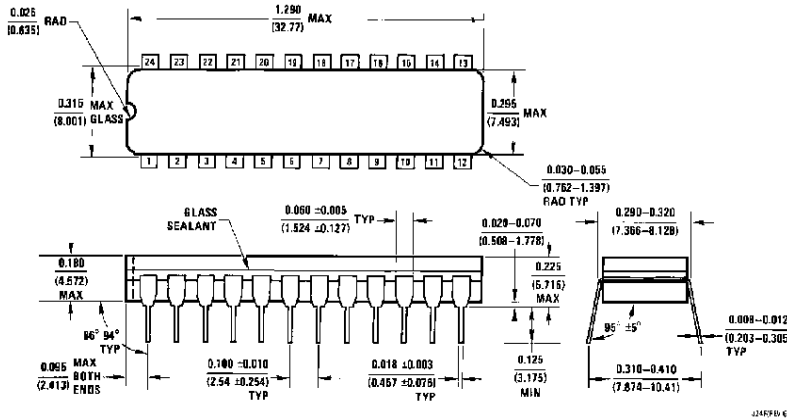

Order Number MM54HC154J or MM74HC154J
See NS Package J24F

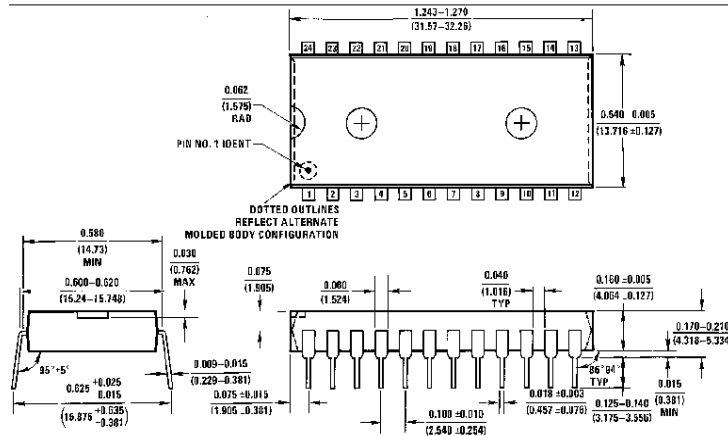

Order Number MM74HC154N
See NS Package N24C

LIFE SUPPORT POLICY

NATIONAL'S PRODUCTS ARE NOT AUTHORIZED FOR USE AS CRITICAL COMPONENTS IN LIFE SUPPORT DEVICES OR SYSTEMS WITHOUT THE EXPRESS WRITTEN APPROVAL OF THE PRESIDENT OF NATIONAL SEMICONDUCTOR CORPORATION. As used herein:

1. Life support devices or systems are devices or systems which, (a) are intended for surgical implant into the body, or (b) support or sustain life, and whose failure to perform, when properly used in accordance with instructions for use provided in the labeling, can be reasonably expected to result in a significant injury to the user.
2. A critical component is any component of a life support device or system whose failure to perform can be reasonably expected to cause the failure of the life support device or system, or to affect its safety or effectiveness.



National Semiconductor Corporation
1111 West Bardin Road
Arlington, TX 76017
Tel: 1(800) 272-9959
Fax: 1(800) 737-7018

National Semiconductor Europe
Fax: (+49) 0-180-530 85 86
Email: cnjwge@tevm2.nsc.com
Deutsch Tel: (+49) 0-180-530 85 85
English Tel: (+49) 0-180-532 78 32
Français Tel: (+49) 0-180-532 93 58
Italiano Tel: (+49) 0-180-534 16 80

National Semiconductor Hong Kong Ltd.
13th Floor, Straight Block,
Ocean Centre, 5 Canton Rd.
Tsimshatsui, Kowloon
Hong Kong
Tel: (852) 2737-1600
Fax: (852) 2736-9960

National Semiconductor Japan Ltd.
Tel: 81-043-299-2309
Fax: 81-043-299-2408

National does not assume any responsibility for use of any circuitry described, no circuit patent licenses are implied and National reserves the right at any time without notice to change said circuitry and specifications.