

54ACT823 9-Bit D Flip-Flop

General Description

The ACT823 is a 9-bit buffered register. It features Clock Enable and Clear which are ideal for parity bus interfacing in high performance microprogramming systems. The ACT823 offers noninverting outputs and is fully compatible with AMD's Am29823.

- TRI-STATE outputs for bus interfacing
- Inputs and outputs are on opposite sides
- ACT823 has TTL-compatible inputs
- Standard Microcircuit Drawing (SMD) 5962-9161001

Features

- Outputs source/sink 24 mA

Ordering Code

Order Number	Package Number	Package Description
54ACT823DMQB	J24A	24-Lead Ceramic Dual-in-line
54ACT823FMQB	W24C	24-Lead Cerpack
54ACT823LMQB	E28A	28-Lead Ceramic Leadless Chip Carrier, Type C

Logic Symbols

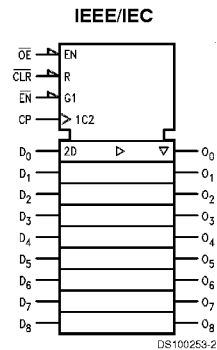
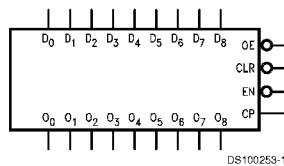

Pin Names	Description
D ₀ -D ₈	Data Inputs
O ₀ -O ₈	Data Outputs
\overline{OE}	Output Enable
\overline{CLR}	Clear
CP	Clock Input
\overline{EN}	Clock Enable

Connection Diagrams

Pin Assignment for DIP and Cerpack

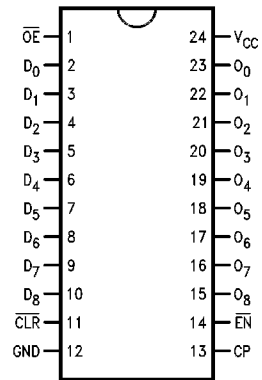

DS100253-3

Pin Assignment for LCC

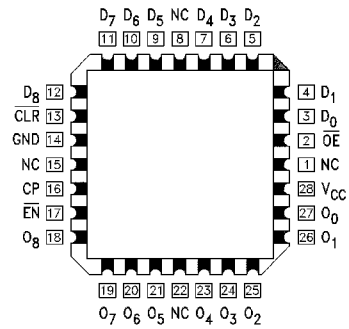

DS100253-4

Functional Description

The ACT823 consists of nine D-type edge-triggered flip-flops. These have TRI-STATE outputs for bus systems organized with inputs and outputs on opposite sides. The buffered clock (CP) and buffered Output Enable (\overline{OE}) are common to all flip-flops. The flip-flops will store the state of their individual D inputs that meet the setup and hold time requirements on the LOW-to-HIGH CP transition. With \overline{OE} LOW, the contents of the flip-flops are available at the outputs. When \overline{OE} is HIGH, the outputs go to the high impedance state. Operation of the \overline{OE} input does not affect the state of the flip-flops. In addition to the Clock and Output En-

able pins, there are Clear (\overline{CLR}) and Clock Enable (\overline{EN}) pins. These devices are ideal for parity bus interfacing in high performance systems.

When \overline{CLR} is LOW and \overline{OE} is LOW, the outputs are LOW. When \overline{CLR} is HIGH, data can be entered into the flip-flops. When \overline{EN} is LOW, data on the inputs is transferred to the outputs on the LOW-to-HIGH clock transition. When the \overline{EN} is HIGH, the outputs do not change state, regardless of the data or clock input transitions.

Function Table

Inputs					Internal	Output	Function
\overline{OE}	\overline{CLR}	\overline{EN}	CP	D	Q	O	
H	X	L	N	L	L	Z	High Z
H	X	L	N	H	H	Z	High Z
H	L	X	X	X	L	Z	Clear
L	L	X	X	X	L	L	Clear
H	H	H	X	X	NC	Z	Hold
L	H	H	X	X	NC	NC	Hold
H	H	L	N	L	L	Z	Load
H	H	L	N	H	H	Z	Load
L	H	L	N	L	L	L	Load
L	H	L	N	H	H	H	Load

H = HIGH Voltage Level
 L = LOW Voltage Level
 X = Immaterial
 Z = High Impedance
 N = LOW-to-HIGH Transition
 NC = No Change

Logic Diagram

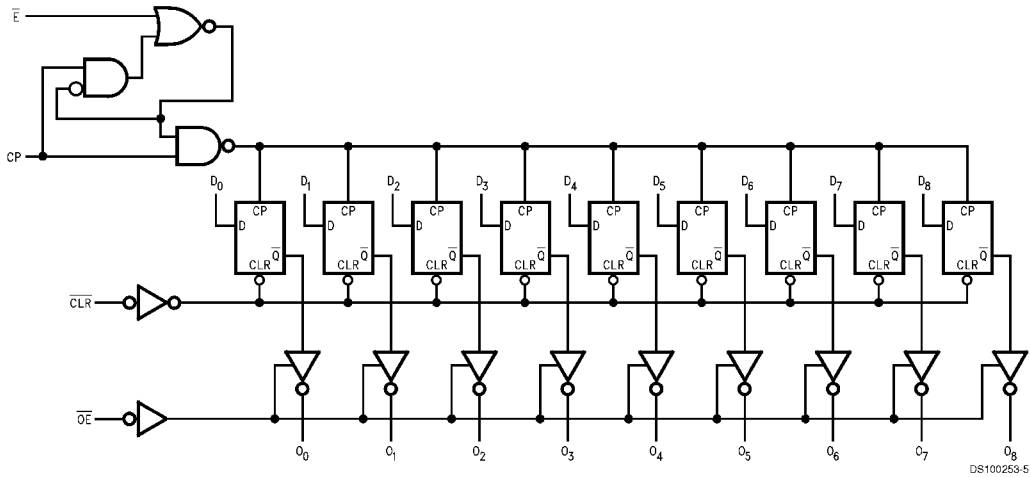

Please note that this diagram is provided only for the understanding of logic operations and should not be used to estimate propagation delays.

Absolute Maximum Ratings (Note 1)

If Military/Aerospace specified devices are required, please contact the National Semiconductor Sales Office/Distributors for availability and specifications.

Supply Voltage (V_{CC})	-0.5V to 7.0V
DC Input Diode Current (I_{IK})	
$V_I = -0.5V$	-20 mA
$V_I = V_{CC} + 0.5V$	+20 mA
DC Input Voltage (V_I)	-0.5V to $V_{CC} + 0.5V$
DC Output Diode Current (I_{OK})	
$V_O = -0.5V$	-20 mA
$V_O = V_{CC} + 0.5V$	+20 mA
DC Output Voltage (V_O)	-0.5V to $V_{CC} + 0.5V$
DC Output Source or Sink Current (I_O)	±50 mA
DC V_{CC} or Ground Current per Output Pin (I_{CC} or I_{GND})	±50 mA
Storage Temperature (T_{STG})	-65°C to +150°C

Junction Temperature (T_J)

CDIP

175°C

Recommended Operating Conditions

Supply Voltage (V_{CC})	ACT	4.5V to 5.5V
Input Voltage (V_I)		0V to V_{CC}
Output Voltage (V_O)		0V to V_{CC}
Operating Temperature (T_A)	54ACT	-55°C to +125°C
Minimum Input Edge Rate ($\Delta V/\Delta t$)	ACT Devices	
	V_{IN} from 0.8V to 2.0V	
	V_{CC} @ 4.5V, 5.5V	125 mV/ns

Note 1: Absolute maximum ratings are those values beyond which damage to the device may occur. The databook specifications should be met, without exception, to ensure that the system design is reliable over its power supply, temperature, and output/input loading variables. National does not recommend operation of FACT™ circuits outside databook specifications.

DC Electrical Characteristics

Symbol	Parameter	V_{CC} (V)	$T_A =$ -55°C to +125°C	Units	Conditions
V_{IH}	Minimum High Level Input Voltage	4.5	2.0	V	$V_{OUT} = 0.1V$ or $V_{CC} - 0.1V$
		5.5	2.0		
V_{IL}	Maximum Low Level Input Voltage	4.5	0.8	V	$V_{OUT} = 0.1V$ or $V_{CC} - 0.1V$
		4.5	0.8		
V_{OH}	Minimum High Level Output Voltage	4.5	3.7	V	$I_{OH} = -24$ mA
V_{OL}	Maximum Low Level Output Voltage	4.5	0.5	V	$I_{OL} = 24$ mA
I_{IN}	Maximum Input Leakage Current	5.5	±1.0	µA	$V_I = V_{CC}, GND$
I_{OZ}	Maximum TRI-STATE Current	5.5	±10.0	µA	$V_I = V_{IL}, V_{IH}$ $V_O = V_{CC}, GND$
I_{CCT}	Maximum I_{CC} /Input	5.5	1.6	mA	$V_I = V_{CC} - 2.1V$
I_{OLD}	(Note 3) Minimum Dynamic Output Current	5.5	50	mA	$V_{OLD} = 1.65V$ Max
		5.5	-50	mA	$V_{OHD} = 3.85V$ Min
I_{CC}	Maximum Quiescent Supply Current	5.5	160	µA	$V_{IN} = V_{CC}$ or GND

Note 2: All outputs loaded; thresholds on input associated with output under test.

Note 3: Maximum test duration 2.0 ms, one output loaded at a time.

AC Electrical Characteristics

Symbol	Parameter	V_{CC} (V) (Note 4)	$T_A = -55^\circ\text{C to } +125^\circ\text{C}$ $C_L = 50$ pF		Units
			Min	Max	
f_{max}	Maximum Clock Frequency	5.0	95		MHz
t_{PLH}	Propagation Delay CP to O_n	5.0	1.0	12.0	ns

AC Electrical Characteristics (Continued)

Symbol	Parameter	V _{CC} (V) (Note 4)	T _A = -55°C to +125°C C _L = 50 pF		Units
			Min	Max	
t _{PHL}	Propagation Delay CP to O _n	5.0	1.0	12.0	ns
t _{PHL}	Propagation Delay CLR to O _n	5.0	1.0	18.0	ns
t _{PZH}	Output Enable Time OE to O _n	5.0	1.0	11.5	ns
t _{PZL}	Output Enable Time OE to O _n	5.0	1.0	12.0	ns
t _{PHZ}	Output Disable Time OE to O _n	5.0	1.0	13.5	ns
t _{PLZ}	Output Disable Time OE to O _n	5.0	1.0	12.0	ns

Note 4: Voltage Range 5.0 is 5.0V ±0.5V

AC Operating Requirements

Symbol	Parameter	V _{CC} (V) (Note 5)	T _A = -55°C to +125°C C _L = 50 pF	Units
			Guaranteed Minimum	
t _s	Setup Time, HIGH or LOW D to CP	5.0	4.0	ns
t _h	Hold Time, HIGH or LOW D _n to CP	5.0	3.0	ns
t _s	Setup Time, HIGH or LOW EN to CP	5.0	4.0	ns
t _h	Hold Time, HIGH or LOW EN to CP	5.0	3.0	ns
t _w	CP Pulse Width HIGH or LOW	5.0	6.0	ns
t _w	CLR Pulse Width, LOW	5.0	7.5	ns
t _{rec}	CLR to CP Recovery Time	5.0	4.5	ns

Note 5: Voltage Range 5.0 is 5.0V ±0.5V

Capacitance

Symbol	Parameter	Max	Units	Conditions
C_{IN}	Input Capacitance	4.5	pF	$V_{CC} = OPEN$
C_{PD}	Power Dissipation Capacitance	4.4	pF	$V_{CC} = 5.0V$

Physical Dimensions inches (millimeters) unless otherwise noted

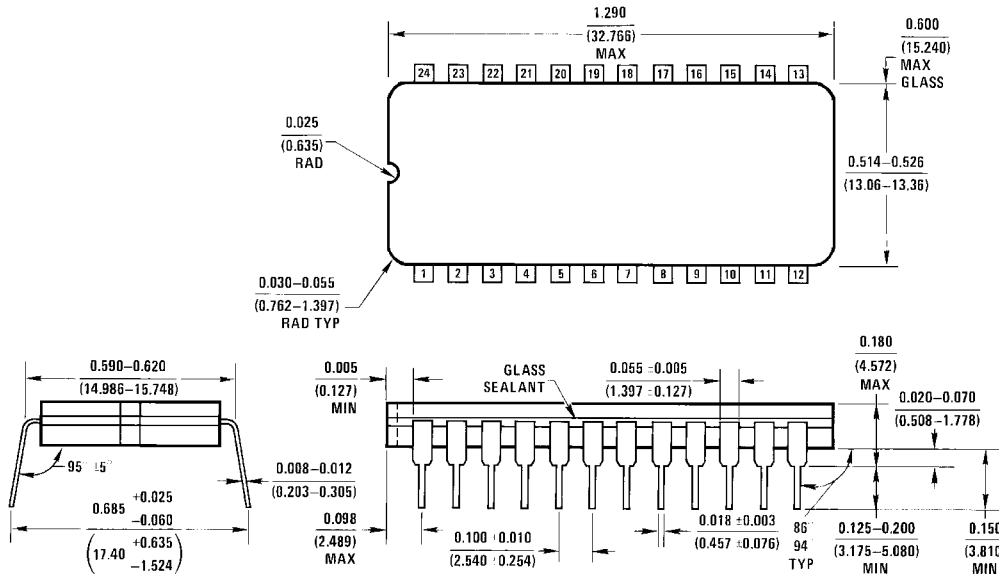

J24A (REV H)

**24 Lead Ceramic Dual-in-line
Package Number J24A**

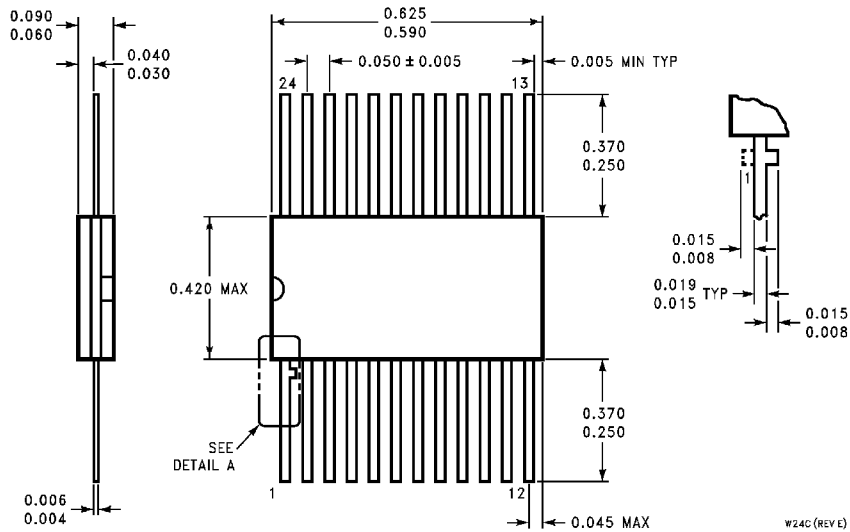

W24C (REV E)

**24 Lead Cerpack
Package Number W24C**

