

T-45-17

401



54F/74F401 CRC Generator/Checker

General Description

The 'F401 Cycle Redundancy Check (CRC) Generator/Checker provides an advanced tool for implementing the most widely used error detection scheme in serial digital data handling systems. A 3-bit control input selects one-of-eight generator polynomials. The list of polynomials includes CRC-16 and CRC-CCITT as well as their reciprocals (reverse polynomials). Automatic right justification is incorporated for polynomials of degree less than 16. Separate clear and preset inputs are provided for floppy disk and other applications. The Error output indicates whether or not a transmission error has occurred. Another control input inhibits feedback during check word transmission. The 'F401 is fully compatible with all TTL families.

Features

- Eight selectable polynomials
- Error indicator
- Separate preset and clear controls
- Automatic right justification
- Fully compatible with all TTL logic families
- 14-pin package
- 9401 equivalent
- Typical applications:
 - Floppy and other disk storage systems
 - Digital cassette and cartridge systems
 - Data communication systems

Ordering Code: See Section 5

Logic Symbol

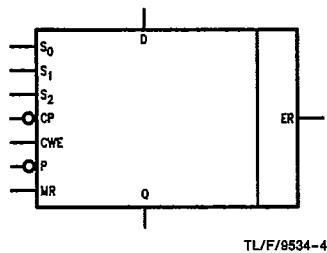

Connection Diagrams

Pin Assignment for DIP, SOIC and Flatpak

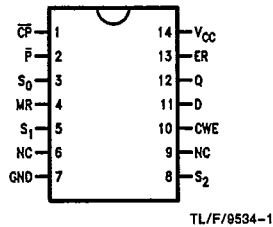

Pin Assignment for LCC and PCC

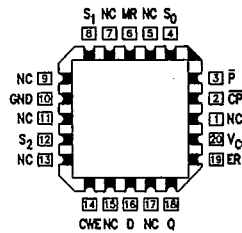

Unit Loading/Fan Out: See Section 2 for U.L. definitions

| Pin Names | Description | 54F/74F | |
|-----------------|--|---------------|--|
| | | U.L. HIGH/LOW | Input I_{IH}/I_{IL} Output I_{OH}/I_{OL} |
| S_0-S_2 | Polynomial Select Inputs | 1.0/1.0 | 20 μ A / -0.6 mA |
| D | Data Input | 1.0/1.0 | 20 μ A / -0.6 mA |
| \overline{CP} | Clock Input (Operates on HIGH-to-LOW Transition) | 1.0/1.0 | 20 μ A / -0.6 mA |
| CWE | Check Word Enable Input | 1.0/1.0 | 20 μ A / -0.6 mA |
| \overline{P} | Preset (Active LOW) Input | 1.0/1.0 | 20 μ A / -0.6 mA |
| MR | Master Reset (Active HIGH) Input | 1.0/1.0 | 20 μ A / -0.6 mA |
| Q | Data Output | 50/33.3 | -1 mA / 20 mA |
| ER | Error Output | 50/33.3 | -1 mA / 20 mA |

Functional Description

The 'F401 is a 16-bit programmable device which operates on serial data streams and provides a means of detecting transmission errors. Cyclic encoding and decoding schemes for error detection are based on polynomial manipulation in modulo arithmetic. For encoding, the data stream (message polynomial) is divided by a selected polynomial. This division results in a remainder which is appended to the message as check bits. For error checking, the bit stream containing both data and check bits is divided by the same selected polynomial. If there are no detectable errors, this division results in a zero remainder. Although it is possible to choose many generating polynomials of a given degree, standards exist that specify a small number of useful polynomials. The 'F401 implements the polynomials listed in Table I by applying the appropriate logic levels to the select pins S_0 , S_1 and S_2 .

The 'F401 consists of a 16-bit register, a Read Only Memory (ROM) and associated control circuitry as shown in the block diagram. The polynomial control code presented at inputs S_0 , S_1 and S_2 is decoded by the ROM, selecting the desired polynomial by establishing shift mode operation on the register with Exclusive OR gates at appropriate inputs. To generate the check bits, the data stream is entered via the Data inputs (D), using the HIGH-to-LOW transition of the

Clock input (\overline{CP}). This data is gated with the most significant output (Q) of the register, and controls the Exclusive OR gates (Figure 1). The Check Word Enable (CWE) must be held HIGH while the data is being entered. After the last data bit is entered, the CWE is brought LOW and the check bits are shifted out of the register and appended to the data bits using external gating (Figure 2).

To check an incoming message for errors, both the data and check bits are entered through the D input with the CWE input held HIGH. The 'F401 is not in the data path, but only monitors the message. The Error Output becomes valid after the last check bit has been entered into the 'F401 by a HIGH-to-LOW transition of \overline{CP} . If no detectable errors have occurred during the data transmission, the resultant internal register bits are all LOW and the Error Output (ER) is LOW. If a detectable error has occurred, ER is HIGH.

A HIGH on the Master Reset input (MR) asynchronously clears the register. A LOW on the Preset input (\overline{P}) asynchronously sets the entire register if the control code inputs specify a 16-bit polynomial; in the case of 12- or 8-bit check polynomials only the most significant 12 or 8 register bits are set and the remaining bits are cleared.

TABLE I

| Select Code | | | Polynomial | Remarks |
|-------------|-------|-------|--|-------------------|
| S_2 | S_1 | S_0 | | |
| L | L | L | $X^{16} + X^{15} + X^2 + 1$ | CRC-16 |
| L | L | H | $X^{16} + X^{14} + X + 1$ | CRC-16 REVERSE |
| L | H | L | $X^{16} + X^{15} + X^{13} + X^7 + X^4 + X^2 + X + 1$ | |
| L | H | H | $X^{12} + X^{11} + X^3 + X^2 + X + 1$ | CRC-12 |
| H | L | L | $X^8 + X^7 + X^5 + X^4 + X + 1$ | |
| H | L | H | $X^8 + 1$ | LRC-8 |
| H | H | L | $X^{16} + X^{12} + X^5 + 1$ | CRC-CCITT |
| H | H | H | $X^{16} + X^{11} + X^4 + 1$ | CRC-CCITT REVERSE |

Block Diagram

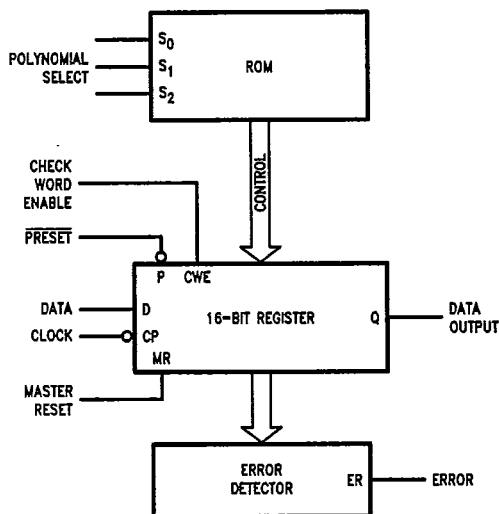

TL/F/9534-5

T-45-17

401

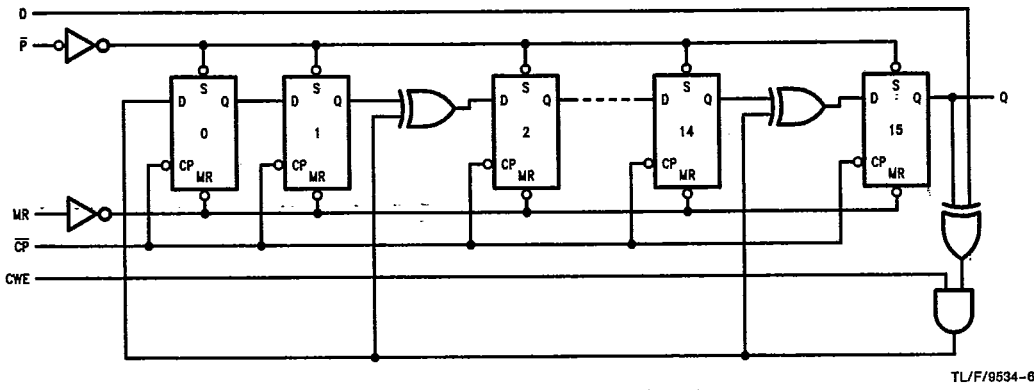

FIGURE 1. Equivalent Circuit for $X^{16} + X^{15} + X^2 + 1$

TL/F/9534-6

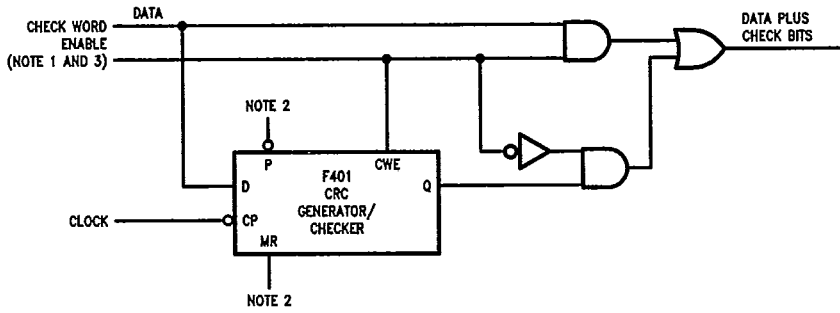

FIGURE 2. Check Word Generation

TL/F/9534-7

- Note 1:** Check word Enable is HIGH while data is being clocked, LOW while transmission of check bits.
- Note 2:** 'F401 must be reset or preset before each computation.
- Note 3:** CRC check bits are generated and appended to data bits.

T-45-17

401

Absolute Maximum Ratings (Note 1)

If Military/Aerospace specified devices are required, contact the National Semiconductor Sales Office/Distributors for availability and specifications.

| | |
|---|--------------------------|
| Storage Temperature | -65°C to +150°C |
| Ambient Temperature under Bias | -55°C to +125°C |
| Junction Temperature under Bias | -55°C to +175°C |
| V _{CC} Pin Potential to Ground Pin | -0.5V to +7.0V |
| Input Voltage (Note 2) | -0.5V to +7.0V |
| Input Current (Note 2) | -30 mA to +5.0 mA |
| Voltage Applied to Output in HIGH State (with V _{CC} = 0V) | |
| Standard Output | -0.5V to V _{CC} |
| TRI-STATE® Output | -0.5V to +5.5V |

Current Applied to Output in LOW State (Max) twice the rated I_{OL} (mA)

Note 1: Absolute maximum ratings are values beyond which the device may be damaged or have its useful life impaired. Functional operation under these conditions is not implied.

Note 2: Either voltage limit or current limit is sufficient to protect inputs.

Recommended Operating Conditions

| | |
|------------------------------|-----------------|
| Free Air Ambient Temperature | |
| Military | -55°C to +125°C |
| Commercial | 0°C to +70°C |
| Supply Voltage | |
| Military | +4.5V to +5.5V |
| Commercial | +4.5V to +5.5V |

DC Electrical Characteristics

| Symbol | Parameter | 54F/74F | | | Units | V _{CC} | Conditions |
|------------------|-----------------------------------|--|-------------------|------------|-------|-----------------|---|
| | | Min | Typ | Max | | | |
| V _{IH} | Input HIGH Voltage | 2.0 | | | V | | Recognized as a HIGH Signal |
| V _{IL} | Input LOW Voltage | | | 0.8 | V | | Recognized as a LOW Signal |
| V _{CD} | Input Clamp Diode Voltage | | | -1.2 | V | Min | I _{IN} = -18 mA |
| V _{OH} | Output HIGH Voltage | 54F 10% V _{CC} 74F 10% V _{CC} 74F 5% V _{CC} | 2.5 2.5 2.7 | | V | Min | I _{OH} = -1 mA I _{OH} = -1 mA I _{OH} = -1 mA |
| V _{OL} | Output LOW Voltage | 54F 10% V _{CC} 74F 10% V _{CC} | | 0.5 0.5 | V | Min | I _{OL} = 20 mA I _{OL} = 20 mA |
| I _{IH} | Input HIGH Current | | | 20 | μA | Max | V _{IN} = 2.7V |
| I _{BVI} | Input HIGH Current Breakdown Test | | | 100 | μA | Max | V _{IN} = 7.0V |
| I _{IL} | Input LOW Current | | | -0.6 | mA | Max | V _{IN} = 0.5V |
| I _{OS} | Output Short-Circuit Current | -60 | | -150 | mA | Max | V _{OUT} = 0V |
| I _{CEX} | Output HIGH Leakage Current | | | 250 | μA | Max | V _{OUT} = V _{CC} |
| I _{CC} | Power Supply Current | | 70 | 105 | mA | Max | V _O = HIGH |

T-45-17

401

AC Electrical Characteristics: See Section 2 for Waveforms and Load Configurations

| Symbol | Parameter | 74F | | | 54F | | 74F | | Units | Fig No |
|--------------------------------------|-------------------------------|---|-----|--------------|--|-----|--|----------------------|-------|--------|
| | | T _A = +25°C V _{CC} = +5.0V C _L = 50 pF | | | T _A , V _{CC} = Mil C _L = 50 pF | | T _A , V _{CC} = Com C _L = 50 pF | | | |
| | | Min | Typ | Max | Min | Max | Min | Max | | |
| f _{max} | Maximum Clock Frequency | 100 | | | | | | 85 | MHz | 2-1 |
| t _{PLH} t _{PHL} | Propagation Delay CP to Q | 4.5 | | 11.5 | | | | 4.5 13.5 4.0 11.0 | ns | 2-3 |
| t _{PHL} | Propagation Delay MR to Q | 3.0 | | 7.5 | | | | 3.0 8.0 | ns | 2-3 |
| t _{PLH} | Propagation Delay P to Q | 3.0 | | 8.5 | | | | 3.0 9.5 | ns | 2-3 |
| t _{PHL} | Propagation Delay MR to ER | 3.5 | | 11.0 | | | | 3.5 12.0 | ns | 2-3 |
| t _{PLH} | Propagation Delay P to ER | 3.0 | | 8.5 | | | | 3.0 10.0 | ns | 2-3 |
| t _{PLH} t _{PHL} | Propagation Delay CP to ER | 5.0 4.5 | | 13.0 11.5 | | | | 5.0 14.5 4.5 12.5 | ns | 2-3 |

AC Operating Requirements: See Section 2 for Waveforms

| Symbol | Parameter | 74F | | 54F | | 74F | | Units | Fig No |
|--|---|---|-----|--|-----|--|-----|-------|--------|
| | | T _A = +25°C V _{CC} = +5.0V | | T _A , V _{CC} = Mil | | T _A , V _{CC} = Com | | | |
| | | Min | Max | Min | Max | Min | Max | | |
| t _s (H) t _s (L) | Set-up Time, HIGH or LOW D to CP | 5.0 5.0 | | | | 5.5 5.5 | | ns | 2-6 |
| t _s (H) t _s (L) | Set-up Time, HIGH or LOW CWE to CP | 4.0 4.0 | | | | 4.5 4.5 | | | |
| t _h (H) t _h (L) | Hold Time, HIGH or LOW D and CWE to CP | 2.0 2.0 | | | | 2.0 2.0 | | | |
| t _w (L) | P Pulse Width, LOW | 7.0 | | | | 8.0 | | ns | 2-4 |
| t _w (H) t _w (L) | Clock Pulse Width, HIGH or LOW | 5.0 5.0 | | | | 6.0 6.0 | | ns | 2-4 |
| t _w (H) | MR Pulse Width, HIGH | 5.0 | | | | 5.5 | | ns | 2-4 |
| t _{rec} | Recovery Time MR to CP | 4.0 | | | | 4.5 | | ns | 2-6 |
| t _{rec} | Recovery Time P to CP | 2.0 | | | | 2.0 | | ns | 2-6 |

4