



# 54AC/74AC823 • 54ACT/74ACT823

## 9-Bit D Flip-Flop

### General Description

The 'ACT823 is a 9-bit buffered register. It features Clock Enable and Clear which are ideal for parity bus interfacing in high performance microprogramming systems. The 'ACT823 offers noninverting outputs and is fully compatible with AMD's Am29823.

### Features

- Outputs source/sink 24 mA
- TRI-STATE® outputs for bus interfacing
- Inputs and outputs are on opposite sides
- 'ACT823 has TTL-compatible inputs

The information for the 'AC823 is Advanced Information only.

**Ordering Code:** See Section 5

### Logic Symbols

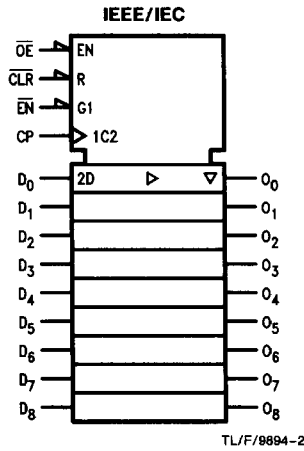
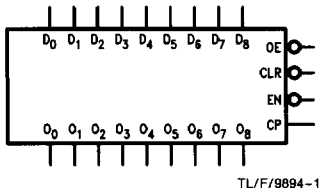

### Connection Diagrams

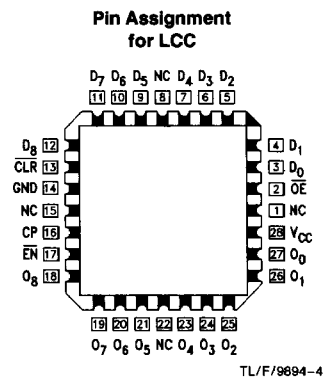
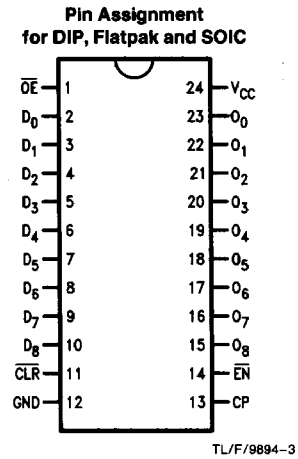

Pin Names	Description
D <sub>0</sub> -D <sub>8</sub>	Data Inputs
O <sub>0</sub> -O <sub>8</sub>	Data Outputs
OE	Output Enable
CLR	Clear
CP	Clock Input
EN	Clock Enable

## Functional Description

The 'ACT823 consists of nine D-type edge-triggered flip-flops. These have TRI-STATE outputs for bus systems organized with inputs and outputs on opposite sides. The buffered clock (CP) and buffered Output Enable ( $\overline{OE}$ ) are common to all flip-flops. The flip-flops will store the state of their individual D inputs that meet the setup and hold time requirements on the LOW-to-HIGH CP transition. With  $\overline{OE}$  LOW, the contents of the flip-flops are available at the outputs. When  $\overline{OE}$  is HIGH, the outputs go to the high impedance state. Operation of the  $\overline{OE}$  input does not affect

the state of the flip-flops. In addition to the Clock and Output Enable pins, there are Clear ( $\overline{CLR}$ ) and Clock Enable ( $\overline{EN}$ ) pins. These devices are ideal for parity bus interfacing in high performance systems.

When  $\overline{CLR}$  is LOW and  $\overline{OE}$  is LOW, the outputs are LOW. When  $\overline{CLR}$  is HIGH, data can be entered into the flip-flops. When  $\overline{EN}$  is LOW, data on the inputs is transferred to the outputs on the LOW-to-HIGH clock transition. When the  $\overline{EN}$  is HIGH, the outputs do not change state, regardless of the data or clock input transitions.

Function Table

Inputs					Internal	Output	Function
$\overline{OE}$	$\overline{CLR}$	$\overline{EN}$	CP	D	Q	O	
H	X	L	↗	L	L	Z	High Z
H	X	L	↗	H	H	Z	High Z
H	L	X	X	X	L	Z	Clear
L	L	X	X	X	L	L	Clear
H	H	H	X	X	NC	Z	Hold
L	H	H	X	X	NC	NC	Hold
H	H	L	↗	L	L	Z	Load
H	H	L	↗	H	H	Z	Load
L	H	L	↗	L	L	L	Load
L	H	L	↗	H	H	H	Load

H = HIGH Voltage Level  
 L = LOW Voltage Level  
 X = Immaterial  
 Z = High Impedance  
 ↗ = LOW-to-HIGH Transition  
 NC = No Change

## Logic Diagram

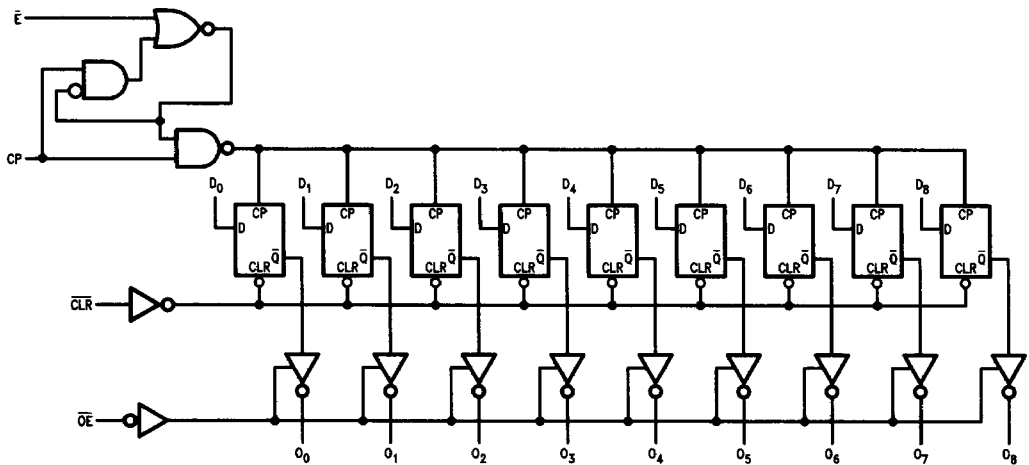

TL/F/9894-5

Please note that this diagram is provided only for the understanding of logic operations and should not be used to estimate propagation delays.

## Absolute Maximum Ratings (Note 1)

If Military/Aerospace specified devices are required, please contact the National Semiconductor Sales Office/Distributors for availability and specifications.

Supply Voltage ( $V_{CC}$ )	-0.5V to 7.0V
DC Input Diode Current ( $I_{IK}$ )	
$V_I = -0.5V$	-20 mA
$V_I = V_{CC} + 0.5V$	+20 mA
DC Input Voltage ( $V_I$ )	-0.5V to $V_{CC} + 0.5V$
DC Output Diode Current ( $I_{OK}$ )	
$V_O = -0.5V$	-20 mA
$V_O = V_{CC} + 0.5V$	+20 mA
DC Output Voltage ( $V_O$ )	-0.5V to $V_{CC} + 0.5V$
DC Output Source or Sink Current ( $I_O$ )	±50 mA
DC $V_{CC}$ or Ground Current per Output Pin ( $I_{CC}$ or $I_{GND}$ )	±50 mA
Storage Temperature ( $T_{STG}$ )	-65°C to +150°C

**Note 1:** Absolute maximum ratings are those values beyond which damage to the device may occur. The databook specifications should be met, without exception, to ensure that the system design is reliable over its power supply, temperature, and output/input loading variables. National does not recommend operation of FACT™ circuits outside databook specifications.

## Recommended Operating Conditions

Supply Voltage ( $V_{CC}$ )	
'AC	2.0V to 6.0V
'ACT	4.5V to 5.5V
Input Voltage ( $V_I$ )	0V to $V_{CC}$
Output Voltage ( $V_O$ )	0V to $V_{CC}$
Operating Temperature ( $T_A$ )	
74AC/ACT	-40°C to +85°C
54AC/ACT	-55°C to +125°C
Junction Temperature ( $T_J$ )	
CDIP	175°C
PDIP	140°C
Input Rise and Fall Time ( $t_r, t_f$ )	
(Note 2) (Typical)	
(Except Schmitt Inputs) 'AC Devices	
$V_{IN}$ from 30% to 70% of $V_{CC}$	
$V_{CC} @ 3.0V$	150 ns/V
$V_{CC} @ 4.5V$	40 ns/V
$V_{CC} @ 5.5V$	25 ns/V
Input Rise and Fall Time ( $t_r, t_f$ )	
(Note 2) (Typical)	
(Except Schmitt Inputs) 'ACT Devices	
$V_{IN}$ from 0.8V to 2.0V, $V_{meas}$ from 0.8V to 2.0V	
$V_{CC} @ 4.5V$	10 ns/V
$V_{CC} @ 5.5V$	8 ns/V

**Note 2:** See individual datasheets for those devices which differ from the typical input rise and fall times noted here.

## DC Electrical Characteristics

Symbol	Parameter	$V_{CC}$ (V)	74ACT		54ACT	74ACT		Units	Conditions
			$T_A = 25^\circ C$		$T_A =$ -55°C to +125°C	$T_A =$ -40°C to +85°C			
			Typ	Guaranteed Limits					
$V_{IH}$	Minimum High Level Input Voltage	4.5	1.5	2.0	2.0	2.0	2.0	V	$V_{OUT} = 0.1V$ or $V_{CC} - 0.1V$
		5.5	1.5	2.0	2.0	2.0	2.0		
$V_{IL}$	Maximum Low Level Input Voltage	4.5	1.5	0.8	0.8	0.8	0.8	V	$V_{OUT} = 0.1V$ or $V_{CC} - 0.1V$
		4.5	1.5	0.8	0.8	0.8	0.8		
$V_{OH}$	Minimum High Level	4.5	4.49	4.4	4.4	4.4	4.4	V	$I_{OUT} = -50 \mu A$
			5.49	5.4	5.4	5.4	5.4		
		4.5		3.86	3.70	3.76	3.76	V	* $V_{IN} = V_{IL}$ or $V_{IH}$ $I_{OH} = -24 mA$ -24 mA
$V_{OL}$	Maximum Low Level Output Voltage	4.5	0.001	0.1	0.1	0.1	0.1	V	$I_{OUT} = 50 \mu A$
		5.5	0.001	0.1	0.1	0.1	0.1		
		4.5		0.36	0.50	0.44	0.44	V	* $V_{IN} = V_{IL}$ or $V_{IH}$ $I_{OL} = 24 mA$ 24 mA
		5.5		0.36	0.50	0.50	0.44		
$I_{IN}$	Maximum Input Leakage Current	5.5		±0.1	±1.0	±1.0	±1.0	μA	$V_I = V_{CC}, GND$
$I_{OZ}$	Maximum TRI-STATE Current	5.5		±0.5	±10.0	±5.0	±5.0	μA	$V_I = V_{IL}, V_{IH}$ $V_O = V_{CC}, GND$
$I_{CCT}$	Maximum $I_{CC}/Input$	5.5	0.6		1.6	1.5	1.5	mA	$V_I = V_{CC} - 2.1V$
$I_{OLD}$	†Minimum Dynamic Output Current	5.5			50	75	75	mA	$V_{OLD} = 1.65V$ Max
$I_{OHD}$		5.5			-50	-75	-75	mA	$V_{OHD} = 3.85V$ Min
$I_{CC}$	Maximum Quiescent Supply Current (Note 1)	5.5		8.0	160	80	80	μA	$V_{IN} = V_{CC}$ or GND

\*All outputs loaded; thresholds on input associated with output under test.

†Maximum test duration 2.0 ms, one output loaded at a time.

**Note 1:**  $I_{CC}$  limit for 54ACT @ 25°C is identical to 74ACT @ 25°C.

## AC Electrical Characteristics: See Section 2 for Waveforms and Load Configurations

Symbol	Parameter	V <sub>CC</sub> * (V)	74ACT			54ACT		74ACT		Units	Fig. No.
			T <sub>A</sub> = +25°C C <sub>L</sub> = 50pF			T <sub>A</sub> = -55°C to +125°C C <sub>L</sub> = 50 pF		T <sub>A</sub> = -40°C to +85°C C <sub>L</sub> = 50 pF			
			Min	Typ	Max	Min	Max	Min	Max		
f <sub>max</sub>	Maximum Clock Frequency	5.0	120	158		95		109	MHz	2-3	
t <sub>PLH</sub>	Propagation Delay CP to O <sub>n</sub>	5.0	1.5	5.5	9.5	1.0	12.0	1.5	10.5	ns	2-6
t <sub>PHL</sub>	Propagation Delay CP to O <sub>n</sub>	5.0	2.0	5.5	9.5	1.0	12.0	1.5	10.5	ns	2-6
t <sub>PHL</sub>	Propagation Delay CLR to O <sub>n</sub>	5.0	2.5	8.0	13.5	1.0	18.0	2.0	15.5	ns	2-6
t <sub>PZH</sub>	Output Enable Time OE to O <sub>n</sub>	5.0	1.5	6.0	10.5	1.0	11.5	1.5	11.5	ns	2-7
t <sub>PZL</sub>	Output Enable Time OE to O <sub>n</sub>	5.0	2.0	6.5	11.0	1.0	12.0	1.5	12.0	ns	2-8
t <sub>PHZ</sub>	Output Disable Time OE to O <sub>n</sub>	5.0	1.5	6.5	11.0	1.0	13.5	1.5	12.0	ns	2-7
t <sub>PLZ</sub>	Output Disable Time OE to O <sub>n</sub>	5.0	1.5	6.0	10.5	1.0	12.0	1.5	11.5	ns	2-8

\*Voltage Range 5.0 is 5.0V ±0.5V

## AC Operating Requirements: See Section 2 for Waveforms

Symbol	Parameter	V <sub>CC</sub> * (V)	74ACT		54ACT		74ACT		Units	Fig. No.
			T <sub>A</sub> = +25°C C <sub>L</sub> = 50 pF		T <sub>A</sub> = -55°C to +125°C C <sub>L</sub> = 50 pF		T <sub>A</sub> = -40°C to +85°C C <sub>L</sub> = 50 pF			
			Typ	Guaranteed Minimum						
t <sub>s</sub>	Setup Time, HIGH or LOW D to CP	5.0	0.5	2.5	4.0	2.5	ns	2-9		
t <sub>h</sub>	Hold Time, HIGH or LOW D <sub>n</sub> to CP	5.0	0	2.5	3.0	2.5	ns	2-9		
t <sub>s</sub>	Setup Time, HIGH or LOW EN to CP	5.0	0	2.0	4.0	2.5	ns	2-9		
t <sub>h</sub>	Hold Time, HIGH or LOW EN to CP	5.0	0	1.0	3.0	1.0	ns	2-9		
t <sub>w</sub>	CP Pulse Width HIGH or LOW	5.0	2.5	4.5	6.0	5.5	ns	2-6		
t <sub>w</sub>	CLR Pulse Width, LOW	5.0	3.0	5.5	7.0	5.5	ns	2-6		
t <sub>rec</sub>	CLR to CP Recovery Time	5.0	1.5	3.5	4.5	4.0	ns	2-9		

\*Voltage Range 5.0 is 5.0V ±0.5V

## Capacitance

Symbol	Parameter	AC/ACT	Units	Conditions
		Typ		
C <sub>IN</sub>	Input Capacitance	4.5	pF	V <sub>CC</sub> = 5.0V
C <sub>PD</sub>	Power Dissipation Capacitance	44	pF	V <sub>CC</sub> = 5.0V