

T-46-07-12

843



# 74AC843 • 74ACT843

## 9-Bit Transparent Latch

### General Description

The 'AC/'ACT843 bus interface latch is designed to eliminate the extra packages required to buffer existing latches and provide extra data width for wider address/data paths. The 'AC/'ACT843 is functionally and pin compatible with AMD's Am29843.

### Features

- 'ACT843 has TTL-compatible inputs
- TRI-STATE® outputs for bus interfacing

**Ordering Code:** See Section 8

### Logic Symbols

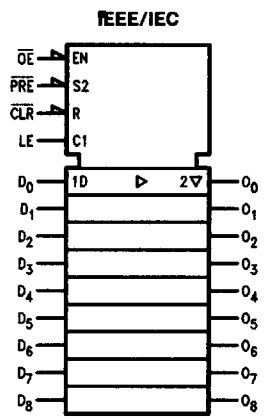
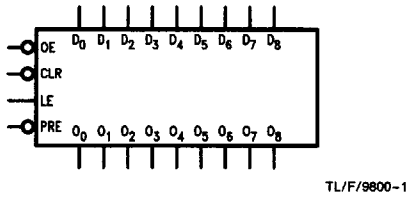

### Connection Diagram

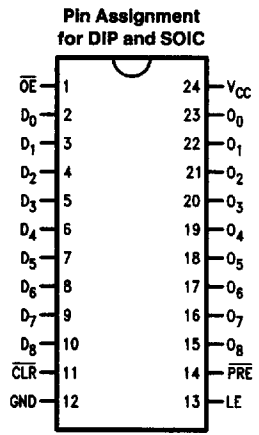

Pin Names	Description
D <sub>0</sub> -D <sub>8</sub>	Data Inputs
O <sub>0</sub> -O <sub>8</sub>	Data Outputs
OE	Output Enable
LE	Latch Enable
CLR	Clear
PRE	Preset

### Functional Description

The 'AC/ACT843 consists of nine D-type latches with TRI-STATE outputs. The flip-flops appear transparent to the data when Latch Enable (LE) is HIGH. This allows asynchronous operation, as the output transition follows the data in transition. On the LE HIGH-to-LOW transition, the data that meets the setup times is latched. Data appears on the bus when the Output Enable ( $\overline{OE}$ ) is LOW. When  $\overline{OE}$  is HIGH, the bus output is in the high impedance state. In

addition to the LE and  $\overline{OE}$  pins, the 'AC/ACT843 has a Clear ( $\overline{CLR}$ ) pin and a Preset ( $\overline{PRE}$ ) pin. These pins are ideal for parity bus interfacing in high performance systems. When  $\overline{CLR}$  is LOW, the outputs are LOW if  $\overline{OE}$  is LOW. When  $\overline{CLR}$  is HIGH, data can be entered into the latch. When  $\overline{PRE}$  is LOW, the outputs are HIGH if  $\overline{OE}$  is LOW. Preset overrides  $\overline{CLR}$ .

Function Tables

Inputs					Internal	Outputs	Function
$\overline{CLR}$	$\overline{PRE}$	$\overline{OE}$	LE	D	Q	O	
H	H	H	H	L	L	Z	High Z
H	H	H	H	H	H	Z	High Z
H	H	H	L	X	NC	Z	Latched
H	H	L	H	L	L	L	Transparent
H	H	L	H	H	H	H	Transparent
H	H	L	L	X	NC	NC	Latched
H	L	L	X	X	H	H	Preset
L	H	L	X	X	L	L	Clear
L	L	L	X	X	H	H	Preset
L	H	H	L	X	L	Z	Clear/High Z
H	L	H	L	X	H	Z	Preset/High Z

H = HIGH Voltage Level  
 L = LOW Voltage Level  
 X = Immaterial  
 Z = High Impedance  
 NC = No Change

### Logic Diagram

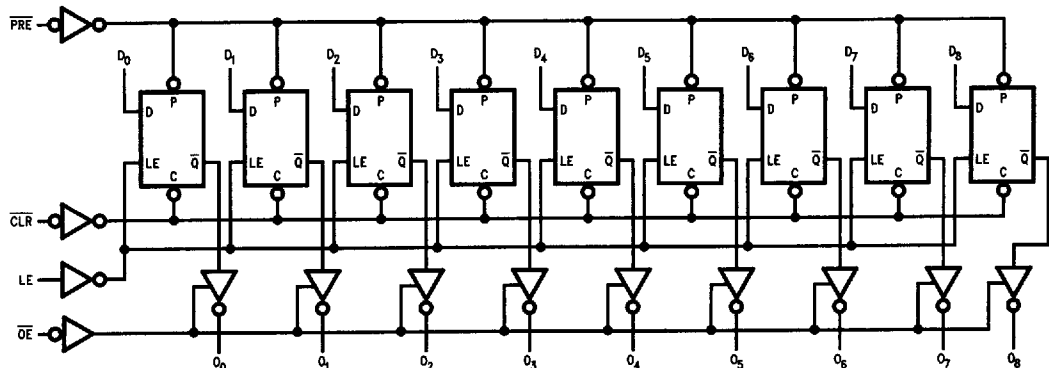

TL/F/8600-5

### Absolute Maximum Ratings (Note 1)

If Military/Aerospace specified devices are required, please contact the National Semiconductor Sales Office/Distributors for availability and specifications.

Supply Voltage (V <sub>CC</sub> )	-0.5V to +7.0V
DC Input Diode Current (I <sub>IK</sub> )	
V <sub>I</sub> = -0.5V	-20 mA
V <sub>I</sub> = V <sub>CC</sub> + 0.5V	+20 mA
DC Input Voltage (V <sub>I</sub> )	-0.5V to V <sub>CC</sub> + 0.5V
DC Output Diode Current (I <sub>OK</sub> )	
V <sub>O</sub> = -0.5V	-20 mA
V <sub>O</sub> = V <sub>CC</sub> + 0.5V	+20 mA
DC Output Voltage (V <sub>O</sub> )	-0.5V to V <sub>CC</sub> + 0.5V
DC Output Source or Sink Current (I <sub>O</sub> )	±50 mA
DC V <sub>CC</sub> or Ground Current per Output Pin (I <sub>CC</sub> or I <sub>GND</sub> )	±50 mA
Storage Temperature (T <sub>STG</sub> )	-65°C to +150°C
Junction Temperature (T <sub>J</sub> ) PDIP	140°C

### Recommended Operating Conditions

Supply Voltage (V <sub>CC</sub> )	'AC	2.0V to 6.0V
	'ACT	4.5V to 5.5V
Input Voltage (V <sub>I</sub> )		0V to V <sub>CC</sub>
Output Voltage (V <sub>O</sub> )		0V to V <sub>CC</sub>
Operating Temperature (T <sub>A</sub> )	74AC/ACT	-40°C to +85°C
Minimum Input Edge Rate (ΔV/Δt)	'AC Devices	
	V <sub>IN</sub> from 30% to 70% of V <sub>CC</sub>	
	V <sub>CC</sub> @ 3.3V, 4.5V, 5.5V	125 mV/ns
Minimum Input Edge Rate (ΔV/Δt)	'ACT Devices	
	V <sub>IN</sub> from 0.8V to 2.0V	
	V <sub>CC</sub> @ 4.5V, 5.5V	125 mV/ns

**Note 1:** Absolute maximum ratings are those values beyond which damage to the device may occur. The databook specifications should be met, without exception, to ensure that the system design is reliable over its power supply, temperature, and output/input loading variables. National does not recommend operation of FACT™ circuits outside databook specifications.

### DC Electrical Characteristics for 'AC Family Devices

Symbol	Parameter	V <sub>CC</sub> (V)	74AC		74AC		Units	Conditions
			T <sub>A</sub> = +25°C		T <sub>A</sub> = -40°C to +85°C			
			Typ	Guaranteed Limits				
V <sub>IH</sub>	Minimum High Level Input Voltage	3.0	1.5	2.1	2.1		V	V <sub>OUT</sub> = 0.1V or V <sub>CC</sub> - 0.1V
		4.5	2.25	3.15	3.15			
		5.5	2.75	3.85	3.85			
V <sub>IL</sub>	Maximum Low Level Input Voltage	3.0	1.5	0.9	0.9		V	V <sub>OUT</sub> = 0.1V or V <sub>CC</sub> - 0.1V
		4.5	2.25	1.35	1.35			
		5.5	2.75	1.65	1.65			
V <sub>OH</sub>	Minimum High Level Output Voltage	3.0	2.99	2.9	2.9		V	I <sub>OUT</sub> = -50 μA
		4.5	4.49	4.4	4.4			
		5.5	5.49	5.4	5.4			
		3.0		2.56	2.46		V	*V <sub>IN</sub> = V <sub>IL</sub> or V <sub>IH</sub> -12 mA I <sub>OH</sub> -24 mA -24 mA
		4.5		3.86	3.76			
		5.5		4.86	4.76			
V <sub>OL</sub>	Maximum Low Level Output Voltage	3.0	0.002	0.1	0.1		V	I <sub>OUT</sub> = 50 μA
		4.5	0.001	0.1	0.1			
		5.5	0.001	0.1	0.1			
		3.0		0.36	0.44		V	*V <sub>IN</sub> = V <sub>IL</sub> or V <sub>IH</sub> 12 mA I <sub>OL</sub> 24 mA 24 mA
		4.5		0.36	0.44			
		5.5		0.36	0.44			
I <sub>IN</sub>	Maximum Input Leakage Current	5.5		±0.1	±1.0		μA	V <sub>I</sub> = V <sub>CC</sub> , GND

\*All outputs loaded; thresholds on input associated with output under test.

843

**DC Electrical Characteristics for 'AC Family Devices** (Continued)

Symbol	Parameter	V <sub>CC</sub> (V)	74AC		Units	Conditions	
			T <sub>A</sub> = +25°C				T <sub>A</sub> = -40°C to +85°C
			Typ	Guaranteed Limits			
I <sub>OZ</sub>	Maximum TRI-STATE Leakage Current	5.5		±0.5	±5.0	μA	V <sub>I</sub> (OE) = V <sub>IL</sub> , V <sub>IH</sub> V <sub>I</sub> = V <sub>CC</sub> , GND V <sub>O</sub> = V <sub>CC</sub> , GND
I <sub>OLD</sub>	†Minimum Dynamic Output Current	5.5			75	mA	V <sub>OLD</sub> = 1.65V Max
I <sub>OHD</sub>		5.5			-75	mA	V <sub>OHD</sub> = 3.85V Min
I <sub>CC</sub>	Maximum Quiescent Supply Current	5.5		8.0	80.0	μA	V <sub>IN</sub> = V <sub>CC</sub> or GND

†Maximum test duration 2.0 ms, one output loaded at a time.  
 Note: I<sub>IN</sub> and I<sub>CC</sub> @ 3.0V are guaranteed to be less than or equal to the respective limit @ 5.5V V<sub>CC</sub>.

**DC Electrical Characteristics for 'ACT Family Devices**

Symbol	Parameter	V <sub>CC</sub> (V)	74ACT		74ACT		Units	Conditions
			T <sub>A</sub> = +25°C		T <sub>A</sub> = -40°C to +85°C			
			Typ	Guaranteed Limits				
V <sub>IH</sub>	Minimum High Level Input Voltage	4.5	1.5	2.0	2.0	V	V <sub>OUT</sub> = 0.1V or V <sub>CC</sub> - 0.1V	
		5.5	1.5	2.0	2.0			
V <sub>IL</sub>	Maximum Low Level Input Voltage	4.5	1.5	0.8	0.8	V	V <sub>OUT</sub> = 0.1V or V <sub>CC</sub> - 0.1V	
		5.5	1.5	0.8	0.8			
V <sub>OH</sub>	Minimum High Level Output Voltage	4.5	4.49	4.4	4.4	V	I <sub>OUT</sub> = -50 μA	
		5.5	5.49	5.4	5.4			
		4.5		3.86	3.76	V	*V <sub>IN</sub> = V <sub>IL</sub> or V <sub>IH</sub> -24 mA	
V <sub>OL</sub>	Maximum Low Level Output Voltage	4.5	0.001	0.1	0.1	V	I <sub>OUT</sub> = 50 μA	
		5.5	0.001	0.1	0.1			
		4.5		0.36	0.44	V	*V <sub>IN</sub> = V <sub>IL</sub> or V <sub>IH</sub> 24 mA	
I <sub>IN</sub>	Maximum Input Leakage Current	5.5		±0.1	±1.0	μA	V <sub>I</sub> = V <sub>CC</sub> , GND	
I <sub>OZ</sub>	Maximum TRI-STATE Leakage Current	5.5		±0.5	±5.0	μA	V <sub>I</sub> = V <sub>IL</sub> , V <sub>IH</sub> V <sub>O</sub> = V <sub>CC</sub> , GND	
I <sub>CC</sub> T	Maximum I <sub>CC</sub> /Input	5.5	0.6		1.5	mA	V <sub>I</sub> = V <sub>CC</sub> - 2.1V	
I <sub>OLD</sub>	†Minimum Dynamic Output Current	5.5			75	mA	V <sub>OLD</sub> = 1.65V Max	
I <sub>OHD</sub>		5.5			-75	mA	V <sub>OHD</sub> = 3.85V Min	
I <sub>CC</sub>	Maximum Quiescent Supply Current	5.5		8.0	80.0	μA	V <sub>IN</sub> = V <sub>CC</sub> or GND	

\*All outputs loaded; thresholds on input associated with output under test.  
 †Maximum test duration 2.0 ms, one output loaded at a time.

**AC Electrical Characteristics:** See Section 2 for Waveforms

Symbol	Parameter	V <sub>CC</sub> * (V)	74AC			74AC		Units	Fig. No.
			T <sub>A</sub> = +25°C C <sub>L</sub> = 50 pF			T <sub>A</sub> = -40°C to +85°C C <sub>L</sub> = 50 pF			
			Min	Typ	Max	Min	Max		
t <sub>PLH</sub>	Propagation Delay D <sub>n</sub> to O <sub>n</sub>	3.3	3.5	6.5	12.0	2.5	13.0	ns	2-3, 4
		5.0	2.0	4.5	8.5	1.5	9.0		
t <sub>PHL</sub>	Propagation Delay D <sub>n</sub> to O <sub>n</sub>	3.3	4.0	7.0	12.0	3.0	13.0	ns	2-3, 4
		5.0	2.5	5.0	8.5	1.5	9.0		
t <sub>PLH</sub>	Propagation Delay LE to O <sub>n</sub>	3.3	3.5	6.5	12.0	13.0	2.5	ns	2-3, 4
		5.0	2.0	4.5	8.5	1.5	9.0		
t <sub>PHL</sub>	Propagation Delay LE to O <sub>n</sub>	3.3	4.0	7.0	12.0	3.0	13.0	ns	2-3, 4
		5.0	2.5	5.0	8.5	1.5	9.0		
t <sub>PLH</sub>	Propagation Delay PRE to O <sub>n</sub>	3.3	5.5	8.5	19.0	4.5	21.5	ns	2-3, 4
		5.0	3.5	6.0	13.0	2.5	14.5		
t <sub>PHL</sub>	Propagation Delay CLR to O <sub>n</sub>	3.3	7.5	11.0	21.5	6.0	24.0	ns	2-3, 4
		5.0	5.0	7.5	15.0	4.0	17.0		
t <sub>PZH</sub>	Output Enable Time OE to O <sub>n</sub>	3.3	3.5	6.0	11.0	3.0	12.0	ns	2-5, 6
		5.0	2.0	4.5	8.0	1.5	9.0		
t <sub>PZL</sub>	Output Enable Time OE to O <sub>n</sub>	3.3	4.0	6.5	11.0	2.5	12.0	ns	2-5, 6
		5.0	2.0	5.0	8.0	1.5	9.0		
t <sub>PHZ</sub>	Output Disable Time OE to O <sub>n</sub>	3.3	4.0	6.5	10.5	3.5	11.0	ns	2-5, 6
		5.0	3.0	5.0	8.0	2.5	8.5		
t <sub>PLZ</sub>	Output Disable Time OE to O <sub>n</sub>	3.3	3.0	6.0	10.5	2.5	11.0	ns	2-5, 6
		5.0	2.0	4.5	8.0	1.5	8.5		
t <sub>PHL</sub>	Propagation Delay PRE to O <sub>n</sub>	3.3	4.5	7.0	12.5	3.5	13.5	ns	2-3, 4
		5.0	3.0	5.0	9.0	2.0	9.5		
t <sub>PLH</sub>	Propagation Delay CLR to O <sub>n</sub>	3.3	4.5	7.0	12.5	3.5	13.5	ns	2-3, 4
		5.0	3.0	5.0	9.0	2.0	9.5		

\*Voltage Range 3.3 is 3.3V ± 0.3V

\*Voltage Range 5.0 is 5.0V ± 0.5V

843

**AC Operating Requirements:** See Section 2 for Waveforms

Symbol	Parameter	V <sub>CC</sub> * (V)	74AC		74AC		Units	Fig. No.
			T <sub>A</sub> = +25°C C <sub>L</sub> = 50 pF		T <sub>A</sub> = -40°C to +85°C C <sub>L</sub> = 50 pF			
			Typ	Guaranteed Minimum				
t <sub>s</sub>	Setup Time, HIGH or LOW D <sub>n</sub> to LE	3.3	0	3.0	3.5	ns	2-7	
		5.0	-0.5	1.5	2.0			
t <sub>h</sub>	Hold Time, HIGH or LOW D <sub>n</sub> to LE	3.3		2.0	2.0	ns	2-7	
		5.0	-0.5	2.5	2.5			
t <sub>w</sub>	LE Pulse Width, HIGH	3.3	1.5	3.0	3.0	ns	2-4	
		5.0	1.5	3.0	3.0			
t <sub>w</sub>	PRE Pulse Width, LOW	3.3	5.0	12.0	14.5	ns	2-4	
		5.0	3.0	8.5	10.0			
t <sub>w</sub>	CLR Pulse Width, LOW	3.3	5.5	14.0	16.5	ns	2-4	
		5.0	4.0	10.0	12.0			
t <sub>rec</sub>	PRE Recovery Time	3.3	1.0	3.0	3.0	ns	2-4, 7	
		5.0	0	1.5	1.5			
t <sub>rec</sub>	CLR Recovery Time	3.3	0	1.5	1.5	ns	2-4, 7	
		5.0	-0.5	0.5	0.5			

\*Voltage Range 3.3 is 3.3V ±0.3V

\*Voltage Range 5.0 is 5.0V ±0.5V

**AC Electrical Characteristics:** See Section 2 for Waveforms

Symbol	Parameter	V <sub>CC</sub> * (V)	74ACT			74ACT		Units	Fig. No.
			T <sub>A</sub> = +25°C C <sub>L</sub> = 50 pF			T <sub>A</sub> = -40°C to +85°C C <sub>L</sub> = 50 pF			
			Min	Typ	Max	Min	Max		
t <sub>PLH</sub>	Propagation Delay D <sub>n</sub> to O <sub>n</sub>	5.0	2.5	5.5	9.5	2.0	10.0	ns	2-3, 4
t <sub>PHL</sub>	Propagation Delay D <sub>n</sub> to O <sub>n</sub>	5.0	2.5	5.5	9.5	2.0	10.0	ns	2-3, 4
t <sub>PLH</sub>	Propagation Delay LE to O <sub>n</sub>	5.0	2.5	5.5	9.0	2.0	10.0	ns	2-3, 4
t <sub>PHL</sub>	Propagation Delay LE to O <sub>n</sub>	5.0	2.5	5.5	9.0	2.0	10.0	ns	2-3, 4
t <sub>PLH</sub>	Propagation Delay PRE to O <sub>n</sub>	5.0	2.5	6.5	14.0	2.0	16.0	ns	2-3, 4
t <sub>PHL</sub>	Propagation Delay CLR to O <sub>n</sub>	5.0	2.5	7.5	15.5	2.0	17.5	ns	2-3, 4
t <sub>PZH</sub>	Output Enable Time OE to O <sub>n</sub>	5.0	2.5	5.5	9.5	2.0	10.5	ns	2-5, 6
t <sub>PZL</sub>	Output Enable Time OE to O <sub>n</sub>	5.0	2.5	5.5	9.5	2.0	10.5	ns	2-5, 6
t <sub>PHZ</sub>	Output Disable Time OE to O <sub>n</sub>	5.0	2.5	6.0	10.5	2.0	11.0	ns	2-5, 6
t <sub>PLZ</sub>	Output Disable Time OE to O <sub>n</sub>	5.0	2.5	6.0	10.5	2.0	11.0	ns	2-5, 6
t <sub>PHL</sub>	Propagation Delay PRE to O <sub>n</sub>	5.0	2.5	6.0	10.5	2.0	11.0	ns	2-3, 4
t <sub>PLH</sub>	Propagation Delay CLR to O <sub>n</sub>	5.0	2.5	5.5	9.5	2.0	10.5	ns	2-3, 4

\*Voltage Range 5.0 is 5.0V ±0.5V

**AC Operating Requirements:** See Section 2 for Waveforms

Symbol	Parameter	V <sub>CC</sub> * (V)	74AC		74AC		Units	Fig. No.
			T <sub>A</sub> = +25°C C <sub>L</sub> = 50 pF		T <sub>A</sub> = -40°C to +85°C C <sub>L</sub> = 50 pF			
			Typ	Guaranteed Minimum				
t <sub>s</sub>	Setup Time, HIGH or LOW D <sub>n</sub> to LE	5.0	-0.5	0.5	1.0	ns	2-7	
t <sub>h</sub>	Hold Time, HIGH or LOW D <sub>n</sub> to LE	5.0	0.5	2.0	2.0	ns	2-7	
t <sub>w</sub>	LE Pulse Width, HIGH	5.0	2.0	3.5	3.5	ns	2-4	
t <sub>w</sub>	PRE Pulse Width, LOW	5.0	5.0	8.5	10.0	ns	2-4	
t <sub>w</sub>	CLR Pulse Width, LOW	5.0	5.5	9.5	11.0	ns	2-4	
t <sub>rec</sub>	PRE Recovery Time	5.0	0.5	2.0	2.0	ns	2-4, 7	
t <sub>rec</sub>	CLR Recovery Time	5.0	-0.5	1.0	1.0	ns	2-4, 7	

\*Voltage Range 5.0 is 5.0V ±0.5V

843

**Capacitance**

Symbol	Parameter	Typ	Units	Conditions
C <sub>IN</sub>	Input Capacitance	4.5	pF	V <sub>CC</sub> = OPEN
C <sub>PD</sub>	Power Dissipation Capacitance	44	pF	V <sub>CC</sub> = 5.0V