



54ACQ/74ACQ544 • 54ACTQ/74ACTQ544

Quiet Series Octal Registered Transceiver with TRI-STATE® Outputs

General Description

The ACQ/ACTQ544 is an inverting octal transceiver containing two sets of D-type registers for temporary storage of data flowing in either direction. Separate Latch Enable and Output Enable inputs are provided for each register to permit independent input and output control in either direction of data flow. The '544 inverts data in both directions.

The ACQ/ACTQ utilizes NSC Quiet Series technology to guarantee quiet output switching and improved dynamic threshold performance. FACT Quiet Series™ features GTO™ output control and undershoot corrector in addition to a split ground bus for superior performance.

Features

- Guaranteed simultaneous switching noise level and dynamic threshold performance
- Guaranteed pin-to-pin skew AC performance
- 8-bit inverting octal latched transceiver
- Separate controls for data flow in each direction
- Back-to-back registers for storage
- Outputs source/sink 24 mA
- 4 kV minimum ESD immunity
- 300 mil slim PDIP/SOIC

Logic Symbols

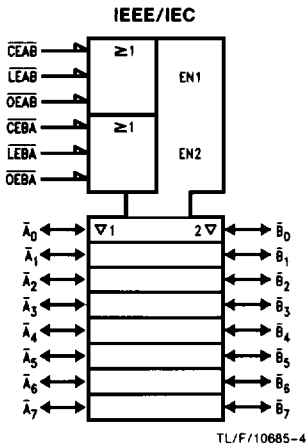
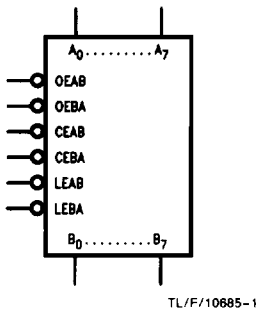

Connection Diagrams

