

# LQH32PN\_N0 Series 1210/3225 (inch/mm)

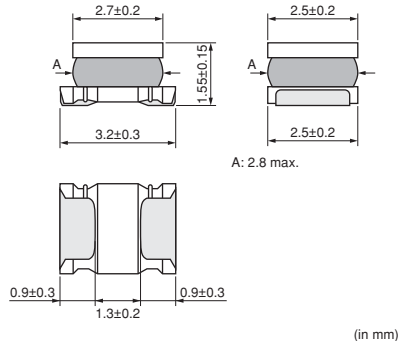

## ■ Dimensions



## ■ Packaging

Code	Packaging	Minimum Quantity
L	ø180mm Embossed Taping	2000
K	ø330mm Embossed Taping	7500

## ■ Rated Value (□: packaging code)

Part Number	Inductance	Inductance Test Frequency	Rated Current (Based on Inductance Change)	Rated Current (Based on Temperature Rise)	DC Resistance	Self-Resonance Frequency (min.)
LQH32PNR47NN0□	0.47μH ±30%	1MHz	3400mA	2550mA	0.03Ω ±20%	100MHz
LQH32PN1R0NN0□	1.0μH ±30%	1MHz	2300mA	2050mA	0.045Ω ±20%	100MHz
LQH32PN1R5NN0□	1.5μH ±30%	1MHz	1750mA	1750mA	0.057Ω ±20%	70MHz
LQH32PN2R2NN0□	2.2μH ±30%	1MHz	1550mA	1600mA	0.076Ω ±20%	70MHz
LQH32PN3R3NN0□	3.3μH ±30%	1MHz	1250mA	1200mA	0.12Ω ±20%	50MHz
LQH32PN4R7NN0□	4.7μH ±30%	1MHz	1000mA	1000mA	0.18Ω ±20%	40MHz
LQH32PN6R8NN0□	6.8μH ±30%	1MHz	850mA	850mA	0.24Ω ±20%	40MHz
LQH32PN100MN0□	10μH ±20%	1MHz	750mA	700mA	0.38Ω ±20%	30MHz
LQH32PN150MN0□	15μH ±20%	1MHz	600mA	520mA	0.57Ω ±20%	20MHz
LQH32PN220MN0□	22μH ±20%	1MHz	500mA	450mA	0.81Ω ±20%	20MHz
LQH32PN330MN0□	33μH ±20%	1MHz	380mA	390mA	1.15Ω ±20%	13MHz
LQH32PN470MN0□	47μH ±20%	1MHz	330mA	310mA	1.78Ω ±20%	11MHz
LQH32PN680MN0□	68μH ±20%	1MHz	280mA	275mA	2.28Ω ±20%	11MHz
LQH32PN101MN0□	100μH ±20%	1MHz	180mA	250mA	2.70Ω ±20%	8MHz
LQH32PN121MN0□	120μH ±20%	1MHz	170mA	200mA	4.38Ω ±20%	8MHz

Class of Magnetic Shield: Magnetic shield of magnetic powder in resin  
 Operating Temperature Range (Self-temperature rise is included): -40~125°C  
 Operating Temperature Range (Self-temperature rise is not included): -40~85°C  
 For reflow soldering only.

## ■ Notice (Rating)

When applied rated current to the products, inductance will be within ±30% of nominal inductance value.  
 When applied rated current to the products, temperature rise caused by self-generated heat shall be limited to 40°C max.  
 Keep the temperature (ambient temperature plus self-generation of heat) under 125°C.

Continued on the following page.

● This data sheet is applied for INDUCTORS (COILS) used for General Electronics equipment for your design.

## ⚠ Note:

- This datasheet is downloaded from the website of Murata Manufacturing co., ltd. Therefore, it's specifications are subject to change or our products in it may be discontinued without advance notice. Please check with our sales representatives or product engineers before ordering.
- This datasheet has only typical specifications because there is no space for detailed specifications. Therefore, please approve our product specifications or transact the approval sheet for product specifications before ordering.

Continued from the preceding page.

### Inductance-Frequency Characteristics (Typ.)

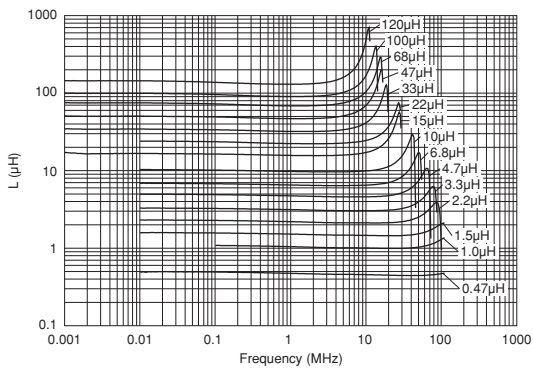

### Inductance-Current Characteristics (Typ.)

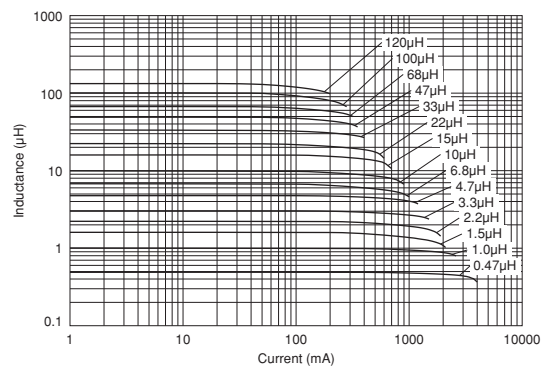

### Temperature Rise Characteristics (Typ.)

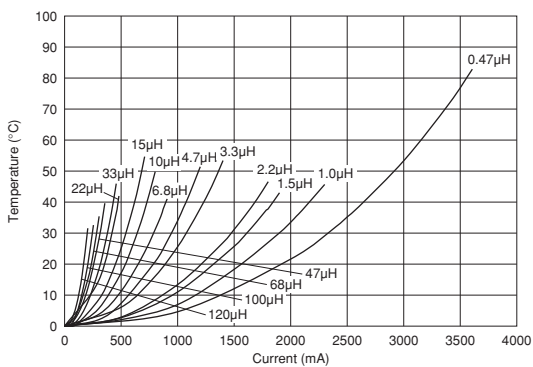

### Caution/Notice

#### Caution (Rating)

Do not use products beyond the rated current as this may create excessive heat.

#### Notice

Solderability of Tin plating termination chip might be deteriorated when low temperature soldering profile where peak solder temperature is below the Tin melting point is used. Please confirm the solderability of Tin plating termination chip before use.

This data sheet is applied for INDUCTORS (COILS) used for General Electronics equipment for your design.

#### Note:

- This datasheet is downloaded from the website of Murata Manufacturing co., ltd. Therefore, it's specifications are subject to change or our products in it may be discontinued without advance notice. Please check with our sales representatives or product engineers before ordering.
- This datasheet has only typical specifications because there is no space for detailed specifications. Therefore, please approve our product specifications or transact the approval sheet for product specifications before ordering.