



The Future of Analog IC Technology®

# MPQ2013

40V, 150mA, Low Quiescent Current  
Linear Regulator  
AEC-Q100 Qualified

## DESCRIPTION

The MPQ2013 is a low power linear regulator that supplies power to systems with high voltage batteries. It includes a wide 2.5V to 40V input range, low dropout voltage and low quiescent supply current. The low quiescent current and low dropout voltage allow operations at extremely low power levels. Therefore, the MPQ2013 are ideal for the low power microcontrollers and the battery-powered equipments.

The MPQ2013 provides wide variety of fixed output voltage options (if request): 1.8V, 1.9V, 2.3V, 2.5V, 3.0V, 3.3V, 3.45V, 5.0V; and also provides the output adjustable option (from 1.215V to 15V).

The regulator output current is internally limited and the device is protected against over-load and over-temperature conditions.

The MPQ2013 also includes thermal shutdown and current limiting fault protection, and is available in QFN6 (2x2mm), QFN8 (3x3mm) and TSOT23-5 packages.

## FEATURES

- 2.5V to 40V Input Range
- 3.2µA Quiescent Supply Current
- Stable With low-value output ceramic capacitor (> 0.47 µF)
- 150mA specified current
- 620mV Dropout at 150mA Load
- Available in Fixed and Adjustable output (1.215 V to 15 V) versions
- Output ±2% Accuracy
- Specified current limit
- Thermal Shutdown
- -40°C to +125°C Specified Junction Temperature Range
- Available in TSOT23-5, QFN6 (2x2mm), or QFN8 (3x3mm) Packages
- Available in AEC-Q100 Grade 1

## APPLICATIONS

- Industrial/Automotive Applications
- Portable/Battery-Powered Equipment
- Ultra low power Microcontrollers
- Cellular Handsets
- Medical Imaging

All MPS parts are lead-free and adhere to the RoHS directive. For MPS green status, please visit MPS website under Products, Quality Assurance page.

"MPS" and "The Future of Analog IC Technology" are registered trademarks of Monolithic Power Systems, Inc.

## TYPICAL APPLICATION

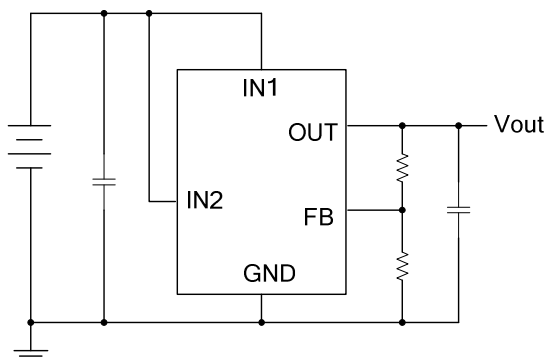

Output Adjustable Version

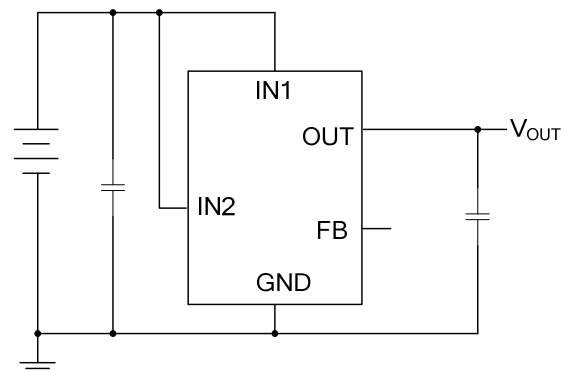

Output Fixed Version

## ORDERING INFORMATION

Part Number*	Package	Top Marking
MPQ2013GQ	QFN-8 (3mmx3mm)	AFF
MPQ2013GG	QFN-6 (2mmx2mm)	AX
MPQ2013GJ**	TSOT23-5	AFF
MPQ2013GQ-33**	QFN-8 (3mmx3mm)	AGG
MPQ2013GQ-AEC1	QFN-8 (3mmx3mm)	AFF
MPQ2013GJ-AEC1**	TSOT23-5	AFF
MPQ2013GQ-33-AEC1**	QFN-8 (3mmx3mm)	AGG

\* For Tape & Reel, add suffix -Z (e.g. MPQ2013GQ-Z)

\*\* Pre-release

## PACKAGE REFERENCE

	TOP VIEW	TOP VIEW
<b>TSOT23-5</b>	<b>QFN-6(2mmx2mm)</b>	<b>QFN-8(3mmx3mm)</b>

### ABSOLUTE MAXIMUM RATINGS <sup>(1)</sup>

IN1, IN2 .....	-0.3V to +42V
OUT .....	-0.3V to +17V
FB .....	-0.3V to +6V
Lead Temperature .....	260°C
Storage Temperature.....	-65°C to +150°C
Continuous Power Dissipation ( $T_A = +25^\circ\text{C}$ ) <sup>(2)</sup>	
QFN-8(3mmx3mm).....	2.08W
QFN-6(2mmx2mm).....	1.25W
TSOT23-5.....	0.45W

### ESD SUSCEPTIBILITY <sup>(3)</sup>

HBM (Human Body Mode) .....	2kV
MM (Machine Mode) .....	200V

### Recommended Operating Conditions <sup>(4)</sup>

Supply Voltage $V_{IN}$ .....	2.5V to 40V
Output Voltage $V_{OUT}$ .....	1.215V to 15V
Operating Junction Temp. ( $T_J$ ). .....	-40°C to +125°C

Thermal Resistance <sup>(5)</sup>	$\theta_{JA}$	$\theta_{JC}$
TSOT23-5 .....	220 .....	110 .....
QFN-6 (2mm x2mm) .....	80 .....	16 .....
QFN-8 (3mm x3mm) .....	48 .....	11 .....

#### Notes:

- Exceeding these ratings may damage the device.
- The maximum allowable power dissipation is a function of the maximum junction temperature  $T_J$  (MAX), the junction-to-ambient thermal resistance  $\theta_{JA}$ , and the ambient temperature  $T_A$ . The maximum allowable continuous power dissipation at any ambient temperature is calculated by  $P_D$  (MAX) =  $(T_J$  (MAX) -  $T_A$ ) /  $\theta_{JA}$ . Exceeding the maximum allowable power dissipation will cause excessive die temperature, and the regulator will go into thermal shutdown. Internal thermal shutdown circuitry protects the device from permanent damage.
- Devices are ESD sensitive. Handling precaution recommended.
- The device is not guaranteed to function outside of its operating conditions.
- Measured on JESD51-7, 4-layer PCB.

## ELECTRICAL CHARACTERISTICS

Over operating junction temperature range ( $T_J = -40^{\circ}\text{C}$  to  $+125^{\circ}\text{C}$ ),  $V_{\text{OUT(NOM)}} = 5\text{V}$  ( $V_{\text{IN}} \geq 6\text{V}$ ) or FB ( $V_{\text{IN}} < 6\text{V}$ ) for MPQ2013,  $V_{\text{OUT(NOM)}} = 3.3\text{V}$  ( $V_{\text{IN}} \geq 4.3\text{V}$ ) or FB ( $V_{\text{IN}} < 4.3\text{V}$ ) for MPQ2013-33,  $I_{\text{OUT}} = 1\text{mA}$ ,  $C_{\text{OUT}} = 1\mu\text{F}$ , unless otherwise noted. Typical values are at  $T_J = +25^{\circ}\text{C}$ .

Parameter	Symbol	Condition	Min	Typ	Max	Units	
Input Voltage	$V_{\text{IN}}$		2.5		40	V	
Output Voltage range	$V_{\text{OUT}}$		1.215		15	V	
GND Pin Current	$I_{\text{GND}}$	MPQ2013GQ, MPQ2013GG	$0 < I_{\text{OUT}} < 1\text{mA}$ , $V_{\text{IN}} = 2.5\text{V}$ to $40\text{V}$		3.2	9	$\mu\text{A}$
			$1\text{mA} < I_{\text{OUT}} < 30\text{mA}$ , $V_{\text{IN}} = 2.5\text{V}$ to $15\text{V}$		14	22	
			$30\text{mA} < I_{\text{OUT}} < 150\text{mA}$ , $V_{\text{IN}} = 3\text{V}$ to $6\text{V}$		35	50	
		MPQ2013GQ-33	$0 < I_{\text{OUT}} < 1\text{mA}$ , $V_{\text{IN}} = 4.3\text{V}$ to $40\text{V}$		4.4	10	
			$1\text{mA} < I_{\text{OUT}} < 30\text{mA}$ , $V_{\text{IN}} = 4.3\text{V}$ to $15\text{V}$		15	25	
			$30\text{mA} < I_{\text{OUT}} < 150\text{mA}$ , $V_{\text{IN}} = 4.3\text{V}$		35	50	
Load Current Limit	$I_{\text{LIMIT}}$	$V_{\text{OUT}} = 0\text{V}$ , $V_{\text{IN}} = 6\text{V}$ to $15\text{V}$	160	270	400	mA	
Output Voltage Accuracy		MPQ2013-33, $V_{\text{IN}} = 4.3\text{V}$ , $I_{\text{O}} = 0$	3.234	3.3	3.366	V	
FB Voltage	$V_{\text{FB}}$	FB = OUT, $V_{\text{IN}} = 5\text{V}$	1.191	1.215	1.239	V	
Dropout Voltage $V_{\text{IN}} = V_{\text{OUT(NOM)}} - 0.1\text{V}$	$V_{\text{DROPOUT}}$	MPQ2013GQ, MPQ2013GG, $I_{\text{LOAD}} = 150\text{mA}$ , $V_{\text{OUT(NOM)}} = 5\text{V}$		620	900	mV	
		MPQ2013GQ-33, $I_{\text{LOAD}} = 150\text{mA}$		740	1100		
FB Pin Input Current	$I_{\text{FB}}$	MPQ2013, $V_{\text{FB}} = 1.3\text{V}$ , $V_{\text{IN}} = 6\text{V}$ , OUT floating	-50	+4	+50	nA	
		MPQ2013-33, $V_{\text{FB}} = 1.3\text{V}$ , $V_{\text{IN}} = 6\text{V}$ , OUT floating	0.88	1.3	1.72	$\mu\text{A}$	
Line Regulation <sup>(6)</sup>		$V_{\text{IN}} = 2.5$ to $40\text{V}$ , $I_{\text{LOAD}} = 1\text{mA}$ , OUT = FB		0.01	0.05	%/V	
Load Regulation <sup>(7)</sup>		MPQ2013GQ, MPQ2013GG, $I_{\text{LOAD}} = 100\mu\text{A}$ to $150\text{mA}$ , OUT = FB, $V_{\text{IN}} = 3\text{V}$ to $6\text{V}$		0.003	0.005	%/mA	
		MPQ2013GQ-33, $I_{\text{LOAD}} = 100\mu\text{A}$ to $150\text{mA}$ , $V_{\text{IN}} = 4.3\text{V}$ to $6\text{V}$		0.005	0.015		
Output Voltage PSRR <sup>(8)</sup>		$100\text{Hz}$ , $C_{\text{IN}} = 100\text{pF}$ , $C_{\text{OUT}} = 4.7\mu\text{F}$ $I_{\text{LOAD}} = 10\text{mA}$ , $V_{\text{IN1}} = V_{\text{IN2}} = 6\text{V}$		58		dB	
		$1\text{kHz}$ , $C_{\text{IN}} = 100\text{pF}$ , $C_{\text{OUT}} = 4.7\mu\text{F}$ $I_{\text{LOAD}} = 10\text{mA}$ , $V_{\text{IN1}} = V_{\text{IN2}} = 6\text{V}$		41		dB	
		$100\text{kHz}$ , $C_{\text{IN}} = 100\text{pF}$ , $C_{\text{OUT}} = 4.7\mu\text{F}$ $I_{\text{LOAD}} = 10\text{mA}$ , $V_{\text{IN1}} = V_{\text{IN2}} = 6\text{V}$		55		dB	

## ELECTRICAL CHARACTERISTICS (continued)

Over operating junction temperature range ( $T_J = -40^{\circ}\text{C}$  to  $+125^{\circ}\text{C}$ ),  $V_{\text{OUT(NOM)}} = 5\text{V}$  ( $V_{\text{IN}} \geq 6\text{V}$ ) or FB ( $V_{\text{IN}} < 6\text{V}$ ) for MPQ2013,  $V_{\text{OUT(NOM)}} = 3.3\text{V}$  ( $V_{\text{IN}} \geq 4.3\text{V}$ ) or FB ( $V_{\text{IN}} < 4.3\text{V}$ ) for MPQ2013-33,  $I_{\text{OUT}} = 1\text{mA}$ ,  $C_{\text{OUT}} = 1\mu\text{F}$ , unless otherwise noted. Typical values are at  $T_J = +25^{\circ}\text{C}$ .

Parameter	Symbol	Condition	Min	Typ	Max	Units	
Startup Response Time		$R_{\text{LOAD}}=500\Omega$ , $C_{\text{OUT}}=6.8\mu\text{F}$ ,	$V_{\text{OUT}} = 3.3\text{V}$			1.8	ms
			$V_{\text{OUT}} = 5\text{V}$			3	
Thermal Shutdown <sup>(8)</sup>	$T_{\text{SD}}$		150	165		$^{\circ}\text{C}$	
Thermal Shutdown Hysteresis <sup>(8)</sup>	$\Delta T_{\text{SD}}$			20		$^{\circ}\text{C}$	

### Notes:

$$6) \text{ Line Regulation} = \frac{|V_{\text{OUT}[V_{\text{IN}(\text{MAX})}]} - V_{\text{OUT}[V_{\text{IN}(\text{MIN})}]}|}{(V_{\text{IN}(\text{MAX})} - V_{\text{IN}(\text{MIN})}) \times V_{\text{OUT}(\text{NOM})}} \times (\% / \text{V})$$

$$7) \text{ Load Regulation} = \frac{|V_{\text{OUT}[I_{\text{OUT}(\text{MAX})}]} - V_{\text{OUT}[I_{\text{OUT}(\text{MIN})}]}|}{(I_{\text{OUT}(\text{MAX})} - I_{\text{OUT}(\text{MIN})}) \times V_{\text{OUT}(\text{NOM})}} \times (\% / \text{mA})$$

8) Derived from bench characterization. Not tested in production.

## PIN FUNCTIONS

TSOT23-5	Pin #		Name	Description
	QFN6 (2x2mm)	QFN8 (3x3mm)		
3	1	1	IN1	Input Voltage. Connect a 2.5V to 40V supply to this pin.
2	2	2	IN2	VIN pin to power internal logic. Connect to IN1.
1	3, exposed pad	4, exposed pad	GND	Ground (the exposed pad and GND pin must be connected to the same ground plane)
5	4	5	FB	Feedback input pin, regulated to 1.215V nominally. Connected to an external resistive divider between OUT and GND to set output voltage. For fixed output version, this pin can be just float.
4	6	8	OUT	Regulated output voltage, only low-value ceramic capacitor ( $\geq 0.47\mu\text{F}$ ) on output is required for stability.
	5	3, 6, 7	NC	No connection. May be left open or tied to Ground for improved thermal performance.

## TYPICAL CHARACTERISTICS

**Dropout Voltage vs. Junction Temperature**

$V_{OUT}=5V$

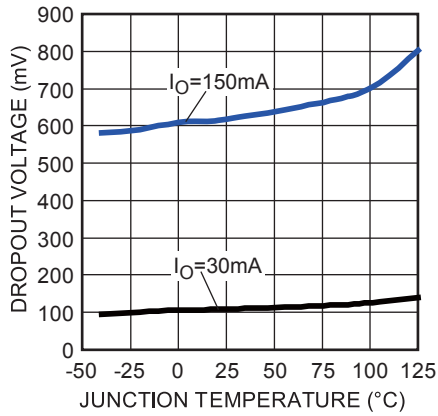

**Ground Current vs. Junction Temperature**

$V_{IN}=6V, V_{OUT}=5V$

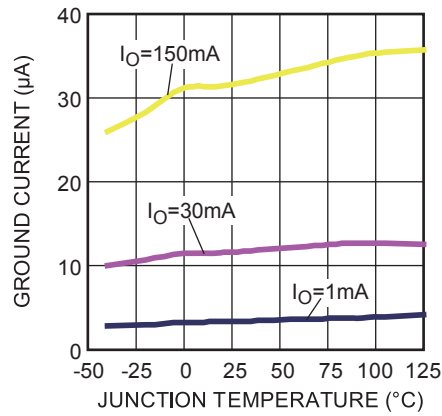

**Feedback Voltage vs. Junction Temperature**

$V_{IN}=6V$

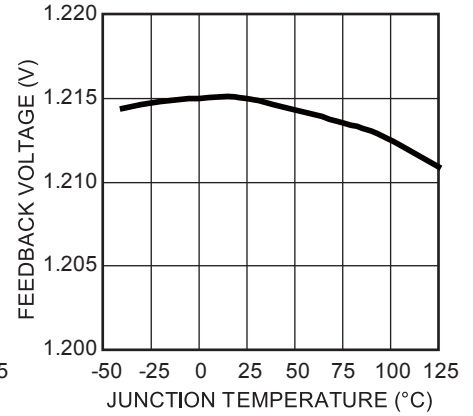

**Current Limit vs. Junction Temperature**

$V_{IN}=6V$

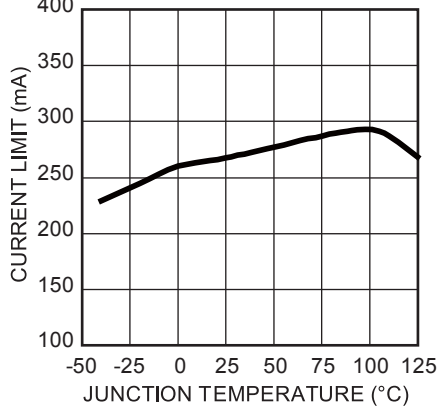

## TYPICAL PERFORMANCE CHARACTERISTICS

$C_{IN} = 1\mu F$ ,  $C_{OUT} = 4.7\mu F$ ,  $V_{OUT} = 5V$ ,  $T_A = +25^\circ C$ , unless otherwise noted

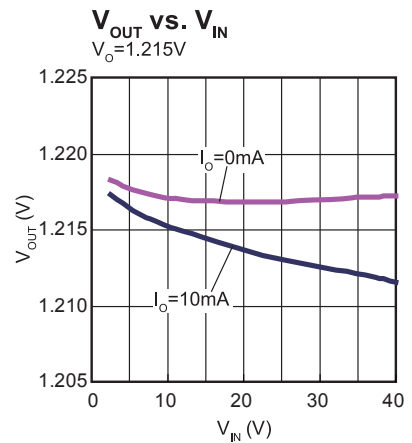
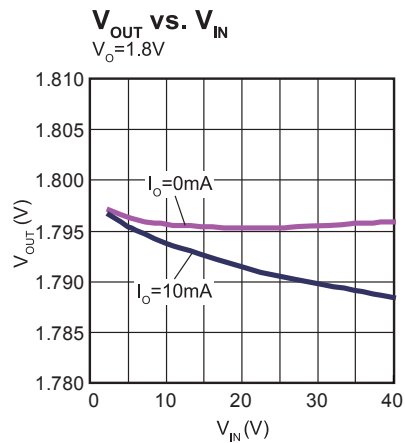
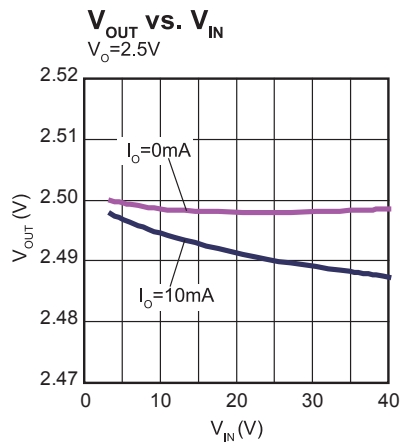
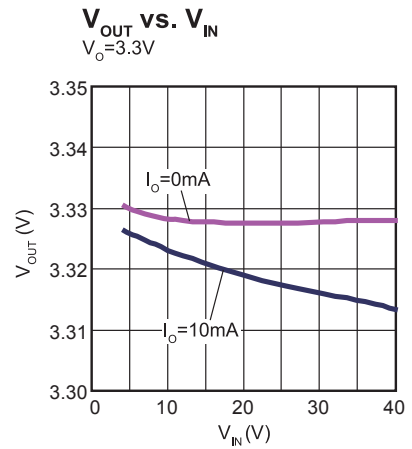
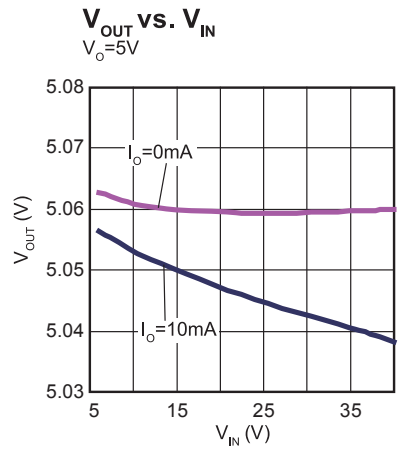
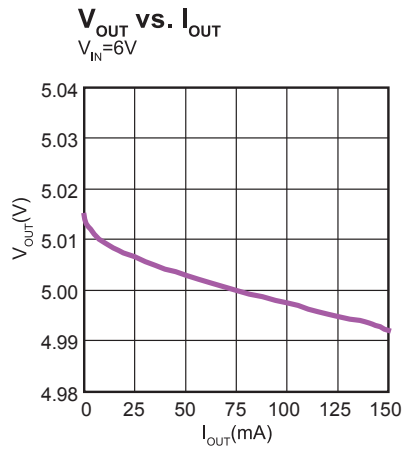
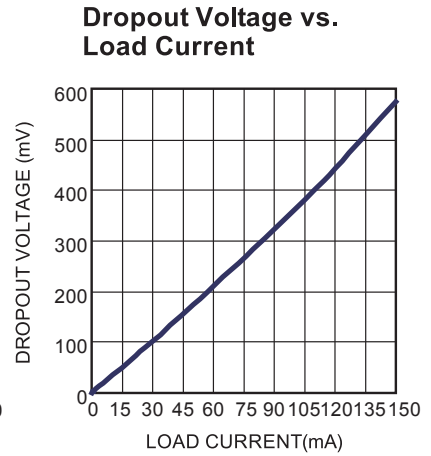
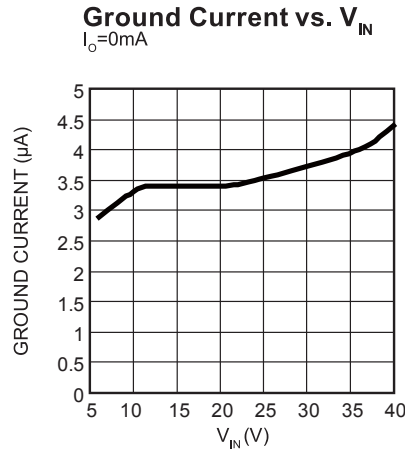
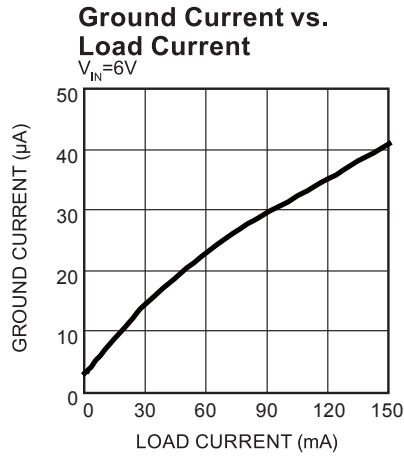

## TYPICAL PERFORMANCE CHARACTERISTICS (continued)

$C_{IN} = 1\mu F$ ,  $C_{OUT} = 4.7\mu F$ ,  $V_{OUT} = 5V$ ,  $T_A = +25^\circ C$ , unless otherwise noted

### PSRR vs. Frequency

$V_{IN1} = V_{IN2} = 6V$ ,  $I_O = 10mA$ ,  $C_{IN} = 100pF$

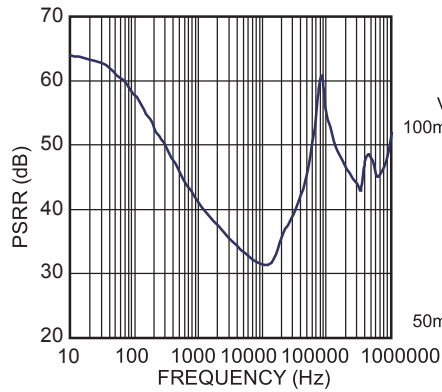

### Load Transient

$V_{IN} = 12V$ ,  $I_{OUT} = 8mA-150mA$

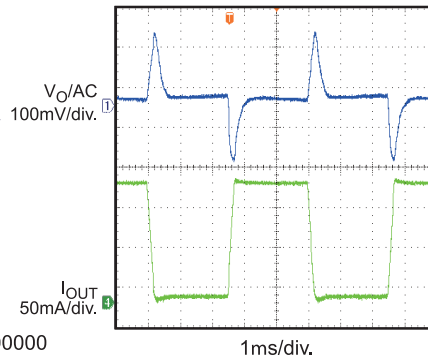

### Line Transient

$V_{IN} = 6V-7V$ ,  $I_{OUT} = 150mA$

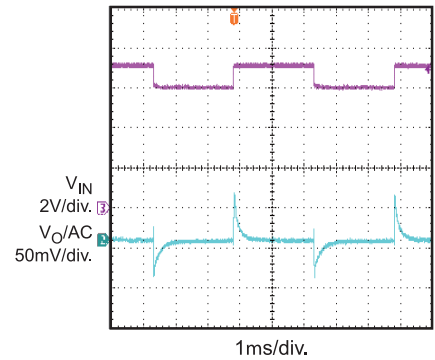

### Startup Through $V_{IN}$

$V_{IN} = 12V$ ,  $I_{OUT} = 150mA$

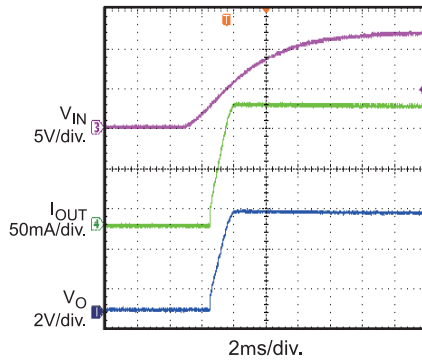

### Shutdown Through $V_{IN}$

$V_{IN} = 12V$ ,  $I_{OUT} = 150mA$

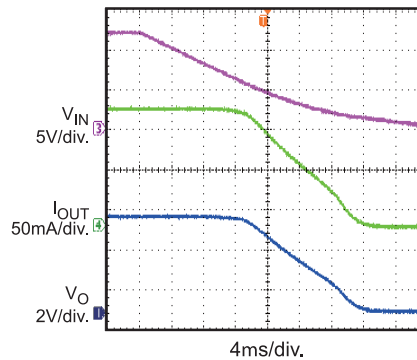

### Short Circuit Entry

$V_{IN} = 12V$ ,  $I_{OUT} = 0mA$  to short circuit

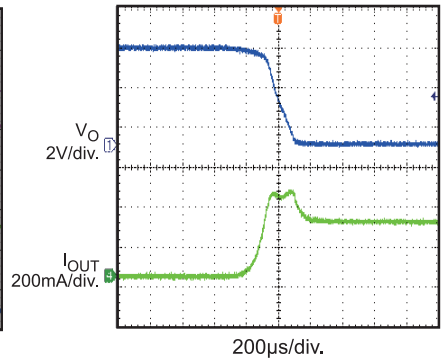

### Short Circuit Recovery

$V_{IN} = 12V$ , short circuit to  $I_{OUT} = 0mA$

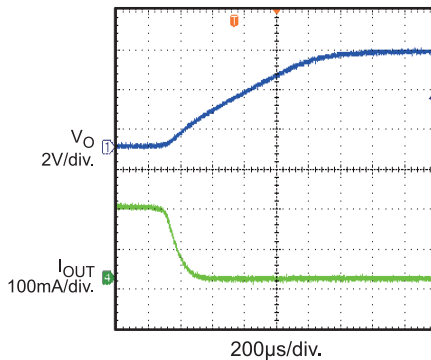

### Short Circuit Steady State

$V_{IN} = 12V$

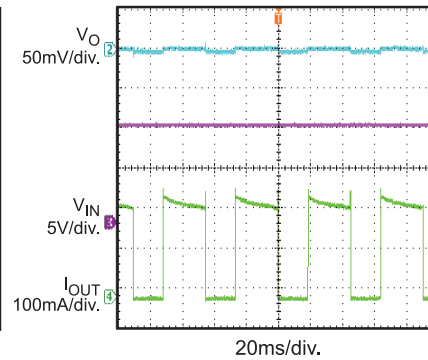



## OPERATION

The MPQ2013 is a linear regulator that supplies power to systems with high voltage batteries. It includes a wide 2.5V to 40V input range, low dropout voltage and low quiescent supply current.

The MPQ2013 provides wide variety of fixed output voltage options: 1.8V, 1.9V, 2.3V, 2.5V, 3.0V, 3.3V, 3.45V, 5.0V; and also provides the output adjustable option (from 1.215V to 15V).

The output adjustable version has an output that is adjustable from 1.215V to 15V with a simple resistor divider. It uses external feedback, allowing the user to set the output voltage with an external resistor divider. The typical FB pin voltage is 1.215V.

The regulator output current is internally limited and the device is protected against over-load and over-temperature conditions.

The peak output current is limited to around 270mA, which exceeds the 150mA recommended continuous output current.

When the junction temperature is too high, the thermal sensor sends a signal to the control logic that will shutdown the IC. The IC will restart when the temperature has sufficiently cooled.

The maximum power output current is a function of the package's maximum power dissipation for a given temperature.

The maximum power dissipation is dependent on the thermal resistance of the case and the circuit board, the temperature difference between the die junction and the ambient air, and the rate of air flow. The GND pin and Exposed Pad must be connected to the ground plane for proper dissipation.

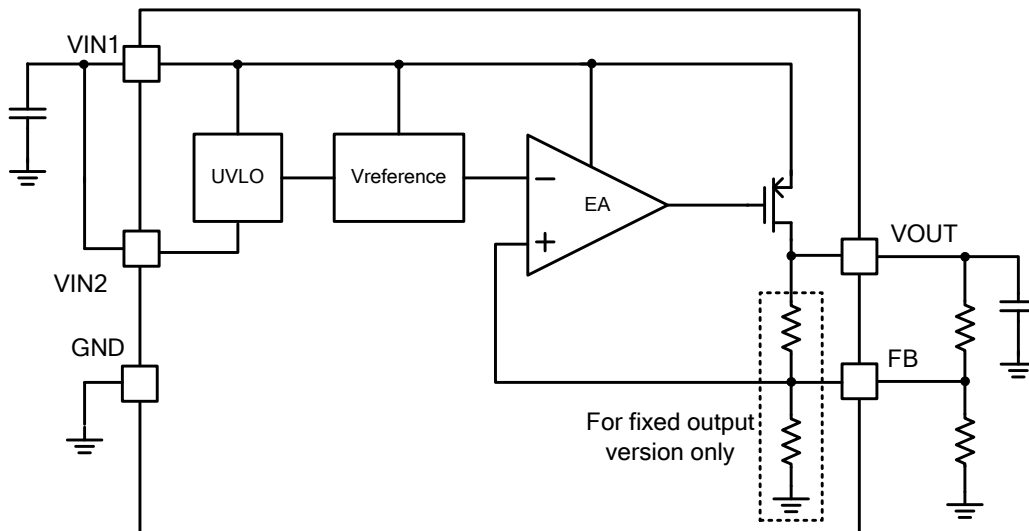

**Figure 1: Functional Block Diagram**

## APPLICATION INFORMATION

### COMPONENT SELECTION

#### Setting the Output Voltage

Set the output voltage of the MPQ2013 by using a resistor divider as shown:

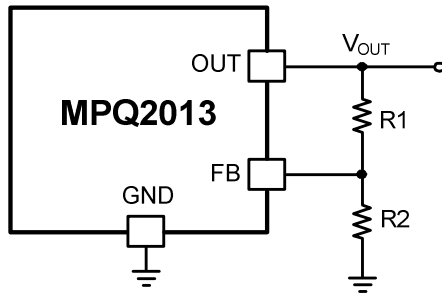
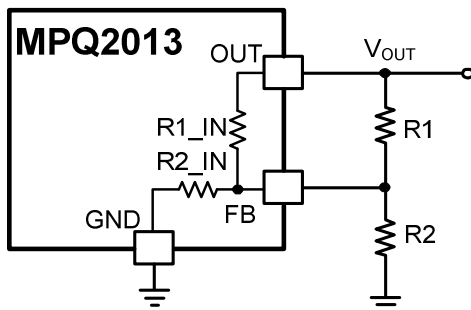

**Figure 2: FB Resistor Divider to Set  $V_{OUT}$**

Choose  $R2=1M\Omega$  to maintain a  $1.215\mu A$  minimum load. Calculate the value for  $R1$  using the following equation:

$$R1 = R2 \times \left( \frac{V_{OUT}}{1.215V} - 1 \right)$$

For fixed output version,  $V_{OUT}$  also can be adjusted by adding external resistor divider. Just note to take internal FB resistor divider into consideration when choose external divider.



**Figure 3: FB Divider of Fixed Output Version**

The internal FB resistor dividers for different fixed output versions please see below table.

**Table 1: Internal FB Resistor Divider**

Fixed Output Voltage	R1_IN	R2_IN
3.3V	1.72M $\Omega$	1M $\Omega$

#### Input Capacitor

For proper operation, place a ceramic capacitor ( $C1$ ) between  $1\mu F$  and  $10\mu F$  of dielectric type X5R or X7R between the input pin and ground. Larger values in this range will help improve line transient response.

#### Output Capacitor

For stable operation, use a ceramic capacitor ( $C2$ ) of type X5R or X7R between  $1\mu F$  and  $10\mu F$ . Larger values in this range will help improve load transient response and reduce noise. Output capacitors of other dielectric types may be used, but are not recommended as their capacitance can deviate greatly from their rated value over temperature.

To improve load transient response, add a small ceramic (X5R, X7R or Y5V dielectric) 22nF feed forward capacitor in parallel with  $R1$ . The feed forward capacitor is not required for stable operation.

#### OUTPUT NOISE

The MPQ2013 will exhibit noise on the output during normal operation. This noise is negligible for most applications. However, in applications that include analog-to-digital converters (ADCs) of more than 12 bits, one needs to consider the ADC's power supply rejection specifications. The feed forward capacitor  $C2$  across  $R1$  will significantly reduce the output noise.

#### PCB LAYOUT GUIDE

PCB layout is very important to achieve good regulation, ripple rejection, transient response and thermal performance. It is highly recommended to duplicate EVB layout for optimum performance.

If change is necessary, please follow these guidelines and take figure 5 for reference.

- 1) Input and output bypass ceramic capacitors are suggested to be put close to the IN Pin and OUT Pin respectively.
- 2) Ensure all feedback connections are short and direct. Place the feedback resistors and compensation components as close to the chip as possible.

- 3) Connect IN, OUT and especially GND respectively to a large copper area to cool the chip to improve thermal performance and long-term reliability.

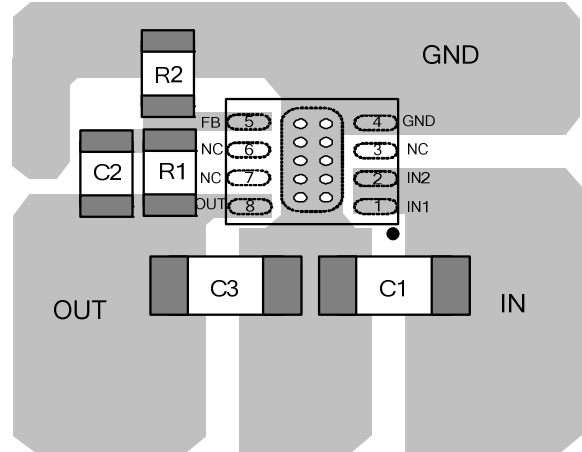
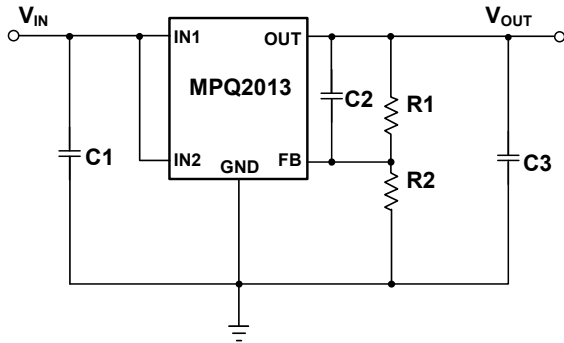
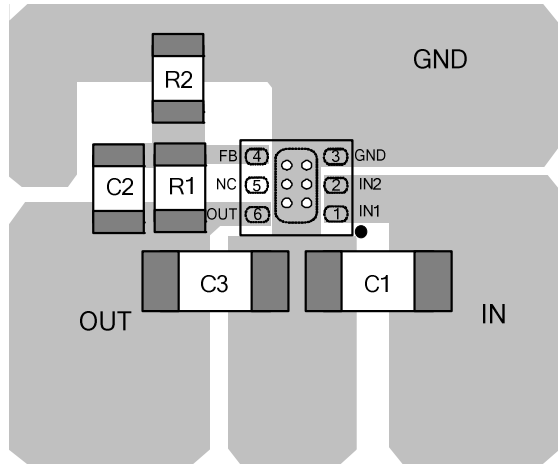
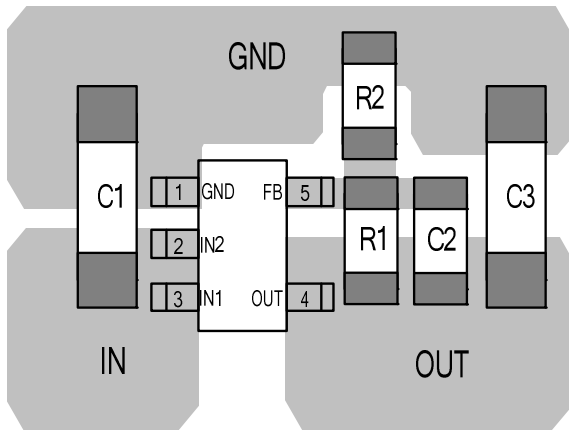

Figure 5: PCB Layout (Top Layer)



### DESIGN EXAMPLE

Below is a design example following the application guidelines for  $V_{OUT}=3.3V$  with feedforward cap.

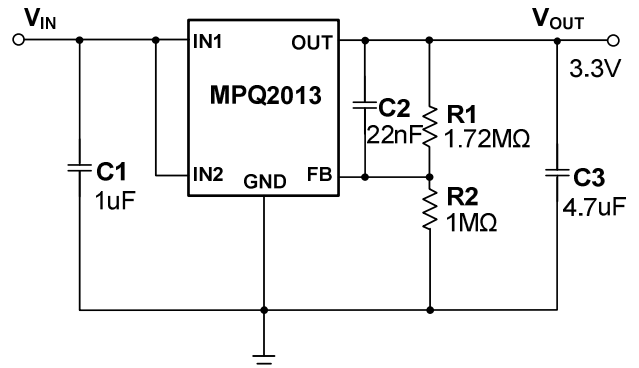

Figure 6: Design Example

## TYPICAL APPLICATION CIRCUITS

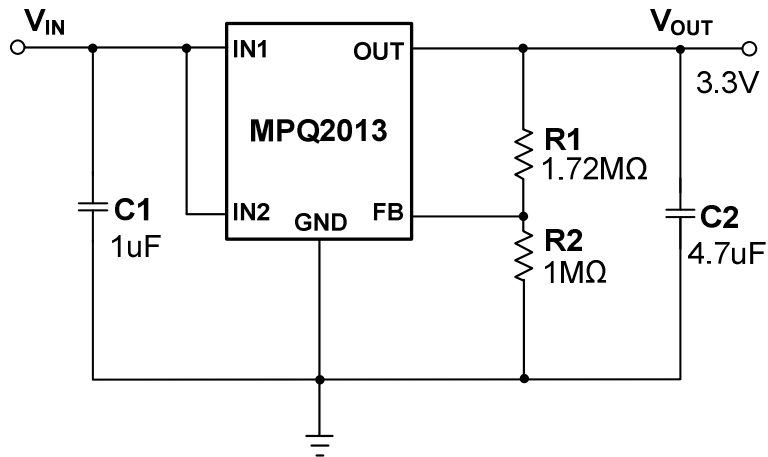

Figure 7: 3.3V Output Typical Application Circuit

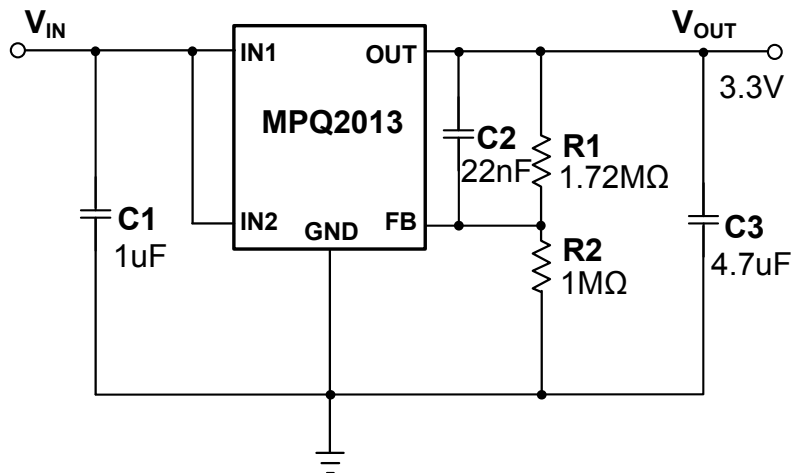

Figure 8: 3.3V Output with Feedforward Capacitor

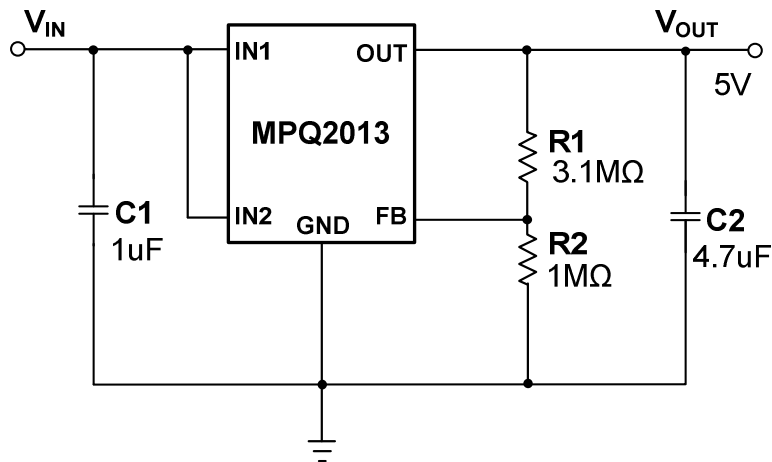
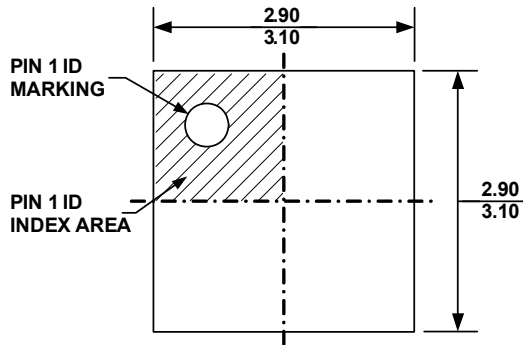

Figure 9: 5V Output Typical Application Circuit

# PACKAGE INFORMATION

## QFN8 (3x3mm)



**TOP VIEW**

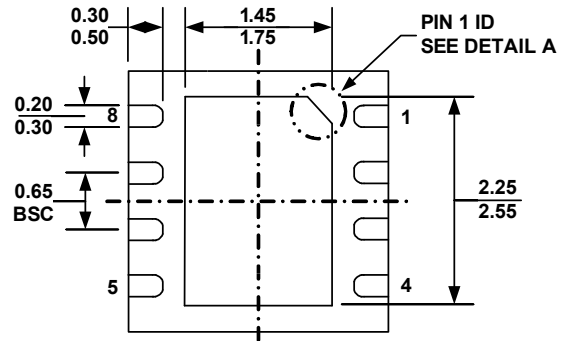

**BOTTOM VIEW**

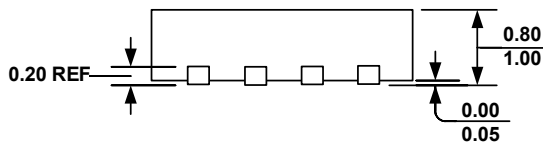

**SIDE VIEW**

**PIN 1 ID OPTION A**  
0.30x45° TYP.

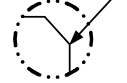

**PIN 1 ID OPTION B**  
R0.20 TYP.



**DETAIL A**

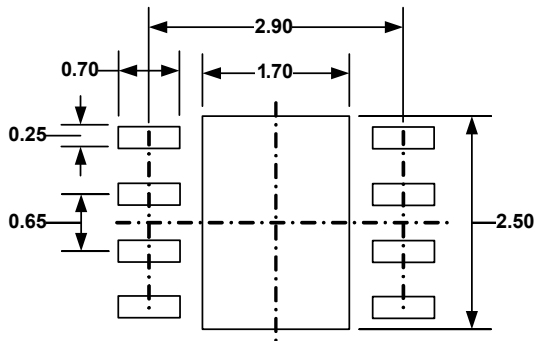

**RECOMMENDED LAND PATTERN**

**NOTE:**

- 1) ALL DIMENSIONS ARE IN MILLIMETERS
- 2) EXPOSED PADDLE SIZE DOES NOT INCLUDE MOLD FLASH
- 3) LEAD COPLANARITY SHALL BE 0.10 MILLIMETER MAX
- 4) JEDEC REFERENCE IS MO-229, VARIATION VEEC-2.
- 5) DRAWING IS NOT TO SCALE

### QFN6 (2x2mm)

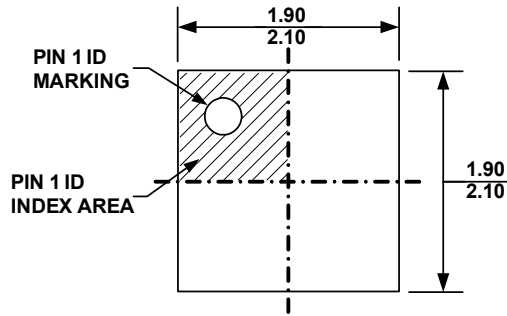

**TOP VIEW**

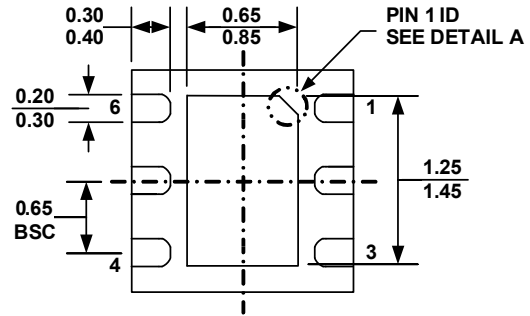

**BOTTOM VIEW**

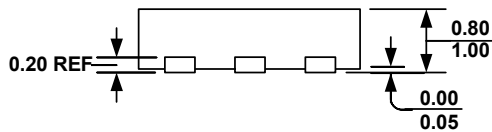

**SIDE VIEW**

PIN 1 ID OPTION A  
0.30x45° TYP.

PIN 1 ID OPTION B  
R0.20 TYP.

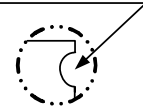
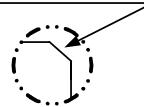

**DETAIL A**

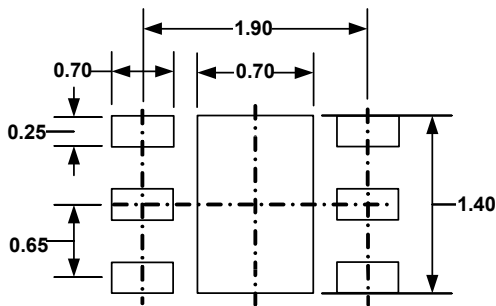

**RECOMMENDED LAND PATTERN**

**NOTE:**

- 1) ALL DIMENSIONS ARE IN MILLIMETERS
- 2) EXPOSED PADDLE SIZE DOES NOT INCLUDE MOLD FLASH
- 3) LEAD COPLANARITY SHALL BE 0.10 MILLIMETER MAX
- 4) JEDEC REFERENCE IS MO-229, VARIATION VCCC.
- 5) DRAWING IS NOT TO SCALE

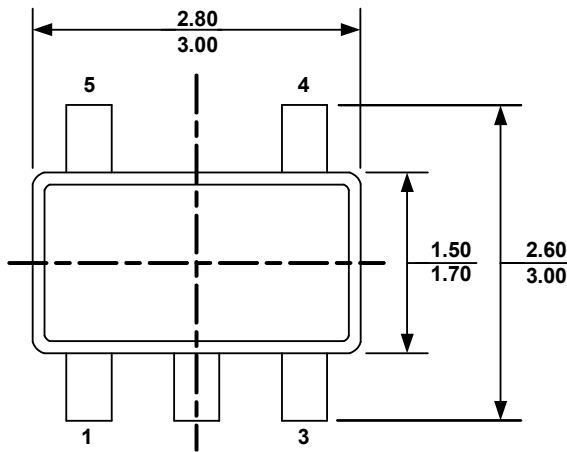
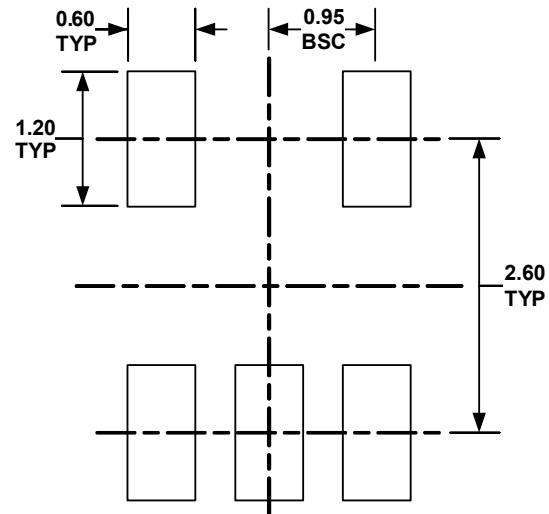
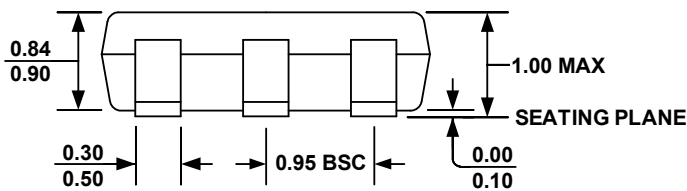
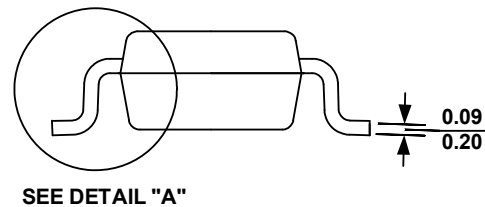
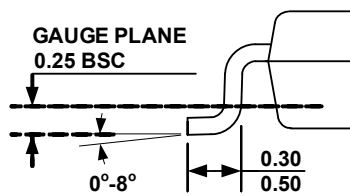
**TSOT23-5**

**TOP VIEW**

**RECOMMENDED LAND PATTERN**

**FRONT VIEW**

**SIDE VIEW**

**DETAIL "A"**
**NOTE:**

- 1) ALL DIMENSIONS ARE IN MILLIMETERS
- 2) PACKAGE LENGTH DOES NOT INCLUDE MOLD FLASH, PROTRUSION OR GATE BURR
- 3) PACKAGE WIDTH DOES NOT INCLUDE INTERLEAD FLASH OR PROTRUSION.
- 4) LEAD COPLANARITY (BOTTOM OF LEADS AFTER FORMING) SHALL BE 0.10 MILLIMETERS MAX
- 5) DRAWING CONFORMS TO JEDEC MO-193, VARIATION AA
- 6) DRAWING IS NOT TO SCALE

**NOTICE:** The information in this document is subject to change without notice. Please contact MPS for current specifications. Users should warrant and guarantee that third party Intellectual Property rights are not infringed upon when integrating MPS products into any application. MPS will not assume any legal responsibility for any said applications.