

MATERIAL NO.	NO. OF CIRCUITS	DIM. "A"		DIM. "B"	
387090133	12	101.0	3.98	90.8	3.58
387090135	18	150.5	5.93	140.3	5.53

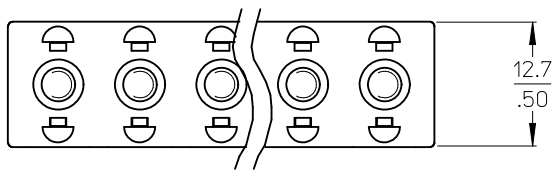
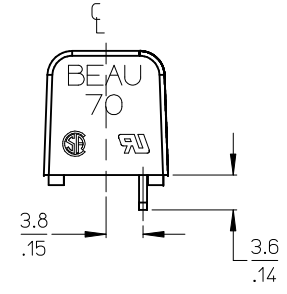
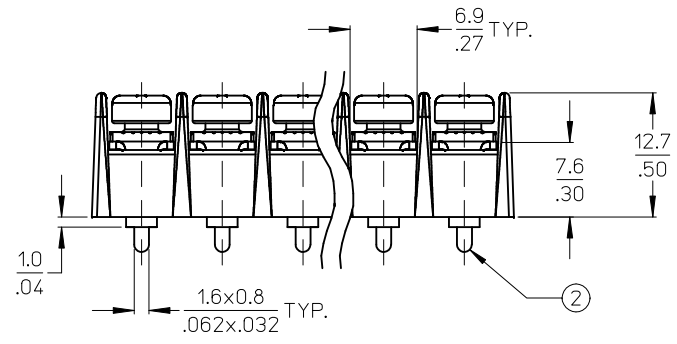
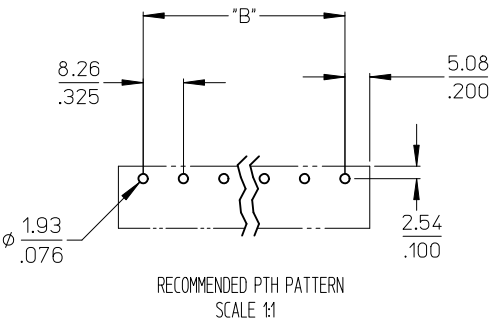
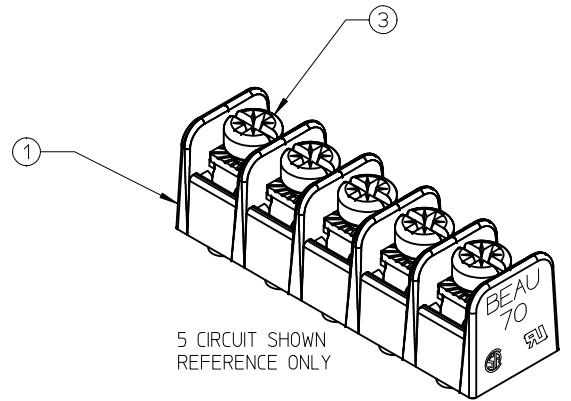
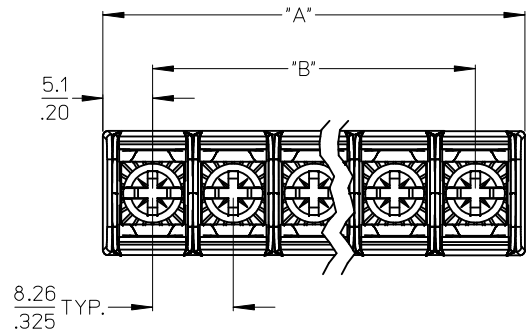

NOTES:

1. MATERIAL: SEE TABLE.
2. FINISHES: SEE TABLE.
3. PRODUCT SPECIFICATION: NOT REQUIRED.
4. "XX" REFERS TO THE QUANTITY OF CIRCUITS.
5. ASSEMBLY IS ROHS COMPLIANT.

ITEM	QTY.	DESCRIPTION	MATERIAL	FINISH
3	XX	SCREW, M3.5 X 0.6, POSI-SLOT, SQ. WASHER	STEEL	ZN, CLEAR CHROMATE
2	XX	TERMINAL PCKT	BRASS	TIN PLATE
1	1	BARRIER, MOLDING	POLYESTER (PBT)	BLACK

REDRAWN/UPDATE  
 EC NO: WNA2011-0628  
 DRAWN: JENCINAS 2011/06/21  
 CHKD: JMACNEIL 2011/06/21  
 APPR: JMACNEIL 2011/06/23

QUALITY SYMBOLS  
 ▼=0  
 ▽=0

	GENERAL TOLERANCES (UNLESS SPECIFIED)	
	mm	INCH
4 PLACES	± ---	± ---
3 PLACES	± ---	± .005
2 PLACES	± 0.13	± .010
1 PLACE	± 0.3	± ---
ANGULAR ± 2°		

DIMENSION STYLE: MM/IN  
 SCALE: 2:1  
 DESIGN UNITS: INCH  
 THIRD ANGLE PROJECTION  
 DRAWN BY: JENCINAS  
 DATE: 2011/06/21  
 CHECKED BY: JMACNEIL  
 DATE: 2011/06/21  
 APPROVED BY: JMACNEIL  
 DATE: 2011/06/23

TITLE: 8.26/.325" SR HIGH TEMP. BTS ASSY. W/ PC, PADS & CAPTIVE SCREW  
 MOLEX INCORPORATED  
 MATERIAL NO. SEE CHART  
 DOCUMENT NO. SD-38709-003  
 SHEET NO. 1 OF 1

DRAFT WHERE APPLICABLE MUST REMAIN WITHIN DIMENSIONS

THIS DRAWING CONTAINS INFORMATION THAT IS PROPRIETARY TO MOLEX INCORPORATED AND SHOULD NOT BE USED WITHOUT WRITTEN PERMISSION