

CKT SIZE	DIM A	DIM B	DIM C	DIM D
2	.165 (4.20)	.378 (9.60)	.520 (13.20)	.772 (19.60)
4	.496 (12.60)	.709 (18.00)	.850 (21.60)	1.102 (28.00)
5	.661 (16.80)	.874 (22.20)	1.016 (25.80)	1.268 (32.20)
6	.827 (21.00)	1.039 (26.40)	1.181 (30.00)	1.433 (36.40)
7	.992 (25.20)	1.205 (30.60)	1.346 (34.20)	1.598 (40.60)
8	1.157 (29.40)	1.370 (34.80)	1.512 (38.40)	1.764 (44.80)
9	1.323 (33.60)	1.535 (39.00)	1.677 (42.60)	1.929 (49.00)
10	1.488 (37.80)	1.701 (43.20)	1.843 (46.80)	2.094 (53.20)
11	1.654 (42.00)	1.866 (47.40)	2.008 (51.00)	2.260 (57.40)
12	1.819 (46.20)	2.031 (51.60)	2.173 (55.20)	2.425 (61.60)

- NOTES:**
- HOUSING MATERIAL:  
 "BLANK" = NYLON 6/6, U.L. 94V-2, COLOR: NATURAL.  
 210 = NYLON 6/6, U.L. 94V-0, COLOR: NATURAL.  
 BL = NYLON 6/6, U.L. 94V-2, COLOR: BLACK.  
 400 = NYLON 6/6, U.L. 94V-0, COLOR: BLACK.  
 TERMINAL MATERIAL: BRASS, ALLOY.
  - TERMINAL PLATING:  
 G, GS - .00030/(.00076) MIN. SELECT GOLD AND .000100/(.00127) MIN. SELECT MATTE TIN OVER .000050/(.00127) MIN NICKEL OVERALL.  
 G2, GS2 - .00015/(.00038) MIN. SELECT GOLD AND .000100/(.00254) MIN. SELECT MATTE TIN OVER .000050/(.00127) MIN. NICKEL OVERALL.  
 RM - .000060/(.00152) MIN REFLOWED MATTE TIN OVER .000050/(.00127) MIN. NICKEL OVERALL.
  - PRODUCT SPECIFICATION: PS-5556-001
  - PACKAGING SPECIFICATION : BULK PACK PER PK-5569-002 TRAY PACK PER PK-5569-005
  - PART MATES WITH MOLEX RECEPTACLE #5557.
  - PART IS DESIGNED FOR USE WITH #4 OR M3 SELF TAPPING SCREWS.
  - DISCOLORATION IN THE BANDOLIER CARRIER AREA OF THE PIN IS INHERENT TO THE PLATING PROCESS AND IS DUE TO THE MASKING EFFECT OF THE CARRIER. THIS DISCOLORATION IS IN A NON-FUNCTIONAL AREA OF THE PIN AND WILL NOT AFFECT THE PERFORMANCE OF THE HEADER ASSEMBLY.
  - CONNECTORS ARE NOT TO BE MATED OR UNMATED WHILE CIRCUIT ARE LIVE.
  - PARTS NOT DESIGNED FOR CURRENT SHARING.
  - PART CONFORMS TO CLASS "B" REQUIREMENTS OF COSMETIC SPECIFICATION PS-45499-002.
  - FORMING MARKS ON PINS ARE ACCEPTABLE
  - CORNER CORE-OUTS ARE OPTIONAL AND MAY OR MAY NOT BE PRESENT.
  - TEXT ON PART IS FOR REFERENCE ONLY. TEXT AND TEXT LOCATION MAY VARY DEPENDING ON PART NUMBER AND/OR TOOL.

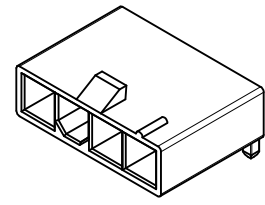
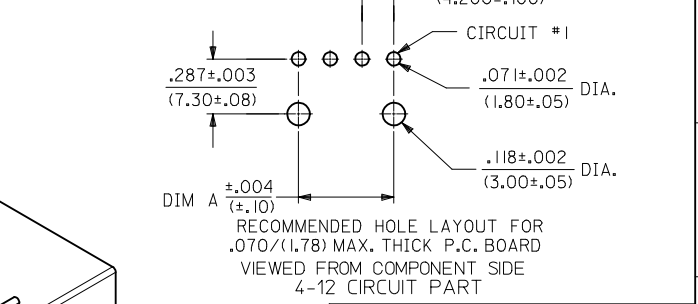
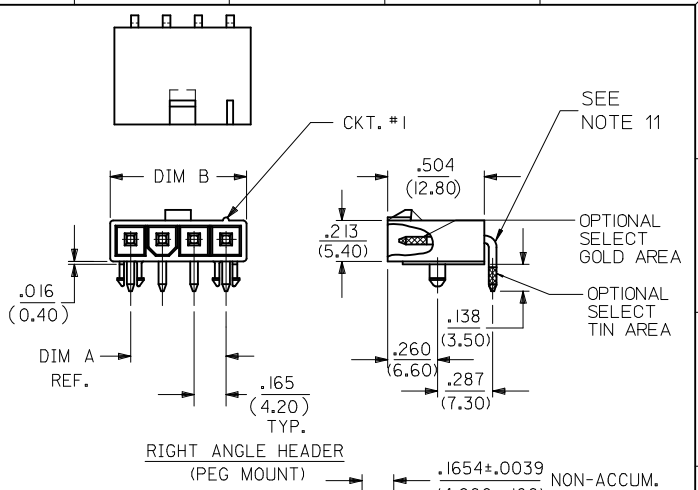
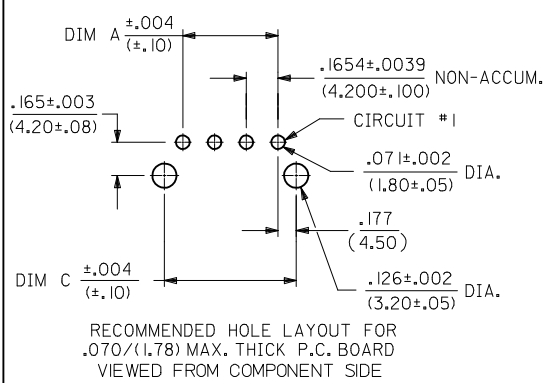
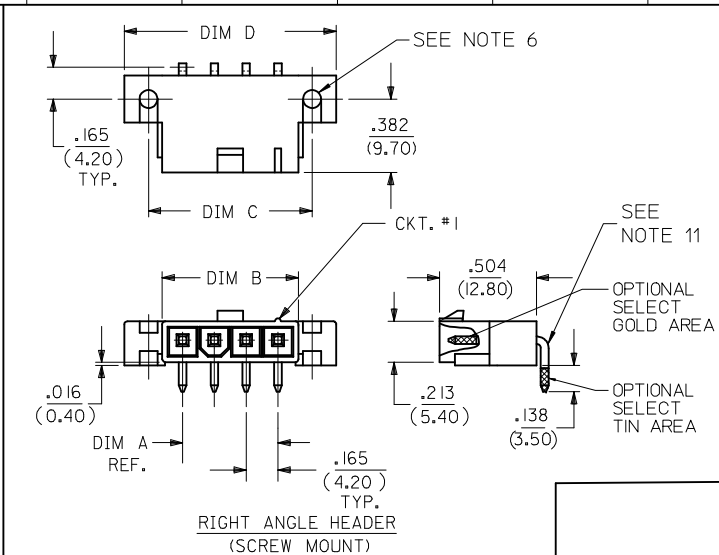

**LEGEND:**

5569 - \*\* A \* \* - \*

CKT. SIZE (02-12)

ASSEMBLY

MOUNTING & LOCK OPTION:  
 3 = SCREW MOUNT, POSITIVE LOCK  
 4 = PEG MOUNT, POSITIVE LOCK  
 5 = PEG MOUNT, PASSIVE LOCK

PLATING OPTION:  
 (SEE NOTE 2)

MATERIAL OPTION:  
 (SEE NOTE 1)

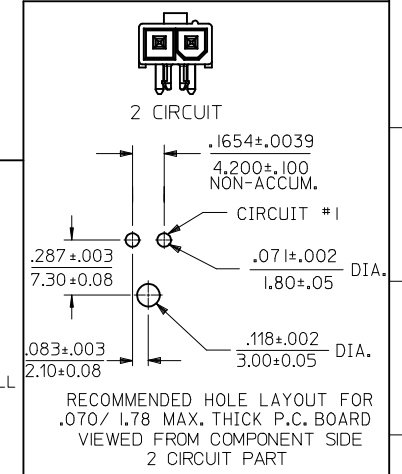
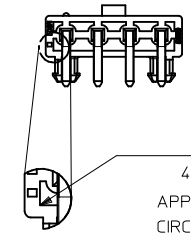

ADD 2 CKT VIEW EC NO: UCP2017-2789 DRAWN: APPELDORN 2017/06/26 CHKD: J.BELL 2017/06/26 APPR: FSM/TH 2017/06/28	QUALITY SYMBOLS ▽=0 ▽=0 ▽=0	GENERAL TOLERANCES (UNLESS SPECIFIED)		DIMENSION STYLE IN/MM		SCALE 2:1	DESIGN UNITS METRIC	THIRD ANGLE PROJECTION
		mm	INCH	DRAWN BY KSS	DATE 2/14/89	TITLE		
		4 PLACES ±	---	---		CHECKED BY RJF	DATE 2/14/89	RIGHT ANGLE HEADER ASSY (SINGLE ROW) (MINI-FIT JR. SERIES)
		3 PLACES ±	---	±.015		APPROVED BY RAS	DATE 2/14/89	
		2 PLACES ±	.38	±---				
		1 PLACE ±	---	---				RIGHT ANGLE HEADER ASSY (SINGLE ROW) (MINI-FIT JR. SERIES)
		0 PLACE ±	±	±				
		ANGULAR ± 3 °		MATERIAL NO. SEE CHARTS		DOCUMENT NO. SDA-5569-NL*		SHEET NO. 1 OF 2
DRAFT WHERE APPLICABLE MUST REMAIN WITHIN DIMENSIONS								
THIS DRAWING CONTAINS INFORMATION THAT IS PROPRIETARY TO MOLEX INCORPORATED AND SHOULD NOT BE USED WITHOUT WRITTEN PERMISSION								

UL94V-2							
E.D.P. NO.	ENG. NO.	CKT. SIZE	MOUNTING OPTION	LOCK OPTION	PLATING (SEE NOTE 2)	MAT'L. (SEE NOTE 1)	PACKAGING OPTION
SCREW MOUNT POSITIVE LOCK							
39-30-3041	5569-04A3MS	4	SCREWS	POSITIVE	TIN/NICKEL	94V-2	BULK
39-30-3051	5569-05A3MS	5	SCREWS	POSITIVE	TIN/NICKEL	94V-2	BULK
39-30-3043	5569-04A3GS	4	SCREWS	POSITIVE	30 GOLD	94V-2	BULK
39-30-3053	5569-05A3GS	5	SCREWS	POSITIVE	30 GOLD	94V-2	BULK
PEG MOUNT POSITIVE LOCK							
39-30-3045	5569-04A4	4	PEGS	POSITIVE	TIN/NICKEL	94V-2	BULK
39-30-3055	5569-05A4	5	PEGS	POSITIVE	TIN/NICKEL	94V-2	BULK
46999-0709	5569-02A4G	2	PEGS	POSITIVE	30 GOLD	94V-2	TRAY
39-30-3047	5569-04A4G	4	PEGS	POSITIVE	30 GOLD	94V-2	BULK
39-30-3057	5569-05A4G	5	PEGS	POSITIVE	30 GOLD	94V-2	BULK
46999-0710	5569-06A4G	6	PEGS	POSITIVE	30 GOLD	94V-2	TRAY
46999-0713	5569-02A4MS	2	PEGS	POSITIVE	TIN/NICKEL	94V-2	TRAY
46999-0100	5569-05A4MS	5	PEGS	POSITIVE	TIN/NICKEL	94V-2	BULK
46999-0714	5569-06A4MS	6	PEGS	POSITIVE	TIN/NICKEL	94V-2	TRAY
46999-0098	5569-05A4RM	5	PEGS	POSITIVE	REFLOW/NICKEL	94V-2	BULK
PEG MOUNT, PASSIVE LOCK							
NO E.D.P.	5569-04A5MS	4	PEGS	PASSIVE	TIN/NICKEL	94V-2	BULK
15-24-1501	5569-05A5MS	5	PEGS	PASSIVE	TIN/NICKEL	94V-2	BULK
NO E.D.P.	5569-04A5GS2	4	PEGS	PASSIVE	15 GOLD	94V-2	BULK
15-27-1501	5569-05A5GS2	5	PEGS	PASSIVE	15 GOLD	94V-2	BULK

UL94V-0							
E.D.P. NO.	ENG. NO.	CKT. SIZE	MOUNTING OPTION	LOCK OPTION	PLATING (SEE NOTE 2)	MAT'L. (SEE NOTE 1)	PACKAGING OPTION
SCREW MOUNT POSITIVE LOCK							
50-30-4469	5569-04A3MS-210	4	SCREW	POSITIVE	TIN/NICKEL	94V-0	BULK
NO E.D.P.	5569-05A3MS-210	5	SCREW	POSITIVE	TIN/NICKEL	94V-0	BULK
NO E.D.P.	5569-04A3GS-210	4	SCREW	POSITIVE	30 GOLD	94V-0	BULK
NO E.D.P.	5569-05A3GS-210	5	SCREW	POSITIVE	30 GOLD	94V-0	BULK
PEG MOUNT POSITIVE LOCK							
46999-0703	5569-02A4MS-210	2	PEGS	POSITIVE	TIN/NICKEL	94V-0	TRAY
39-30-3046	5569-04A4MS-210	4	PEGS	POSITIVE	TIN/NICKEL	94V-0	BULK
39-30-3056	5569-05A4MS-210	5	PEGS	POSITIVE	TIN/NICKEL	94V-0	BULK
46999-0704	5569-06A4MS-210	6	PEGS	POSITIVE	TIN/NICKEL	94V-0	TRAY
46999-0711	5569-02A4G-210	2	PEGS	POSITIVE	30 GOLD	94V-0	TRAY
39-30-3048	5569-04A4G-210	4	PEGS	POSITIVE	30 GOLD	94V-0	BULK
39-30-3058	5569-05A4G-210	5	PEGS	POSITIVE	30 GOLD	94V-0	BULK
46999-0712	5569-06A4G-210	6	PEGS	POSITIVE	30 GOLD	94V-0	TRAY
46999-0432	5569-04A4GS-400	4	PEGS	POSITIVE	30 GOLD	94V-0	BULK
50-30-4436	5569-05A4GS-400	5	PEGS	POSITIVE	30 GOLD	94V-0	BULK
46999-0707	5569-02A4MS-400	2	PEGS	POSITIVE	TIN/NICKEL	94V-0	TRAY
46999-0288	5569-04A4MS-400	4	PEGS	POSITIVE	TIN/NICKEL	94V-0	BULK
46999-0289	5569-05A4MS-400	5	PEGS	POSITIVE	TIN/NICKEL	94V-0	BULK
46999-0708	5569-06A4MS-400	6	PEGS	POSITIVE	TIN/NICKEL	94V-0	TRAY

13	12	11	10	9	8	7	6	5	4	3	2	1
----	----	----	----	---	---	---	---	---	---	---	---	---

<b>SEE SHEET 1</b> EC NO: UCP2017-2789 DRWING:APPELDORN 2017/06/26 CHKD: BELLI 2017/06/26 APPR:FSMITH 2017/06/28	QUALITY SYMBOLS 	GENERAL TOLERANCES (UNLESS SPECIFIED) <table border="1"> <tr> <th></th> <th>mm</th> <th>INCH</th> </tr> <tr> <td>4 PLACES</td> <td>± .---</td> <td>± .---</td> </tr> <tr> <td>3 PLACES</td> <td>± .---</td> <td>± .015</td> </tr> <tr> <td>2 PLACES</td> <td>± .38</td> <td>± .---</td> </tr> <tr> <td>1 PLACE</td> <td>± .---</td> <td>± .---</td> </tr> <tr> <td>0 PLACE</td> <td>±</td> <td>±</td> </tr> </table>		mm	INCH	4 PLACES	± .---	± .---	3 PLACES	± .---	± .015	2 PLACES	± .38	± .---	1 PLACE	± .---	± .---	0 PLACE	±	±	DIMENSION STYLE <b>IN/MM</b>	SCALE DRAWN BY: KSS DATE: 2/14/89 CHECKED BY: RJF DATE: 2/14/89 APPROVED BY: RAS DATE: 2/14/89	DESIGN UNITS <b>METRIC</b>	THIRD ANGLE PROJECTION 	TITLE <b>RIGHT ANGLE HEADER ASSY (SINGLE ROW) (MINI-FIT JR. SERIES)</b>	MATERIAL NO. <b>SEE CHART</b>	DOCUMENT NO. <b>SDA-5569-NL*</b>	SHEET NO. <b>2 OF 2</b>
				mm	INCH																							
4 PLACES	± .---	± .---																										
3 PLACES	± .---	± .015																										
2 PLACES	± .38	± .---																										
1 PLACE	± .---	± .---																										
0 PLACE	±	±																										
DRAFT WHERE APPLICABLE MUST REMAIN WITHIN DIMENSIONS		THIS DRAWING CONTAINS INFORMATION THAT IS PROPRIETARY TO MOLEX INCORPORATED AND SHOULD NOT BE USED WITHOUT WRITTEN PERMISSION																										