

Illustrations

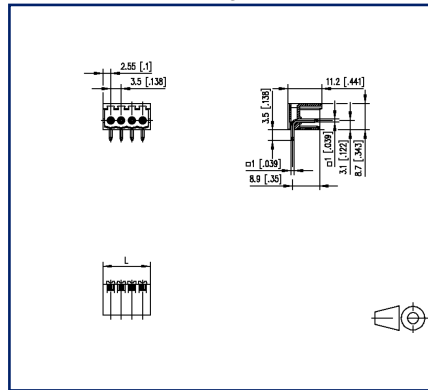

Dimensional drawing



Drill pattern

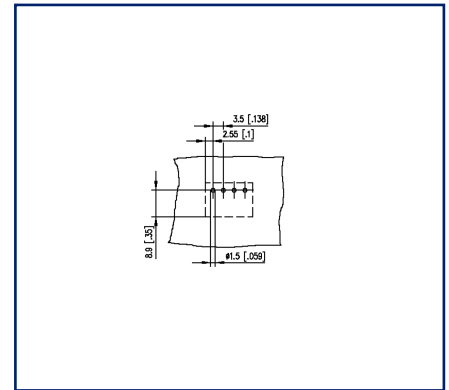



See enlarged drawings at the end of document

Product specification

- pin header, solderable
- centerline 3.50 mm, direction of connection 90°
- closed ends
- color black
- codeable

Technical Data

General Data			
Solder pin length	3.5 mm		
min. number of poles	2		
max. number of poles	18		
Insulating material class	CTI 600		
clearance/creepage dist.	2.5 mm		
Protection category	IP00		
Rated current	10 A		
Overvoltage category	III	III	II
Pollution degree	3	2	2
Rated voltage	200 V	500 V	500 V
Rated test voltage	2.5 kV	2.5 kV	2.5 kV
Approvals			
 V / A	300 / 10		
approval UL - File No.	E121004		
 1.5 mm ²	125 V / 2.5 kV / 5 A / 1.0 x 1.0 mm		
Material			
insulating material	PA66		
flammability class	V0		
contact pin material	CuFe		
contact pin surface	Ni + Ag		
Glow-Wire Flammability GWFI	960 °C acc. to IEC 60695-2-12		
Glow-Wire Flammability GWIT	775 °C acc. to IEC 60695-2-13		
REACH	compliant		
Climatic Data			
upper limit temperature	105 °C		
lower limit temperature	-40 °C		
general			
Tolerance	ISO 2768 -mH		
Solderability	Acc. to JEDEC JESD22-B102E 245°C/5s		

U | Contact

Data sheet
PT113xxHBBN Typ 182

Page 3/6

P/N
311821xx

xx=number of poles

2022/04/05

Version: Q

Accessories

P/N	Designation
720243-01-3	Coding star orange
720243-02-4	Coding star gray

© 2022 METZ CONNECT - Technische Änderungen vorbehalten! Subject to modifications! Sous réserve de modifications techniques!



U | Contact

Data sheet
PT113xxHBBN Typ 182

Page 4/6

P/N
311821xx

xx=number of poles

2022/04/05

Version: Q

Counterpart of

P/N	Designation
311691	RP013xxVBWN Typ 169



U | Contact

Data sheet PT113xxHBBN Typ 182

Page 5/6

P/N
311821xx

xx=number of poles

2022/04/05

Version: Q

Illustrations

Dimensional drawing

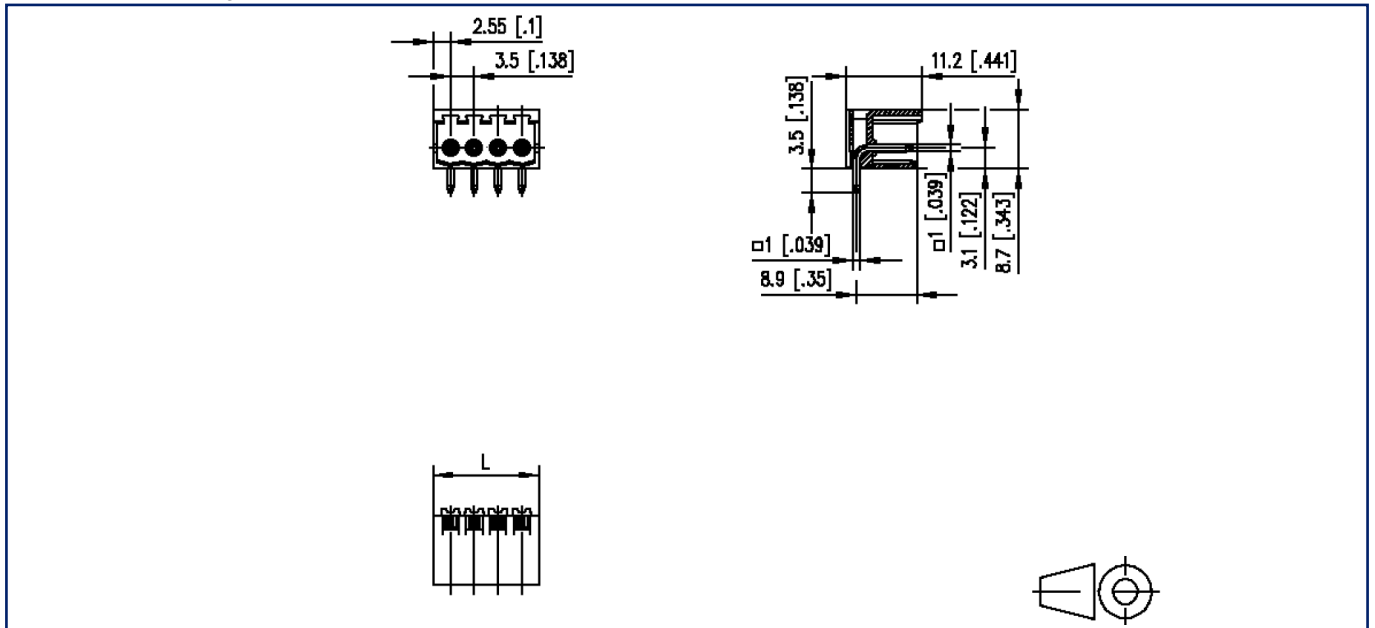

$L = (\text{pole size} - 1) \times \text{centerline} + 5.1 \text{ mm} [0.201]$

Illustrations

Drill pattern

