

Date: 03 Apr 2013

Product Category: 8-bit Microcontrollers

Device Family:  

Notification subject: Data Sheet - PIC32MX5XX/6XX/7XX Family Data Sheet Data Sheet Document Revision

Notification text: SYST-03PSRW649

Microchip has released a new DeviceDoc for the PIC32MX5XX/6XX/7XX Family Data Sheet of devices. If you are using one of these devices please read the document located at [PIC32MX5XX/6XX/7XX Family Data Sheet](#).

Notification Status: Final

Description of Change: Removed the shading for all D- and D+ pins in all pin diagrams. 1.0 “Device Overview” Updated the Vbus description in Table 1-1. 2.0 “Guidelines for Getting Started with 32-bit Microcontrollers” Added 2.11 “Referenced Sources”. 4.0 “Memory Organization” Added Note 3 to the Interrupt Register Map tables (see Table 4-2 through Table 4-7. 22.0 “10-bit Analog-to-Digital Converter (ADC)” Updated the ADC Conversion Clock Period Block Diagram (see Figure 22-2). 26.0 “Comparator Voltage Reference (CVref)” Updated the Comparator Voltage Reference Block Diagram (see Figure 26-1). 28.0 “Special Features” Removed the second paragraph from 28.3.1 “On-Chip Regulator and POR”. 31.0 “Electrical Characteristics” Added the new V-Temp temperature range (-40°C to +105°C) to the heading of all specification tables. Updated the Ambient temperature under bias, updated the Voltage on any 5V tolerant pin with respect to Vss when Vdd < 2.3V, and added Voltage on Vbus with respect to Vss in Absolute Maximum Ratings. Added the characteristic, DC5a to Operating MIPS vs. Voltage (see Table 31-1). Updated or added the following parameters to the Operating Current (Idd) DC Characteristics: DC20, DC20b, DC23, and DC23b (see Table 31-5). Added the following parameters to the Idle Current (Iidle) DC Characteristics: DC30b, DC33b, DC34c, DC35c, and DC36c (see Table 31-6). Added the following parameters to the Power-down Current (Ipd) DC Characteristics: DC40g, DC40h, DC40i, and DC41g, (see Table 31-7). Added parameter IM51 and Note 3 to the I2Cx Bus Data Timing Requirements (Master Mode) (see Table 31-32). Updated parameter AD57 (Tsamp) in the Analog-to-Digital Conversion Timing Requirements (see Table 31-38). 32.0 “Packaging Information” Updated the 64-Lead Plastic Quad Flat, No Lead Package (MR) – 9x9x0.9 mm Body [QFN] packing diagram. Product Identification System Added the new V-Temp (V) temperature information.

Pre Change: N/A

Post Change: N/A

Impacts to Data Sheet: None

Reason for Change: To Improve Productivity

Change Implementation Status: Complete

Date Document Changes Effective: 03 Apr 2013

NOTE: Please be advised that this is a change to the document only the product has not been changed..

Markings to Distinguish Revised from Unrevised Devices:N/A

Attachment(s): [PIC32MX5XX/6XX/7XX Family Data Sheet](#)

Please contact your local [Microchip sales office](#) with questions or concerns regarding this notification.

Terms and Conditions:

If you wish to change your product/process change notification (PCN) profile please log on to our website at <http://www.microchip.com/PCN> sign into myMICROCHIP to open the myMICROCHIP home page, then select a profile option from the left navigation bar.

To opt out of future offer or information emails (other than product change notification emails), click here to go to [microchipDIRECT](#) and login, then click on the "My account" link, click on "Update profile" and un-check the box that states "Future offers or information about Microchip's products or services."

Product Change Notification - SYST-03PSRW649

Parts Affected

PIC32MX795F512L
PIC32MX775F512L
PIC32MX795F512H
PIC32MX775F512H
PIC32MX775F256H
PIC32MX575F512L
PIC32MX575F512H
PIC32MX675F512H
PIC32MX675F256H
PIC32MX775F256L
PIC32MX675F512L
PIC32MX675F256L
PIC32MX575F256H
PIC32MX575F256L
PIC32MX695F512H
PIC32MX695F512L
PIC32MX664F064L
PIC32MX564F128L
PIC32MX764F128L
PIC32MX664F128L
PIC32MX534F064L
PIC32MX564F064L
PIC32MX534F064H
PIC32MX564F064H
PIC32MX664F064H
PIC32MX564F128H
PIC32MX664F128H
PIC32MX764F128H



MICROCHIP

PIC32MX5XX/6XX/7XX
Family Data Sheet

High-Performance, USB, CAN and Ethernet
32-bit Flash Microcontrollers

Note the following details of the code protection feature on Microchip devices:

- Microchip products meet the specification contained in their particular Microchip Data Sheet.
- Microchip believes that its family of products is one of the most secure families of its kind on the market today, when used in the intended manner and under normal conditions.
- There are dishonest and possibly illegal methods used to breach the code protection feature. All of these methods, to our knowledge, require using the Microchip products in a manner outside the operating specifications contained in Microchip's Data Sheets. Most likely, the person doing so is engaged in theft of intellectual property.
- Microchip is willing to work with the customer who is concerned about the integrity of their code.
- Neither Microchip nor any other semiconductor manufacturer can guarantee the security of their code. Code protection does not mean that we are guaranteeing the product as "unbreakable."

Code protection is constantly evolving. We at Microchip are committed to continuously improving the code protection features of our products. Attempts to break Microchip's code protection feature may be a violation of the Digital Millennium Copyright Act. If such acts allow unauthorized access to your software or other copyrighted work, you may have a right to sue for relief under that Act.

Information contained in this publication regarding device applications and the like is provided only for your convenience and may be superseded by updates. It is your responsibility to ensure that your application meets with your specifications. MICROCHIP MAKES NO REPRESENTATIONS OR WARRANTIES OF ANY KIND WHETHER EXPRESS OR IMPLIED, WRITTEN OR ORAL, STATUTORY OR OTHERWISE, RELATED TO THE INFORMATION, INCLUDING BUT NOT LIMITED TO ITS CONDITION, QUALITY, PERFORMANCE, MERCHANTABILITY OR FITNESS FOR PURPOSE. Microchip disclaims all liability arising from this information and its use. Use of Microchip devices in life support and/or safety applications is entirely at the buyer's risk, and the buyer agrees to defend, indemnify and hold harmless Microchip from any and all damages, claims, suits, or expenses resulting from such use. No licenses are conveyed, implicitly or otherwise, under any Microchip intellectual property rights.

Trademarks

The Microchip name and logo, the Microchip logo, dsPIC, KEELOQ, KEELOQ logo, MPLAB, PIC, PICmicro, PICSTART, PIC³² logo, rPIC and UNI/O are registered trademarks of Microchip Technology Incorporated in the U.S.A. and other countries.

FilterLab, Hampshire, HI-TECH C, Linear Active Thermistor, MXDEV, MXLAB, SEEVAL and The Embedded Control Solutions Company are registered trademarks of Microchip Technology Incorporated in the U.S.A.

Analog-for-the-Digital Age, Application Maestro, CodeGuard, dsPICDEM, dsPICDEM.net, dsPICworks, dsSPEAK, ECAN, ECONOMONITOR, FanSense, HI-TIDE, In-Circuit Serial Programming, ICSP, Mindi, MiWi, MPASM, MPLAB Certified logo, MPLIB, MPLINK, mTouch, Omniscient Code Generation, PICC, PICC-18, PICDEM, PICDEM.net, PICKit, PICTail, REAL ICE, rLAB, Select Mode, Total Endurance, TSHARC, UniWinDriver, WiperLock and ZENA are trademarks of Microchip Technology Incorporated in the U.S.A. and other countries.

SQTP is a service mark of Microchip Technology Incorporated in the U.S.A.

All other trademarks mentioned herein are property of their respective companies.

© 2009-2011, Microchip Technology Incorporated, Printed in the U.S.A., All Rights Reserved.

 Printed on recycled paper.

ISBN: 978-1-61341-150-6

Microchip received ISO/TS-16949:2002 certification for its worldwide headquarters, design and wafer fabrication facilities in Chandler and Tempe, Arizona; Gresham, Oregon and design centers in California and India. The Company's quality system processes and procedures are for its PIC[®] MCUs and dsPIC[®] DSCs, KEELOQ[®] code hopping devices, Serial EEPROMs, microperipherals, nonvolatile memory and analog products. In addition, Microchip's quality system for the design and manufacture of development systems is ISO 9001:2000 certified.

**QUALITY MANAGEMENT SYSTEM
CERTIFIED BY DNV
== ISO/TS 16949:2002 ==**



PIC32MX5XX/6XX/7XX

High-Performance, USB, CAN and Ethernet 32-bit Flash Microcontrollers

High-Performance 32-bit RISC CPU:

- MIPS32[®] M4K[®] 32-bit core with 5-stage pipeline
- 80 MHz maximum frequency
- 1.56 DMIPS/MHz (Dhrystone 2.1) performance at zero Wait state Flash access
- Single-cycle multiply and high-performance divide unit
- MIPS16e[®] mode for up to 40% smaller code size
- Two sets of 32 core register files (32-bit) to reduce interrupt latency
- Prefetch Cache module to speed execution from Flash

Microcontroller Features:

- Operating voltage range of 2.3V to 3.6V
- 64K to 512K Flash memory (plus an additional 12 KB of Boot Flash)
- 16K to 128K SRAM memory
- Pin-compatible with most PIC24/dsPIC[®] DSC devices
- Multiple power management modes
- Multiple interrupt vectors with individually programmable priority
- Fail-Safe Clock Monitor mode
- Configurable Watchdog Timer with on-chip Low-Power RC oscillator for reliable operation

Peripheral Features:

- Atomic SET, CLEAR and INVERT operation on select peripheral registers
- Up to 8-channels of hardware DMA with automatic data size detection
- USB 2.0-compliant full-speed device and On-The-Go (OTG) controller:
 - Dedicated DMA channels
- 10/100 Mbps Ethernet MAC with MII and RMII interface:
 - Dedicated DMA channels
- CAN module:
 - 2.0B Active with DeviceNet[™] addressing support
 - Dedicated DMA channels
- 3 MHz to 25 MHz crystal oscillator

Peripheral Features (Continued):

- Internal 8 MHz and 32 kHz oscillators
- Six UART modules with:
 - RS-232, RS-485 and LIN support
 - IrDA[®] with on-chip hardware encoder and decoder
- Up to four SPI modules
- Up to five I²C[™] modules
- Separate PLLs for CPU and USB clocks
- Parallel Master and Slave Port (PMP/PSP) with 8-bit and 16-bit data, and up to 16 address lines
- Hardware Real-Time Clock and Calendar (RTCC)
- Five 16-bit Timers/Counters (two 16-bit pairs combine to create two 32-bit timers)
- Five Capture inputs
- Five Compare/PWM outputs
- Five external interrupt pins
- High-speed I/O pins capable of toggling at up to 80 MHz
- High-current sink/source (18 mA/18 mA) on all I/O pins
- Configurable open-drain output on digital I/O pins

Debug Features:

- Two programming and debugging Interfaces:
 - 2-wire interface with unintrusive access and real-time data exchange with application
 - 4-wire MIPS[®] standard enhanced Joint Test Action Group (JTAG) interface
- Unintrusive hardware-based instruction trace
- IEEE Standard 1149.2 compatible (JTAG) boundary scan

Analog Features:

- Up to 16-channel, 10-bit Analog-to-Digital Converter:
 - 1 Msps conversion rate
 - Conversion available during Sleep and Idle
- Two Analog Comparators

PIC32MX5XX/6XX/7XX

TABLE 1: PIC32 USB AND CAN – FEATURES

USB and CAN																
Device	Pins	Program Memory (KB)	Data Memory (KB)	USB	CAN	Timers/Capture/Compare	DMA Channels (Programmable/Dedicated)	UART ^(2,3)	SPI ⁽³⁾	I ² C ^{TM(3)}	10-bit 1 Msps ADC (Channels)	Comparators	PMP/PSP	JTAG	Trace	Packages ⁽⁴⁾
PIC32MX534F064H	64	64 + 12 ⁽¹⁾	16	1	1	5/5/5	4/4	6	3	4	16	2	Yes	Yes	No	PT, MR
PIC32MX564F064H	64	64 + 12 ⁽¹⁾	32	1	1	5/5/5	4/4	6	3	4	16	2	Yes	Yes	No	PT, MR
PIC32MX564F128H	64	128 + 12 ⁽¹⁾	32	1	1	5/5/5	4/4	6	3	4	16	2	Yes	Yes	No	PT, MR
PIC32MX575F256H	64	256 + 12 ⁽¹⁾	64	1	1	5/5/5	8/4	6	3	4	16	2	Yes	Yes	No	PT, MR
PIC32MX575F512H	64	512 + 12 ⁽¹⁾	64	1	1	5/5/5	8/4	6	3	4	16	2	Yes	Yes	No	PT, MR
PIC32MX534F064L	100	64 + 12 ⁽¹⁾	16	1	1	5/5/5	4/4	6	4	5	16	2	Yes	Yes	Yes	PT, PF, BG
PIC32MX564F064L	100	64 + 12 ⁽¹⁾	32	1	1	5/5/5	4/4	6	4	5	16	2	Yes	Yes	Yes	PT, PF, BG
PIC32MX564F128L	100	128 + 12 ⁽¹⁾	32	1	1	5/5/5	4/4	6	4	5	16	2	Yes	Yes	Yes	PT, PF, BG
PIC32MX575F256L	100	256 + 12 ⁽¹⁾	64	1	1	5/5/5	8/4	6	4	5	16	2	Yes	Yes	Yes	PT, PF, BG
PIC32MX575F512L	100	512 + 12 ⁽¹⁾	64	1	1	5/5/5	8/4	6	4	5	16	2	Yes	Yes	Yes	PT, PF, BG

Legend: PF, PT = TQFP MR = QFN BG = XBGA

- Note** 1: This device features 12 KB boot Flash memory.
 2: CTS and RTS pins may not be available for all UART modules. Refer to the **“Pin Diagrams”** section for more information.
 3: Some pins between the UART, SPI and I²C modules may be shared. Refer to the **“Pin Diagrams”** section for more information.
 4: Refer to **Section 32.0 “Packaging Information”** for more information.

TABLE 2: PIC32 USB AND ETHERNET – FEATURES

USB and Ethernet																
Device	Pins	Program Memory (KB)	Data Memory (KB)	USB	Ethernet	Timers/Capture/Compare	DMA Channels (Programmable/Dedicated)	UART ^(2,3)	SPI ⁽³⁾	I ² C™ ⁽³⁾	10-bit 1 Msps ADC (Channels)	Comparators	PMP/PSP	JTAG	Trace	Packages ⁽⁴⁾
PIC32MX664F064H	64	64 + 12 ⁽¹⁾	32	1	1	5/5/5	4/4	6	3	4	16	2	Yes	Yes	No	PT, MR
PIC32MX664F128H	64	128 + 12 ⁽¹⁾	32	1	1	5/5/5	4/4	6	3	4	16	2	Yes	Yes	No	PT, MR
PIC32MX675F256H	64	256 + 12 ⁽¹⁾	64	1	1	5/5/5	8/4	6	3	4	16	2	Yes	Yes	No	PT, MR
PIC32MX675F512H	64	512 + 12 ⁽¹⁾	64	1	1	5/5/5	8/4	6	3	4	16	2	Yes	Yes	No	PT, MR
PIC32MX695F512H	64	512 + 12 ⁽¹⁾	128	1	1	5/5/5	8/4	6	3	4	16	2	Yes	Yes	No	PT, MR
PIC32MX664F064L	100	64 + 12 ⁽¹⁾	32	1	1	5/5/5	4/4	6	4	5	16	2	Yes	Yes	Yes	PT, PF, BG
PIC32MX664F128L	100	128 + 12 ⁽¹⁾	32	1	1	5/5/5	4/4	6	4	5	16	2	Yes	Yes	Yes	PT, PF, BG
PIC32MX675F256L	100	256 + 12 ⁽¹⁾	64	1	1	5/5/5	8/4	6	4	5	16	2	Yes	Yes	Yes	PT, PF, BG
PIC32MX675F512L	100	512 + 12 ⁽¹⁾	64	1	1	5/5/5	8/4	6	4	5	16	2	Yes	Yes	Yes	PT, PF, BG
PIC32MX695F512L	100	512 + 12 ⁽¹⁾	128	1	1	5/5/5	8/4	6	4	5	16	2	Yes	Yes	Yes	PT, PF, BG

Legend: PF, PT = TQFP MR = QFN BG = XBGA

Note 1: This device features 12 KB boot Flash memory.

Note 2: CTS and RTS pins may not be available for all UART modules. Refer to the “[Pin Diagrams](#)” section for more information.

Note 3: Some pins between the UART, SPI and I²C modules may be shared. Refer to the “[Pin Diagrams](#)” section for more information.

Note 4: Refer to [Section 32.0 “Packaging Information”](#) for more information.

PIC32MX5XX/6XX/7XX

TABLE 3: PIC32 USB, ETHERNET AND CAN – FEATURES

USB, Ethernet and CAN																	
Device	Pins	Program Memory (KB)	Data Memory (KB)	USB	Ethernet	CAN	Timers/Capture/Compare	DMA Channels (Programmable/Dedicated)	UART ^(2,3)	SPI ⁽³⁾	I ² C ^{TM(3)}	10-bit 1 Msps ADC (Channels)	Comparators	PMP/PSP	JTAG	Trace	Packages ⁽⁴⁾
PIC32MX764F128H	64	128 + 12 ⁽¹⁾	32	1	1	1	5/5/5	4/6	6	3	4	16	2	Yes	Yes	No	PT, MR
PIC32MX775F256H	64	256 + 12 ⁽¹⁾	64	1	1	2	5/5/5	8/8	6	3	4	16	2	Yes	Yes	No	PT, MR
PIC32MX775F512H	64	512 + 12 ⁽¹⁾	64	1	1	2	5/5/5	8/8	6	3	4	16	2	Yes	Yes	No	PT, MR
PIC32MX795F512H	64	512 + 12 ⁽¹⁾	128	1	1	2	5/5/5	8/8	6	3	4	16	2	Yes	Yes	No	PT, MR
PIC32MX764F128L	100	128 + 12 ⁽¹⁾	32	1	1	1	5/5/5	4/6	6	4	5	16	2	Yes	Yes	Yes	PT, PF, BG
PIC32MX775F256L	100	256 + 12 ⁽¹⁾	64	1	1	2	5/5/5	8/8	6	4	5	16	2	Yes	Yes	Yes	PT, PF, BG
PIC32MX775F512L	100	512 + 12 ⁽¹⁾	64	1	1	2	5/5/5	8/8	6	4	5	16	2	Yes	Yes	Yes	PT, PF, BG
PIC32MX795F512L	100	512 + 12 ⁽¹⁾	128	1	1	2	5/5/5	8/8	6	4	5	16	2	Yes	Yes	Yes	PT, PF, BG

Legend: PF, PT = TQFP MR = QFN BG = XBGA

- Note** 1: This device features 12 KB boot Flash memory.
 2: CTS and RTS pins may not be available for all UART modules. Refer to the “[Pin Diagrams](#)” section for more information.
 3: Some pins between the UART, SPI and I²C modules may be shared. Refer to the “[Pin Diagrams](#)” section for more information.
 4: Refer to [Section 32.0 “Packaging Information”](#) for more information.

Pin Diagrams

64-Pin QFN⁽¹⁾

■ = Pins are up to 5V tolerant

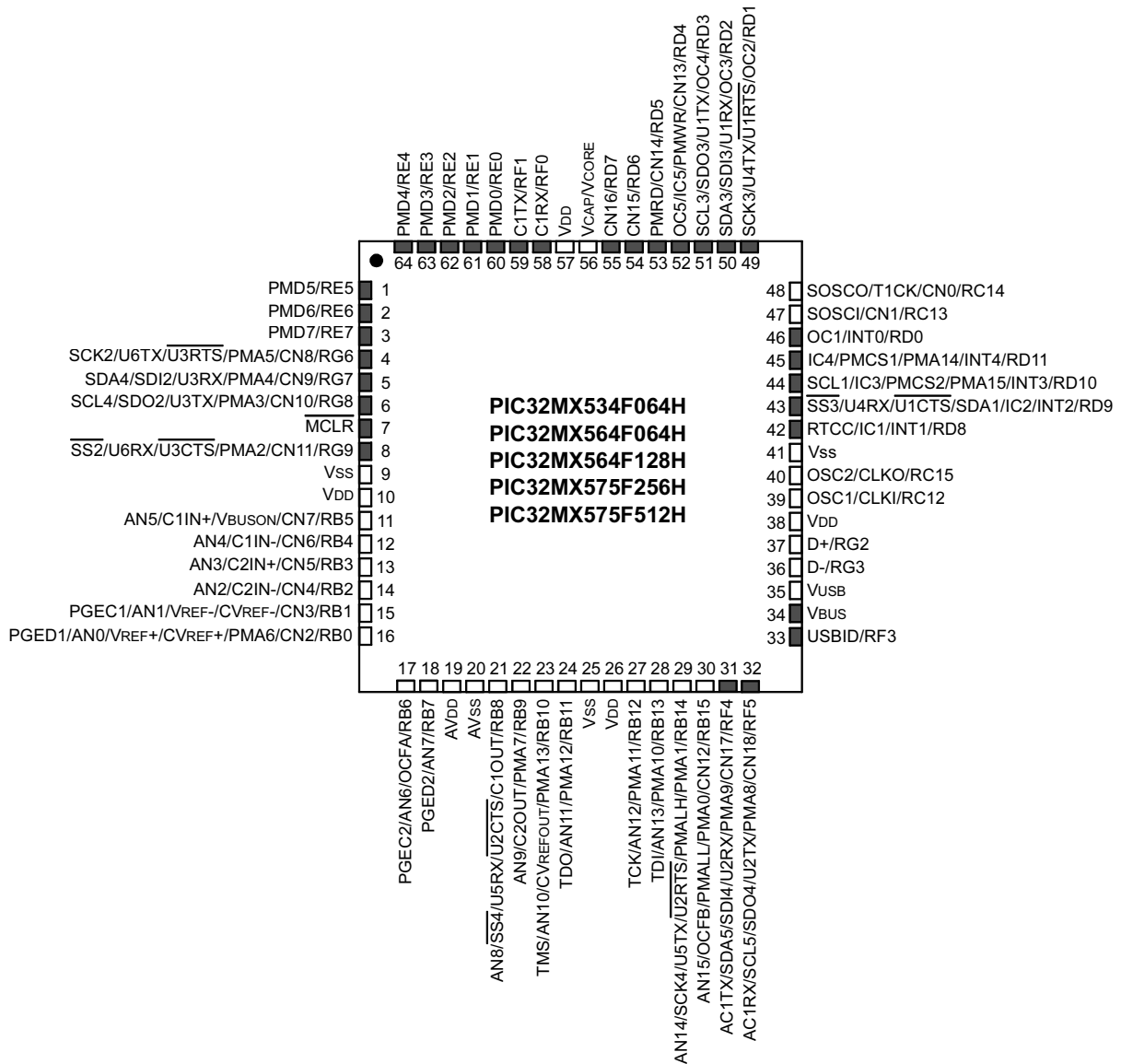

Note 1: The metal plane at the bottom of the device is not connected to any pins and is recommended to be connected to Vss externally.

PIC32MX5XX/6XX/7XX

Pin Diagrams (Continued)

64-Pin QFN⁽¹⁾

■ = Pins are up to 5V tolerant

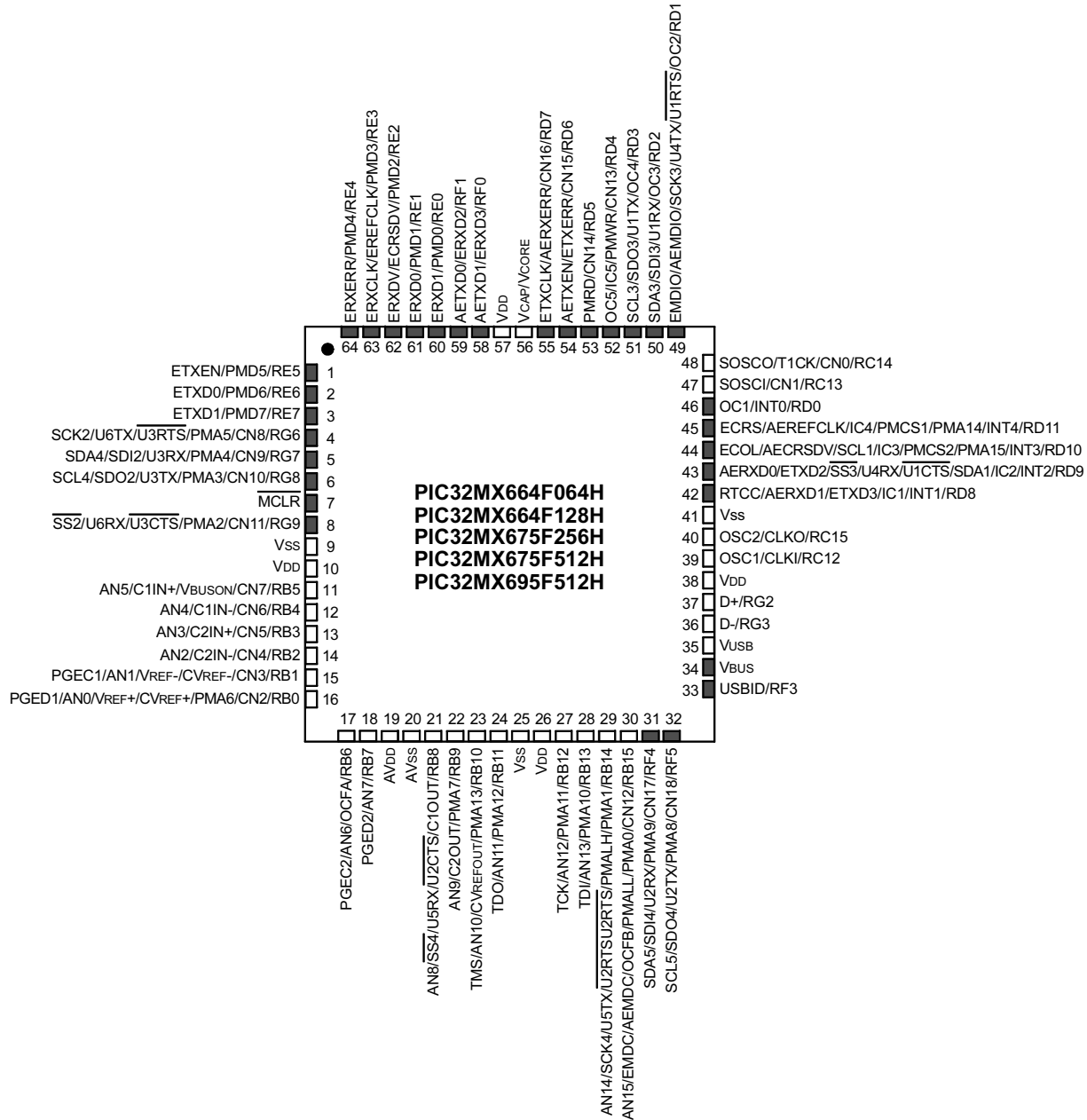

Note 1: The metal plane at the bottom of the device is not connected to any pins and is recommended to be connected to Vss externally.

Pin Diagrams (Continued)

64-Pin QFN⁽¹⁾

■ = Pins are up to 5V tolerant

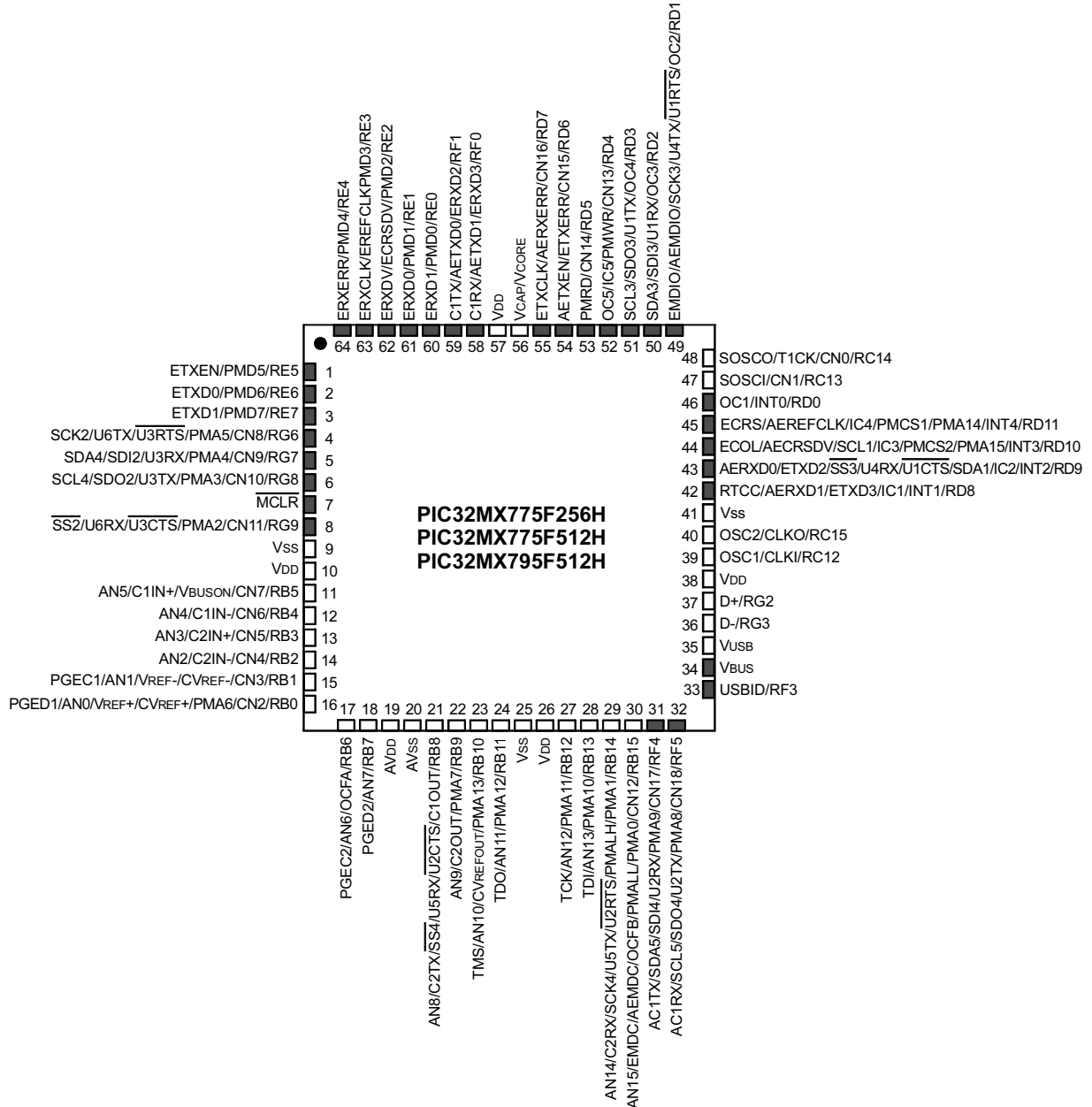

Note 1: The metal plane at the bottom of the device is not connected to any pins and is recommended to be connected to Vss externally.

PIC32MX5XX/6XX/7XX

Pin Diagrams (Continued)

64-Pin QFN⁽¹⁾

■ = Pins are up to 5V tolerant

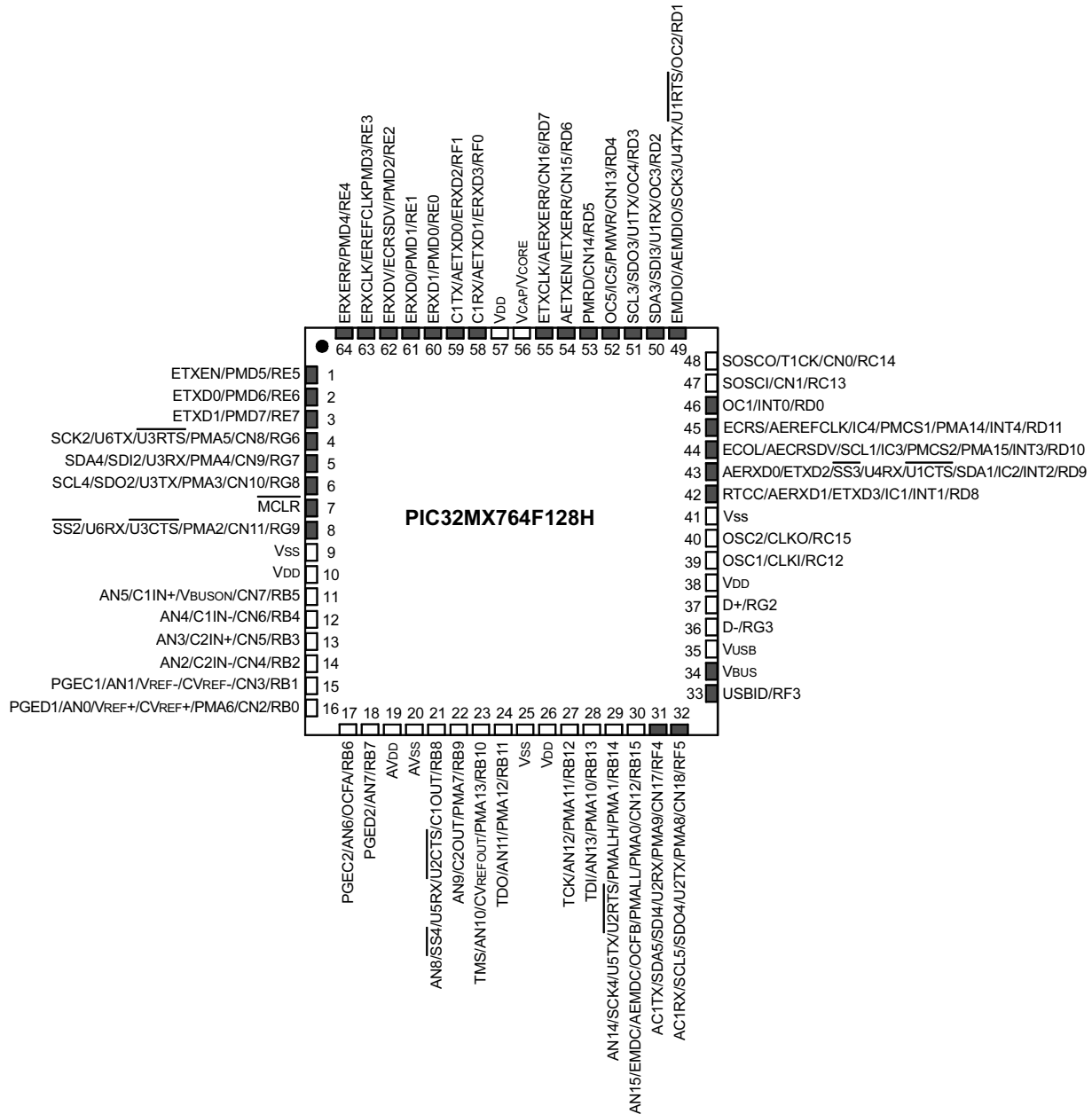

Note 1: The metal plane at the bottom of the device is not connected to any pins and is recommended to be connected to Vss externally.

Pin Diagrams (Continued)

64-Pin TQFP

■ = Pins are up to 5V tolerant

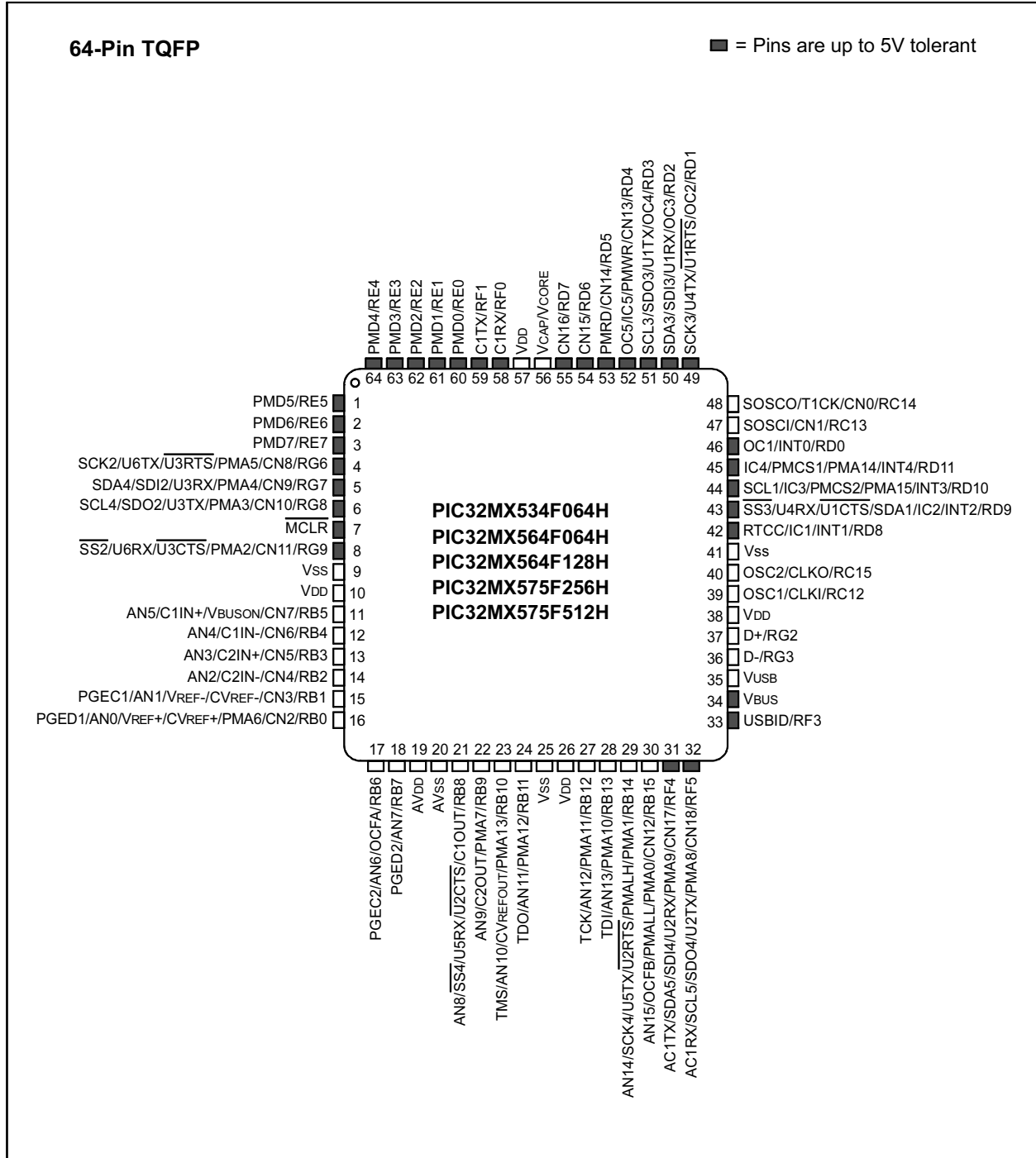

PIC32MX5XX/6XX/7XX

Pin Diagrams (Continued)

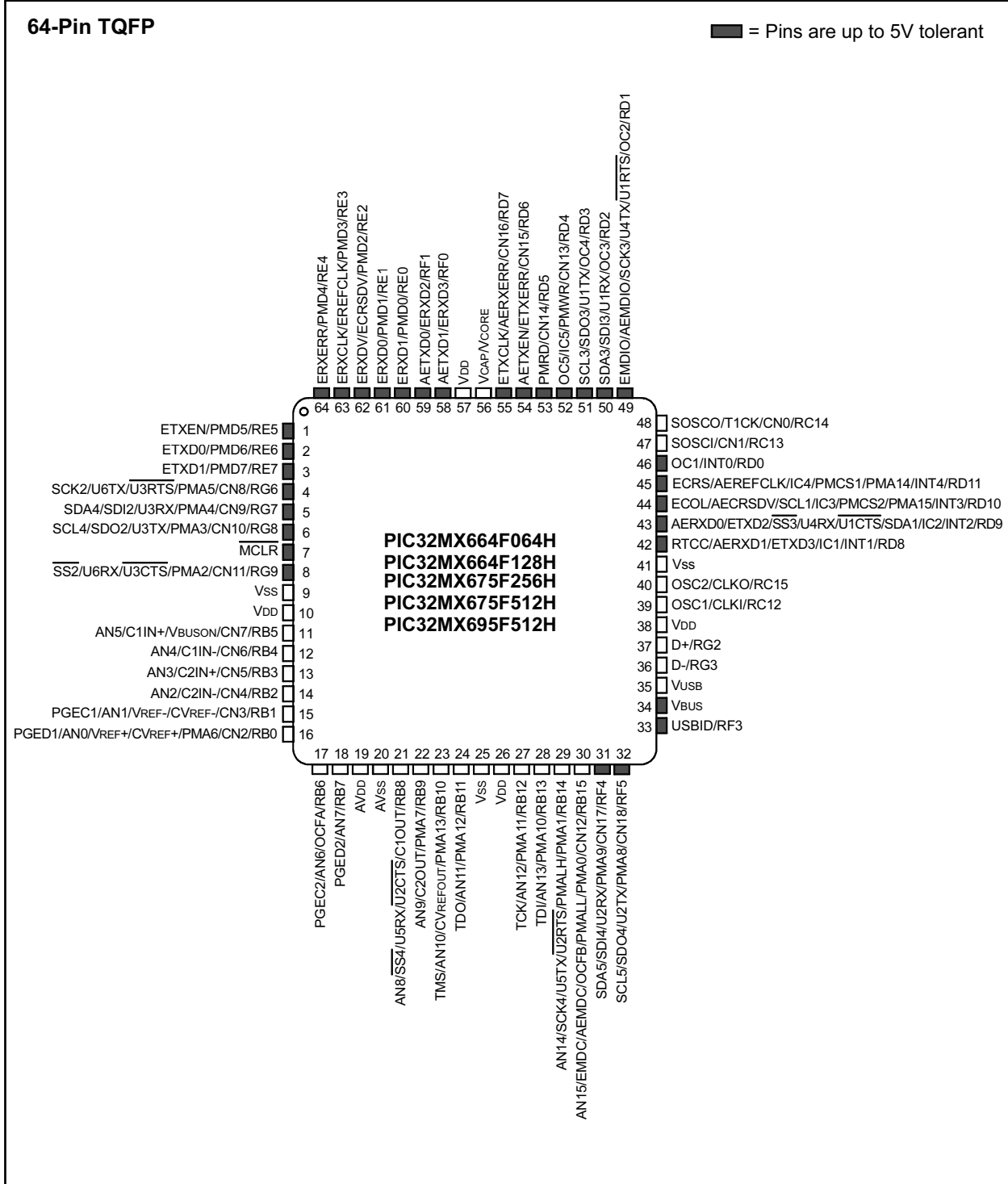

Pin Diagrams (Continued)

64-Pin TQFP

■ = Pins are up to 5V tolerant

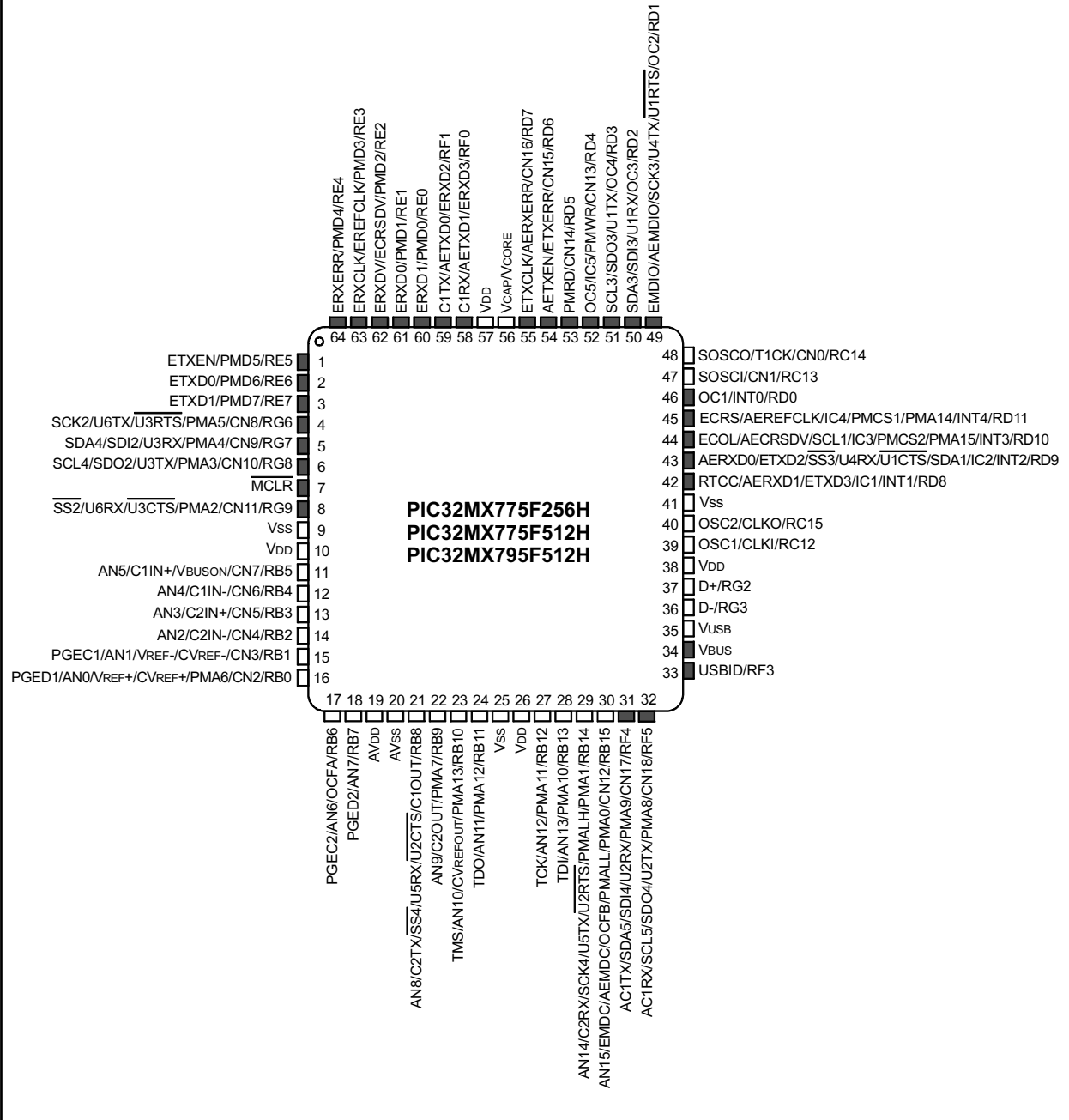

PIC32MX5XX/6XX/7XX

Pin Diagrams (Continued)

64-Pin TQFP

■ = Pins are up to 5V tolerant

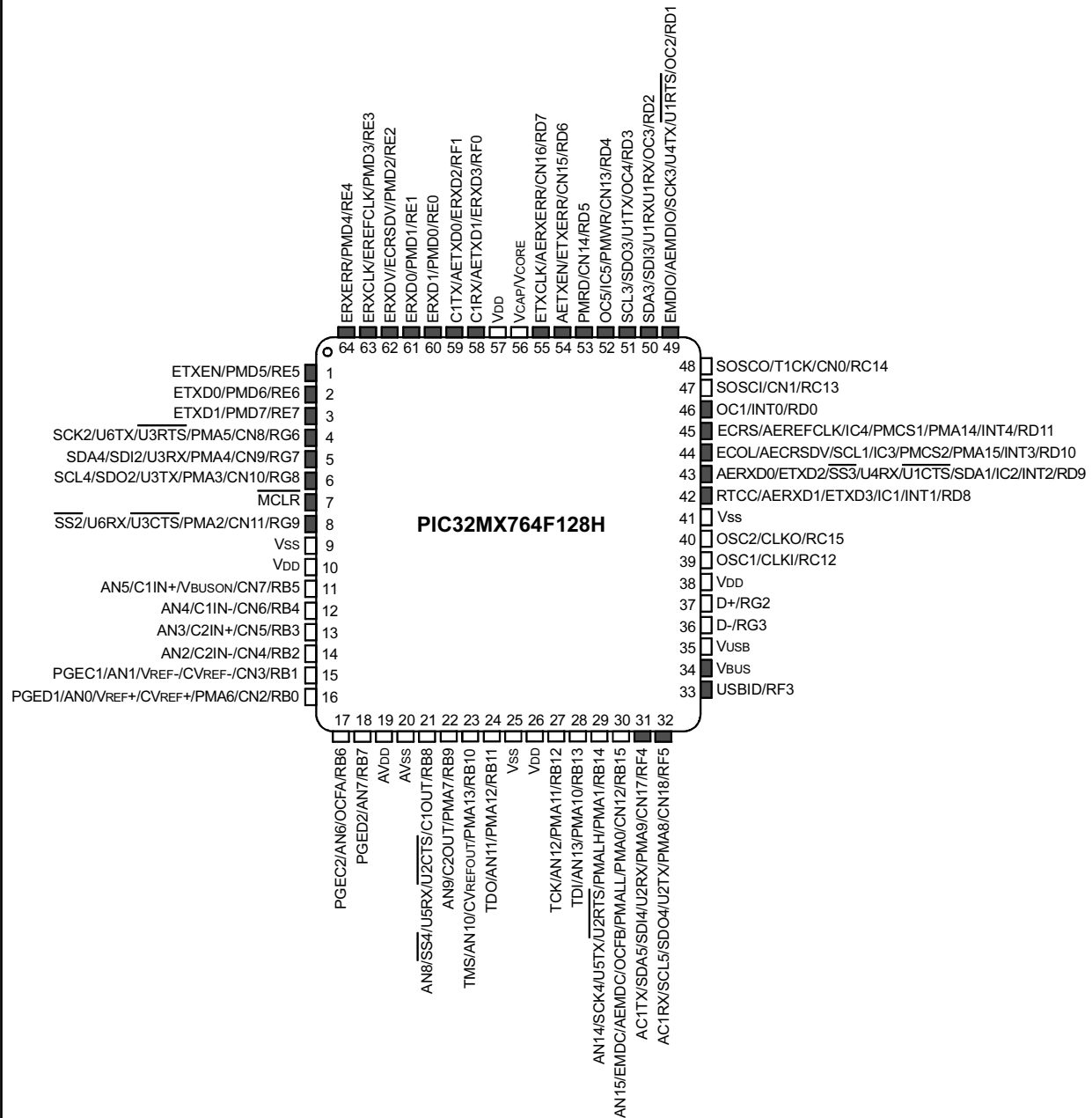

Pin Diagrams (Continued)

100-Pin TQFP

 = Pins are up to 5V tolerant

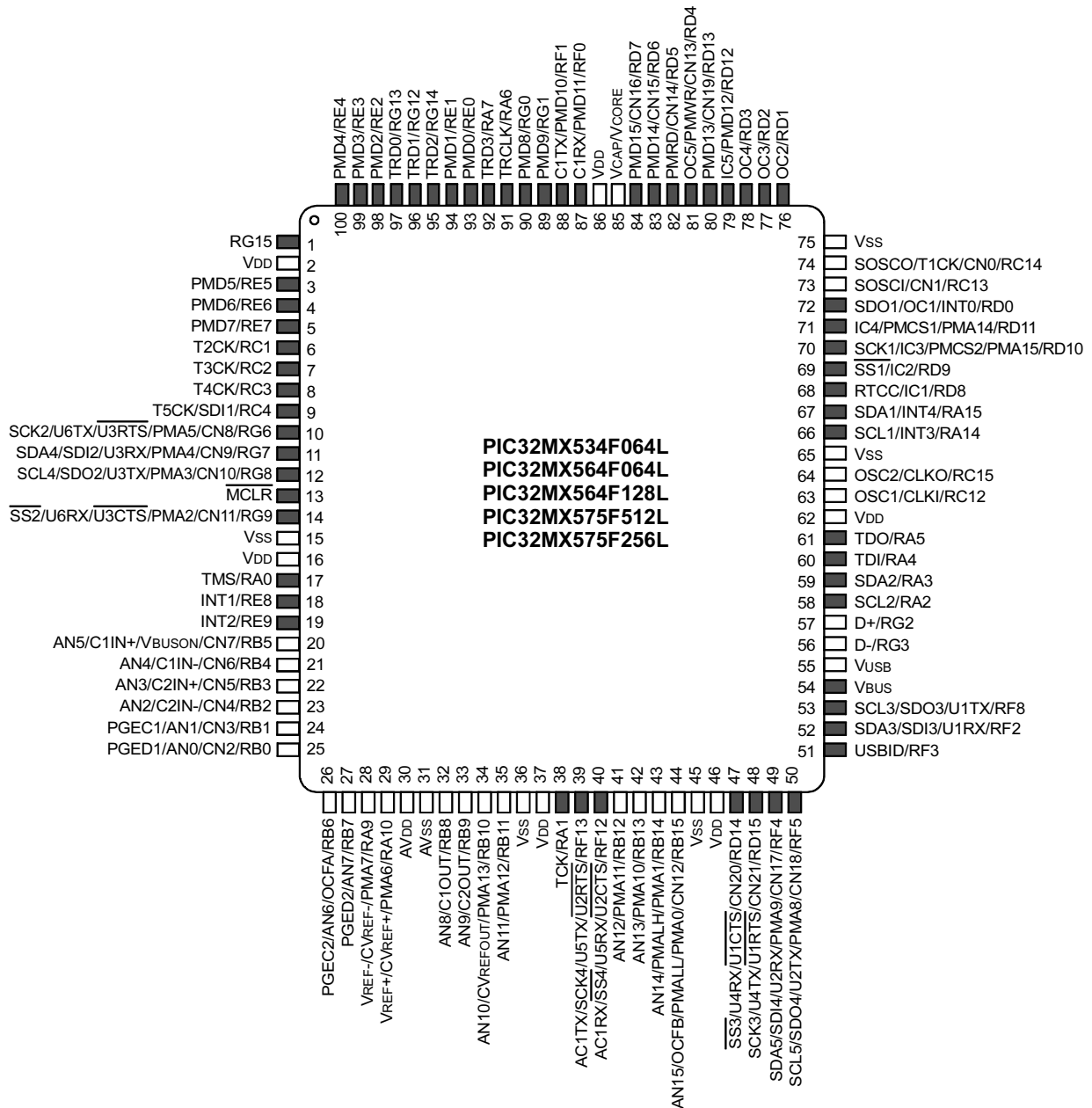

Pin Diagrams (Continued)

100-Pin TQFP

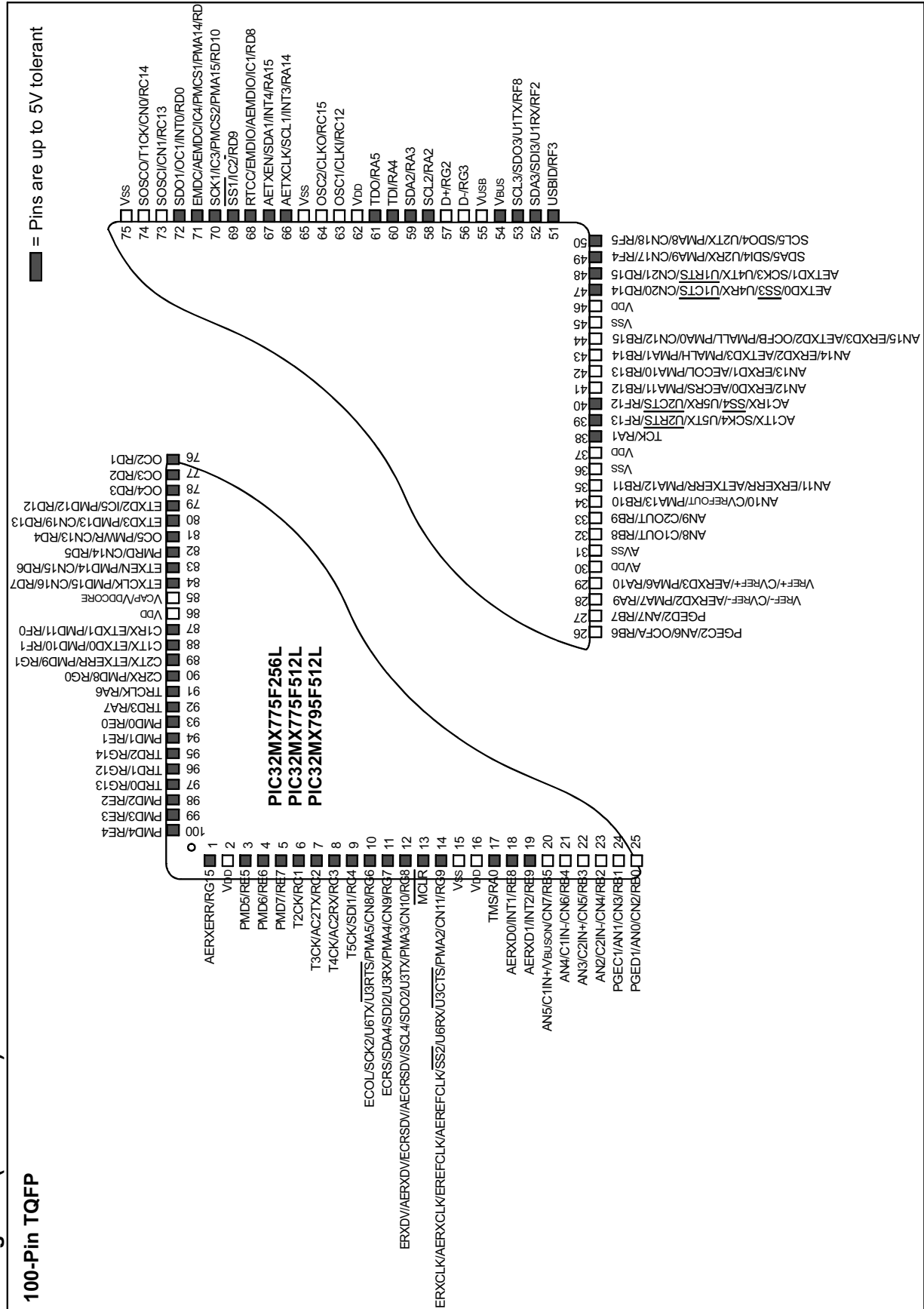

Pin Diagrams (Continued)

100-Pin TQFP

■ = Pins are up to 5V tolerant

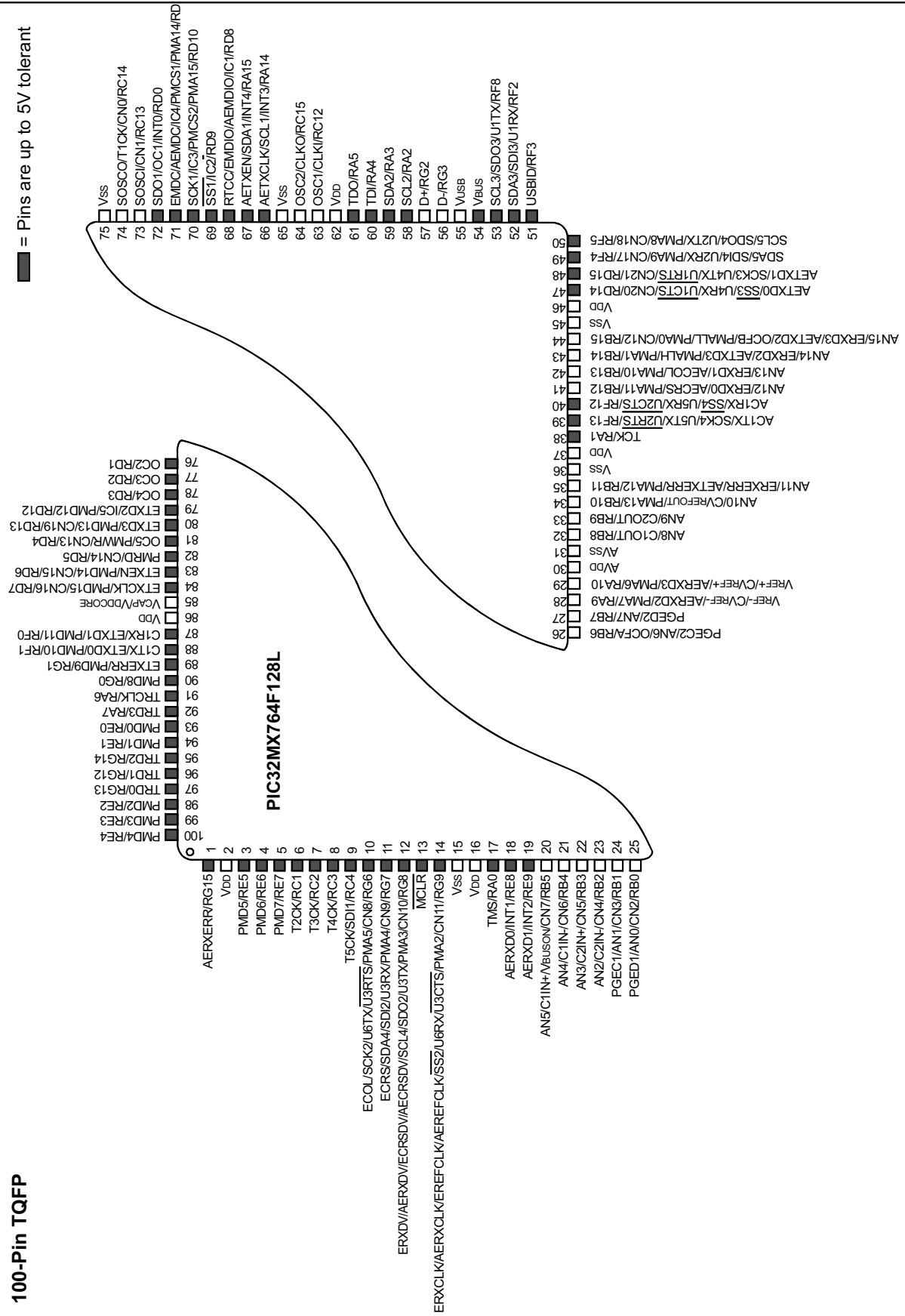

Pin Diagrams (Continued)

121-Pin XBGA⁽¹⁾

● = Pins are up to 5V tolerant

PIC32MX534F064L
 PIC32MX564F064L
 PIC32MX664F064L
 PIC32MX564F128L
 PIC32MX664F128L
 PIC32MX764F128L
 PIC32MX575F256L
 PIC32MX675F256L
 PIC32MX775F256L
 PIC32MX575F512L
 PIC32MX675F512L
 PIC32MX695F512L
 PIC32MX775F512L
 PIC32MX795F512L

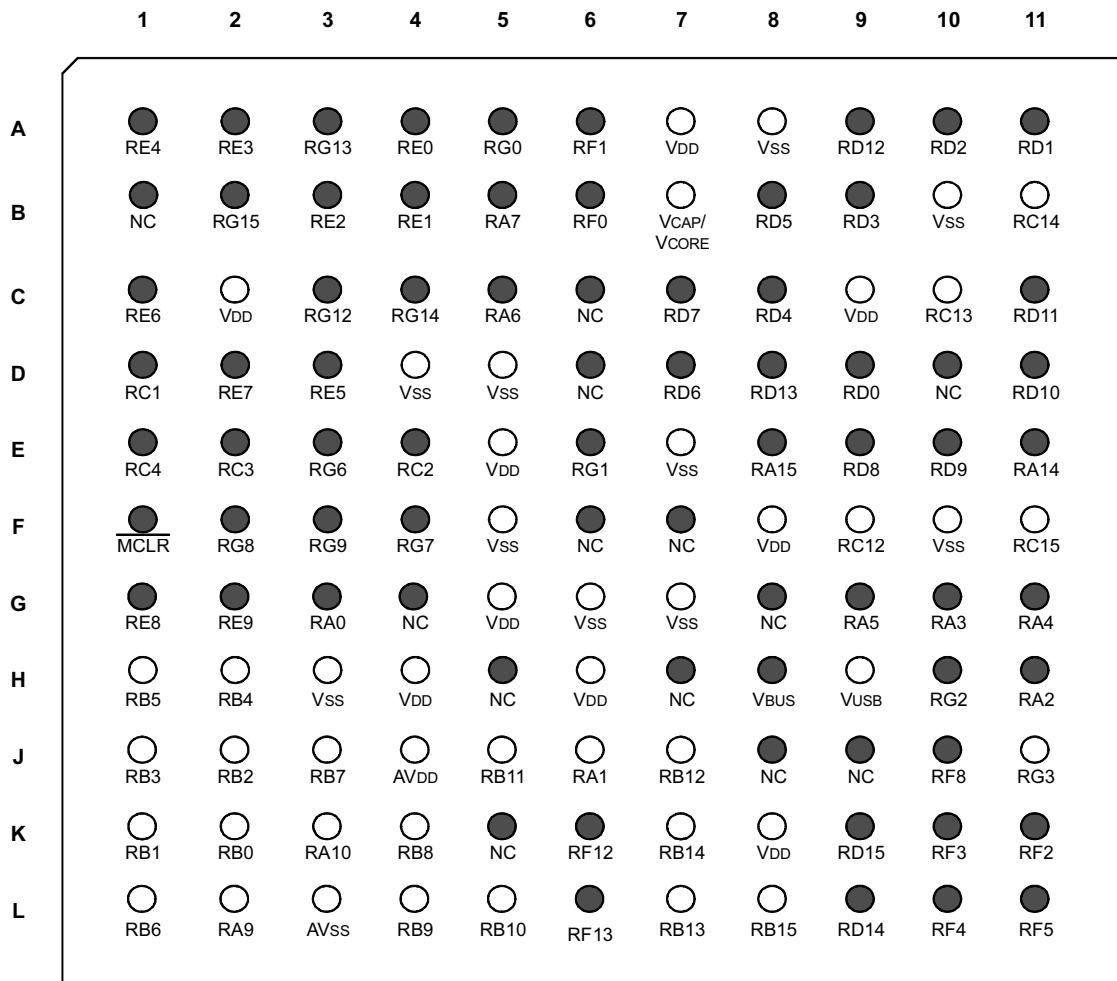

Note 1: Refer to [Table 4](#), [Table 5](#) and [Table 6](#) for full pin names.

PIC32MX5XX/6XX/7XX

TABLE 4: PIN NAMES: PIC32MX534F064L, PIC32MX564F064L, PIC32MX564F128L, PIC32MX575F256L AND PIC32MX575F512L DEVICES

Pin Number	Full Pin Name
A1	PMD4/RE4
A2	PMD3/RE3
A3	TRD0/RG13
A4	PMD0/RE0
A5	PMD8/RG0
A6	C1TX/PMD10/RF1
A7	VDD
A8	VSS
A9	IC5/PMD12/RD12
A10	OC3/RD2
A11	OC2/RD1
B1	No Connect (NC)
B2	RG15
B3	PMD2/RE2
B4	PMD1/RE1
B5	TRD3/RA7
B6	C1RX/PMD11/RF0
B7	VCAP/VCORE
B8	PMRD/CN14/RD5
B9	OC4/RD3
B10	VSS
B11	SOSCO/T1CK/CN0/RC14
C1	PMD6/RE6
C2	VDD
C3	TRD1/RG12
C4	TRD2/RG14
C5	TRCLK/RA6
C6	No Connect (NC)
C7	PMD15/CN16/RD7
C8	OC5/PMWR/CN13/RD4
C9	VDD
C10	SOSCI/CN1/RC13
C11	IC4/PMCS1/PMA14/RD11
D1	T2CK/RC1
D2	PMD7/RE7
D3	PMD5/RE5
D4	VSS
D5	VSS
D6	No Connect (NC)
D7	PMD14/CN15/RD6
D8	PMD13/CN19/RD13
D9	SDO1/OC1/INT0/RD0
D10	No Connect (NC)
D11	SCK1/IC3/PMCS2/PMA15/RD10
E1	T5CK/SD11/RC4
E2	T4CK/RC3
E3	SCK2/U6TXU6TX/U3RTS/PMA5/CN8/RG6
E4	T3CK/RC2
E5	VDD
E6	PMD9/RG1
E7	VSS

Pin Number	Full Pin Name
E8	SDA1/INT4/RA15
E9	RTCC/IC1/RD8
E10	SS1/IC2/RD9
E11	SCL1/INT3/RA14
F1	MCLR
F2	SCL4/SDO2/U3TX/PMA3/CN10/RG8
F3	SS2/U6RX/U3CTS/PMA2/CN11/RG9
F4	SDA4/SDI2/U3RX/PMA4/CN9/RG7
F5	VSS
F6	No Connect (NC)
F7	No Connect (NC)
F8	VDD
F9	OSC1/CLKI/RC12
F10	VSS
F11	OSC2/CLKO/RC15
G1	INT1/RE8
G2	INT2/RE9
G3	TMS/RA0
G4	No Connect (NC)
G5	VDD
G6	VSS
G7	VSS
G8	No Connect (NC)
G9	TDO/RA5
G10	SDA2/RA3
G11	TDI/RA4
H1	AN5/C1IN+/VBUSON/CN7/RB5
H2	AN4/C1IN-/CN6/RB4
H3	VSS
H4	VDD
H5	No Connect (NC)
H6	VDD
H7	No Connect (NC)
H8	VBUS
H9	VUSB
H10	D+/RG2
H11	SCL2/RA2
J1	AN3/C2IN+/CN5/RB3
J2	AN2/C2IN-/CN4/RB2
J3	PGED2/AN7/RB7
J4	AVDD
J5	AN11/PMA12/RB11
J6	TCK/RA1
J7	AN12/PMA11/RB12
J8	No Connect (NC)
J9	No Connect (NC)
J10	SCL3/SDO3/U1TX/RF8
J11	D-/RG3
K1	PGEC1/AN1/CN3/RB1
K2	PGED1/AN0/CN2/RB0
K3	VREF+/CVREF+/PMA6/RA10

TABLE 4: PIN NAMES: PIC32MX534F064L, PIC32MX564F064L, PIC32MX564F128L, PIC32MX575F256L AND PIC32MX575F512L DEVICES (CONTINUED)

Pin Number	Full Pin Name
K4	AN8/C1OUT/RB8
K5	No Connect (NC)
K6	AC1RX/SS4/U5RX/U2CTS/RF12
K7	AN14/PMALH/PMA1/RB14
K8	VDD
K9	SCK3/U4TX/U1RTS/CN21/RD15
K10	USBID/RF3
K11	SDA3/SDI3/U1RX/RF2
L1	PGEC2/AN6/OCFA/RB6
L2	VREF-/CVREF-/PMA7/RA9

Pin Number	Full Pin Name
L3	AVSS
L4	AN9/C2OUT/RB9
L5	AN10/CVREFOUT/PMA13/RB10
L6	AC1TX/SCK4/U5TX/U2RTS/RF13
L7	AN13/PMA10/RB13
L8	AN15/OCFB/PMALL/PMA0/CN12/RB15
L9	SS3/U4RX/U1CTS/CN20/RD14
L10	SDA5/SDI4/U2RX/PMA9/CN17/RF4
L11	SCL5/SDO4/U2TX/PMA8/CN18/RF5

PIC32MX5XX/6XX/7XX

TABLE 5: PIN NAMES: PIC32MX664F064L, PIC32MX664F128L, PIC32MX675F256L, PIC32MX675F512L AND PIC32MX695F512L DEVICES

Pin Number	Full Pin Name
A1	PMD4/RE4
A2	PMD3/RE3
A3	TRD0/RG13
A4	PMD0/RE0
A5	PMD8/RG0
A6	ETXD0/PMD10/RF1
A7	VDD
A8	VSS
A9	ETXD2/IC5/PMD12/RD12
A10	OC3/RD2
A11	OC2/RD1
B1	No Connect (NC)
B2	AERXERR/RG15
B3	PMD2/RE2
B4	PMD1/RE1
B5	TRD3/RA7
B6	ETXD1/PMD11/RF0
B7	VCAP/VCORE
B8	PMRD/CN14/RD5
B9	OC4/RD3
B10	VSS
B11	SOSCO/T1CK/CN0/RC14
C1	PMD6/RE6
C2	VDD
C3	TRD1/RG12
C4	TRD2/RG14
C5	TRCLK/RA6
C6	No Connect (NC)
C7	ETXCLK/PMD15/CN16/RD7
C8	OC5/PMWR/CN13/RD4
C9	VDD
C10	SOSCI/CN1/RC13
C11	EMDC/AEMDC/IC4/PMCS1/PMA14/RD11
D1	T2CK/RC1
D2	PMD7/RE7
D3	PMD5/RE5
D4	VSS
D5	VSS
D6	No Connect (NC)
D7	ETXEN/PMD14/CN15/RD6
D8	ETXD3/PMD13/CN19/RD13
D9	SDO1/OC1/INT0/RD0
D10	No Connect (NC)
D11	SCK1/IC3/PMCS2/PMA15/RD10
E1	T5CK/SD11/RC4
E2	T4CK/RC3
E3	ECOL/SCK2/U6TX/U3RTS/PMA5/CN8/RG6
E4	T3CK/RC2
E5	VDD
E6	ETXERR/PMD9/RG1
E7	VSS

Pin Number	Full Pin Name
E8	AETXEN/SDA1/INT4/RA15
E9	RTCC/EMDIO/AEMDIO/IC1/RD8
E10	SS1/IC2/RD9
E11	AETXCLK/SCL1/INT3/RA14
F1	MCLR
F2	ERXDV/AERXDV/ECRSDV/AECRSDV//SCL4/SDO2/ U3TX/PMA3/CN10/RG8
F3	ERXCLK/AERXCLK/EREFCLK/AEREFCLK//SS2/U6RX/ U3CTS/PMA2/CN11/RG9
F4	ECRS/SDA4/SDI2/U3RX/PMA4/CN9/RG7
F5	VSS
F6	No Connect (NC)
F7	No Connect (NC)
F8	VDD
F9	OSC1/CLKI/RC12
F10	VSS
F11	OSC2/CLKO/RC15
G1	AERXD0/INT1/RE8
G2	AERXD1/INT2/RE9
G3	TMS/RA0
G4	No Connect (NC)
G5	VDD
G6	VSS
G7	VSS
G8	No Connect (NC)
G9	TDO/RA5
G10	SDA2/RA3
G11	TDI/RA4
H1	AN5/C1IN+/VBUSON/CN7/RB5
H2	AN4/C1IN-/CN6/RB4
H3	VSS
H4	VDD
H5	No Connect (NC)
H6	VDD
H7	No Connect (NC)
H8	VBUS
H9	VUSB
H10	D+/RG2
H11	SCL2/RA2
J1	AN3/C2IN+/CN5/RB3
J2	AN2/C2IN-/CN4/RB2
J3	PGED2/AN7/RB7
J4	AVDD
J5	AN11/ERXERR/AETXERR/PMA12/RB11
J6	TCK/RA1
J7	AN12/ERXD0/AECRS/PMA11/RB12
J8	No Connect (NC)
J9	No Connect (NC)
J10	SCL3/SDO3/U1TX/RF8
J11	D-/RG3
K1	PGEC1/AN1/CN3/RB1
K2	PGED1/AN0/CN2/RB0
K3	VREF+/CVREF+/AERXD3/PMA6/RA10

TABLE 5: PIN NAMES: PIC32MX664F064L, PIC32MX664F128L, PIC32MX675F256L, PIC32MX675F512L AND PIC32MX695F512L DEVICES (CONTINUED)

Pin Number	Full Pin Name
K4	AN8/C1OUT/RB8
K5	No Connect (NC)
K6	SS4/U5RX/U2CTS/RF12
K7	AN14/ERXD2/AETXD3/PMALH/PMA1/RB14
K8	VDD
K9	AETXD1/SCK3/U4TX/U1RTS/CN21/RD15
K10	USBID/RF3
K11	SDA3/SDI3/U1RX/RF2
L1	PGEC2/AN6/OCFA/RB6
L2	VREF-JVREF-/AERXD2/PMA7/RA9

Pin Number	Full Pin Name
L3	AVss
L4	AN9/C2OUT/RB9
L5	AN10/CVREFOUT/PMA13/RB10
L6	SCK4/U5TX/U2RTS/RF13
L7	AN13/ERXD1/AECOL/PMA10/RB13
L8	AN15/ERXD3/AETXD2/OCFB/PMALL/PMA0/CN12/RB15
L9	AETXD0/SS3/U4RX/U1CTS/CN20/RD14
L10	SDA5/SDI4/U2RX/PMA9/CN17/RF4
L11	SCL5/SDO4/U2TX/PMA8/CN18/RF5

PIC32MX5XX/6XX/7XX

TABLE 6: PIN NAMES: PIC32MX775F256L, PIC32MX775F512L AND PIC32MX795F512L DEVICES

Pin Number	Full Pin Name
A1	PMD4/RE4
A2	PMD3/RE3
A3	TRD0/RG13
A4	PMD0/RE0
A5	C2RX/PMD8/RG0
A6	C1TX/ETXD0/PMD10/RF1
A7	Vdd
A8	Vss
A9	ETXD2/IC5/PMD12/RD12
A10	OC3/RD2
A11	OC2/RD1
B1	No Connect (NC)
B2	AERXERR/RG15
B3	PMD2/RE2
B4	PMD1/RE1
B5	TRD3/RA7
B6	C1RX/ETXD1/PMD11/RF0
B7	VCAP/VCORE
B8	PMRD/CN14/RD5
B9	OC4/RD3
B10	Vss
B11	SOSCO/T1CK/CN0/RC14
C1	PMD6/RE6
C2	Vdd
C3	TRD1/RG12
C4	TRD2/RG14
C5	TRCLK/RA6
C6	No Connect (NC)
C7	ETXCLK/PMD15/CN16/RD7
C8	OC5/PMWR/CN13/RD4
C9	Vdd
C10	SOSCI/CN1/RC13
C11	EMDC/AEMDC/IC4/PMCS1/PMA14/RD11
D1	T2CK/RC1
D2	PMD7/RE7
D3	PMD5/RE5
D4	Vss
D5	Vss
D6	No Connect (NC)
D7	ETXEN/PMD14/CN15/RD6
D8	ETXD3/PMD13/CN19/RD13
D9	SDO1/OC1/INT0/RD0
D10	No Connect (NC)
D11	SCK1/IC3/PMCS2/PMA15/RD10
E1	T5CK/SDI1/RC4
E2	T4CK/AC2RX/RC3
E3	ECOL/SCK2/U6TX/U3RTS/PMA5/CN8/RG6
E4	T3CK/AC2TX/RC2
E5	Vdd
E6	C2TX/ETXERR/PMD9/RG1
E7	Vss

Pin Number	Full Pin Name
E8	AETXEN/SDA1/INT4/RA15
E9	RTCC/EMDIO/AEMDIO/IC1/RD8
E10	SS1/IC2/RD9
E11	AETXCLK/SCL1/INT3/RA14
F1	MCLR
F2	ERXDV/AERXDV/ECRSDV/AECRSDV/SCL4/SDO2/ U3TX/PMA3/CN10/RG8
F3	ERXCLK/AERXCLK/EREFCLK/AEREFCLK/SS2/U6RX/ U3CTS/PMA2/CN11/RG9
F4	ECRS/SDA4/SDI2/U3RX/PMA4/CN9/RG7
F5	Vss
F6	No Connect (NC)
F7	No Connect (NC)
F8	Vdd
F9	OSC1/CLKI/RC12
F10	Vss
F11	OSC2/CLKO/RC15
G1	AERXD0/INT1/RE8
G2	AERXD1/INT2/RE9
G3	TMS/RA0
G4	No Connect (NC)
G5	Vdd
G6	Vss
G7	Vss
G8	No Connect (NC)
G9	TDO/RA5
G10	SDA2/RA3
G11	TDI/RA4
H1	AN5/C1IN+/VBUSON/CN7/RB5
H2	AN4/C1IN-/CN6/RB4
H3	Vss
H4	Vdd
H5	No Connect (NC)
H6	Vdd
H7	No Connect (NC)
H8	Vbus
H9	Vusb
H10	D+/RG2
H11	SCL2/RA2
J1	AN3/C2IN+/CN5/RB3
J2	AN2/C2IN-/CN4/RB2
J3	PGED2/AN7/RB7
J4	AVdd
J5	AN11/ERXERR/AETXERR/PMA12/RB11
J6	TCK/RA1
J7	AN12/ERXD0/AECRS/PMA11/RB12
J8	No Connect (NC)
J9	No Connect (NC)
J10	SCL3/SDO3/U1TX/RF8
J11	D-/RG3
K1	PGEC1/AN1/CN3/RB1
K2	PGED1/AN0/CN2/RB0
K3	VREF+/CVREF+/AERXD3/PMA6/RA10

TABLE 6: PIN NAMES: PIC32MX775F256L, PIC32MX775F512L AND PIC32MX795F512L DEVICES (CONTINUED)

Pin Number	Full Pin Name
K4	AN8/C1OUT/RB8
K5	No Connect (NC)
K6	AC1RX/SS4/U5RX/U2CTS/RF12
K7	AN14/ERXD2/AETXD3/PMALH/PMA1/RB14
K8	VDD
K9	AETXD1/SCK3/U4TX/U1RTS/CN21/RD15
K10	USBID/RF3
K11	SDA3/SDI3/U1RX/RF2
L1	PGEC2/AN6/OCFA/RB6
L2	VREF-/CVREF-/AERXD2/PMA7/RA9

Pin Number	Full Pin Name
L3	AVss
L4	AN9/C2OUT/RB9
L5	AN10/CVREFOUT/PMA13/RB10
L6	AC1TX/SCK4/U5TX/U2RTS/RF13
L7	AN13/ERXD1/AECOL/PMA10/RB13
L8	AN15/ERXD3/AETXD2/OCFB/PMALL/PMA0/CN12/RB15
L9	AETXD0/SS3/U4RX/U1CTS/CN20/RD14
L10	SDA5/SDI4/U2RX/PMA9/CN17/RF4
L11	SCL5/SDO4/U2TX/PMA8/CN18/RF5

PIC32MX5XX/6XX/7XX

TABLE 7: PIN NAME: PIC32MX764F128L DEVICE

Pin Number	Full Pin Name
A1	PMD4/RE4
A2	PMD3/RE3
A3	TRD0/RG13
A4	PMD0/RE0
A5	PMD8/RG0
A6	C1TX/ETXD0/PMD10/RF1
A7	Vdd
A8	Vss
A9	ETXD2/IC5/PMD12/RD12
A10	OC3/RD2
A11	OC2/RD1
B1	No Connect (NC)
B2	AERXERR/RG15
B3	PMD2/RE2
B4	PMD1/RE1
B5	TRD3/RA7
B6	C1RX/ETXD1/PMD11/RF0
B7	VCAP/VCORE
B8	PMRD/CN14/RD5
B9	OC4/RD3
B10	Vss
B11	SOSCO/T1CK/CN0/RC14
C1	PMD6/RE6
C2	Vdd
C3	TRD1/RG12
C4	TRD2/RG14
C5	TRCLK/RA6
C6	No Connect (NC)
C7	ETXCLK/PMD15/CN16/RD7
C8	OC5/PMWR/CN13/RD4
C9	Vdd
C10	SOSCI/CN1/RC13
C11	EMDC/AEMDC/IC4/PMCS1/PMA14/RD11
D1	T2CK/RC1
D2	PMD7/RE7
D3	PMD5/RE5
D4	Vss
D5	Vss
D6	No Connect (NC)
D7	ETXEN/PMD14/CN15/RD6
D8	ETXD3/PMD13/CN19/RD13
D9	SDO1/OC1/INT0/RD0
D10	No Connect (NC)
D11	SCK1/IC3/PMCS2/PMA15/RD10
E1	T5CK/SDI1/RC4
E2	T4CK/RC3
E3	ECOL/SCK2/U6TX/U3RTS/PMA5/CN8/RG6
E4	T3CK/RC2
E5	Vdd
E6	ETXERR/PMD9/RG1
E7	Vss

Pin Number	Full Pin Name
E8	AETXEN/SDA1/INT4/RA15
E9	RTCC/EMDIO/AEMDIO/IC1/RD8
E10	SS1/IC2/RD9
E11	AETXCLK/SCL1/INT3/RA14
F1	MCLR
F2	ERXDV/AERXDV/ECRS/SDV/AECRS/SDV/SCL4/SDO2/ U3TX/PMA3/CN10/RG8
F3	ERXCLK/AERXCLK/EREFCLK/AEREFCLK/SS2/U6RX/ U3CTS/PMA2/CN11/RG9
F4	ECRS/SDA4/SDI2/U3RX/PMA4/CN9/RG7
F5	Vss
F6	No Connect (NC)
F7	No Connect (NC)
F8	Vdd
F9	OSC1/CLKI/RC12
F10	Vss
F11	OSC2/CLKO/RC15
G1	AERXD0/INT1/RE8
G2	AERXD1/INT2/RE9
G3	TMS/RA0
G4	No Connect (NC)
G5	Vdd
G6	Vss
G7	Vss
G8	No Connect (NC)
G9	TDO/RA5
G10	SDA2/RA3
G11	TDI/RA4
H1	AN5/C1IN+/VBUSON/CN7/RB5
H2	AN4/C1IN-/CN6/RB4
H3	Vss
H4	Vdd
H5	No Connect (NC)
H6	Vdd
H7	No Connect (NC)
H8	Vbus
H9	Vusb
H10	D+/RG2
H11	SCL2/RA2
J1	AN3/C2IN+/CN5/RB3
J2	AN2/C2IN-/CN4/RB2
J3	PGED2/AN7/RB7
J4	AVdd
J5	AN11/ERXERR/AETXERR/PMA12/RB11
J6	TCK/RA1
J7	AN12/ERXD0/AECRS/PMA11/RB12
J8	No Connect (NC)
J9	No Connect (NC)
J10	SCL3/SDO3/U1TX/RF8
J11	D-/RG3
K1	PGEC1/AN1/CN3/RB1
K2	PGED1/AN0/CN2/RB0
K3	VREF+/CVREF+/AERXD3/PMA6/RA10

TABLE 7: PIN NAME: PIC32MX764F128L DEVICE (CONTINUED)

Pin Number	Full Pin Name
K4	AN8/C1OUT/RB8
K5	No Connect (NC)
K6	AC1RX/SS4/U5RX/U2CTS/RF12
K7	AN14/ERXD2/AETXD3/PMALH/PMA1/RB14
K8	VDD
K9	AETXD1/SCK3/U4TX/U1RTS/CN21/RD15
K10	USBID/RF3
K11	SDA3/SDI3/U1RX/RF2
L1	PGEC2/AN6/OCFA/RB6
L2	VREF-/CVREF-/AERXD2/PMA7/RA9

Pin Number	Full Pin Name
L3	AVSS
L4	AN9/C2OUT/RB9
L5	AN10/CVREFOUT/PMA13/RB10
L6	AC1TX/SCK4/U5TX/U2RTS/RF13
L7	AN13/ERXD1/AECOL/PMA10/RB13
L8	AN15/ERXD3/AETXD2/OCFB/PMALL/PMA0/CN12/RB15
L9	AETXD0/SS3/U4RX/U1CTS/CN20/RD14
L10	SDA5/SDI4/U2RX/PMA9/CN17/RF4
L11	SCL5/SDO4/U2TX/PMA8/CN18/RF5

Table of Contents

1.0	Device Overview	31
2.0	Guidelines for Getting Started with 32-bit Microcontrollers	43
3.0	CPU	49
4.0	Memory Organization	55
5.0	Flash Program Memory	117
6.0	Resets	119
7.0	Interrupt Controller	121
8.0	Oscillator Configuration	125
9.0	Prefetch Cache	127
10.0	Direct Memory Access (DMA) Controller	129
11.0	USB On-The-Go (OTG)	131
12.0	I/O Ports	133
13.0	Timer1	135
14.0	Timer2/3, Timer4/5	137
15.0	Input Capture	139
16.0	Output Compare	141
17.0	Serial Peripheral Interface (SPI)	143
18.0	Inter-Integrated Circuit™ (I ² C™)	145
19.0	Universal Asynchronous Receiver Transmitter (UART)	147
20.0	Parallel Master Port (PMP)	149
21.0	Real-Time Clock and Calendar (RTCC)	151
22.0	10-bit Analog-to-Digital Converter (ADC)	153
23.0	Controller Area Network (CAN)	155
24.0	Ethernet Controller	157
25.0	Comparator	159
26.0	Comparator Voltage Reference (CVREF)	161
27.0	Power-Saving Features	163
28.0	Special Features	165
29.0	Instruction Set	177
30.0	Development Support	179
31.0	Electrical Characteristics	183
32.0	Packaging Information	225
	The Microchip Web Site	253
	Customer Change Notification Service	253
	Customer Support	253
	Reader Response	254
	Product Identification System	255

TO OUR VALUED CUSTOMERS

It is our intention to provide our valued customers with the best documentation possible to ensure successful use of your Microchip products. To this end, we will continue to improve our publications to better suit your needs. Our publications will be refined and enhanced as new volumes and updates are introduced.

If you have any questions or comments regarding this publication, please contact the Marketing Communications Department via E-mail at docerrors@microchip.com or fax the **Reader Response Form** in the back of this data sheet to (480) 792-4150. We welcome your feedback.

Most Current Data Sheet

To obtain the most up-to-date version of this data sheet, please register at our Worldwide Web site at:

<http://www.microchip.com>

You can determine the version of a data sheet by examining its literature number found on the bottom outside corner of any page. The last character of the literature number is the version number, (e.g., DS30000A is version A of document DS30000).

Errata

An errata sheet, describing minor operational differences from the data sheet and recommended workarounds, may exist for current devices. As device/documentation issues become known to us, we will publish an errata sheet. The errata will specify the revision of silicon and revision of document to which it applies.

To determine if an errata sheet exists for a particular device, please check with one of the following:

- Microchip's Worldwide Web site; <http://www.microchip.com>
- Your local Microchip sales office (see last page)

When contacting a sales office, please specify which device, revision of silicon and data sheet (include literature number) you are using.

Customer Notification System

Register on our web site at www.microchip.com to receive the most current information on all of our products.

NOTES:

1.0 DEVICE OVERVIEW

Note 1: This data sheet summarizes the features of the PIC32MX5XX/6XX/7XX family of devices. It is not intended to be a comprehensive reference source. To complement the information in this data sheet, refer to the related section of the “PIC32 Family Reference Manual”, which is available from the Microchip web site (www.microchip.com/PIC32).

2: Some registers and associated bits described in this section may not be available on all devices. Refer to **Section 4.0 “Memory Organization”** in this data sheet for device-specific register and bit information.

This document contains device-specific information for PIC32MX5XX/6XX/7XX devices.

Figure 1-1 illustrates a general block diagram of the core and peripheral modules in the PIC32MX5XX/6XX/7XX family of devices.

Table 1-1 lists the functions of the various pins shown in the pinout diagrams.

FIGURE 1-1: BLOCK DIAGRAM^(1,2)

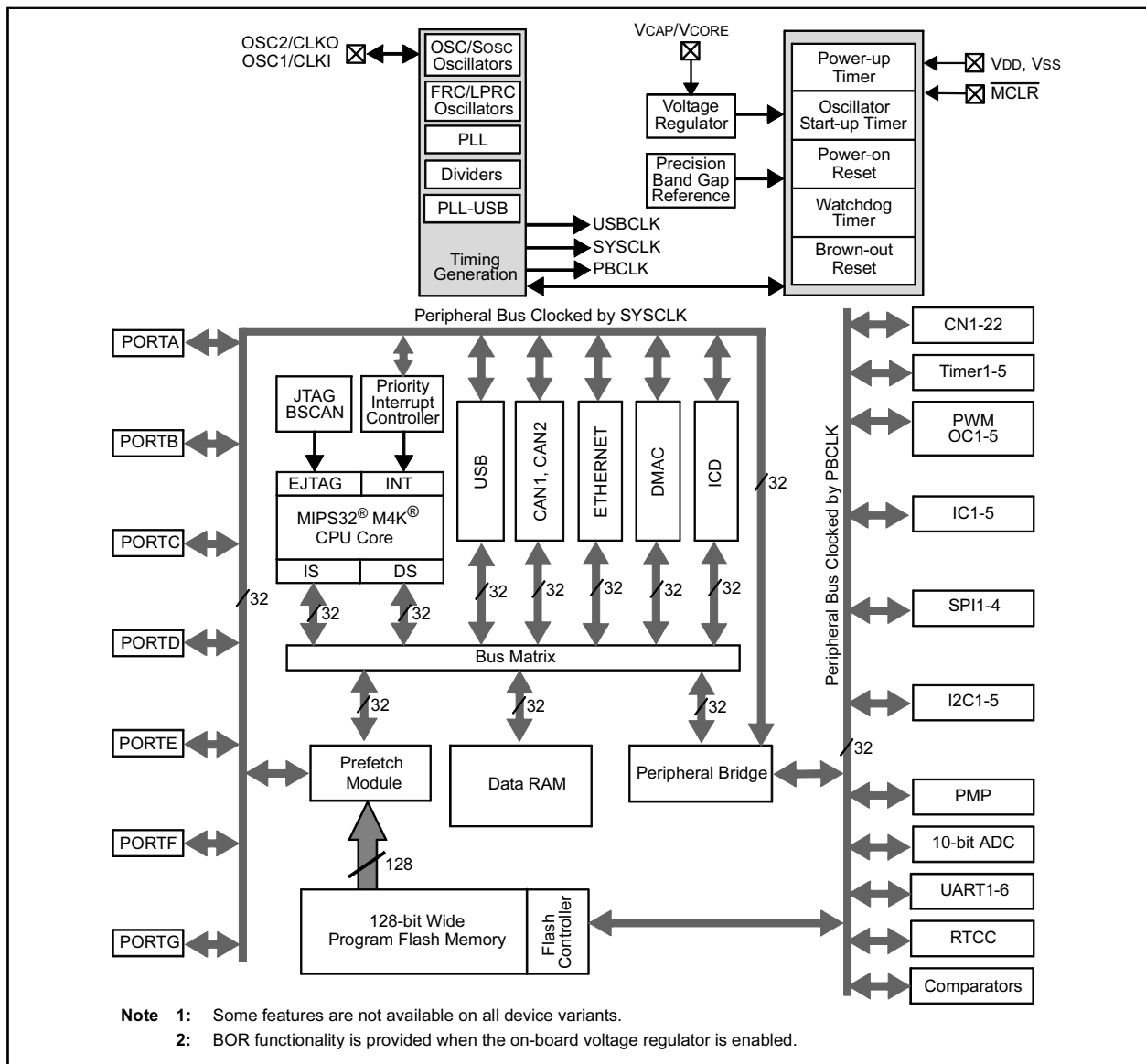

PIC32MX5XX/6XX/7XX

TABLE 1-1: PINOUT I/O DESCRIPTIONS

Pin Name	Pin Number ⁽¹⁾			Pin Type	Buffer Type	Description
	64-Pin QFN/TQFP	100-Pin TQFP	121-Pin XBGA			
AN0	16	25	K2	I	Analog	Analog input channels.
AN1	15	24	K1	I	Analog	
AN2	14	23	J2	I	Analog	
AN3	13	22	J1	I	Analog	
AN4	12	21	H2	I	Analog	
AN5	11	20	H1	I	Analog	
AN6	17	26	L1	I	Analog	
AN7	18	27	J3	I	Analog	
AN8	21	32	K4	I	Analog	
AN9	22	33	L4	I	Analog	
AN10	23	34	L5	I	Analog	
AN11	24	35	J5	I	Analog	
AN12	27	41	J7	I	Analog	
AN13	28	42	L7	I	Analog	
AN14	29	43	K7	I	Analog	
AN15	30	44	L8	I	Analog	
CLKI	39	63	F9	I	ST/CMOS	External clock source input. Always associated with OSC1 pin function.
CLKO	40	64	F11	O	—	Oscillator crystal output. Connects to crystal or resonator in Crystal Oscillator mode. Optionally functions as CLKO in RC and EC modes. Always associated with OSC2 pin function.
OSC1	39	63	F9	I	ST/CMOS	Oscillator crystal input. ST buffer when configured in RC mode; CMOS otherwise.
OSC2	40	64	F11	I/O	—	Oscillator crystal output. Connects to crystal or resonator in Crystal Oscillator mode. Optionally functions as CLKO in RC and EC modes.
SOSCI	47	73	C10	I	ST/CMOS	32.768 kHz low-power oscillator crystal input; CMOS otherwise.
SOSCO	48	74	B11	O	—	32.768 kHz low-power oscillator crystal output.

Legend: CMOS = CMOS compatible input or output Analog = Analog input P = Power
 ST = Schmitt Trigger input with CMOS levels O = Output I = Input
 TTL = TTL input buffer

- Note 1:** Pin numbers are provided for reference only. See the “[Pin Diagrams](#)” section for device pin availability.
2: See [Section 24.0 “Ethernet Controller”](#) for more information.

TABLE 1-1: PINOUT I/O DESCRIPTIONS (CONTINUED)

Pin Name	Pin Number ⁽¹⁾			Pin Type	Buffer Type	Description
	64-Pin QFN/TQFP	100-Pin TQFP	121-Pin XBGA			
CN0	48	74	B11	I	ST	Change notification inputs. Can be software programmed for internal weak pull-ups on all inputs.
CN1	47	73	C10	I	ST	
CN2	16	25	K2	I	ST	
CN3	15	24	K1	I	ST	
CN4	14	23	J2	I	ST	
CN5	13	22	J1	I	ST	
CN6	12	21	H2	I	ST	
CN7	11	20	H1	I	ST	
CN8	4	10	E3	I	ST	
CN9	5	11	F4	I	ST	
CN10	6	12	F2	I	ST	
CN11	8	14	F3	I	ST	
CN12	30	44	L8	I	ST	
CN13	52	81	C8	I	ST	
CN14	53	82	B8	I	ST	
CN15	54	83	D7	I	ST	
CN16	55	84	C7	I	ST	
CN17	31	49	L10	I	ST	
CN18	32	50	L11	I	ST	
CN19	—	80	D8	I	ST	
CN20	—	47	L9	I	ST	
CN21	—	48	K9	I	ST	
IC1	42	68	E9	I	ST	Capture Inputs 1-5
IC2	43	69	E10	I	ST	
IC3	44	70	D11	I	ST	
IC4	45	71	C11	I	ST	
IC5	52	79	A9	I	ST	
OCFA	17	26	L1	I	ST	Output Compare Fault A Input
OC1	46	72	D9	O	—	Output Compare Output 1
OC2	49	76	A11	O	—	Output Compare Output 2
OC3	50	77	A10	O	—	Output Compare Output 3
OC4	51	78	B9	O	—	Output Compare Output 4
OC5	52	81	C8	O	—	Output Compare Output 5
OCFB	30	44	L8	I	ST	Output Compare Fault B Input
INT0	46	72	D9	I	ST	External Interrupt 0
INT1	42	18	G1	I	ST	External Interrupt 1
INT2	43	19	G2	I	ST	External Interrupt 2
INT3	44	66	E11	I	ST	External Interrupt 3
INT4	45	67	E8	I	ST	External Interrupt 4

Legend: CMOS = CMOS compatible input or output Analog = Analog input P = Power
 ST = Schmitt Trigger input with CMOS levels O = Output I = Input
 TTL = TTL input buffer

Note 1: Pin numbers are provided for reference only. See the “[Pin Diagrams](#)” section for device pin availability.
2: See [Section 24.0 “Ethernet Controller”](#) for more information.

PIC32MX5XX/6XX/7XX

TABLE 1-1: PINOUT I/O DESCRIPTIONS (CONTINUED)

Pin Name	Pin Number ⁽¹⁾			Pin Type	Buffer Type	Description	
	64-Pin QFN/TQFP	100-Pin TQFP	121-Pin XBGA				
RA0	—	17	G3	I/O	ST	PORTA is a bidirectional I/O port	
RA1	—	38	J6	I/O	ST		
RA2	—	58	H11	I/O	ST		
RA3	—	59	G10	I/O	ST		
RA4	—	60	G11	I/O	ST		
RA5	—	61	G9	I/O	ST		
RA6	—	91	C5	I/O	ST		
RA7	—	92	B5	I/O	ST		
RA9	—	28	L2	I/O	ST		
RA10	—	29	K3	I/O	ST		
RA14	—	66	E11	I/O	ST		
RA15	—	67	E8	I/O	ST		
RB0	16	25	K2	I/O	ST		PORTB is a bidirectional I/O port
RB1	15	24	K1	I/O	ST		
RB2	14	23	J2	I/O	ST		
RB3	13	22	J1	I/O	ST		
RB4	12	21	H2	I/O	ST		
RB5	11	20	H1	I/O	ST		
RB6	17	26	L1	I/O	ST		
RB7	18	27	J3	I/O	ST		
RB8	21	32	K4	I/O	ST		
RB9	22	33	L4	I/O	ST		
RB10	23	34	L5	I/O	ST		
RB11	24	35	J5	I/O	ST		
RB12	27	41	J7	I/O	ST		
RB13	28	42	L7	I/O	ST		
RB14	29	43	K7	I/O	ST		
RB15	30	44	L8	I/O	ST		
RC1	—	6	D1	I/O	ST	PORTC is a bidirectional I/O port	
RC2	—	7	E4	I/O	ST		
RC3	—	8	E2	I/O	ST		
RC4	—	9	E1	I/O	ST		
RC12	39	63	F9	I/O	ST		
RC13	47	73	C10	I/O	ST		
RC14	48	74	B11	I/O	ST		
RC15	40	64	F11	I/O	ST		

Legend: CMOS = CMOS compatible input or output Analog = Analog input P = Power
 ST = Schmitt Trigger input with CMOS levels O = Output I = Input
 TTL = TTL input buffer

- Note 1:** Pin numbers are provided for reference only. See the “[Pin Diagrams](#)” section for device pin availability.
2: See [Section 24.0 “Ethernet Controller”](#) for more information.

TABLE 1-1: PINOUT I/O DESCRIPTIONS (CONTINUED)

Pin Name	Pin Number ⁽¹⁾			Pin Type	Buffer Type	Description
	64-Pin QFN/TQFP	100-Pin TQFP	121-Pin XBGA			
RD0	46	72	D9	I/O	ST	PORTD is a bidirectional I/O port
RD1	49	76	A11	I/O	ST	
RD2	50	77	A10	I/O	ST	
RD3	51	78	B9	I/O	ST	
RD4	52	81	C8	I/O	ST	
RD5	53	82	B8	I/O	ST	
RD6	54	83	D7	I/O	ST	
RD7	55	84	C7	I/O	ST	
RD8	42	68	E9	I/O	ST	
RD9	43	69	E10	I/O	ST	
RD10	44	70	D11	I/O	ST	
RD11	45	71	C11	I/O	ST	
RD12	—	79	A9	I/O	ST	
RD13	—	80	D8	I/O	ST	
RD14	—	47	L9	I/O	ST	
RD15	—	48	K9	I/O	ST	
RE0	60	93	A4	I/O	ST	PORTE is a bidirectional I/O port
RE1	61	94	B4	I/O	ST	
RE2	62	98	B3	I/O	ST	
RE3	63	99	A2	I/O	ST	
RE4	64	100	A1	I/O	ST	
RE5	1	3	D3	I/O	ST	
RE6	2	4	C1	I/O	ST	
RE7	3	5	D2	I/O	ST	
RE8	—	18	G1	I/O	ST	
RE9	—	19	G2	I/O	ST	
RF0	58	87	B6	I/O	ST	PORTF is a bidirectional I/O port
RF1	59	88	A6	I/O	ST	
RF2	—	52	K11	I/O	ST	
RF3	33	51	K10	I/O	ST	
RF4	31	49	L10	I/O	ST	
RF5	32	50	L11	I/O	ST	
RF8	—	53	J10	I/O	ST	
RF12	—	40	K6	I/O	ST	
RF13	—	39	L6	I/O	ST	

Legend: CMOS = CMOS compatible input or output Analog = Analog input P = Power
 ST = Schmitt Trigger input with CMOS levels O = Output I = Input
 TTL = TTL input buffer

Note 1: Pin numbers are provided for reference only. See the “[Pin Diagrams](#)” section for device pin availability.
2: See [Section 24.0 “Ethernet Controller”](#) for more information.

PIC32MX5XX/6XX/7XX

TABLE 1-1: PINOUT I/O DESCRIPTIONS (CONTINUED)

Pin Name	Pin Number ⁽¹⁾			Pin Type	Buffer Type	Description
	64-Pin QFN/TQFP	100-Pin TQFP	121-Pin XBGA			
RG0	—	90	A5	I/O	ST	PORTG is a bidirectional I/O port
RG1	—	89	E6	I/O	ST	
RG6	4	10	E3	I/O	ST	
RG7	5	11	F4	I/O	ST	
RG8	6	12	F2	I/O	ST	
RG9	8	14	F3	I/O	ST	
RG12	—	96	C3	I/O	ST	
RG13	—	97	A3	I/O	ST	
RG14	—	95	C4	I/O	ST	
RG15	—	1	B2	I/O	ST	
RG2	37	57	H10	I	ST	PORTG input pins
RG3	36	56	J11	I	ST	
T1CK	48	74	B11	I	ST	Timer1 external clock input
T2CK	—	6	D1	I	ST	Timer2 external clock input
T3CK	—	7	E4	I	ST	Timer3 external clock input
T4CK	—	8	E2	I	ST	Timer4 external clock input
T5CK	—	9	E1	I	ST	Timer5 external clock input
$\overline{U1CTS}$	43	47	L9	I	ST	UART1 clear to send
$\overline{U1RTS}$	49	48	K9	O	—	UART1 ready to send
U1RX	50	52	K11	I	ST	UART1 receive
U1TX	51	53	J10	O	—	UART1 transmit
$\overline{U3CTS}$	8	14	F3	I	ST	UART3 clear to send
$\overline{U3RTS}$	4	10	E3	O	—	UART3 ready to send
U3RX	5	11	F4	I	ST	UART3 receive
U3TX	6	12	F2	O	—	UART3 transmit
$\overline{U2CTS}$	21	40	K6	I	ST	UART2 clear to send
$\overline{U2RTS}$	29	39	L6	O	—	UART2 ready to send
U2RX	31	49	L10	I	ST	UART2 receive
U2TX	32	50	L11	O	—	UART2 transmit
U4RX	43	47	L9	I	ST	UART4 receive
U4TX	49	48	K9	O	—	UART4 transmit
U6RX	8	14	F3	I	ST	UART6 receive
U6TX	4	10	E3	O	—	UART6 transmit
U5RX	21	40	K6	I	ST	UART5 receive
U5TX	29	39	L6	O	—	UART5 transmit
SCK1	—	70	D11	I/O	ST	Synchronous serial clock input/output for SPI1
SDI1	—	9	E1	I	ST	SPI1 data in
SDO1	—	72	D9	O	—	SPI1 data out

Legend: CMOS = CMOS compatible input or output
 ST = Schmitt Trigger input with CMOS levels
 TTL = TTL input buffer

Analog = Analog input
 O = Output

P = Power
 I = Input

Note 1: Pin numbers are provided for reference only. See the “[Pin Diagrams](#)” section for device pin availability.

2: See [Section 24.0 “Ethernet Controller”](#) for more information.

TABLE 1-1: PINOUT I/O DESCRIPTIONS (CONTINUED)

Pin Name	Pin Number ⁽¹⁾			Pin Type	Buffer Type	Description
	64-Pin QFN/TQFP	100-Pin TQFP	121-Pin XBGA			
SS1	—	69	E10	I/O	ST	SPI1 slave synchronization or frame pulse I/O
SCK3	49	48	K9	I/O	ST	Synchronous serial clock input/output for SPI3
SDI3	50	52	K11	I	ST	SPI3 data in
SDO3	51	53	J10	O	—	SPI3 data out
SS3	43	47	L9	I/O	ST	SPI3 slave synchronization or frame pulse I/O
SCK2	4	10	E3	I/O	ST	Synchronous serial clock input/output for SPI2
SDI2	5	11	F4	I	ST	SPI2 data in
SDO2	6	12	F2	O	—	SPI2 data out
SS2	8	14	F3	I/O	ST	SPI2 slave synchronization or frame pulse I/O
SCK4	29	39	L6	I/O	ST	Synchronous serial clock input/output for SPI4
SDI4	31	49	L10	I	ST	SPI4 data in
SDO4	32	50	L11	O	—	SPI4 data out
SS4	21	40	K6	I/O	ST	SPI4 slave synchronization or frame pulse I/O
SCL1	44	66	E11	I/O	ST	Synchronous serial clock input/output for I2C1
SDA1	43	67	E8	I/O	ST	Synchronous serial data input/output for I2C1
SCL3	51	53	J10	I/O	ST	Synchronous serial clock input/output for I2C3
SDA3	50	52	K11	I/O	ST	Synchronous serial data input/output for I2C3
SCL2	—	58	H11	I/O	ST	Synchronous serial clock input/output for I2C2
SDA2	—	59	G10	I/O	ST	Synchronous serial data input/output for I2C2
SCL4	6	12	F2	I/O	ST	Synchronous serial clock input/output for I2C4
SDA4	5	11	F4	I/O	ST	Synchronous serial data input/output for I2C4
SCL5	32	50	L11	I/O	ST	Synchronous serial clock input/output for I2C5
SDA5	31	49	L10	I/O	ST	Synchronous serial data input/output for I2C5
TMS	23	17	G3	I	ST	JTAG Test mode select pin
TCK	27	38	J6	I	ST	JTAG test clock input pin
TDI	28	60	G11	I	ST	JTAG test data input pin
TDO	24	61	G9	O	—	JTAG test data output pin
RTCC	42	68	E9	O	—	Real-Time Clock alarm output
CVREF-	15	28	L2	I	Analog	Comparator Voltage Reference (low)
CVREF+	16	29	K3	I	Analog	Comparator Voltage Reference (high)
CVREFOUT	23	34	L5	O	Analog	Comparator Voltage Reference output
C1IN-	12	21	H2	I	Analog	Comparator 1 negative input
C1IN+	11	20	H1	I	Analog	Comparator 1 positive input
C1OUT	21	32	K4	O	—	Comparator 1 output
C2IN-	14	23	J2	I	Analog	Comparator 2 negative input
C2IN+	13	22	J1	I	Analog	Comparator 2 positive input
C2OUT	22	33	L4	O	—	Comparator 2 output

Legend: CMOS = CMOS compatible input or output Analog = Analog input P = Power
 ST = Schmitt Trigger input with CMOS levels O = Output I = Input
 TTL = TTL input buffer

Note 1: Pin numbers are provided for reference only. See the “[Pin Diagrams](#)” section for device pin availability.
2: See [Section 24.0 “Ethernet Controller”](#) for more information.

PIC32MX5XX/6XX/7XX

TABLE 1-1: PINOUT I/O DESCRIPTIONS (CONTINUED)

Pin Name	Pin Number ⁽¹⁾			Pin Type	Buffer Type	Description
	64-Pin QFN/TQFP	100-Pin TQFP	121-Pin XBGA			
PMA0	30	44	L8	I/O	TTL/ST	Parallel Master Port Address bit 0 input (Buffered Slave modes) and output (Master modes)
PMA1	29	43	K7	I/O	TTL/ST	Parallel Master Port Address bit 1 input (Buffered Slave modes) and output (Master modes)
PMA2	8	14	F3	O	—	Parallel Master Port address (Demultiplexed Master modes)
PMA3	6	12	F2	O	—	
PMA4	5	11	F4	O	—	
PMA5	4	10	E3	O	—	
PMA6	16	29	K3	O	—	
PMA7	22	28	L2	O	—	
PMA8	32	50	L11	O	—	
PMA9	31	49	L10	O	—	
PMA10	28	42	L7	O	—	
PMA11	27	41	J7	O	—	
PMA12	24	35	J5	O	—	
PMA13	23	34	L5	O	—	
PMA14	45	71	C11	O	—	
PMA15	44	70	D11	O	—	
PMCS1	45	71	C11	O	—	
PMCS2	44	70	D11	O	—	Parallel Master Port Chip Select 2 strobe
PMD0	60	93	A4	I/O	TTL/ST	Parallel Master Port data (Demultiplexed Master mode) or address/data (Multiplexed Master modes)
PMD1	61	94	B4	I/O	TTL/ST	
PMD2	62	98	B3	I/O	TTL/ST	
PMD3	63	99	A2	I/O	TTL/ST	
PMD4	64	100	A1	I/O	TTL/ST	
PMD5	1	3	D3	I/O	TTL/ST	
PMD6	2	4	C1	I/O	TTL/ST	
PMD7	3	5	D2	I/O	TTL/ST	
PMD8	—	90	A5	I/O	TTL/ST	
PMD9	—	89	E6	I/O	TTL/ST	
PMD10	—	88	A6	I/O	TTL/ST	
PMD11	—	87	B6	I/O	TTL/ST	
PMD12	—	79	A9	I/O	TTL/ST	
PMD13	—	80	D8	I/O	TTL/ST	
PMD14	—	83	D7	I/O	TTL/ST	
PMD15	—	84	C7	I/O	TTL/ST	

Legend: CMOS = CMOS compatible input or output Analog = Analog input P = Power
 ST = Schmitt Trigger input with CMOS levels O = Output I = Input
 TTL = TTL input buffer

Note 1: Pin numbers are provided for reference only. See the “[Pin Diagrams](#)” section for device pin availability.
2: See [Section 24.0 “Ethernet Controller”](#) for more information.

TABLE 1-1: PINOUT I/O DESCRIPTIONS (CONTINUED)

Pin Name	Pin Number ⁽¹⁾			Pin Type	Buffer Type	Description
	64-Pin QFN/TQFP	100-Pin TQFP	121-Pin XBGA			
PMALL	30	44	L8	O	—	Parallel Master Port address latch enable low byte (Multiplexed Master modes)
PMALH	29	43	K7	O	—	Parallel Master Port address latch enable high byte (Multiplexed Master modes)
PMRD	53	82	B8	O	—	Parallel Master Port read strobe
PMWR	52	81	C8	O	—	Parallel Master Port write strobe
VBUS	34	54	H8	I	Analog	USB bus power monitor
VUSB	35	55	H9	P	—	USB internal transceiver supply. If the USB module is <i>not</i> used, this pin must be connected to VDD.
VBUSON	11	20	H1	O	—	USB Host and OTG bus power control output
D+	37	57	H10	I/O	Analog	USB D+
D-	36	56	J11	I/O	Analog	USB D-
USBID	33	51	K10	I	ST	USB OTG ID detect
C1RX	58	87	B6	I	ST	CAN1 bus receive pin
C1TX	59	88	A6	O	—	CAN1 bus transmit pin
AC1RX	32	40	K6	I	ST	Alternate CAN1 bus receive pin
AC1TX	31	39	L6	O	—	Alternate CAN1 bus transmit pin
C2RX	29	90	A5	I	ST	CAN2 bus receive pin
C2TX	21	89	E6	O	—	CAN2 bus transmit pin
AC2RX	—	8	E2	I	ST	Alternate CAN2 bus receive pin
AC2TX	—	7	E4	O	—	Alternate CAN2 bus transmit pin
ERXD0	61	41	J7	I	ST	Ethernet Receive Data 0 ⁽²⁾
ERXD1	60	42	L7	I	ST	Ethernet Receive Data 1 ⁽²⁾
ERXD2	59	43	K7	I	ST	Ethernet Receive Data 2 ⁽²⁾
ERXD3	58	44	L8	I	ST	Ethernet Receive Data 3 ⁽²⁾
ERXERR	64	35	J5	I	ST	Ethernet receive error input ⁽²⁾
ERXDV	62	12	F2	I	ST	Ethernet receive data valid ⁽²⁾
ECRS DV	62	12	F2	I	ST	Ethernet carrier sense data valid ⁽²⁾
ERXCLK	63	14	F3	I	ST	Ethernet receive clock ⁽²⁾
EREFCLK	63	14	F3	I	ST	Ethernet reference clock ⁽²⁾
ETXD0	2	88	A6	O	—	Ethernet Transmit Data 0 ⁽²⁾
ETXD1	3	87	B6	O	—	Ethernet Transmit Data 1 ⁽²⁾
ETXD2	43	79	A9	O	—	Ethernet Transmit Data 2 ⁽²⁾
ETXD3	42	80	D8	O	—	Ethernet Transmit Data 3 ⁽²⁾
ETXERR	54	89	E6	O	—	Ethernet transmit error ⁽²⁾
ETXEN	1	83	D7	O	—	Ethernet transmit enable ⁽²⁾
ETXCLK	55	84	C7	I	ST	Ethernet transmit clock ⁽²⁾
ECOL	44	10	E3	I	ST	Ethernet collision detect ⁽²⁾
ECRS	45	11	F4	I	ST	Ethernet carrier sense ⁽²⁾

Legend: CMOS = CMOS compatible input or output
 ST = Schmitt Trigger input with CMOS levels
 TTL = TTL input buffer
 Analog = Analog input
 O = Output
 P = Power
 I = Input

Note 1: Pin numbers are provided for reference only. See the “[Pin Diagrams](#)” section for device pin availability.
2: See [Section 24.0 “Ethernet Controller”](#) for more information.

PIC32MX5XX/6XX/7XX

TABLE 1-1: PINOUT I/O DESCRIPTIONS (CONTINUED)

Pin Name	Pin Number ⁽¹⁾			Pin Type	Buffer Type	Description
	64-Pin QFN/TQFP	100-Pin TQFP	121-Pin XBGA			
EMDC	30	71	C11	O	—	Ethernet management data clock ⁽²⁾
EMDIO	49	68	E9	I/O	—	Ethernet management data ⁽²⁾
AERXD0	43	18	G1	I	ST	Alternate Ethernet Receive Data 0 ⁽²⁾
AERXD1	42	19	G2	I	ST	Alternate Ethernet Receive Data 1 ⁽²⁾
AERXD2	—	28	L2	I	ST	Alternate Ethernet Receive Data 2 ⁽²⁾
AERXD3	—	29	K3	I	ST	Alternate Ethernet Receive Data 3 ⁽²⁾
AERXERR	55	1	B2	I	ST	Alternate Ethernet receive error input ⁽²⁾
AERXDV	—	12	F2	I	ST	Alternate Ethernet receive data valid ⁽²⁾
AECRSDV	44	12	F2	I	ST	Alternate Ethernet carrier sense data valid ⁽²⁾
AERXCLK	—	14	F3	I	ST	Alternate Ethernet receive clock ⁽²⁾
AEREFCLK	45	14	F3	I	ST	Alternate Ethernet reference clock ⁽²⁾
AETXD0	59	47	L9	O	—	Alternate Ethernet Transmit Data 0 ⁽²⁾
AETXD1	58	48	K9	O	—	Alternate Ethernet Transmit Data 1 ⁽²⁾
AETXD2	—	44	L8	O	—	Alternate Ethernet Transmit Data 2 ⁽²⁾
AETXD3	—	43	K7	O	—	Alternate Ethernet Transmit Data 3 ⁽²⁾
AETXERR	—	35	J5	O	—	Alternate Ethernet transmit error ⁽²⁾
AETXEN	54	67	E8	O	—	Alternate Ethernet transmit enable ⁽²⁾
AETXCLK	—	66	E11	I	ST	Alternate Ethernet transmit clock ⁽²⁾
AECOL	—	42	L7	I	ST	Alternate Ethernet collision detect ⁽²⁾
AECRS	—	41	J7	I	ST	Alternate Ethernet carrier sense ⁽²⁾
AEMDC	30	71	C11	O	—	Alternate Ethernet Management Data clock ⁽²⁾
AEMDIO	49	68	E9	I/O	—	Alternate Ethernet Management Data ⁽²⁾
TRCLK	—	91	C5	O	—	Trace clock
TRD0	—	97	A3	O	—	Trace Data bits 0-3
TRD1	—	96	C3	O	—	
TRD2	—	95	C4	O	—	
TRD3	—	92	B5	O	—	
PGED1	16	25	K2	I/O	ST	Data I/O pin for Programming/Debugging Communication Channel 1
PGEC1	15	24	K1	I	ST	Clock input pin for Programming/Debugging Communication Channel 1
PGED2	18	27	J3	I/O	ST	Data I/O pin for Programming/Debugging Communication Channel 2
PGEC2	17	26	L1	I	ST	Clock input pin for Programming/Debugging Communication Channel 2
MCLR	7	13	F1	I/P	ST	Master Clear (Reset) input. This pin is an active-low Reset to the device.

Legend: CMOS = CMOS compatible input or output
 ST = Schmitt Trigger input with CMOS levels
 TTL = TTL input buffer

Analog = Analog input
 O = Output
 P = Power
 I = Input

Note 1: Pin numbers are provided for reference only. See the “**Pin Diagrams**” section for device pin availability.
2: See **Section 24.0 “Ethernet Controller”** for more information.

TABLE 1-1: PINOUT I/O DESCRIPTIONS (CONTINUED)

Pin Name	Pin Number ⁽¹⁾			Pin Type	Buffer Type	Description
	64-Pin QFN/TQFP	100-Pin TQFP	121-Pin XBGA			
AVDD	19	30	J4	P	P	Positive supply for analog modules. This pin must be connected at all times.
AVSS	20	31	L3	P	P	Ground reference for analog modules
VDD	10, 26, 38, 57	2, 16, 37, 46, 62, 86	A7, C2, C9, E5, K8, F8, G5, H4, H6	P	—	Positive supply for peripheral logic and I/O pins
VCAP/VCORE	56	85	B7	P	—	Capacitor for Internal Voltage Regulator
VSS	9, 25, 41	15, 36, 45, 65, 75	A8, B10, D4, D5, E7, F5, F10, G6, G7, H3	P	—	Ground reference for logic and I/O pins. This pin must be connected at all times.
VREF+	16	29	K3	I	Analog	Analog voltage reference (high) input
VREF-	15	28	L2	I	Analog	Analog voltage reference (low) input

Legend: CMOS = CMOS compatible input or output Analog = Analog input P = Power
 ST = Schmitt Trigger input with CMOS levels O = Output I = Input
 TTL = TTL input buffer

- Note 1:** Pin numbers are provided for reference only. See the “[Pin Diagrams](#)” section for device pin availability.
2: See [Section 24.0 “Ethernet Controller”](#) for more information.

PIC32MX5XX/6XX/7XX

NOTES:

2.0 GUIDELINES FOR GETTING STARTED WITH 32-BIT MICROCONTROLLERS

Note 1: This data sheet summarizes the features of the PIC32MX5XX/6XX/7XX family of devices. It is not intended to be a comprehensive reference source. To complement the information in this data sheet, refer to the related section of the “PIC32 Family Reference Manual”, which is available from the Microchip web site (www.microchip.com/PIC32).

2: Some registers and associated bits described in this section may not be available on all devices. Refer to **Section 4.0 “Memory Organization”** in this data sheet for device-specific register and bit information.

2.1 Basic Connection Requirements

Getting started with the PIC32MX5XX/6XX/7XX family of 32-bit Microcontrollers (MCUs) requires attention to a minimal set of device pin connections before proceeding with development. The following is a list of pin names, which must always be connected:

- All VDD and VSS pins
(see **Section 2.2 “Decoupling Capacitors”**)
- All AVDD and AVSS pins even if the ADC module is not used
(see **Section 2.2 “Decoupling Capacitors”**)
- VCAP/VCORE pin
(see **Section 2.3 “Capacitor on Internal Voltage Regulator (VCAP/VCORE)”**)
- MCLR pin
(see **Section 2.4 “Master Clear (MCLR) Pin”**)
- PGECx/PGEDx pins used for In-Circuit Serial Programming™ (ICSP™) and debugging purposes
(see **Section 2.5 “ICSP Pins”**)
- OSC1 and OSC2 pins when external oscillator source is used
(see **Section 2.8 “External Oscillator Pins”**)

The following pin may be required, as well:

VREF+/VREF- pins used when external voltage reference for ADC module is implemented

Note: The AVDD and AVSS pins must be connected, regardless of the ADC use and the ADC voltage reference source.

2.2 Decoupling Capacitors

The use of decoupling capacitors on power supply pins, such as VDD, VSS, AVDD and AVSS is required. See **Figure 2-1**.

Consider the following criteria when using decoupling capacitors:

- **Value and type of capacitor:** A value of 0.1 μF (100 nF), 10-20V is recommended. The capacitor should be a low Equivalent Series Resistance (low-ESR) capacitor and have resonance frequency in the range of 20 MHz and higher. It is further recommended to use ceramic capacitors.
- **Placement on the printed circuit board:** The decoupling capacitors should be placed as close to the pins as possible. It is recommended that the capacitors be placed on the same side of the board as the device. If space is constricted, the capacitor can be placed on another layer on the PCB using a via; however, ensure that the trace length from the pin to the capacitor is within one-quarter inch (6 mm) in length.
- **Handling high frequency noise:** If the board is experiencing high frequency noise, upward of tens of MHz, add a second ceramic-type capacitor in parallel to the above described decoupling capacitor. The value of the second capacitor can be in the range of 0.01 μF to 0.001 μF . Place this second capacitor next to the primary decoupling capacitor. In high-speed circuit designs, consider implementing a decade pair of capacitances as close to the power and ground pins as possible. For example, 0.1 μF in parallel with 0.001 μF .
- **Maximizing performance:** On the board layout from the power supply circuit, run the power and return traces to the decoupling capacitors first, and then to the device pins. This ensures that the decoupling capacitors are first in the power chain. Equally important is to keep the trace length between the capacitor and the power pins to a minimum, thereby reducing PCB track inductance.

FIGURE 2-1: RECOMMENDED MINIMUM CONNECTION

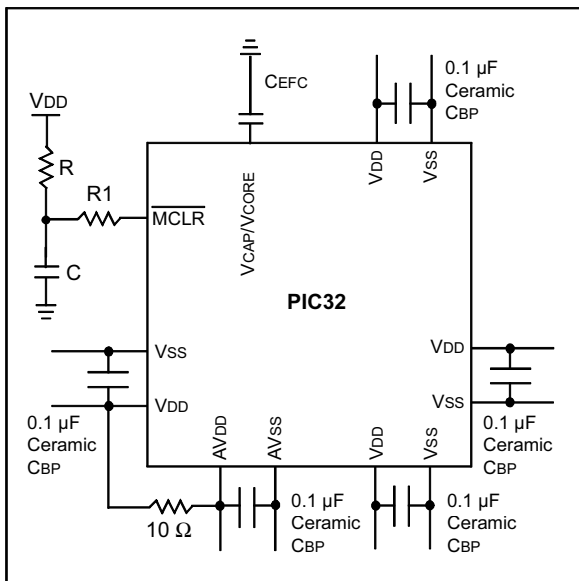

2.2.1 BULK CAPACITORS

The use of a bulk capacitor is recommended to improve power supply stability. Typical values range from 4.7 μF to 47 μF . This capacitor should be located as close to the device as possible.

2.3 Capacitor on Internal Voltage Regulator (VCAP/VCORE)

2.3.1 INTERNAL REGULATOR MODE

A low-ESR (1 ohm) capacitor is required on the VCAP/VCORE pin, which is used to stabilize the internal voltage regulator output. The VCAP/VCORE pin must not be connected to VDD, and must have a CEFC capacitor, with at least a 6V rating, connected to ground. The type can be ceramic or tantalum. Refer to [Section 31.0 "Electrical Characteristics"](#) for additional information on CEFC specifications.

2.4 Master Clear ($\overline{\text{MCLR}}$) Pin

The $\overline{\text{MCLR}}$ pin provides two specific device functions:

- Device Reset
- Device Programming and Debugging

Pulling The $\overline{\text{MCLR}}$ pin low generates a device Reset. [Figure 2-2](#) illustrates a typical $\overline{\text{MCLR}}$ circuit. During device programming and debugging, the resistance and capacitance that can be added to the pin must be considered. Device programmers and debuggers drive the MCLR pin. Consequently, specific voltage levels (V_{IH} and V_{IL}) and fast signal transitions must not be adversely affected. Therefore, specific values of R and C will need to be adjusted based on the application and PCB requirements.

For example, as illustrated in [Figure 2-2](#), it is recommended that the capacitor C, be isolated from the $\overline{\text{MCLR}}$ pin during programming and debugging operations.

Place the components illustrated in [Figure 2-2](#) within one-quarter inch (6 mm) from the $\overline{\text{MCLR}}$ pin.

FIGURE 2-2: EXAMPLE OF $\overline{\text{MCLR}}$ PIN CONNECTIONS

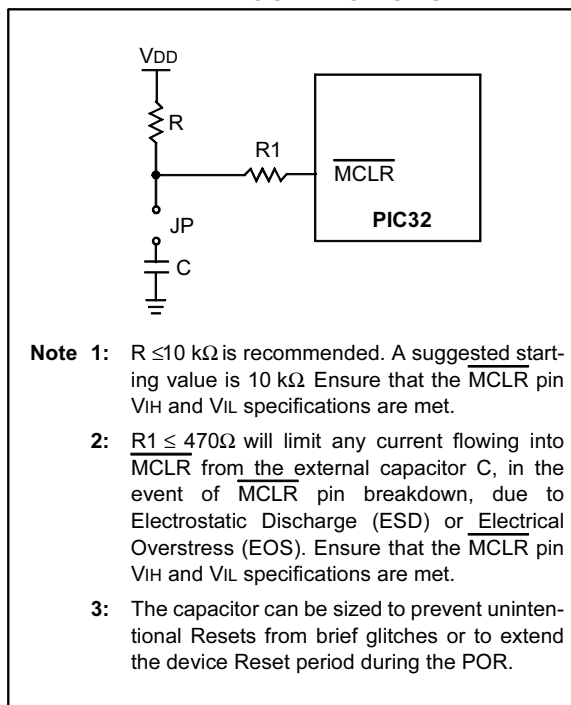

2.5 ICSP Pins

The PGECx and PGEDx pins are used for In-Circuit Serial Programming™ (ICSP™) and debugging purposes. It is recommended to keep the trace length between the ICSP connector and the ICSP pins on the device as short as possible. If the ICSP connector is expected to experience an ESD event, a series resistor is recommended, with the value in the range of a few tens of Ohms, not to exceed 100 Ohms.

Pull-up resistors, series diodes and capacitors on the PGECx and PGEDx pins are not recommended as they will interfere with the programmer/debugger communications to the device. If such discrete components are an application requirement, they should be removed from the circuit during programming and debugging. Alternatively, refer to the AC/DC characteristics and timing requirements information in the respective device Flash programming specification for information on capacitive loading limits and pin input voltage high (V_{IH}) and input low (V_{IL}) requirements.

Ensure that the “Communication Channel Select” (i.e., PGECx/PGEDx pins) programmed into the device matches the physical connections for the ICSP to MPLAB® ICD 2, MPLAB® ICD 3 or MPLAB® REAL ICE™.

For more information on ICD 2, ICD 3 and REAL ICE connection requirements, refer to the following documents that are available on the Microchip web site.

- “MPLAB® ICD 2 In-Circuit Debugger User’s Guide” DS51331
- “Using MPLAB® ICD 2” (poster) DS51265
- “MPLAB® ICD 2 Design Advisory” DS51566
- “Using MPLAB® ICD 3” (poster) DS51765
- “MPLAB® ICD 3 Design Advisory” DS51764
- “MPLAB® REAL ICE™ In-Circuit Emulator User’s Guide” DS51616
- “Using MPLAB® REAL ICE™ Emulator” (poster) DS51749

2.6 JTAG

The TMS, TDO, TDI and TCK pins are used for testing and debugging according to the Joint Test Action Group (JTAG) standard. It is recommended to keep the trace length between the JTAG connector and the JTAG pins on the device as short as possible. If the JTAG connector is expected to experience an ESD event, a series resistor is recommended, with the value in the range of a few tens of Ohms, not to exceed 100 Ohms.

Pull-up resistors, series diodes and capacitors on the TMS, TDO, TDI and TCK pins are not recommended as they will interfere with the programmer/debugger communications to the device. If such discrete components are an application requirement, they should be removed from the circuit during programming and debugging. Alternatively, refer to the AC/DC characteristics and timing requirements information in the respective device Flash programming specification for information on capacitive loading limits and pin input voltage high (V_{IH}) and input low (V_{IL}) requirements.

2.7 Trace

The trace pins can be connected to a hardware-trace-enabled programmer to provide a compressed real time instruction trace. When used for trace the TRD3, TRD2, TRD1, TRD0 and TRCLK pins should be dedicated for this use. The trace hardware requires a 22Ω series resistor between the trace pins and the trace connector.

2.8 External Oscillator Pins

Many MCUs have options for at least two oscillators: a high-frequency primary oscillator and a low-frequency secondary oscillator. Refer to [Section 8.0 “Oscillator Configuration”](#) for details.

The oscillator circuit should be placed on the same side of the board as the device. Also, place the oscillator circuit close to the respective oscillator pins, not exceeding one-half inch (12 mm) distance between them. The load capacitors should be placed next to the oscillator itself, on the same side of the board. Use a grounded copper pour around the oscillator circuit to isolate them from surrounding circuits. The grounded copper pour should be routed directly to the MCU ground. Do not run any signal traces or power traces inside the ground pour. Also, if using a two-sided board, avoid any traces on the other side of the board where the crystal is placed. A suggested layout is illustrated in [Figure 2-3](#).

FIGURE 2-3: SUGGESTED OSCILLATOR CIRCUIT PLACEMENT

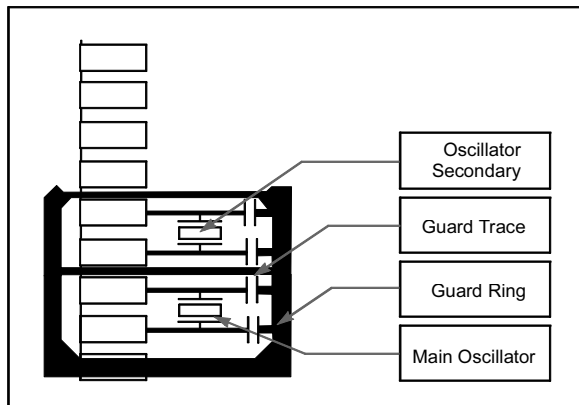

2.9 Configuration of Analog and Digital Pins During ICSP Operations

If MPLAB ICD 2, ICD 3 or REAL ICE is selected as a debugger, it automatically initializes all of the Analog-to-Digital input pins (ANx) as “digital” pins by setting all bits in the ADPCFG register.

The bits in this register that correspond to the Analog-to-Digital pins that are initialized by MPLAB ICD 2, ICD 3 or REAL ICE, must not be cleared by the user application firmware; otherwise, communication errors will result between the debugger and the device.

If your application needs to use certain ADC pins as analog input pins during the debug session, the user application must clear the corresponding bits in the ADPCFG register during initialization of the ADC module.

When MPLAB ICD 2, ICD 3 or REAL ICE is used as a programmer, the user application firmware must correctly configure the ADPCFG register. Automatic initialization of this register is only done during debugger operation. Failure to correctly configure the register(s) will result in all ADC pins being recognized as analog input pins, resulting in the port value being read as a logic ‘0’, which may affect user application functionality.

2.10 Unused I/Os

Unused I/O pins should not be allowed to float as inputs. They can be configured as outputs and driven to a logic-low state.

Alternatively, inputs can be reserved by connecting the pin to Vss through a 1k to 10k resistor and configuring the pin as an input.

2.11 Referenced Sources

This device data sheet is based on the following individual chapters of the “PIC32 Family Reference Manual”. These documents should be considered as the general reference for the operation of a particular module or device feature.

Note 1: To access the documents listed below, browse to the documentation section of the PIC32MX795F512L product page on the Microchip web site (www.microchip.com) or select a family reference manual section from the following list.

In addition to parameters, features, and other documentation, the resulting page provides links to the related family reference manual sections.

- **Section 1. “Introduction”** (DS61127)
- **Section 2. “CPU”** (DS61113)
- **Section 4. “Prefetch Cache”** (DS61119)
- **Section 3. “Memory Organization”** (DS61115)
- **Section 5. “Flash Program Memory”** (DS61121)
- **Section 6. “Oscillator Configuration”** (DS61112)
- **Section 7. “Resets”** (DS61118)
- **Section 8. “Interrupt Controller”** (DS61108)
- **Section 9. “Watchdog Timer and Power-up Timer** (DS61114)
- **Section 10. “Power-Saving Features”** (DS61130)
- **Section 12. “I/O Ports”** (DS61120)
- **Section 13. “Parallel Master Port (PMP)”** (DS61128)
- **Section 14. “Timers”** (DS61105)
- **Section 15. “Input Capture”** (DS61122)
- **Section 16. “Output Capture”** (DS61111)
- **Section 17. “10-bit Analog-to-Digital Converter (ADC)”** (DS61104)
- **Section 19. “Comparator”** (DS61110)
- **Section 20. “Comparator Voltage Reference (CVREF)”** (DS61109)
- **Section 21. “Universal Asynchronous Receiver Transmitter (UART)”** (DS61107)
- **Section 23. “Serial Peripheral Interface (SPI)”** (DS61106)
- **Section 24. “Inter-Integrated Circuit (I2C™)”** (DS61116)
- **Section 27. “USB On-The-Go (OTG)”** (DS61126)
- **Section 29. “Real-Time Clock and Calendar (RTCC)”** (DS61125)
- **Section 31. “Direct Memory Access (DMA) Controller”** (DS61117)
- **Section 32. “Configuration”** (DS61124)
- **Section 33. “Programming and Diagnostics”** (DS61129)
- **Section 34. “Controller Area Network (CAN)”** (DS61154)
- **Section 35. “Ethernet Controller”** (DS61155)

PIC32MX5XX/6XX/7XX

NOTES:

3.0 CPU

Note 1: This data sheet summarizes the features of the PIC32MX5XX/6XX/7XX family of devices. It is not intended to be a comprehensive reference source. To complement the information in this data sheet, refer to **Section 2. "CPU"** (DS61113) in the "PIC32 Family Reference Manual", which is available from the Microchip web site (www.microchip.com/PIC32). Resources for the MIPS32® M4K® Processor Core are available at <http://www.mips.com>.

2: Some registers and associated bits described in this section may not be available on all devices. Refer to **Section 4.0 "Memory Organization"** in this data sheet for device-specific register and bit information.

The MIPS32® M4K® Processor core is the heart of the PIC32MX5XX/6XX/7XX family processor. The CPU fetches instructions, decodes each instruction, fetches source operands, executes each instruction and writes the results of instruction execution to the proper destinations.

3.1 Features

- 5-stage pipeline
- 32-bit address and data paths
- MIPS32 Enhanced Architecture (Release 2)
 - Multiply-accumulate and multiply-subtract instructions
 - Targeted multiply instruction
 - Zero/One detect instructions
 - WAIT instruction
 - Conditional move instructions (MOVN, MOVZ)
 - Vectored interrupts
 - Programmable exception vector base

- Atomic interrupt enable/disable
- GPR shadow registers to minimize latency for interrupt handlers
- Bit field manipulation instructions
- MIPS16e® code compression
 - 16-bit encoding of 32-bit instructions to improve code density
 - Special PC-relative instructions for efficient loading of addresses and constants
 - SAVE and RESTORE macro instructions for setting up and tearing down stack frames within subroutines
 - Improved support for handling 8 and 16-bit data types
- Simple Fixed Mapping Translation (FMT) mechanism
- Simple dual bus interface
 - Independent 32-bit address and data busses
 - Transactions can be aborted to improve interrupt latency
- Autonomous multiply/divide unit
 - Maximum issue rate of one 32x16 multiply per clock
 - Maximum issue rate of one 32x32 multiply every other clock
 - Early-in iterative divide. Minimum 11 and maximum 33 clock latency (dividend (rs) sign extension-dependent)
- Power control
 - Minimum frequency: 0 MHz
 - Low-Power mode (triggered by WAIT instruction)
 - Extensive use of local gated clocks
- EJTAG debug and instruction trace
 - Support for single stepping
 - Virtual instruction and data address/value
 - Breakpoints
 - PC tracing with trace compression

FIGURE 3-1: MIPS® M4K® PROCESSOR CORE BLOCK DIAGRAM

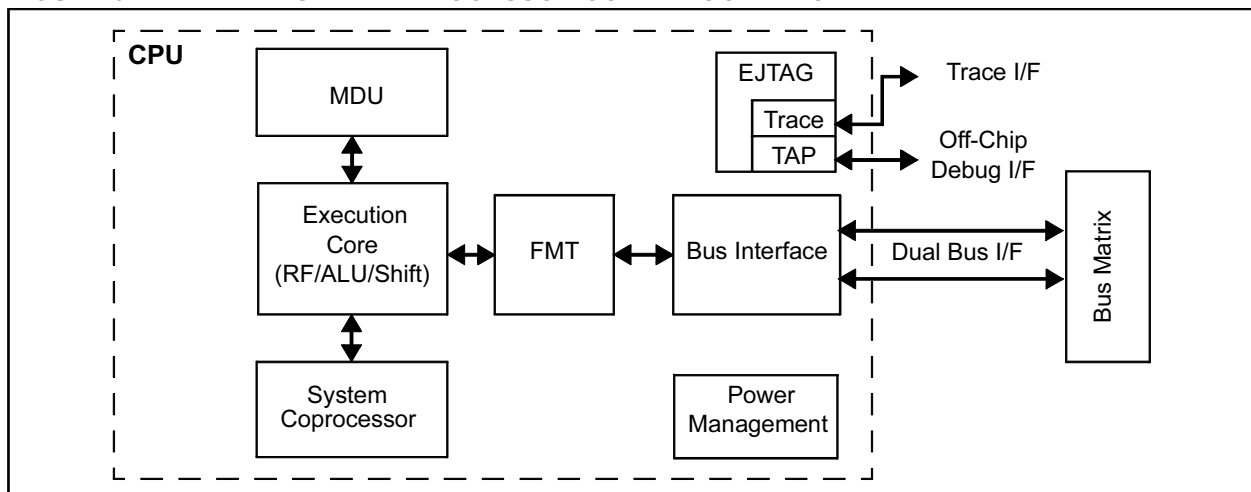

3.2 Architecture Overview

The MIPS® M4K® processor core contains several logic blocks working together in parallel, providing an efficient high-performance computing engine. The following blocks are included with the core:

- Execution Unit
- Multiply/Divide Unit (MDU)
- System Control Coprocessor (CP0)
- Fixed Mapping Translation (FMT)
- Dual Internal Bus interfaces
- Power Management
- MIPS16e Support
- Enhanced JTAG (EJTAG) Controller

3.2.1 EXECUTION UNIT

The MIPS M4K processor core execution unit implements a load/store architecture with single-cycle ALU operations (logical, shift, add, subtract) and an autonomous multiply/divide unit. The core contains thirty-two 32-bit General Purpose Registers (GPRs) used for integer operations and address calculation. One additional register file shadow set (containing thirty-two registers) is added to minimize context switching overhead during interrupt/exception processing. The register file consists of two read ports and one write port and is fully bypassed to minimize operation latency in the pipeline.

The execution unit includes:

- 32-bit adder used for calculating the data address
- Address unit for calculating the next instruction address
- Logic for branch determination and branch target address calculation
- Load aligner
- Bypass multiplexers used to avoid stalls when executing instruction streams where data producing instructions are followed closely by consumers of their results
- Leading Zero/One detect unit for implementing the `CLZ` and `CLO` instructions
- Arithmetic Logic Unit (ALU) for performing bitwise logical operations
- Shifter and store aligner

3.2.2 MULTIPLY/DIVIDE UNIT (MDU)

MIPS M4K processor core includes a Multiply/Divide Unit (MDU) that contains a separate pipeline for multiply and divide operations. This pipeline operates in parallel with the Integer Unit (IU) pipeline and does not stall when the IU pipeline stalls. This allows MDU operations to be partially masked by system stalls and/or other integer unit instructions.

The high-performance MDU consists of a 32x16 booth recoded multiplier, result/accumulation registers (HI and LO), a divide state machine, and the necessary multiplexers and control logic. The first number shown ('32' of 32x16) represents the *rs* operand. The second number ('16' of 32x16) represents the *rt* operand. The PIC32 core only checks the value of the latter (*rt*) operand to determine how many times the operation must pass through the multiplier. The 16x16 and 32x16 operations pass through the multiplier once. A 32x32 operation passes through the multiplier twice.

The MDU supports execution of one 16x16 or 32x16 multiply operation every clock cycle; 32x32 multiply operations can be issued every other clock cycle. Appropriate interlocks are implemented to stall the issuance of back-to-back 32x32 multiply operations. The multiply operand size is automatically determined by logic built into the MDU.

Divide operations are implemented with a simple 1 bit per clock iterative algorithm. An early-in detection checks the sign extension of the dividend (*rs*) operand. If *rs* is 8 bits wide, 23 iterations are skipped. For a 16 bit wide *rs*, 15 iterations are skipped and for a 24 bit wide *rs*, 7 iterations are skipped. Any attempt to issue a subsequent MDU instruction while a divide is still active causes an IU pipeline stall until the divide operation is completed.

Table 3-1 lists the repeat rate (peak issue rate of cycles until the operation can be reissued) and latency (number of cycles until a result is available) for the PIC32 core multiply and divide instructions. The approximate latency and repeat rates are listed in terms of pipeline clocks.

TABLE 3-1: MIPS® M4K® CORE HIGH-PERFORMANCE INTEGER MULTIPLY/DIVIDE UNIT LATENCIES AND REPEAT RATES

Opcode	Operand Size (mul <i>rt</i>) (div <i>rs</i>)	Latency	Repeat Rate
MULT/MULTU, MADD/MADDU, MSUB/MSUBU	16 bits	1	1
	32 bits	2	2
MUL	16 bits	2	1
	32 bits	3	2
DIV/DIVU	8 bits	12	11
	16 bits	19	18
	24 bits	26	25
	32 bits	33	32

The MIPS architecture defines that the result of a multiply or divide operation be placed in the HI and LO registers. Using the Move-From-HI (MFHI) and Move-From-LO (MFLO) instructions, these values can be transferred to the General Purpose Register file.

In addition to the HI/LO targeted operations, the MIPS32 architecture also defines a multiply instruction, MUL, which places the least significant results in the primary register file instead of the HI/LO register pair. By avoiding the explicit MFLO instruction required when using the LO register, and by supporting multiple destination registers, the throughput of multiply-intensive operations is increased.

Two other instructions, Multiply-Add (MADD) and Multiply-Subtract (MSUB), are used to perform the multiply-accumulate and multiply-subtract operations. The MADD instruction multiplies two numbers and then adds the product to the current contents of the HI and LO registers. Similarly, the MSUB instruction multiplies two operands and then subtracts the product from the HI and LO registers. The MADD and MSUB operations are commonly used in DSP algorithms.

3.2.3 SYSTEM CONTROL COPROCESSOR (CP0)

In the MIPS architecture, CP0 is responsible for the virtual-to-physical address translation, the exception control system, the processor's diagnostics capability, the operating modes (Kernel, User and Debug) and whether interrupts are enabled or disabled. Configuration information, such as presence of options like MIPS16e, is also available by accessing the CP0 registers, listed in [Table 3-2](#).

TABLE 3-2: COPROCESSOR 0 REGISTERS

Register Number	Register Name	Function
0-6	Reserved	Reserved.
7	HWREna	Enables access via the RDHWR instruction to selected hardware registers.
8	BadVAddr ⁽¹⁾	Reports the address for the most recent address-related exception.
9	Count ⁽¹⁾	Processor cycle count.
10	Reserved	Reserved.
11	Compare ⁽¹⁾	Timer interrupt control.
12	Status ⁽¹⁾	Processor status and control.
12	IntCtl ⁽¹⁾	Interrupt system status and control.
12	SRSCtl ⁽¹⁾	Shadow register set status and control.
12	SRSMap ⁽¹⁾	Provides mapping from vectored interrupt to a shadow set.
13	Cause ⁽¹⁾	Cause of last general exception.
14	EPC ⁽¹⁾	Program counter at last exception.
15	PRId	Processor identification and revision.
15	EBASE	Exception vector base register.
16	Config	Configuration register.
16	Config1	Configuration Register 1.
16	Config2	Configuration Register 2.
16	Config3	Configuration Register 3.
17-22	Reserved	Reserved.
23	Debug ⁽²⁾	Debug control and exception status.
24	DEPC ⁽²⁾	Program counter at last debug exception.
25-29	Reserved	Reserved.
30	ErrorEPC ⁽¹⁾	Program counter at last error.
31	DESAVE ⁽²⁾	Debug handler scratchpad register.

Note 1: Registers used in exception processing.

2: Registers used during debug.

Coprocessor 0 also contains the logic for identifying and managing exceptions. Exceptions can be caused by a variety of sources, including alignment errors in data, external events or program errors. [Table 3-3](#) lists the exception types in order of priority.

TABLE 3-3: PIC32MX5XX/6XX/7XX FAMILY CORE EXCEPTION TYPES

Exception	Description
Reset	Assertion $\overline{\text{MCLR}}$ or a Power-on Reset (POR).
DSS	EJTAG debug single step.
DINT	EJTAG debug interrupt. Caused by the assertion of the external <i>EJ_DINT</i> input or by setting the <i>EjtagBrk</i> bit in the ECR register.
NMI	Assertion of NMI signal.
Interrupt	Assertion of unmasked hardware or software interrupt signal.
DIB	EJTAG debug hardware instruction break matched.
AdEL	Fetch address alignment error. Fetch reference to protected address.
IBE	Instruction fetch bus error.
DBp	EJTAG breakpoint (execution of <i>SDBBP</i> instruction).
Sys	Execution of <i>SYSCALL</i> instruction.
Bp	Execution of <i>BREAK</i> instruction.
RI	Execution of a reserved instruction.
CpU	Execution of a coprocessor instruction for a coprocessor that is not enabled.
CEU	Execution of a <i>CorExtend</i> instruction when <i>CorExtend</i> is not enabled.
Ov	Execution of an arithmetic instruction that overflowed.
Tr	Execution of a trap (when trap condition is true).
DDBL/DDBS	EJTAG Data Address Break (address only) or EJTAG data value break on store (address + value).
AdEL	Load address alignment error. Load reference to protected address.
AdES	Store address alignment error. Store to protected address.
DBE	Load or store bus error.
DDBL	EJTAG data hardware breakpoint matched in load data compare.

3.3 Power Management

The MIPS M4K Processor core offers a number of power management features, including low-power design, active power management and power-down modes of operation. The core is a static design that supports slowing or Halting the clocks, which reduces system power consumption during Idle periods.

3.3.1 INSTRUCTION-CONTROLLED POWER MANAGEMENT

The mechanism for invoking Power-Down mode is through execution of the `WAIT` instruction. For more information on power management, see [Section 27.0 “Power-Saving Features”](#).

3.3.2 LOCAL CLOCK GATING

The majority of the power consumed by the PIC32MX5XX/6XX/7XX family core is in the clock tree and clocking registers. The PIC32 family uses extensive use of local gated clocks to reduce this dynamic power consumption.

3.4 EJTAG Debug Support

The MIPS M4K Processor core provides for an Enhanced JTAG (EJTAG) interface for use in the software debug of application and kernel code. In addition to standard User mode and Kernel modes of operation, the MIPS M4K core provides a Debug mode that is entered after a debug exception (derived from a hardware breakpoint, single-step exception, etc.) is taken and continues until a Debug Exception Return (`DERET`) instruction is executed. During this time, the processor executes the debug exception handler routine.

The EJTAG interface operates through the Test Access Port (TAP), a serial communication port used for transferring test data in and out of the MIPS M4K processor core. In addition to the standard JTAG instructions, special instructions defined in the EJTAG specification define which registers are selected and how they are used.

4.0 MEMORY ORGANIZATION

Note: This data sheet summarizes the features of the PIC32MX5XX/6XX/7XX family of devices. It is not intended to be a comprehensive reference source. For detailed information, refer to **Section 3. “Memory Organization”** (DS61115) in the “PIC32 Family Reference Manual”, which is available from the Microchip web site (www.microchip.com/PIC32).

PIC32MX5XX/6XX/7XX microcontrollers provide 4 GB of unified virtual memory address space. All memory regions, including program, data memory, SFRs and Configuration registers, reside in this address space at their respective unique addresses. The program and data memories can be optionally partitioned into user and kernel memories. In addition, the data memory can be made executable, allowing PIC32MX5XX/6XX/7XX devices to execute from data memory.

Key features include:

- 32-bit native data width
- Separate User (KUSEG) and Kernel (KSEG0/KSEG1) mode address space
- Flexible program Flash memory partitioning
- Flexible data RAM partitioning for data and program space
- Separate boot Flash memory for protected code
- Robust bus exception handling to intercept runaway code
- Simple memory mapping with Fixed Mapping Translation (FMT) unit
- Cacheable (KSEG0) and non-cacheable (KSEG1) address regions

4.1 PIC32MX5XX/6XX/7XX Memory Layout

PIC32MX5XX/6XX/7XX microcontrollers implement two address schemes: virtual and physical. All hardware resources, such as program memory, data memory and peripherals, are located at their respective physical addresses. Virtual addresses are exclusively used by the CPU to fetch and execute instructions as well as access peripherals. Physical addresses are used by bus master peripherals, such as DMA and the Flash controller, that access memory independently of the CPU.

The memory maps for the PIC32MX5XX/6XX/7XX devices are illustrated in [Figure 4-1](#) through [Figure 4-6](#).

4.1.1 PERIPHERAL REGISTERS LOCATIONS

[Table 4-1](#) through [Table 4-44](#) contain the peripheral address maps for the PIC32MX5XX/6XX/7XX devices. Peripherals located on the PB bus are mapped to 512-byte boundaries. Peripherals on the FPB bus are mapped to 4-Kbyte boundaries.

PIC32MX5XX/6XX/7XX

FIGURE 4-1: MEMORY MAP ON RESET FOR PIC32MX564F064H, PIC32MX564F064L, PIC32MX664F064H AND PIC32MX664F064L DEVICES⁽¹⁾

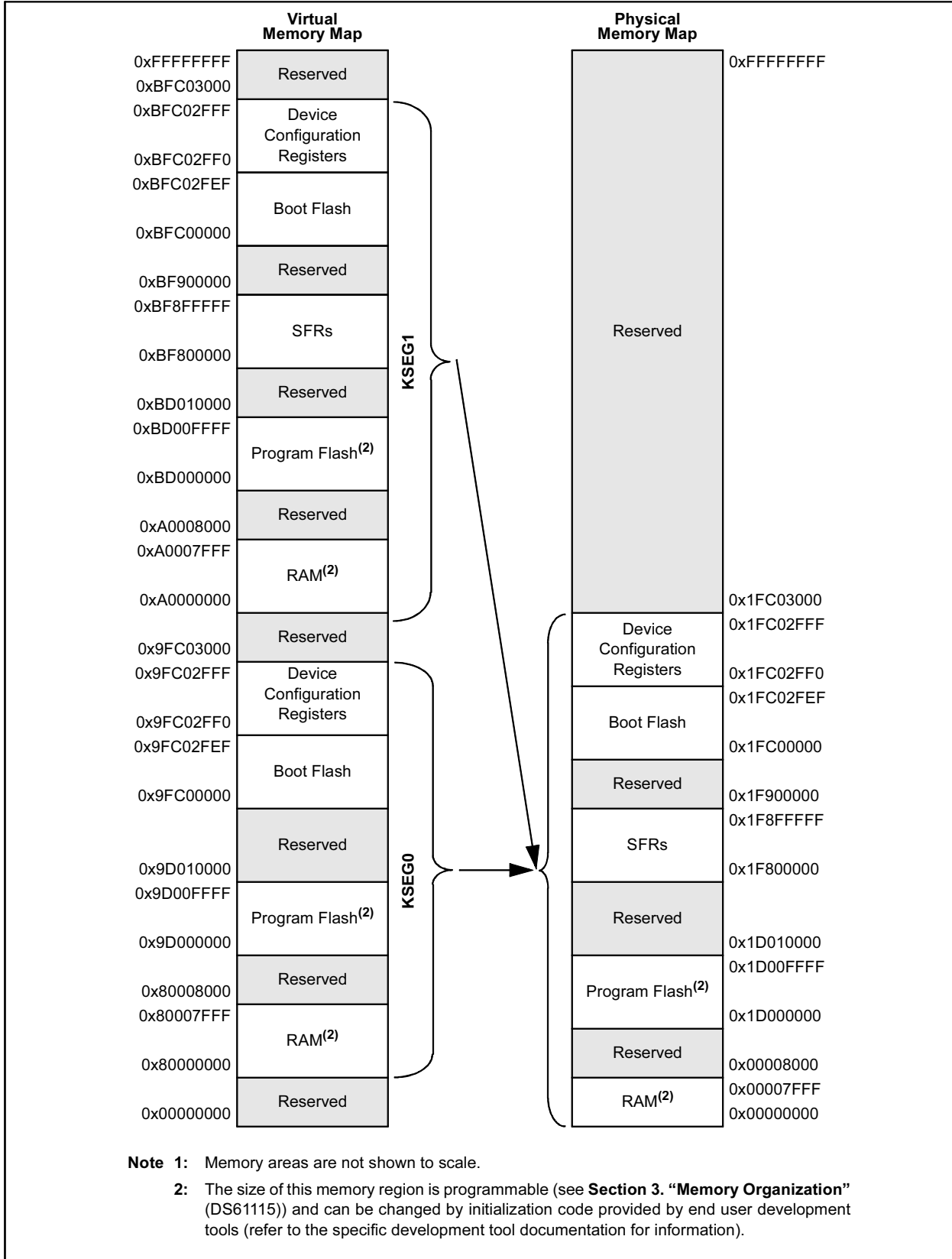
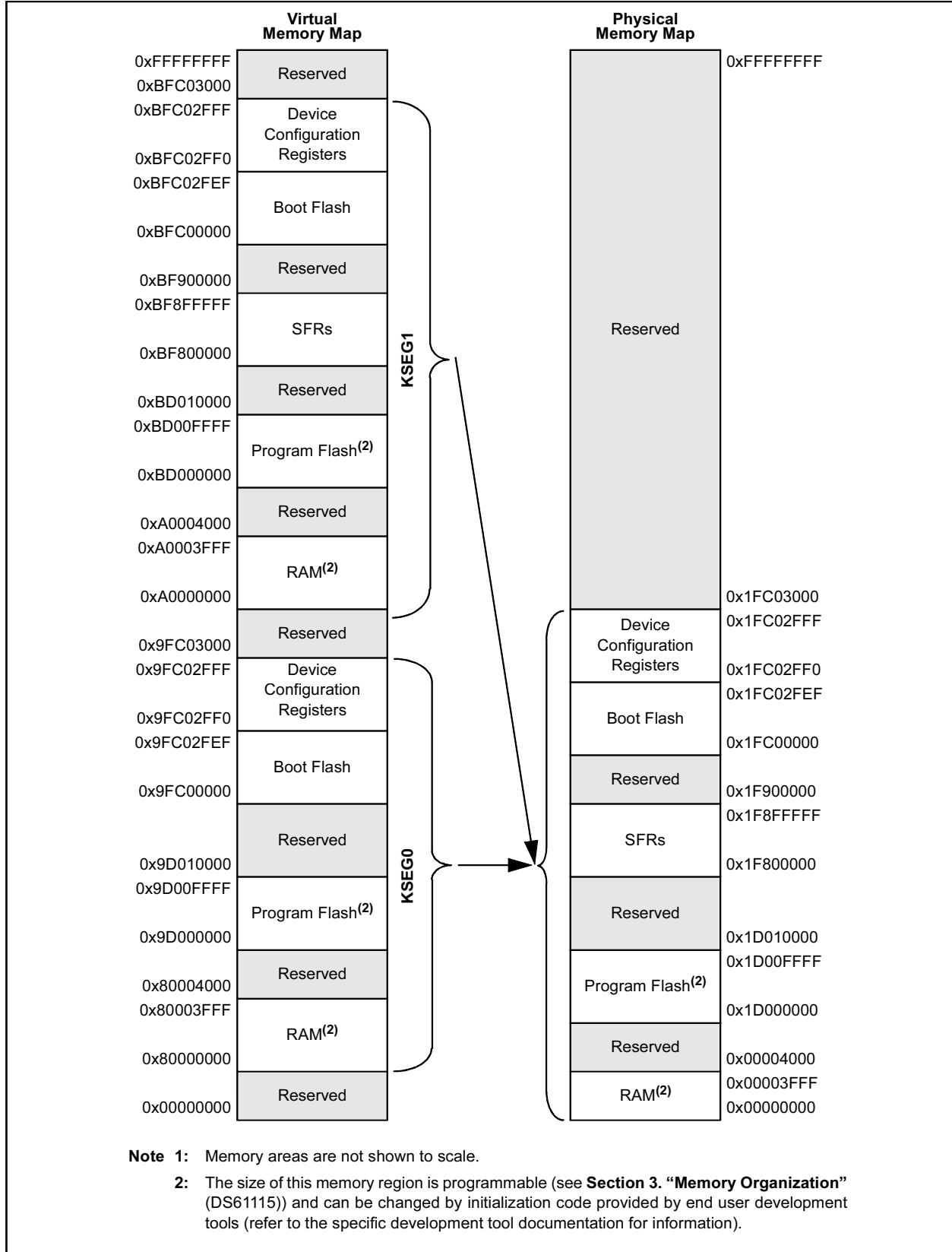

FIGURE 4-2: MEMORY MAP ON RESET FOR PIC32MX534F064H AND PIC32MX534F064L DEVICES⁽¹⁾



PIC32MX5XX/6XX/7XX

FIGURE 4-3: MEMORY MAP ON RESET FOR PIC32MX564F128H, PIC32MX564F128L, PIC32MX664F128H, PIC32MX664F128L, PIC32MX764F128H AND PIC32MX764F128L DEVICES⁽¹⁾

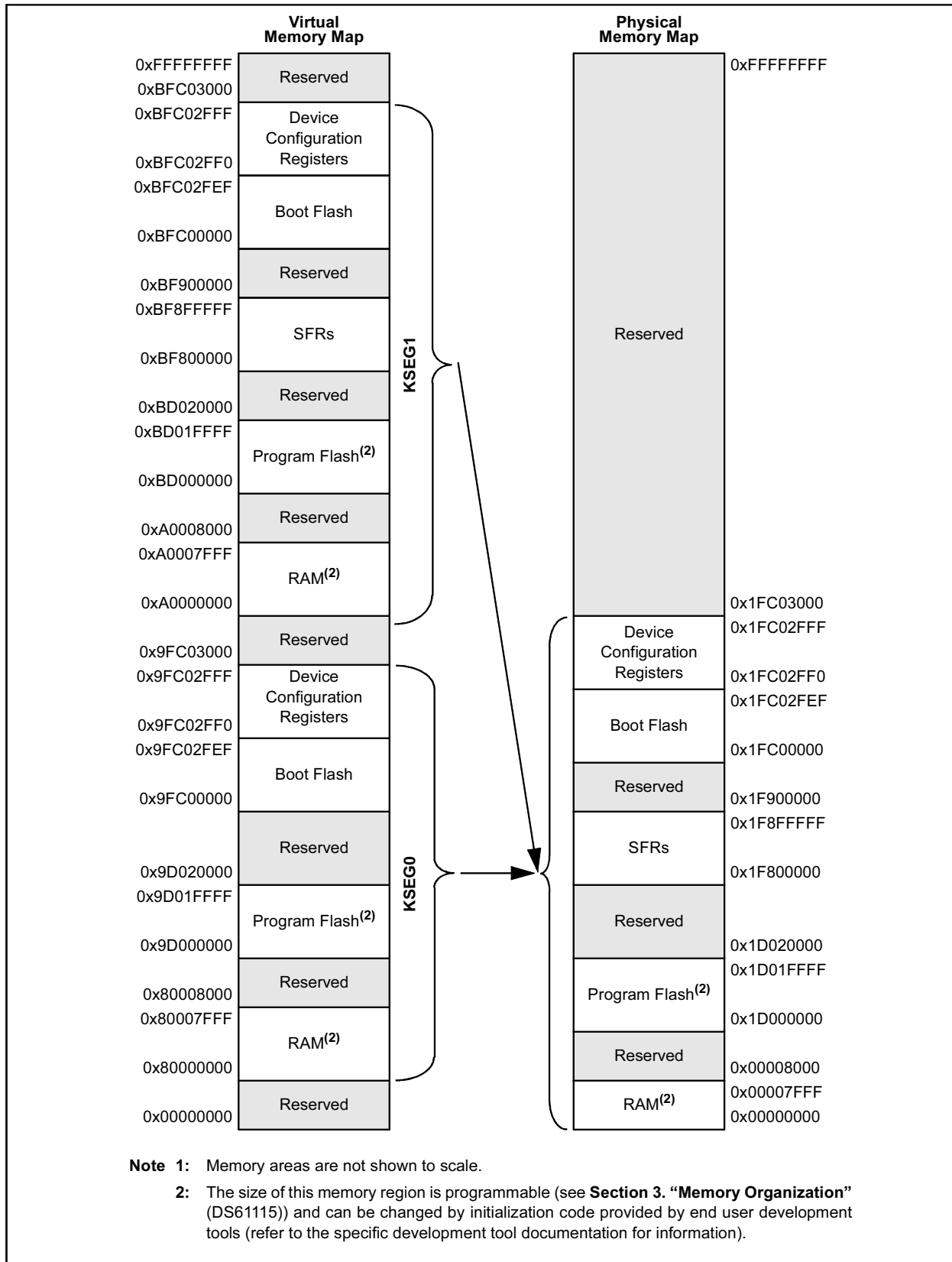
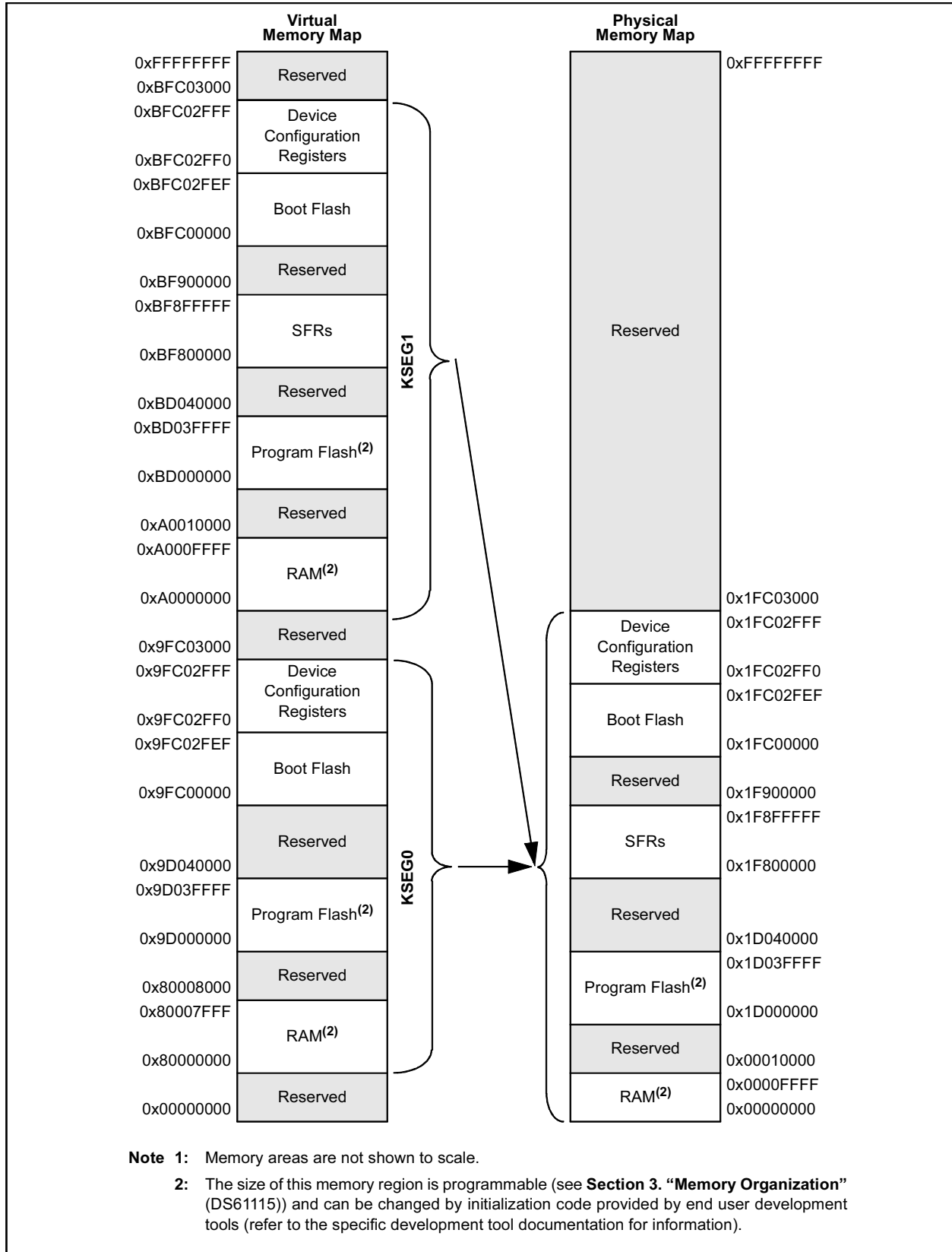

FIGURE 4-4: MEMORY MAP ON RESET FOR PIC32MX575F256H, PIC32MX575F256L, PIC32MX675F256H, PIC32MX675F256L, PIC32MX775F256H AND PIC32MX775F256L DEVICES⁽¹⁾



PIC32MX5XX/6XX/7XX

FIGURE 4-5: MEMORY MAP ON RESET FOR PIC32MX575F512H, PIC32MX575F512L, PIC32MX675F512H, PIC32MX675F512L, PIC32MX775F512H AND PIC32MX775F512L DEVICES

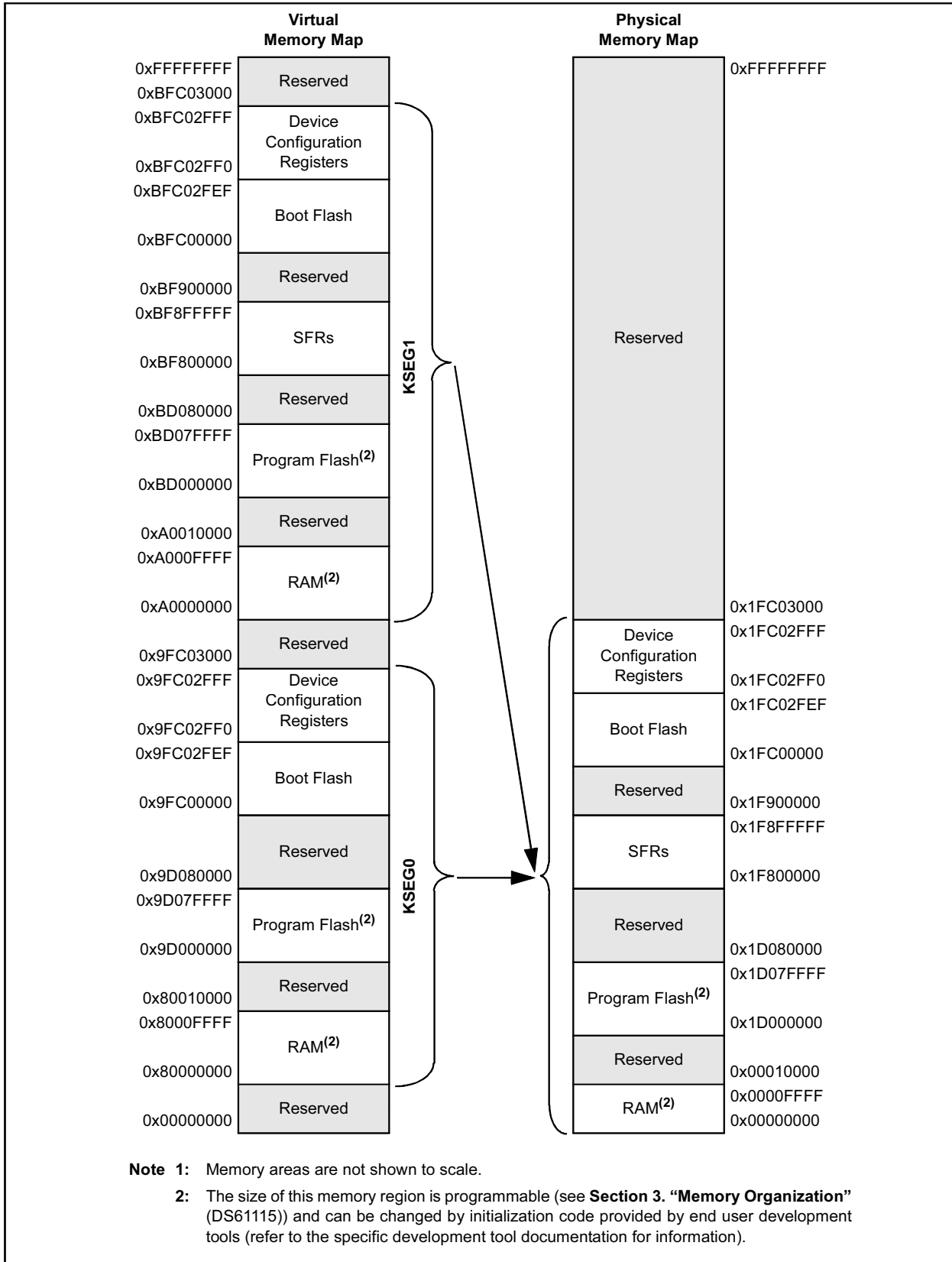

FIGURE 4-6: MEMORY MAP ON RESET FOR PIC32MX695F512H, PIC32MX695F512L, PIC32MX795F512H AND PIC32MX795F512L DEVICES

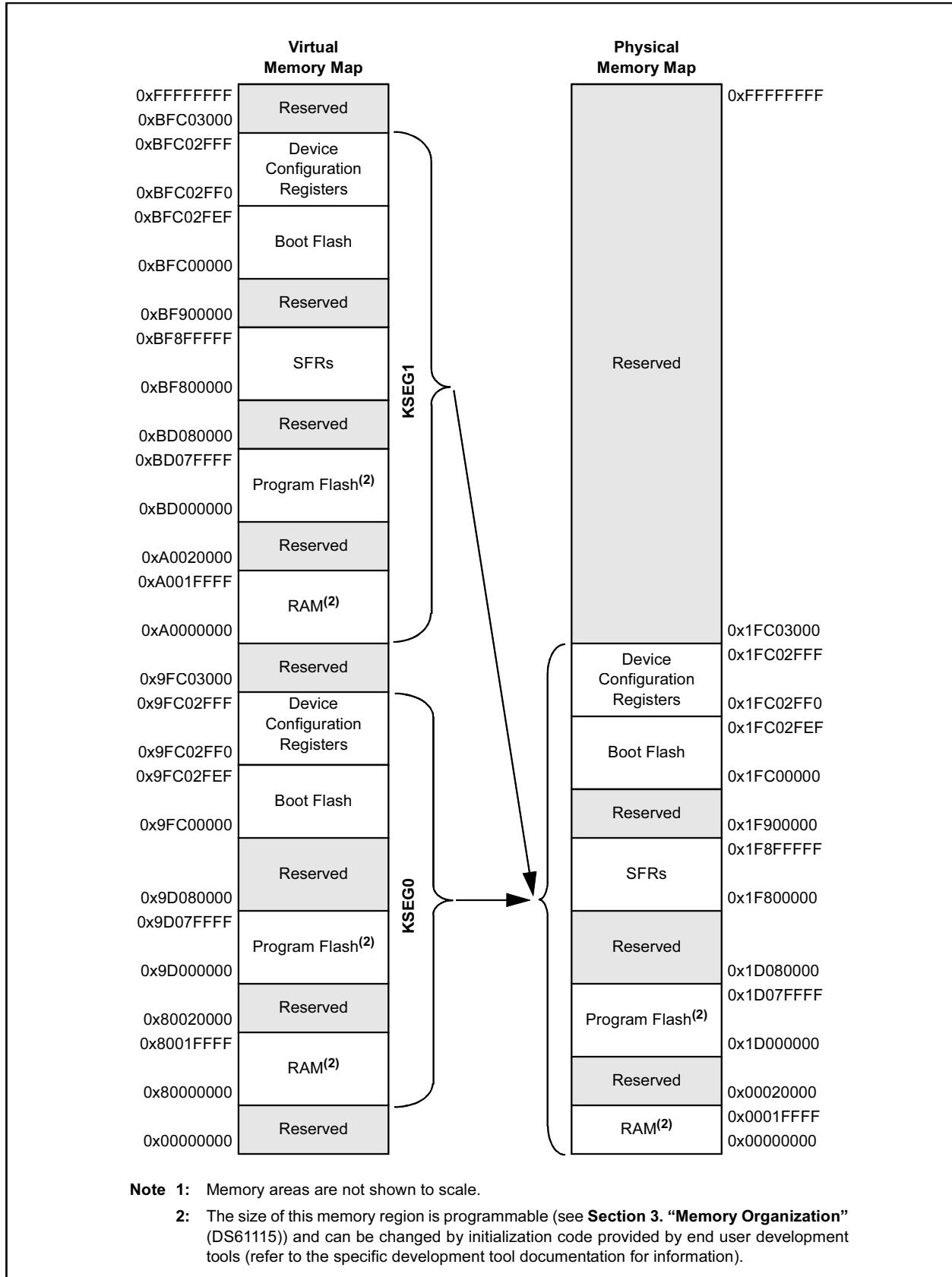

TABLE 4-1: BUS MATRIX REGISTER MAP

Virtual Address (BF88_#)	Register Name	Bit Range	Bits																All Resets	
			31/15	30/14	29/13	28/12	27/11	26/10	25/9	24/8	23/7	22/6	21/5	20/4	19/3	18/2	17/1	16/0		
2000	BMXCON ⁽¹⁾	31:16	—	—	—	—	—	—	—	—	—	—	—	—	—	—	—	—	BMXERRIS	00 1F
		15:0	—	—	—	—	—	—	—	—	—	—	—	—	—	—	—	—	BMXERRDMA	00 41
2010	BMXDKPBA ⁽¹⁾	31:16	—	—	—	—	—	—	—	—	—	—	—	—	—	—	—	—	BMXERRRCD	00 00
		15:0	—	—	—	—	—	—	—	—	—	—	—	—	—	—	—	—	BMXERRRCD	00 00
2020	BMXDUDBA ⁽¹⁾	31:16	—	—	—	—	—	—	—	—	—	—	—	—	—	—	—	—	BMXERRRCD	00 00
		15:0	—	—	—	—	—	—	—	—	—	—	—	—	—	—	—	—	BMXERRRCD	00 00
2030	BMXDUPBA ⁽¹⁾	31:16	—	—	—	—	—	—	—	—	—	—	—	—	—	—	—	—	BMXERRRCD	00 00
		15:0	—	—	—	—	—	—	—	—	—	—	—	—	—	—	—	—	BMXERRRCD	00 00
2040	BMXDRMSZ	31:16	—	—	—	—	—	—	—	—	—	—	—	—	—	—	—	—	BMXERRRCD	00 00
		15:0	—	—	—	—	—	—	—	—	—	—	—	—	—	—	—	—	BMXERRRCD	00 00
2050	BMXPUPBA ⁽¹⁾	31:16	—	—	—	—	—	—	—	—	—	—	—	—	—	—	—	—	BMXERRRCD	00 00
		15:0	—	—	—	—	—	—	—	—	—	—	—	—	—	—	—	—	BMXERRRCD	00 00
2060	BMXPFMSZ	31:16	—	—	—	—	—	—	—	—	—	—	—	—	—	—	—	—	BMXERRRCD	00 00
		15:0	—	—	—	—	—	—	—	—	—	—	—	—	—	—	—	—	BMXERRRCD	00 00
2070	BMXBOOTSZ	31:16	—	—	—	—	—	—	—	—	—	—	—	—	—	—	—	—	BMXERRRCD	00 00
		15:0	—	—	—	—	—	—	—	—	—	—	—	—	—	—	—	—	BMXERRRCD	00 00

Legend: x = unknown value on Reset; — = unimplemented, read as '0'. Reset values are shown in hexadecimal.

Note 1: This register has corresponding CLR, SET and INV registers at its virtual address, plus an offset of 0x4, 0x8 and 0xC, respectively. See [Section 12.1.1 "CLR, SET and INV Registers"](#) for more information.

TABLE 4-2: INTERRUPT REGISTER MAP FOR PIC32MX534F064H, PIC32MX564F064H, PIC32MX564F128H, PIC32MX575F256H AND PIC32MX575F512H DEVICES⁽¹⁾

Virtual Address (BF8 #)	Register Name	Bit Range	Bits																Resets	
			31/15	30/14	29/13	28/12	27/11	26/10	25/9	24/8	23/7	22/6	21/5	20/4	19/3	18/2	17/1	16/0		
1000	INTCON	31:16	—	—	—	—	—	—	—	—	—	—	—	—	—	—	—	SS0	0000	
1010	INTSTAT ⁽³⁾	15:0	—	FRZ	—	MVEC	—	—	—	—	—	—	—	—	INT4EP	INT3EP	INT2EP	INT1EP	INT0EP	0000
		31:16	—	—	—	—	—	—	—	—	—	—	—	—	—	—	—	—	—	—
1020	IPTMR	15:0	—	—	—	—	—	—	—	—	—	—	—	—	—	—	—	—	—	0000
		31:16	—	—	—	—	—	—	—	—	—	—	—	—	—	—	—	—	—	—
1030	IFS0	31:16	I2C1MIF	I2C1SIF	I2C1BIF	U1TXIF SPI3TXIF I2C3MIF	U1RXIF SPI3RXIF I2C3SIF	U1EIF SPI3EIF I2C3BIF	—	—	—	OC5IF	IC5IF	T5IF	INT4IF	OC4IF	IC4IF	T4IF	—	0000
			INT3IF	OC3IF	IC3IF	T3IF	INT2IF	OC2IF	IC2IF	USBIF	INT1IF	OC1IF	IC1IF	T1IF	INT0IF	CS1IF	CS0IF	CTIF	—	0000
			IC3EIF	IC2EIF	IC1EIF	—	—	CAN1IF U2TXIF SPI4TXIF I2C5MIF	CAN1IF U2RXIF SPI4RXIF I2C5SIF	U2EIF U3RXIF SPI2TXIF I2C4BIF	DMA7IF ⁽²⁾ U3TXIF SPI2TXIF I2C4MIF	DMA6IF ⁽²⁾ U3RXIF SPI2RXIF I2C4SIF	DMA5IF ⁽²⁾ U3EIF	DMA4IF ⁽²⁾ CMP2IF	DMA3IF	DMA2IF	DMA1IF	DMA0IF	—	0000
1040	IFS1	15:0	RTCCIF	FSCMIF	—	—	—	—	—	—	—	—	—	—	—	—	—	—	—	0000
			—	—	—	—	—	—	—	—	—	—	—	—	—	—	—	—	—	—
1050	IFS2	31:16	—	—	—	—	—	—	—	—	—	—	—	—	—	—	—	—	—	0000
		15:0	—	—	—	—	—	—	—	—	—	—	—	—	—	—	—	—	—	0000
1060	IEC0	31:16	I2C1MIE	I2C1SIE	I2C1BIE	U1TXIE SPI3TXIE I2C3MIE	U1RXIE SPI3RXIE I2C3SIE	U1EIE SPI3EIE I2C3BIE	—	—	—	OC5IE	IC5IE	T5IE	INT4IE	OC4IE	IC4IE	T4IE	—	0000
			INT3IE	OC3IE	IC3IE	T3IE	INT2IE	OC2IE	IC2IE	USBIE	INT1IE	OC1IE	IC1IE	T1IE	INT0IE	CS1IE	CS0IE	CTIE	—	0000
			IC3EIE	IC2EIE	IC1EIE	—	—	CAN1IE U2TXIE SPI4TXIE I2C5MIE	CAN1IE U2RXIE SPI4RXIE I2C5SIE	U2EIE U3RXIE SPI2TXIE I2C4BIE	DMA7IE ⁽²⁾ U3TXIE SPI2TXIE I2C4MIE	DMA6IE ⁽²⁾ U3RXIE SPI2RXIE I2C4SIE	DMA5IE ⁽²⁾ U3EIE	DMA4IE ⁽²⁾ CMP2IE	DMA3IE	DMA2IE	DMA1IE	DMA0IE	—	0000
1070	IEC1	15:0	RTCCIE	FSCMIE	—	—	—	—	—	—	—	—	—	—	—	—	—	—	—	0000
			—	—	—	—	—	—	—	—	—	—	—	—	—	—	—	—	—	—
1080	IEC2	31:16	—	—	—	—	—	—	—	—	—	—	—	—	—	—	—	—	—	0000
		15:0	—	—	—	—	—	—	—	—	—	—	—	—	—	—	—	—	—	0000
1090	IPC0	31:16	—	—	—	—	—	—	—	—	—	—	—	—	—	—	—	—	—	0000
		15:0	—	—	—	—	—	—	—	—	—	—	—	—	—	—	—	—	—	0000
10A0	IPC1	31:16	—	—	—	—	—	—	—	—	—	—	—	—	—	—	—	—	—	0000
		15:0	—	—	—	—	—	—	—	—	—	—	—	—	—	—	—	—	—	0000

Legend: x = unknown value on Reset; — = unimplemented, read as '0'. Reset values are shown in hexadecimal.

Note 1: Except where noted, all registers in this table have corresponding CLR, SET and INV registers at their virtual addresses, plus offsets of 0x4 0x8 and 0xC, respectively. See [Section 12.1.1 "CLR, SET and INV Registers"](#) for more information.

2: These bits are not available on PIC32MX534/564/664/764 devices.

3: This register does not have associated CLR, SET, and INV registers.

TABLE 4-2: INTERRUPT REGISTER MAP FOR PIC32MX534F064H, PIC32MX564F064H, PIC32MX564F128H, PIC32MX575F256H AND PIC32MX575F512H DEVICES⁽¹⁾ (CONTINUED)

Virtual Address (BF8 _h)	Register Name	Bit Range	Bits																Resets All	
			31/15	30/14	29/13	28/12	27/11	26/10	25/9	24/8	23/7	22/6	21/5	20/4	19/3	18/2	17/1	16/0		
10B0	IPC2	31:16	—	—	—	—	INT2IP<2:0>	—	—	—	—	—	—	—	—	—	—	—	OC2IS<1:0>	0000
		15:0	—	—	—	—	IC2IP<2:0>	—	—	—	—	—	—	—	—	—	—	—	T2IS<1:0>	0000
10C0	IPC3	31:16	—	—	—	—	INT3IP<2:0>	—	—	—	—	—	—	—	—	—	—	—	OC3IS<1:0>	0000
		15:0	—	—	—	—	IC3IP<2:0>	—	—	—	—	—	—	—	—	—	—	—	T3IS<1:0>	0000
10D0	IPC4	31:16	—	—	—	—	INT4IP<2:0>	—	—	—	—	—	—	—	—	—	—	—	OC4IS<1:0>	0000
		15:0	—	—	—	—	IC4IP<2:0>	—	—	—	—	—	—	—	—	—	—	—	T4IS<1:0>	0000
10E0	IPC5	31:16	—	—	—	—	—	—	—	—	—	—	—	—	—	—	—	—	OC5IS<1:0>	0000
		15:0	—	—	—	—	IC5IP<2:0>	—	—	—	—	—	—	—	—	—	—	—	T5IS<1:0>	0000
		31:16	—	—	—	—	AD1IP<2:0>	—	—	—	—	—	—	—	—	—	—	—	CNIS<1:0>	0000
10F0	IPC6	15:0	—	—	—	—	—	—	—	—	—	—	—	—	—	—	—	—	U1IS<1:0>	0000
			—	—	—	—	—	—	—	—	—	—	—	—	—	—	—	—	SPI3IS<1:0>	0000
			—	—	—	—	—	—	—	—	—	—	—	—	—	—	—	—	I2C3IS<1:0>	0000
1100	IPC7	31:16	—	—	—	—	—	—	—	—	—	—	—	—	—	—	—	—	CMP2IS<1:0>	0000
			—	—	—	—	—	—	—	—	—	—	—	—	—	—	—	—	—	—
			—	—	—	—	—	—	—	—	—	—	—	—	—	—	—	—	—	—
1110	IPC8	15:0	—	—	—	—	—	—	—	—	—	—	—	—	—	—	—	—	—	0000
			—	—	—	—	—	—	—	—	—	—	—	—	—	—	—	—	—	—
			—	—	—	—	—	—	—	—	—	—	—	—	—	—	—	—	—	—
1120	IPC9	31:16	—	—	—	—	—	—	—	—	—	—	—	—	—	—	—	—	—	0000
		15:0	—	—	—	—	—	—	—	—	—	—	—	—	—	—	—	—	—	0000
1130	IPC10	31:16	—	—	—	—	—	—	—	—	—	—	—	—	—	—	—	—	—	0000
		15:0	—	—	—	—	—	—	—	—	—	—	—	—	—	—	—	—	—	0000
1140	IPC11	31:16	—	—	—	—	—	—	—	—	—	—	—	—	—	—	—	—	—	0000
		15:0	—	—	—	—	—	—	—	—	—	—	—	—	—	—	—	—	—	0000
1150	IPC12	31:16	—	—	—	—	—	—	—	—	—	—	—	—	—	—	—	—	—	0000
		15:0	—	—	—	—	—	—	—	—	—	—	—	—	—	—	—	—	—	0000

Legend: x = unknown value on Reset; — = unimplemented, read as '0'. Reset values are shown in hexadecimal.

Note 1: Except where noted, all registers in this table have corresponding CLR, SET and INV registers at their virtual addresses, plus offsets of 0x4 0x8 and 0xC, respectively. See [Section 12.1.1 “CLR, SET and INV Registers”](#) for more information.

2: These bits are not available on PIC32MX534/564/664/764 devices.

3: This register does not have associated CLR, SET, and INV registers.

TABLE 4-3: INTERRUPT REGISTER MAP FOR PIC32MX664F064H, PIC32MX664F128H, PIC32MX675F256H, PIC32MX675F512H AND PIC32MX695F512H DEVICES⁽¹⁾

Virtual Address (BF8 #)	Register Name	Bit Range	Bits																All Resets		
			31/15	30/14	29/13	28/12	27/11	26/10	25/9	24/8	23/7	22/6	21/5	20/4	19/3	18/2	17/1	16/0			
1000	INTCON	31:16	—	—	—	—	—	—	—	—	—	—	—	—	—	—	—	—	SS0	0000	
		15:0	—	FRZ	—	MVEC	—	—	—	—	—	—	—	—	—	—	—	—	INT1EP	INT0EP	0000
1010	INTSTAT ⁽²⁾	31:16	—	—	—	—	—	—	—	—	—	—	—	—	—	—	—	—	—	—	0000
		15:0	—	—	—	—	—	—	—	—	—	—	—	—	—	—	—	—	—	—	0000
1020	IPTMR	31:16	—	—	—	—	—	—	—	—	—	—	—	—	—	—	—	—	—	—	0000
		15:0	—	—	—	—	—	—	—	—	—	—	—	—	—	—	—	—	—	—	0000
1030	IFS0	31:16	I2C1MIF	I2C1SIF	I2C1BIF	U1TXIF SPI3RXIF I2C3MIF	U1RXIF SPI3RXIF I2C3SIF	U1EIF SPI3EIF I2C3BIF	—	—	—	—	—	—	—	—	—	—	—	—	0000
		15:0	INT3IF	OC3IF	IC3IF	T3IF	INT2IF	OC2IF	IC2IF	USBIF	FCEIF	T2IF	INT1IF	OC1IF	IC1IF	T1IF	INT0IF	CS0IF	DMA0IF	DMA0IF	0000
1040	IFS1	15:0	RTCCIF	FSCMIF	—	—	—	—	—	—	—	—	—	—	—	—	—	—	—	—	0000
		31:16	—	—	—	—	—	—	—	—	—	—	—	—	—	—	—	—	—	—	0000
1050	IFS2	15:0	—	—	—	—	—	—	—	—	—	—	—	—	—	—	—	—	—	—	0000
		31:16	—	—	—	—	—	—	—	—	—	—	—	—	—	—	—	—	—	—	0000
1060	IEC0	31:16	I2C1MIE	I2C1SIE	I2C1BIE	U1TXIE SPI3TXIE I2C3MIE	U1RXIE SPI3RXIE I2C3SIE	U1EIE SPI3EIE I2C3BIE	—	—	—	—	—	—	—	—	—	—	—	—	0000
		15:0	INT3IE	OC3IE	IC3IE	T3IE	INT2IE	OC2IE	IC2IE	USBIE	FCEIE	T2IE	INT1IE	OC1IE	IC1IE	T1IE	INT0IE	CS0IE	DMA0IE	DMA0IE	0000
1070	IEC1	15:0	RTCCIE	FSCMIE	—	—	—	—	—	—	—	—	—	—	—	—	—	—	—	—	0000
		31:16	—	—	—	—	—	—	—	—	—	—	—	—	—	—	—	—	—	—	0000
1080	IEC2	15:0	—	—	—	—	—	—	—	—	—	—	—	—	—	—	—	—	—	—	0000
		31:16	—	—	—	—	—	—	—	—	—	—	—	—	—	—	—	—	—	—	0000
1090	IPC0	15:0	—	—	—	—	—	—	—	—	—	—	—	—	—	—	—	—	—	—	0000
		31:16	—	—	—	—	—	—	—	—	—	—	—	—	—	—	—	—	—	—	0000
10A0	IPC1	15:0	—	—	—	—	—	—	—	—	—	—	—	—	—	—	—	—	—	—	0000
		31:16	—	—	—	—	—	—	—	—	—	—	—	—	—	—	—	—	—	—	0000
10B0	IPC2	15:0	—	—	—	—	—	—	—	—	—	—	—	—	—	—	—	—	—	—	0000
		31:16	—	—	—	—	—	—	—	—	—	—	—	—	—	—	—	—	—	—	0000
10C0	IPC3	15:0	—	—	—	—	—	—	—	—	—	—	—	—	—	—	—	—	—	—	0000
		31:16	—	—	—	—	—	—	—	—	—	—	—	—	—	—	—	—	—	—	0000

Legend: x = unknown value on Reset; — = unimplemented, read as '0'. Reset values are shown in hexadecimal.

- Note 1:** Except where noted, all registers in this table have corresponding CLR, SET, and INV registers at their virtual addresses, plus offsets of 0x4, 0x8 and 0xC respectively. See [Section 12.1.1 "CLR, SET and INV Registers"](#) for more information.
- Note 2:** These bits are not available on PIC32MX664 devices.
- Note 3:** This register does not have associated CLR, SET, and INV registers.

TABLE 4-3: INTERRUPT REGISTER MAP FOR PIC32MX664F064H, PIC32MX664F128H, PIC32MX675F256H, PIC32MX675F512H AND PIC32MX695F512H DEVICES⁽¹⁾ (CONTINUED)

Virtual Address (BF8 #)	Register Name	Bit Range	Bits																All Resets		
			31/15	30/14	29/13	28/12	27/11	26/10	25/9	24/8	23/7	22/6	21/5	20/4	19/3	18/2	17/1	16/0			
10D0	IPC4	31:16	—	—	—	—	INT4IP<2:0> IC4IP<2:0>	—	—	INT4IS<1:0> IC4IS<1:0>	—	—	—	—	—	—	—	—	OC4IP<2:0> T4IP<2:0>	OC4IS<1:0> T4IS<1:0>	0000
10E0	IPC5	31:16	—	—	—	—	—	—	—	—	—	—	—	—	—	—	—	—	OC5IP<2:0> T5IP<2:0>	OC5IS<1:0> T5IS<1:0>	0000
10F0	IPC6	31:16	—	—	—	—	—	—	—	—	—	—	—	—	—	—	—	—	OC6IP<2:0> T6IP<2:0>	OC6IS<1:0> T6IS<1:0>	0000
1100	IPC7	31:16	—	—	—	—	—	—	—	—	—	—	—	—	—	—	—	—	OC7IP<2:0> T7IP<2:0>	OC7IS<1:0> T7IS<1:0>	0000
1110	IPC8	31:16	—	—	—	—	—	—	—	—	—	—	—	—	—	—	—	—	OC8IP<2:0> T8IP<2:0>	OC8IS<1:0> T8IS<1:0>	0000
1120	IPC9	31:16	—	—	—	—	—	—	—	—	—	—	—	—	—	—	—	—	OC9IP<2:0> T9IP<2:0>	OC9IS<1:0> T9IS<1:0>	0000
1130	IPC10	31:16	—	—	—	—	—	—	—	—	—	—	—	—	—	—	—	—	OC10IP<2:0> T10IP<2:0>	OC10IS<1:0> T10IS<1:0>	0000
1140	IPC11	31:16	—	—	—	—	—	—	—	—	—	—	—	—	—	—	—	—	OC11IP<2:0> T11IP<2:0>	OC11IS<1:0> T11IS<1:0>	0000
1150	IPC12	31:16	—	—	—	—	—	—	—	—	—	—	—	—	—	—	—	—	OC12IP<2:0> T12IP<2:0>	OC12IS<1:0> T12IS<1:0>	0000

Legend: x = unknown value on Reset; — = unimplemented; read as '0'. Reset values are shown in hexadecimal.

- Note 1:** Except where noted, all registers in this table have corresponding CLR, SET and INV registers at their virtual addresses, plus offsets of 0x4, 0x8 and 0xC respectively. See [Section 12.1.1 "CLR, SET and INV Registers"](#) for more information.
- Note 2:** These bits are not available on PIC32MX664 devices.
- Note 3:** This register does not have associated CLR, SET, and INV registers.

TABLE 4-4: INTERRUPT REGISTER MAP FOR PIC32MX764F128H, PIC32MX775F256H, PIC32MX775F512H AND PIC32MX795F512H DEVICES⁽¹⁾

Virtual Address (BF8 #)	Register Name	Bit Range	Bits																All Resets
			31/15	30/14	29/13	28/12	27/11	26/10	25/9	24/8	23/7	22/6	21/5	20/4	19/3	18/2	17/1	16/0	
1000	INTCON	31:16	—	—	—	—	—	—	—	—	—	—	—	—	—	—	—	SS0	0000
		15:0	FRZ	—	—	MVEC	—	—	—	TPC<2:0>	—	—	—	—	—	—	—	INT0EP	0000
1010	INTSTAT ⁽³⁾	31:16	—	—	—	—	—	—	—	—	—	—	—	—	—	—	—	—	0000
		15:0	—	—	—	—	—	—	—	—	—	—	—	—	—	—	—	—	0000
1020	IPTMR	31:16	—	—	—	—	—	—	—	—	—	—	—	—	—	—	—	—	0000
		15:0	—	—	—	—	—	—	—	—	—	—	—	—	—	—	—	—	0000
1030	IFS0	31:16	I2C1MIF	I2C1SIF	I2C1BIF	U1TXIF SPI3TXIF I2C3MIF	U1RXIF SPI3RXIF I2C3SIF	U1EIF SPI3EIF I2C3BIF	—	—	—	—	—	—	—	—	—	—	0000
		15:0	INT3IF	OC3IF	IC3IF	T3IF	INT2IF	OC2IF	IC2IF	INT1IF	T2IF	FCEIF	U2EIF	OC1IF	IC1IF	T1IF	INT0IF	CS0IF	0000
1040	IFS1	31:16	IC3EIF	I2C2EIF	IC1EIF	ETHIF	CAN2IF ⁽²⁾	CAN1IF	U5BIF	DMA7IF ⁽²⁾	DMA6IF ⁽²⁾	DMA5IF ⁽²⁾	U3RXIF	DMA3IF	DMA2IF	DMA1IF	DMA0IF	DMA0IF	0000
		15:0	RTCCIF	FSCMIF	—	—	—	—	—	—	—	—	—	—	—	—	—	—	0000
1050	IFS2	31:16	—	—	—	—	—	—	—	—	—	—	—	—	—	—	—	—	0000
		15:0	—	—	—	—	—	—	—	—	—	—	—	—	—	—	—	—	0000
1060	IEC0	31:16	I2C1MIE	I2C1SIE	I2C1BIE	U1TXIE SPI3TXIE I2C3MIE	U1RXIE SPI3RXIE I2C3SIE	U1EIE SPI3EIE I2C3BIE	—	—	—	—	—	—	—	—	—	—	0000
		15:0	INT3IE	OC3IE	IC3IE	T3IE	INT2IE	OC2IE	IC2IE	INT1IE	T2IE	FCEIE	U2EIE	OC1IE	IC1IE	T1IE	INT0IE	CS0IE	0000
1070	IEC1	31:16	IC3EIE	IC2EIE	IC1EIE	ETHIE	CAN2IE ⁽²⁾	CAN1IE	U5BIE	DMA7IE ⁽²⁾	DMA6IE ⁽²⁾	DMA5IE ⁽²⁾	U3RXIE	DMA3IE	DMA2IE	DMA1IE	DMA0IE	DMA0IE	0000
		15:0	RTCCIE	FSCMIE	—	—	—	—	—	—	—	—	—	—	—	—	—	—	0000
1080	IEC2	31:16	—	—	—	—	—	—	—	—	—	—	—	—	—	—	—	—	0000
		15:0	—	—	—	—	—	—	—	—	—	—	—	—	—	—	—	—	0000
1090	IPC0	31:16	INT0IP<2:0>	INT0IS<1:0>	—	—	—	—	—	—	—	—	—	—	—	—	—	—	0000
		15:0	—	—	—	—	—	—	—	—	—	—	—	—	—	—	—	—	0000
10A0	IPC1	31:16	INT1IP<2:0>	INT1IS<1:0>	—	—	—	—	—	—	—	—	—	—	—	—	—	—	0000
		15:0	—	—	—	—	—	—	—	—	—	—	—	—	—	—	—	—	0000
10B0	IPC2	31:16	INT2IP<2:0>	INT2IS<1:0>	—	—	—	—	—	—	—	—	—	—	—	—	—	—	0000
		15:0	—	—	—	—	—	—	—	—	—	—	—	—	—	—	—	—	0000
10C0	IPC3	31:16	INT3IP<2:0>	INT3IS<1:0>	—	—	—	—	—	—	—	—	—	—	—	—	—	—	0000
		15:0	—	—	—	—	—	—	—	—	—	—	—	—	—	—	—	—	0000

Legend: x = unknown value on Reset; — = unimplemented; read as '0'. Reset values are shown in hexadecimal.

- Note 1: Except where noted, all registers in this table have corresponding CLR, SET and INV registers at their virtual addresses, plus offsets of 0x4, 0x8 and 0xC, respectively. See Section 12.1.1 "CLR, SET and INV Registers" for more information.
- Note 2: This bit is unimplemented on PIC32MX764F128H device.
- Note 3: This register does not have associated CLR, SET, and INV registers.

TABLE 4-4: INTERRUPT REGISTER MAP FOR PIC32MX764F128H, PIC32MX775F256H, PIC32MX775F512H AND PIC32MX795F512H DEVICES⁽¹⁾ (CONTINUED)

Virtual Address (BF8 #)	Register Name	Bit Range	Bits																All Resets		
			31/15	30/14	29/13	28/12	27/11	26/10	25/9	24/8	23/7	22/6	21/5	20/4	19/3	18/2	17/1	16/0			
10D0	IPC4	31:16	—	—	—	—	INT4IP<2:0>	—	INT4IS<1:0>	—	—	—	—	—	—	—	—	OC4IP<2:0>	OC4IS<1:0>	0000	
10E0	IPC5	15:0	—	—	—	—	IC4IP<2:0>	—	IC4IS<1:0>	—	—	—	—	—	—	—	—	T4IP<2:0>	T4IS<1:0>	0000	
		31:16	—	—	—	—	IC5IP<2:0>	—	IC5IS<1:0>	—	—	—	—	—	—	—	—	OC5IP<2:0>	OC5IS<1:0>	0000	
10F0	IPC6	15:0	—	—	—	—	AD1IP<2:0>	—	AD1IS<1:0>	—	—	—	—	—	—	—	—	—	—	—	0000
		31:16	—	—	—	—	I2C1IP<2:0>	—	I2C1IS<1:0>	—	—	—	—	—	—	—	—	U1IP<2:0>	U1IS<1:0>	0000	
1100	IPC7	31:16	—	—	—	—	U3IP<2:0>	—	U3IS<1:0>	—	—	—	—	—	—	—	—	—	—	—	0000
			—	—	—	—	SPI2IP<2:0>	—	SPI2IS<1:0>	—	—	—	—	—	—	—	—	—	—	—	0000
			—	—	—	—	I2C4IP<2:0>	—	I2C4IS<1:0>	—	—	—	—	—	—	—	—	—	—	—	0000
1110	IPC8	15:0	—	—	—	—	CMP1IP<2:0>	—	CMP1IS<1:0>	—	—	—	—	—	—	—	—	—	—	—	0000
			31:16	—	—	—	RTCC1IP<2:0>	—	RTCC1IS<1:0>	—	—	—	—	—	—	—	—	—	—	—	0000
1120	IPC9	15:0	—	—	—	—	—	—	—	—	—	—	—	—	—	—	—	—	—	—	0000
			—	—	—	—	—	—	—	—	—	—	—	—	—	—	—	—	—	—	0000
			—	—	—	—	—	—	—	—	—	—	—	—	—	—	—	—	—	—	0000
1130	IPC10	15:0	—	—	—	—	—	—	—	—	—	—	—	—	—	—	—	—	—	—	0000
			31:16	—	—	—	—	—	—	—	—	—	—	—	—	—	—	—	—	—	—
1140	IPC11	15:0	—	—	—	—	—	—	—	—	—	—	—	—	—	—	—	—	—	—	0000
			31:16	—	—	—	—	—	—	—	—	—	—	—	—	—	—	—	—	—	—
1150	IPC12	15:0	—	—	—	—	—	—	—	—	—	—	—	—	—	—	—	—	—	—	0000
			31:16	—	—	—	—	—	—	—	—	—	—	—	—	—	—	—	—	—	—

Legend: x = unknown value on Reset; — = unimplemented, read as '0'. Reset values are shown in hexadecimal.

- Note 1:** Except where noted, all registers in this table have corresponding CLR, SET and INV registers at their virtual addresses, plus offsets of 0x4, 0x8 and 0xC, respectively. See [Section 12.1.1 "CLR, SET and INV Registers"](#) for more information.
- 2:** This bit is unimplemented on PIC32MX764F128H device.
- 3:** This register does not have associated CLR, SET, and INV registers.

TABLE 4-5: INTERRUPT REGISTER MAP FOR PIC32MX534F064L, PIC32MX564F064L, PIC32MX564F128L, PIC32MX575F512L AND PIC32MX575F256L DEVICES⁽¹⁾

Virtual Address (BF8 #)	Register Name	Bit Range	Bits																All Resets					
			31/15	30/14	29/13	28/12	27/11	26/10	25/9	24/8	23/7	22/6	21/5	20/4	19/3	18/2	17/1	16/0						
1000	INTCON	31:16	—	—	—	—	—	—	—	—	—	—	—	—	—	—	—	SS0	0000					
		15:0	FRZ	—	—	MVEC	—	—	—	—	—	—	—	—	—	—	—	INT4EP	INT3EP	INT2EP	INT1EP	INT0EP	0000	
1010	INTSTAT ⁽³⁾	31:16	—	—	—	—	—	—	—	—	—	—	—	—	—	—	—	—	—	—	—	—	—	0000
		15:0	—	—	—	—	—	—	—	—	—	—	—	—	—	—	—	—	—	—	—	—	—	0000
1020	PTMR	31:16	—	—	—	—	—	—	—	—	—	—	—	—	—	—	—	—	—	—	—	—	—	0000
		15:0	—	—	—	—	—	—	—	—	—	—	—	—	—	—	—	—	—	—	—	—	—	0000
1030	IFS0	31:16	I2C1MIF	I2C1SIF	I2C1BIF	U1TXIF	U1RXIF	U1RXIF	U1EIF	U1EIF	SP1TXIF	SP1RXIF	SP1EIF	OC5IF	IC5IF	T5IF	INT4IF	OC4IF	IC4IF	IC4IF	T4IF	T4IF	0000	
		15:0	INT3IF	OC3IF	IC3IF	IC3IF	IC3IF	IC3IF	IC3IF	IC3IF	IC3IF	IC3IF	IC3IF	IC3IF	IC3IF	IC3IF	IC3IF	IC3IF	IC3IF	IC3IF	IC3IF	IC3IF	0000	
1040	IFS1	15:0	IC3EIF	IC2EIF	IC1EIF	T3IF	—	—	—	—	—	—	—	—	—	—	—	—	—	—	—	—	0000	
		31:16	RTCCIF	FSCMIF	I2C2MIF	I2C2SIF	I2C2BIF	I2C2BIF	SP4TXIF	SP4RXIF	I2C5SIF	I2C5BIF	I2C4MIF	I2C4SIF	I2C4BIF	CMP2IF	CMP1IF	PMPIF	AD1IF	AD1IF	CNIF	CNIF	0000	
1050	IFS2	31:16	—	—	—	—	—	—	—	—	—	—	—	—	—	—	—	—	—	—	—	—	0000	
		15:0	—	—	—	—	—	—	—	—	—	—	—	—	—	—	—	—	—	—	—	—	0000	
1060	IEC0	31:16	I2C1MIE	I2C1SIE	I2C1BIE	U1TXIE	U1RXIE	U1RXIE	U1EIE	U1EIE	SP1TXIE	SP1RXIE	SP1EIE	OC5IE	IC5IE	T5IE	INT4IE	OC4IE	IC4IE	IC4IE	T4IE	T4IE	0000	
		15:0	INT3IE	OC3IE	IC3IE	IC3IE	IC3IE	IC3IE	IC3IE	IC3IE	IC3IE	IC3IE	IC3IE	IC3IE	IC3IE	IC3IE	IC3IE	IC3IE	IC3IE	IC3IE	IC3IE	IC3IE	0000	
1070	IEC1	31:16	IC3EIE	IC2EIE	IC1EIE	T3IE	—	—	—	—	—	—	—	—	—	—	—	—	—	—	—	—	0000	
		15:0	RTCCIE	FSCMIE	I2C2MIE	I2C2SIE	I2C2BIE	I2C2BIE	SP4TXIE	SP4RXIE	I2C5SIE	I2C5BIE	I2C4MIE	I2C4SIE	I2C4BIE	CMP2IE	CMP1IE	PMPIE	AD1IE	AD1IE	CNIE	CNIE	0000	
1080	IEC2	31:16	—	—	—	—	—	—	—	—	—	—	—	—	—	—	—	—	—	—	—	—	0000	
		15:0	—	—	—	—	—	—	—	—	—	—	—	—	—	—	—	—	—	—	—	—	0000	
1090	IPC0	31:16	INT0IP<2:0>	INT0IP<2:0>	INT0IP<1:0>	INT0IS<1:0>	INT0IS<1:0>	INT0IS<1:0>	INT0IS<1:0>	INT0IS<1:0>	INT0IS<1:0>	INT0IS<1:0>	INT0IS<1:0>	INT0IS<1:0>	INT0IS<1:0>	INT0IS<1:0>	INT0IS<1:0>	INT0IS<1:0>	INT0IS<1:0>	INT0IS<1:0>	INT0IS<1:0>	INT0IS<1:0>	0000	
		15:0	CS0IP<2:0>	CS0IP<2:0>	CS0IS<1:0>	CS0IS<1:0>	CS0IS<1:0>	CS0IS<1:0>	CS0IS<1:0>	CS0IS<1:0>	CS0IS<1:0>	CS0IS<1:0>	CS0IS<1:0>	CS0IS<1:0>	CS0IS<1:0>	CS0IS<1:0>	CS0IS<1:0>	CS0IS<1:0>	CS0IS<1:0>	CS0IS<1:0>	CS0IS<1:0>	CS0IS<1:0>	0000	
10A0	IPC1	31:16	INT1IP<2:0>	INT1IP<2:0>	INT1IP<1:0>	INT1IS<1:0>	INT1IS<1:0>	INT1IS<1:0>	INT1IS<1:0>	INT1IS<1:0>	INT1IS<1:0>	INT1IS<1:0>	INT1IS<1:0>	INT1IS<1:0>	INT1IS<1:0>	INT1IS<1:0>	INT1IS<1:0>	INT1IS<1:0>	INT1IS<1:0>	INT1IS<1:0>	INT1IS<1:0>	INT1IS<1:0>	0000	
		15:0	IC1IP<2:0>	IC1IP<2:0>	IC1IS<1:0>	IC1IS<1:0>	IC1IS<1:0>	IC1IS<1:0>	IC1IS<1:0>	IC1IS<1:0>	IC1IS<1:0>	IC1IS<1:0>	IC1IS<1:0>	IC1IS<1:0>	IC1IS<1:0>	IC1IS<1:0>	IC1IS<1:0>	IC1IS<1:0>	IC1IS<1:0>	IC1IS<1:0>	IC1IS<1:0>	IC1IS<1:0>	0000	
10B0	IPC2	31:16	INT2IP<2:0>	INT2IP<2:0>	INT2IP<1:0>	INT2IS<1:0>	INT2IS<1:0>	INT2IS<1:0>	INT2IS<1:0>	INT2IS<1:0>	INT2IS<1:0>	INT2IS<1:0>	INT2IS<1:0>	INT2IS<1:0>	INT2IS<1:0>	INT2IS<1:0>	INT2IS<1:0>	INT2IS<1:0>	INT2IS<1:0>	INT2IS<1:0>	INT2IS<1:0>	INT2IS<1:0>	0000	
		15:0	IC2IP<2:0>	IC2IP<2:0>	IC2IS<1:0>	IC2IS<1:0>	IC2IS<1:0>	IC2IS<1:0>	IC2IS<1:0>	IC2IS<1:0>	IC2IS<1:0>	IC2IS<1:0>	IC2IS<1:0>	IC2IS<1:0>	IC2IS<1:0>	IC2IS<1:0>	IC2IS<1:0>	IC2IS<1:0>	IC2IS<1:0>	IC2IS<1:0>	IC2IS<1:0>	IC2IS<1:0>	0000	
10C0	IPC3	31:16	INT3IP<2:0>	INT3IP<2:0>	INT3IP<1:0>	INT3IS<1:0>	INT3IS<1:0>	INT3IS<1:0>	INT3IS<1:0>	INT3IS<1:0>	INT3IS<1:0>	INT3IS<1:0>	INT3IS<1:0>	INT3IS<1:0>	INT3IS<1:0>	INT3IS<1:0>	INT3IS<1:0>	INT3IS<1:0>	INT3IS<1:0>	INT3IS<1:0>	INT3IS<1:0>	INT3IS<1:0>	0000	
		15:0	IC3IP<2:0>	IC3IP<2:0>	IC3IS<1:0>	IC3IS<1:0>	IC3IS<1:0>	IC3IS<1:0>	IC3IS<1:0>	IC3IS<1:0>	IC3IS<1:0>	IC3IS<1:0>	IC3IS<1:0>	IC3IS<1:0>	IC3IS<1:0>	IC3IS<1:0>	IC3IS<1:0>	IC3IS<1:0>	IC3IS<1:0>	IC3IS<1:0>	IC3IS<1:0>	IC3IS<1:0>	0000	

Legend: x = unknown value on Reset; — = unimplemented, read as '0'. Reset values are shown in hexadecimal.

- Note 1: Except where noted, all registers in this table have corresponding CLR, SET and INV registers at their virtual addresses, plus offsets of 0x4, 0x8 and 0xC, respectively. See Section 12.1.1 "CLR, SET and INV Registers" for more information.
- Note 2: These bits are not available on PIC32MX534/564 devices.
- Note 3: This register does not have associated CLR, SET, and INV registers.

TABLE 4-5: INTERRUPT REGISTER MAP FOR PIC32MX534F064L, PIC32MX564F064L, PIC32MX564F128L PIC32MX575F512L AND PIC32MX575F256L DEVICES⁽¹⁾ (CONTINUED)

Virtual Address (BF8 #)	Register Name	Bit Range	Bits																All Resets	
			31/15	30/14	29/13	28/12	27/11	26/10	25/9	24/8	23/7	22/6	21/5	20/4	19/3	18/2	17/1	16/0		
10D0	IPC4	31:16 15:0	—	—	—	INT4IP<2:0>	INT4IS<1:0>	—	—	—	—	—	—	—	—	—	—	—	OC4IS<1:0>	0000
10E0	IPC5	31:16 15:0	—	—	—	IC4IP<2:0>	IC4IS<1:0>	—	—	—	—	—	—	—	—	—	—	—	T4IS<1:0>	0000
10F0	IPC6	31:16 15:0	—	—	—	SPI1IP<2:0>	SPI1IS<1:0>	—	—	—	—	—	—	—	—	—	—	—	OC5IS<1:0>	0000
		31:16	—	—	—	IC5IP<2:0>	IC5IS<1:0>	—	—	—	—	—	—	—	—	—	—	—	T5IS<1:0>	0000
		31:16	—	—	—	AD1IP<2:0>	AD1IS<1:0>	—	—	—	—	—	—	—	—	—	—	—	CN1S<1:0>	0000
		15:0	—	—	—	I2C1IP<2:0>	I2C1IS<1:0>	—	—	—	—	—	—	—	—	—	—	—	U1IS<1:0>	0000
		31:16	—	—	—	U3IP<2:0>	U3IS<1:0>	—	—	—	—	—	—	—	—	—	—	—	SPI3IS<1:0>	0000
		31:16	—	—	—	SPI2IP<2:0>	SPI2IS<1:0>	—	—	—	—	—	—	—	—	—	—	—	I2C3IS<1:0>	0000
		15:0	—	—	—	I2C4IP<2:0>	I2C4IS<1:0>	—	—	—	—	—	—	—	—	—	—	—	CMP2IS<1:0>	0000
		31:16	—	—	—	CMP1IP<2:0>	CMP1IS<1:0>	—	—	—	—	—	—	—	—	—	—	—	PMP1P<2:0>	0000
		15:0	—	—	—	RTCCIP<2:0>	RTCCIS<1:0>	—	—	—	—	—	—	—	—	—	—	—	FSCMIP<1:0>	0000
		15:0	—	—	—	I2C2IP<2:0>	I2C2IS<1:0>	—	—	—	—	—	—	—	—	—	—	—	U2IP<2:0>	0000
		31:16	—	—	—	DMA3IP<2:0>	DMA3IS<1:0>	—	—	—	—	—	—	—	—	—	—	—	DMA2IP<2:0>	0000
		15:0	—	—	—	DMA1IP<2:0>	DMA1IS<1:0>	—	—	—	—	—	—	—	—	—	—	—	DMA0IS<1:0>	0000
		31:16	—	—	—	DMA7IP<2:0> ⁽²⁾	DMA7IS<1:0> ⁽²⁾	—	—	—	—	—	—	—	—	—	—	—	DMA6IS<1:0> ⁽²⁾	0000
		15:0	—	—	—	DMA5IP<2:0> ⁽²⁾	DMA5IS<1:0> ⁽²⁾	—	—	—	—	—	—	—	—	—	—	—	DMA4IP<2:0> ⁽²⁾	0000
		31:16	—	—	—	—	—	—	—	—	—	—	—	—	—	—	—	—	CAN1IS<1:0>	0000
		15:0	—	—	—	USBIP<2:0>	USBIS<1:0>	—	—	—	—	—	—	—	—	—	—	—	FCEIP<1:0>	0000
		31:16	—	—	—	U5IP<2:0>	U5IS<1:0>	—	—	—	—	—	—	—	—	—	—	—	U6IS<1:0>	0000
		15:0	—	—	—	U4IP<2:0>	U4IS<1:0>	—	—	—	—	—	—	—	—	—	—	—	—	0000

Legend: x = unknown value on Reset; — = unimplemented, read as '0'. Reset values are shown in hexadecimal.

Note 1: Except where noted, all registers in this table have corresponding CLR, SET and INV registers at their virtual addresses, plus offsets of 0x4, 0x8 and 0xC, respectively. See [Section 12.1.1 "CLR, SET and INV Registers"](#) for more information.

2: These bits are not available on PIC32MX534/564 devices.

3: This register does not have associated CLR, SET, and INV registers.

TABLE 4-6: INTERRUPT REGISTER MAP FOR PIC32MX664F064L, PIC32MX664F128L, PIC32MX675F256L, PIC32MX675F512L AND PIC32MX695F512L DEVICES⁽¹⁾

Virtual Address (BF8 #)	Register Name	Bit Range	Bits																All Resets
			31/15	30/14	29/13	28/12	27/11	26/10	25/9	24/8	23/7	22/6	21/5	20/4	19/3	18/2	17/1	16/0	
1000	INTCON	31:16	—	—	—	—	—	—	—	—	—	—	—	—	—	—	—	SS0	0000
		15:0	—	FRZ	—	MVEC	—	—	—	TPC<2:0>	—	—	—	INT4EP	INT3EP	INT2EP	INT1EP	INT0EP	0000
1010	INTSTAT ⁽²⁾	31:16	—	—	—	—	—	—	—	—	—	—	—	—	—	—	—	—	0000
		15:0	—	—	—	—	—	—	—	SRPL<2:0>	—	—	—	—	—	—	—	VEC<5:0>	0000
1020	IPTMR	31:16	—	—	—	—	—	—	—	—	—	—	—	—	—	—	—	—	0000
		15:0	—	—	—	—	—	—	—	—	—	—	—	—	—	—	—	—	0000
1030	IFS0	31:16	I2C1MIF	I2C1SIF	I2C1BIF	U1TXIF SPI3TXIF I2C3MIF	U1RXIF SPI3RXIF I2C3SIF	U1EIF SPI3EIF I2C3BIF	SP11TXIF	SP11RXIF	SP11EIF	OC5IF	IC5IF	T5IF	INT4IF	OC4IF	IC4IF	T4IF	0000
		15:0	INT3IF	OC3IF	IC3IF	T3IF	INT2IF	OC2IF	IC2IF	T2IF	INT1IF	OC1IF	IC1IF	T1IF	INT0IF	CS0IF	CTIF	0000	
		31:16	IC3EIF	IC2EIF	IC1EIF	ETHIF	—	—	USBIF	FCEIF	DMA7IF ⁽²⁾	DMA6IF ⁽²⁾	DMA5IF ⁽²⁾	DMA4IF ⁽²⁾	DMA3IF	DMA2IF	DMA1IF	DMA0IF	0000
1040	IFS1	15:0	RTCCIF	FSCMIF	I2C2MIF	I2C2SIF	I2C2BIF	U2TXIF SPI4TXIF I2C5MIF	U2RXIF SPI4RXIF I2C5SIF	U2EIF SPI4EIF I2C5BIF	U2EIF SPI2TXIF I2C4MIF	U3RXIF SPI2RXIF I2C4SIF	U3EIF SPI2EIF I2C4BIF	CMP2IF	PMPIF	AD1IF	CNIF	0000	
1050	IFS2	31:16	—	—	—	—	—	—	—	—	—	—	—	—	—	—	—	—	0000
		15:0	—	—	—	—	—	—	U5TXIF	U6TXIF	U6RXIF	U6EIF	U4TXIF	U4RXIF	PMPEIF	IC5EIF	IC4EIF	0000	
		31:16	I2C1MIE	I2C1SIE	I2C1BIE	U1TXIE SPI3TXIE I2C3MIE	U1RXIE SPI3RXIE I2C3SIE	U1EIE SPI3EIE I2C3BIE	SP11TXIE	SP11RXIE	SP11EIE	OC5IE	IC5IE	T5IE	INT4IE	OC4IE	IC4IE	T4IE	0000
		15:0	INT3IE	OC3IE	IC3IE	T3IE	INT2IE	OC2IE	IC2IE	T2IE	INT1IE	OC1IE	IC1IE	T1IE	INT0IE	CS0IE	CTIE	0000	
		31:16	IC3EIE	IC2EIE	IC1EIE	ETHIE	—	—	USBIE	FCEIE	DMA7IE ⁽²⁾	DMA6IE ⁽²⁾	DMA5IE ⁽²⁾	DMA4IE ⁽²⁾	DMA3IE	DMA2IE	DMA1IE	DMA0IE	0000
1070	IEC1	15:0	RTCCIE	FSCMIE	I2C2MIE	I2C2SIE	I2C2BIE	U2TXIE SPI4TXIE I2C5MIE	U2RXIE SPI4RXIE I2C5SIE	U2EIE SPI4EIE I2C5BIE	U3TXIE SPI2TXIE I2C4MIE	U3RXIE SPI2RXIE I2C4SIE	U3EIE SPI2EIE I2C4BIE	CMP2IE	PMPIE	AD1IE	CNIE	0000	
1080	IEC2	31:16	—	—	—	—	—	—	—	—	—	—	—	—	—	—	—	—	0000
		15:0	—	—	—	—	—	—	U5TXIE	U6TXIE	U6RXIE	U6EIE	U4TXIE	U4RXIE	PMPEIE	IC5EIE	IC4EIE	0000	
1090	IPC0	31:16	—	—	—	—	—	—	INT0IS<1:0>	INT0IS<1:0>	—	—	—	—	CS1IP<2:0>	CS1IS<1:0>	—	0000	
		15:0	—	—	—	—	—	—	CS0IS<1:0>	CS0IS<1:0>	—	—	—	—	CTIP<2:0>	CTIS<1:0>	—	0000	
10A0	IPC1	31:16	—	—	—	—	—	—	INT1IS<1:0>	INT1IS<1:0>	—	—	—	—	OC1IP<2:0>	OC1IS<1:0>	—	0000	
		15:0	—	—	—	—	—	—	IC1IP<2:0>	IC1IS<1:0>	—	—	—	—	T1IP<2:0>	T1IS<1:0>	—	0000	
10B0	IPC2	31:16	—	—	—	—	—	—	INT2IS<1:0>	INT2IS<1:0>	—	—	—	—	OC2IP<2:0>	OC2IS<1:0>	—	0000	
		15:0	—	—	—	—	—	—	IC2IP<2:0>	IC2IS<1:0>	—	—	—	—	T2IP<2:0>	T2IS<1:0>	—	0000	
10C0	IPC3	31:16	—	—	—	—	—	—	INT3IS<1:0>	INT3IS<1:0>	—	—	—	—	OC3IP<2:0>	OC3IS<1:0>	—	0000	
		15:0	—	—	—	—	—	—	IC3IP<2:0>	IC3IS<1:0>	—	—	—	—	T3IP<2:0>	T3IS<1:0>	—	0000	

Legend: x = unknown value on Reset; — = unimplemented; read as '0'. Reset values are shown in hexadecimal.

Note 1: Except where noted, all registers in this table have corresponding CLR, SET and INV registers at their virtual addresses, plus offsets of 0x4, 0x8 and 0xC, respectively. See [Section 12.1.1 "CLR, SET and INV Registers"](#) for more information.

2: These bits are not available on PIC32MX664 devices.

3: This register does not have associated CLR, SET, and INV registers.

TABLE 4-6: INTERRUPT REGISTER MAP FOR PIC32MX664F064L, PIC32MX664F128L, PIC32MX664F128L, PIC32MX675F256L, PIC32MX675F512L AND PIC32MX695F512L DEVICES⁽¹⁾ (CONTINUED)

Virtual Address (BF88 #)	Register Name	Bit Range	Bits													All Resets				
			31/15	30/14	29/13	28/12	27/11	26/10	25/9	24/8	23/7	22/6	21/5	20/4	19/3		18/2	17/1	16/0	
10D0	IPC4	31:16	—	—	—	INT4IP<2:0>	—	INT4IS<1:0>	—	—	—	—	—	—	—	—	OC4IP<2:0>	OC4IS<1:0>	0000	
		15:0	—	—	—	IC4IP<2:0>	—	IC4IS<1:0>	—	—	—	—	—	—	—	—	T4IP<2:0>	T4IS<1:0>	0000	
10E0	IPC5	31:16	—	—	—	SPI1IP<2:0>	—	SPI1IS<1:0>	—	—	—	—	—	—	—	—	OC5IP<2:0>	OC5IS<1:0>	0000	
		15:0	—	—	—	IC5IP<2:0>	—	IC5IS<1:0>	—	—	—	—	—	—	—	—	T5IP<2:0>	T5IS<1:0>	0000	
10F0	IPC6	31:16	—	—	—	AD1IP<2:0>	—	AD1IS<1:0>	—	—	—	—	—	—	—	—	CNIP<2:0>	CNIS<1:0>	0000	
		15:0	—	—	—	I2C1IP<2:0>	—	I2C1IS<1:0>	—	—	—	—	—	—	—	—	U1IP<2:0>	U1IS<1:0>	0000	
																	SPI3IP<2:0>	SPI3IS<1:0>	0000	
1100	IPC7	31:16	—	—	—	U3IP<2:0>	—	U3IS<1:0>	—	—	—	—	—	—	—	—	I2C3IP<2:0>	I2C3IS<1:0>	0000	
																				0000
																				0000
1100	IPC7	31:16	—	—	—	SPI2IP<2:0>	—	SPI2IS<1:0>	—	—	—	—	—	—	—	—	CMP2IP<2:0>	CMP2IS<1:0>	0000	
																				0000
																				0000
1100	IPC7	31:16	—	—	—	I2C4IP<2:0>	—	I2C4IS<1:0>	—	—	—	—	—	—	—	—	PMPIP<2:0>	PMPIIS<1:0>	0000	
																	FSCMIP<2:0>	FSCMIS<1:0>	0000	
																	U2IP<2:0>	U2IS<1:0>	0000	
1100	IPC8	31:16	—	—	—	CMP1IP<2:0>	—	CMP1IS<1:0>	—	—	—	—	—	—	—	—	SPI4IP<2:0>	SPI4IS<1:0>	0000	
																	I2C5IP<2:0>	I2C5IS<1:0>	0000	
																				0000
1100	IPC8	15:0	—	—	—	I2C2IP<2:0>	—	I2C2IS<1:0>	—	—	—	—	—	—	—	—	DMA2IP<2:0>	DMA2IS<1:0>	0000	
																				0000
																				0000
1100	IPC8	15:0	—	—	—	DMA3IP<2:0>	—	DMA3IS<1:0>	—	—	—	—	—	—	—	—	DMA0IP<2:0>	DMA0IS<1:0>	0000	
																				0000
																				0000
1100	IPC9	31:16	—	—	—	DMA1IP<2:0>	—	DMA1IS<1:0>	—	—	—	—	—	—	—	—	DMA6IP<2:0> ⁽²⁾	DMA6IS<1:0> ⁽²⁾	0000	
																				0000
																				0000
1100	IPC10	31:16	—	—	—	DMA7IP<2:0> ⁽²⁾	—	DMA7IS<1:0> ⁽²⁾	—	—	—	—	—	—	—	—	DMA4IP<2:0> ⁽²⁾	DMA4IS<1:0> ⁽²⁾	0000	
																				0000
																				0000
1140	IPC11	31:16	—	—	—	DMA5IP<2:0> ⁽²⁾	—	DMA5IS<1:0> ⁽²⁾	—	—	—	—	—	—	—	—	—	—	—	0000
																				0000
																				0000
1150	IPC12	31:16	—	—	—	USBIP<2:0>	—	USBIS<1:0>	—	—	—	—	—	—	—	—	FCEIP<2:0>	FCEIS<1:0>	0000	
																				0000
																				0000
1150	IPC12	15:0	—	—	—	U5IP<2:0>	—	U5IS<1:0>	—	—	—	—	—	—	—	—	U6IP<2:0>	U6IS<1:0>	0000	
																				0000
																				0000
																				0000
																				0000

Legend: x = unknown value on Reset; — = unimplemented, read as '0'. Reset values are shown in hexadecimal.

- Note 1:** Except where noted, all registers in this table have corresponding CLR, SET and INV registers at their virtual addresses, plus offsets of 0x4, 0x8 and 0xC, respectively. See [Section 12.1.1 "CLR, SET and INV Registers"](#) for more information.
- 2:** These bits are not available on PIC32MX664 devices.
- 3:** This register does not have associated CLR, SET, and INV registers.

TABLE 4-7: INTERRUPT REGISTER MAP FOR PIC32MX764F128L, PIC32MX775F256L, PIC32MX775F512L AND PIC32MX795F512L DEVICES⁽¹⁾

Virtual Address (BF8 #)	Register Name	Bit Range	Bits																All Resets
			31/15	30/14	29/13	28/12	27/11	26/10	25/9	24/8	23/7	22/6	21/5	20/4	19/3	18/2	17/1	16/0	
1000	INTCON	31:16	—	—	—	—	—	—	—	—	—	—	—	—	—	—	—	SSO	0000
		15:0	—	FRZ	—	MVEC	—	—	—	TPC<2:0>	—	—	—	INT4EP	INT3EP	INT2EP	INT1EP	INT0EP	0000
1010	INTSTAT ⁽³⁾	31:16	—	—	—	—	—	—	—	—	—	—	—	—	—	—	—	—	0000
		15:0	—	—	—	—	—	—	—	SRIPL<2:0>	—	—	—	—	—	—	—	—	0000
1020	IPTMR	31:16	—	—	—	—	—	—	—	—	—	—	—	—	—	—	—	—	0000
		15:0	—	—	—	—	—	—	—	—	—	—	—	—	—	—	—	—	0000
1030	IFS0	31:16	I2C1MIF	I2C1SIF	I2C1BIF	U1TXIF SPI3RXIF I2C3MIF	U1RXIF SPI3RXIF I2C3SIF	U1EIF SPI3EIF I2C3BIF	SP1TXIF	SP1RXIF	SP1EIF	OC5IF	IC5IF	T5IF	INT4IF	OC4IF	IC4IF	T4IF	0000
		15:0	INT3IF	OC3IF	IC3IF	T3IF	INT2IF	OC2IF	IC2IF	T2IF	INT1IF	OC1IF	IC1IF	T1IF	INT0IF	CS0IF	CTIF	0000	
		31:16	IC3EIF	I2C2EIF	IC1EIF	ETHIF	CAN2IF ⁽²⁾	CAN1IF	USBIF	FCEIF	DMA7IF ⁽²⁾	DMA6IF ⁽²⁾	DMA5IF ⁽²⁾	DMA4IF ⁽²⁾	DMA3IF	DMA2IF	DMA1IF	DMA0IF	0000
1040	IFS1	15:0	RTCCIF	FSCMIF	I2C2MIF	I2C2SIF	I2C2BIF	U2TXIF SPI4TXIF I2C5MIF	U2RXIF SPI4RXIF I2C5SIF	U2EIF SPI4EIF I2C5BIF	SP12TXIF SPI2RXIF I2C4MIF	SP12RXIF SPI2RXIE I2C4SIF	SP12EIF SPI2EIF I2C4BIF	CMP2IF	CMP1IF	PMP1IF	AD1IF	CN1F	0000
		31:16	—	—	—	—	—	—	—	—	—	—	—	—	—	—	—	—	0000
		15:0	—	—	—	—	—	—	—	—	—	—	—	—	—	—	—	—	0000
1060	IEC0	31:16	I2C1MIE	I2C1SIE	I2C1BIE	U1TXIE SPI3TXIE I2C3MIE	U1RXIE SPI3RXIE I2C3SIE	U1EIE SPI3EIE I2C3BIE	SP11TXIE	SP11RXIE	SP11EIE	OC5IE	IC5IE	T5IE	INT4IE	OC4IE	IC4IE	T4IE	0000
		15:0	INT3IE	OC3IE	IC3IE	T3IE	INT2IE	OC2IE	IC2IE	T2IE	INT1IE	OC1IE	IC1IE	T1IE	INT0IE	CS0IE	CTIE	0000	
		31:16	IC3EIE	I2C2EIE	IC1EIE	ETHIE	CAN2IE ⁽²⁾	CAN1IE	USBIE	FCEIE	DMA7IE ⁽²⁾	DMA6IE ⁽²⁾	DMA5IE ⁽²⁾	DMA4IE ⁽²⁾	DMA3IE	DMA2IE	DMA1IE	DMA0IE	0000
1070	IEC1	15:0	RTCCIE	FSCMIE	I2C2MIE	I2C2SIE	I2C2BIE	U2TXIE SPI4TXIE I2C5MIE	U2RXIE SPI4RXIE I2C5SIE	U2EIE SPI4EIE I2C5BIE	SP12TXIE SPI2RXIE I2C4MIE	SP12RXIE SPI2RXIE I2C4SIE	SP12EIE SPI2EIE I2C4BIE	CMP2IE	CMP1IE	PMP1IE	AD1IE	CN1IE	0000
		31:16	—	—	—	—	—	—	—	—	—	—	—	—	—	—	—	—	0000
		15:0	—	—	—	—	—	—	—	—	—	—	—	—	—	—	—	—	0000
1080	IEC2	31:16	—	—	—	—	—	—	—	—	—	—	—	—	—	—	—	—	0000
		15:0	—	—	—	—	—	—	—	—	—	—	—	—	—	—	—	—	0000
1090	IPC0	31:16	—	—	—	—	—	—	INT0IP<2:0>	INT0IS<1:0>	—	—	—	—	CS1IP<2:0>	CS1IS<1:0>	—	—	0000
		15:0	—	—	—	—	—	—	CS0IP<2:0>	CS0IS<1:0>	—	—	—	—	CTIP<2:0>	CTIS<1:0>	—	—	0000
10A0	IPC1	31:16	—	—	—	—	—	—	INT1IP<2:0>	INT1IS<1:0>	—	—	—	—	OC1IP<2:0>	OC1IS<1:0>	—	—	0000
		15:0	—	—	—	—	—	—	IC1IP<2:0>	IC1IS<1:0>	—	—	—	—	T1IP<2:0>	T1IS<1:0>	—	—	0000
10B0	IPC2	31:16	—	—	—	—	—	—	INT2IP<2:0>	INT2IS<1:0>	—	—	—	—	OC2IP<2:0>	OC2IS<1:0>	—	—	0000
		15:0	—	—	—	—	—	—	IC2IP<2:0>	IC2IS<1:0>	—	—	—	—	T2IP<2:0>	T2IS<1:0>	—	—	0000
10C0	IPC3	31:16	—	—	—	—	—	—	INT3IP<2:0>	INT3IS<1:0>	—	—	—	—	OC3IP<2:0>	OC3IS<1:0>	—	—	0000
		15:0	—	—	—	—	—	—	IC3IP<2:0>	IC3IS<1:0>	—	—	—	—	T3IP<2:0>	T3IS<1:0>	—	—	0000

Legend: x = unknown value on Reset; — = unimplemented; read as '0'. Reset values are shown in hexadecimal.

Note 1: Except where noted, all registers in this table have corresponding CLR, SET and INV registers at their virtual addresses, plus offsets of 0x4, 0x8 and 0xC, respectively. See [Section 12.1.1 "CLR, SET and INV Registers"](#) for more information.

2: This bit is unimplemented on PIC32MX764F128L device.

3: This register does not have associated CLR, SET, and INV registers.

TABLE 4-7: INTERRUPT REGISTER MAP FOR PIC32MX764F128L, PIC32MX775F256L, PIC32MX775F512L AND PIC32MX795F512L DEVICES⁽¹⁾ (CONTINUED)

Virtual Address (BF88 #)	Register Name	Bit Range	Bits																All Resets		
			31/15	30/14	29/13	28/12	27/11	26/10	25/9	24/8	23/7	22/6	21/5	20/4	19/3	18/2	17/1	16/0			
10D0	IPC4	31:16	—	—	—	—	INT4IP<2:0>	—	INT4IS<1:0>	—	—	—	—	—	—	—	—	—	OC4IP<2:0>	OC4IS<1:0>	0000
10E0	IPC5	31:16	—	—	—	—	IC4IP<2:0>	—	IC4IS<1:0>	—	—	—	—	—	—	—	—	—	T4IP<2:0>	T4IS<1:0>	0000
		15:0	—	—	—	—	SPI1IP<2:0>	—	SPI1IS<1:0>	—	—	—	—	—	—	—	—	—	OC5IP<2:0>	OC5IS<1:0>	0000
		15:0	—	—	—	—	IC5IP<2:0>	—	IC5IS<1:0>	—	—	—	—	—	—	—	—	—	T5IP<2:0>	T5IS<1:0>	0000
		31:16	—	—	—	—	AD1IP<2:0>	—	AD1IS<1:0>	—	—	—	—	—	—	—	—	—	CNIP<2:0>	CNIS<1:0>	0000
10F0	IPC6	15:0	—	—	—	—	I2C1IP<2:0>	—	I2C1IS<1:0>	—	—	—	—	—	—	—	—	—	U1IP<2:0>	U1IS<1:0>	0000
		31:16	—	—	—	—	U3IP<2:0>	—	U3IS<1:0>	—	—	—	—	—	—	—	—	—	SPI3IP<2:0>	SPI3IS<1:0>	0000
		31:16	—	—	—	—	SPI2IP<2:0>	—	SPI2IS<1:0>	—	—	—	—	—	—	—	—	—	I2C3IP<2:0>	I2C3IS<1:0>	0000
1100	IPC7	15:0	—	—	—	—	I2C4IP<2:0>	—	I2C4IS<1:0>	—	—	—	—	—	—	—	—	—	CMP2IP<2:0>	CMP2IS<1:0>	0000
		15:0	—	—	—	—	CMP1IP<2:0>	—	CMP1IS<1:0>	—	—	—	—	—	—	—	—	—	PMPIP<2:0>	PMPIPS<1:0>	0000
		31:16	—	—	—	—	RTCCIP<2:0>	—	RTCCIS<1:0>	—	—	—	—	—	—	—	—	—	FSCMIP<2:0>	FSCMIS<1:0>	0000
1110	IPC8	15:0	—	—	—	—	I2C2IP<2:0>	—	I2C2IS<1:0>	—	—	—	—	—	—	—	—	—	U2IP<2:0>	U2IS<1:0>	0000
		31:16	—	—	—	—	DMA3IP<2:0>	—	DMA3IS<1:0>	—	—	—	—	—	—	—	—	—	SPI4IP<2:0>	SP4IS<1:0>	0000
1120	IPC9	15:0	—	—	—	—	DMA1IP<2:0>	—	DMA1IS<1:0>	—	—	—	—	—	—	—	—	—	I2C5IP<2:0>	I2C5IS<1:0>	0000
		31:16	—	—	—	—	DMA7IP<2:0> ⁽²⁾	—	DMA7IS<1:0> ⁽²⁾	—	—	—	—	—	—	—	—	—	DMA2IP<2:0>	DMA2IS<1:0>	0000
1130	IPC10	15:0	—	—	—	—	DMA5IP<2:0> ⁽²⁾	—	DMA5IS<1:0> ⁽²⁾	—	—	—	—	—	—	—	—	—	DMA0IP<2:0>	DMA0IS<1:0>	0000
		31:16	—	—	—	—	CAN2IP<2:0> ⁽²⁾	—	CAN2IS<1:0> ⁽²⁾	—	—	—	—	—	—	—	—	—	DMA6IP<2:0> ⁽²⁾	DMA6IS<1:0> ⁽²⁾	0000
1140	IPC11	15:0	—	—	—	—	USBIP<2:0>	—	USBIS<1:0>	—	—	—	—	—	—	—	—	—	DMA4IP<2:0> ⁽²⁾	DMA4IS<1:0> ⁽²⁾	0000
		31:16	—	—	—	—	U5IP<2:0>	—	U5IS<1:0>	—	—	—	—	—	—	—	—	—	CAN1IP<2:0>	CAN1IS<1:0>	0000
1150	IPC12	15:0	—	—	—	—	U4IP<2:0>	—	U4IS<1:0>	—	—	—	—	—	—	—	—	—	FCEIP<2:0>	FCEIS<1:0>	0000
		31:16	—	—	—	—	U6IP<2:0>	—	U6IS<1:0>	—	—	—	—	—	—	—	—	—	U6IP<2:0>	U6IS<1:0>	0000
		15:0	—	—	—	—	U4IP<2:0>	—	U4IS<1:0>	—	—	—	—	—	—	—	—	—	ETHIP<2:0>	ETHIS<1:0>	0000

Legend: x = unknown value on Reset; — = unimplemented, read as '0'. Reset values are shown in hexadecimal.

- Note 1:** Except where noted, all registers in this table have corresponding CLR, SET and INV registers at their virtual addresses, plus offsets of 0x4, 0x8 and 0xC, respectively. See [Section 12.1.1 "CLR, SET and INV Registers"](#) for more information.
- 2:** This bit is unimplemented on PIC32MX764F128L device.
- 3:** This register does not have associated CLR, SET, and INV registers.

TABLE 4-9: INPUT CAPTURE 1-INPUT CAPTURE 5 REGISTER MAP

Virtual Address (BF80_#)	Register Name	Bit Range	Bits													All Resets		
			31/15	30/14	29/13	28/12	27/11	26/10	25/9	24/8	23/7	22/6	21/5	20/4	19/3		18/2	17/1
2000	IC1CON ⁽¹⁾	31:16 15:0	— ON	— FRZ	— SIDL	— —	— —	— —	— —	— —	FEDGE —	C32 —	ICTMR —	ICI<1:0> —	ICOV —	ICBNE —	ICM<2:0> —	0000 0000
2010	IC1BUF	31:16 15:0	IC1BUF<31:0>															xxxxx xxxxx
2200	IC2CON ⁽¹⁾	31:16 15:0	— ON	— FRZ	— SIDL	— —	— —	— —	— —	— —	FEDGE —	C32 —	ICTMR —	ICI<1:0> —	ICOV —	ICBNE —	ICM<2:0> —	0000 0000
2210	IC2BUF	31:16 15:0	IC2BUF<31:0>															xxxxx xxxxx
2400	IC3CON ⁽¹⁾	31:16 15:0	— ON	— FRZ	— SIDL	— —	— —	— —	— —	— —	FEDGE —	C32 —	ICTMR —	ICI<1:0> —	ICOV —	ICBNE —	ICM<2:0> —	0000 0000
2410	IC3BUF	31:16 15:0	IC3BUF<31:0>															xxxxx xxxxx
2600	IC4CON ⁽¹⁾	31:16 15:0	— ON	— FRZ	— SIDL	— —	— —	— —	— —	— —	FEDGE —	C32 —	ICTMR —	ICI<1:0> —	ICOV —	ICBNE —	ICM<2:0> —	0000 0000
2610	IC4BUF	31:16 15:0	IC4BUF<31:0>															xxxxx xxxxx
2800	IC5CON ⁽¹⁾	31:16 15:0	— ON	— FRZ	— SIDL	— —	— —	— —	— —	— —	FEDGE —	C32 —	ICTMR —	ICI<1:0> —	ICOV —	ICBNE —	ICM<2:0> —	0000 0000
2810	IC5BUF	31:16 15:0	IC5BUF<31:0>															xxxxx xxxxx

Legend: x = unknown value on Reset; — = unimplemented, read as '0'. Reset values are shown in hexadecimal.

Note 1: This register has corresponding CLR, SET and INV registers at its virtual address, plus an offset of 0x4, 0x8 and 0xC, respectively. See Section 12.1.1 "CLR, SET and INV Registers" for more information.

TABLE 4-10: OUTPUT COMPARE 1-OUTPUT COMPARE 5 REGISTER MAP(1)

Virtual Address (BF8 #)	Register Name	Bit Range	Bits																All Resets
			31/15	30/14	29/13	28/12	27/11	26/10	25/9	24/8	23/7	22/6	21/5	20/4	19/3	18/2	17/1	16/0	
3000	OC1CON	31:16 15:0	— ON	— FRZ	— SIDL	— —	— —	— —	— —	— —	— —	— —	— —	— —	— —	— —	— —	— —	0000 0000
3010	OC1R	31:16 15:0	OC1R<31:0>																0000 0000 xxxx xxxx
3020	OC1RS	31:16 15:0	OC1RS<31:0>																xxxx xxxx
3200	OC2CON	31:16 15:0	— ON	— FRZ	— SIDL	— —	— —	— —	— —	— —	— —	— —	— —	— —	— —	— —	— —	— —	0000 0000
3210	OC2R	31:16 15:0	OC2R<31:0>																xxxx xxxx
3220	OC2RS	31:16 15:0	OC2RS<31:0>																xxxx xxxx
3400	OC3CON	31:16 15:0	— ON	— FRZ	— SIDL	— —	— —	— —	— —	— —	— —	— —	— —	— —	— —	— —	— —	— —	0000 0000
3410	OC3R	31:16 15:0	OC3R<31:0>																xxxx xxxx
3420	OC3RS	31:16 15:0	OC3RS<31:0>																xxxx xxxx
3600	OC4CON	31:16 15:0	— ON	— FRZ	— SIDL	— —	— —	— —	— —	— —	— —	— —	— —	— —	— —	— —	— —	— —	0000 0000
3610	OC4R	31:16 15:0	OC4R<31:0>																xxxx xxxx
3620	OC4RS	31:16 15:0	OC4RS<31:0>																xxxx xxxx
3800	OC5CON	31:16 15:0	— ON	— FRZ	— SIDL	— —	— —	— —	— —	— —	— —	— —	— —	— —	— —	— —	— —	— —	0000 0000
3810	OC5R	31:16 15:0	OC5R<31:0>																xxxx xxxx
3820	OC5RS	31:16 15:0	OC5RS<31:0>																xxxx xxxx

Legend: x = unknown value on Reset; — = unimplemented, read as '0'; Reset values are shown in hexadecimal.

Note 1: All registers in this table have corresponding CLR, SET and INV registers at their virtual addresses, plus offsets of 0x4, 0x8 and 0xC, respectively. See [Section 12.1.1 "CLR, SET and INV Registers"](#) for more information.

TABLE 4-11: I2C1, I2C3, I2C4 AND I2C5 REGISTER MAP(1)

Virtual Address (BF80_#)	Register Name	Bit Range	Bits																All Resets
			31/15	30/14	29/13	28/12	27/11	26/10	25/9	24/8	23/7	22/6	21/5	20/4	19/3	18/2	17/1	16/0	
5000	I2C3CON	31:16	—	—	—	—	—	—	—	—	—	—	—	—	—	—	—	—	0000
		15:0	ON	FRZ	SIDL	SCLREL	STRICT	A10M	DISSLW	SMEN	GCEN	STREN	ACKDT	ACKEN	RCEN	PEN	RSEN	SEN	1000
5010	I2C3STAT	31:16	—	—	—	—	—	—	—	—	—	—	—	—	—	—	—	—	0000
		15:0	ACKSTAT	TRSTAT	—	—	—	BCL	GCSTAT	ADD10	IWCOL	I2COV	D/A	P	S	R/W	RBF	TBF	0000
5020	I2C5DD	31:16	—	—	—	—	—	—	—	—	—	—	—	—	—	—	—	—	0000
		15:0	—	—	—	—	—	—	—	—	—	—	—	—	—	—	—	—	0000
5030	I2C3MSK	31:16	—	—	—	—	—	—	—	—	—	—	—	—	—	—	—	—	0000
		15:0	—	—	—	—	—	—	—	—	—	—	—	—	—	—	—	—	0000
5040	I2C3BRG	31:16	—	—	—	—	—	—	—	—	—	—	—	—	—	—	—	—	0000
		15:0	—	—	—	—	—	—	—	—	—	—	—	—	—	—	—	—	0000
5050	I2C3TRN	31:16	—	—	—	—	—	—	—	—	—	—	—	—	—	—	—	—	0000
		15:0	—	—	—	—	—	—	—	—	—	—	—	—	—	—	—	—	0000
5060	I2C3RCV	31:16	—	—	—	—	—	—	—	—	—	—	—	—	—	—	—	—	0000
		15:0	—	—	—	—	—	—	—	—	—	—	—	—	—	—	—	—	0000
5100	I2C4CON	31:16	—	—	—	—	—	—	—	—	—	—	—	—	—	—	—	—	0000
		15:0	ON	FRZ	SIDL	SCLREL	STRICT	A10M	DISSLW	SMEN	GCEN	STREN	ACKDT	ACKEN	RCEN	PEN	RSEN	SEN	1000
5110	I2C4STAT	31:16	—	—	—	—	—	—	—	—	—	—	—	—	—	—	—	—	0000
		15:0	ACKSTAT	TRSTAT	—	—	—	BCL	GCSTAT	ADD10	IWCOL	I2COV	D/A	P	S	R/W	RBF	TBF	0000
5120	I2C4ADD	31:16	—	—	—	—	—	—	—	—	—	—	—	—	—	—	—	—	0000
		15:0	—	—	—	—	—	—	—	—	—	—	—	—	—	—	—	—	0000
5130	I2C4MSK	31:16	—	—	—	—	—	—	—	—	—	—	—	—	—	—	—	—	0000
		15:0	—	—	—	—	—	—	—	—	—	—	—	—	—	—	—	—	0000
5140	I2C4BRG	31:16	—	—	—	—	—	—	—	—	—	—	—	—	—	—	—	—	0000
		15:0	—	—	—	—	—	—	—	—	—	—	—	—	—	—	—	—	0000
5150	I2C4TRN	31:16	—	—	—	—	—	—	—	—	—	—	—	—	—	—	—	—	0000
		15:0	—	—	—	—	—	—	—	—	—	—	—	—	—	—	—	—	0000
5160	I2C4RCV	31:16	—	—	—	—	—	—	—	—	—	—	—	—	—	—	—	—	0000
		15:0	—	—	—	—	—	—	—	—	—	—	—	—	—	—	—	—	0000
5200	I2C5CON	31:16	—	—	—	—	—	—	—	—	—	—	—	—	—	—	—	—	0000
		15:0	ON	FRZ	SIDL	SCLREL	STRICT	A10M	DISSLW	SMEN	GCEN	STREN	ACKDT	ACKEN	RCEN	PEN	RSEN	SEN	1000
5210	I2C5STAT	31:16	—	—	—	—	—	—	—	—	—	—	—	—	—	—	—	—	0000
		15:0	ACKSTAT	TRSTAT	—	—	—	BCL	GCSTAT	ADD10	IWCOL	I2COV	D/A	P	S	R/W	RBF	TBF	0000

Legend: x = unknown value on Reset; — = unimplemented, read as '0'. Reset values are shown in hexadecimal.

Note 1: All registers in this table except I2CXRCV have corresponding CLR, SET and INV registers at their virtual addresses, plus offsets of 0x4, 0x8 and 0xC, respectively. See [Section 12.1.1 "CLR, SET and INV Registers"](#) for more information.

TABLE 4-12: I2C2 REGISTER MAP FOR PIC32MX534F064L, PIC32MX564F064L, PIC32MX564F128L, PIC32MX564F256L, PIC32MX575F512L, PIC32MX664F064L, PIC32MX664F128L, PIC32MX675F256L, PIC32MX675F512L, PIC32MX695F512L, PIC32MX764F128L, PIC32MX775F256L, PIC32MX775F512L AND PIC32MX795F512L DEVICES⁽¹⁾

Virtual Address (BF80_#)	Register Name	Bit Range	Bits																All Resets
			31/15	30/14	29/13	28/12	27/11	26/10	25/9	24/8	23/7	22/6	21/5	20/4	19/3	18/2	17/1	16/0	
5400	I2C2CON	31:16 15:0	—	FRZ	SIDL	SCLREL	STRICT	A10M	DISSLW	SMEN	GCEN	STREN	ACKDT	ACKEN	RCEN	PEN	RSEN	SEN	0000
5410	I2C2STAT	31:16	—	—	—	—	—	—	—	—	—	—	—	—	—	—	—	—	0000
5420	I2C4DD	31:16 15:0	—	ACKSTAT	TRSTAT	—	BCL	GCSTAT	—	ADD10	IWCOL	I2COV	D/A	P	S	R/W	RBF	TBF	0000
5430	I2C2MSK	31:16 15:0	—	—	—	—	—	—	—	—	—	—	—	—	—	—	—	—	0000
5440	I2C2BRG	31:16 15:0	—	—	—	—	—	—	—	—	—	—	—	—	—	—	—	—	0000
5450	I2C2TRN	31:16 15:0	—	—	—	—	—	—	—	—	—	—	—	—	—	—	—	—	0000
5460	I2C2RCV	31:16 15:0	—	—	—	—	—	—	—	—	—	—	—	—	—	—	—	—	0000

Legend: x = unknown value on Reset; — = unimplemented, read as '0'. Reset values are shown in hexadecimal.

Note 1: All registers in this table except I2CxRCV have corresponding CLR, SET and INV registers at their virtual addresses, plus offsets of 0x4, 0x8 and 0xC, respectively. See [Section 12.1.1 "CLR, SET and INV Registers"](#) for more information.

TABLE 4-14: SPI2, SPI3 AND SPI4 REGISTER MAP(1)

Virtual Address (BF80_#)	Register Name	Bit Range	Bits																All Resets
			31/15	30/14	29/13	28/12	27/11	26/10	25/9	24/8	23/7	22/6	21/5	20/4	19/3	18/2	17/1	16/0	
5800	SPI3CON	31:16 15:0	FRMEN ON	FRMSYNC FRZ	FRMPOL SIDL	MSSSEN DISSDO	FRMSPWP MODE32	FRMCNT<2:0> SMP	MODE16 RXBUFELM<4:0>	CKE	SSEN	CKP	MSTEN	—	STXISEL<1:0> TXBUFELM<4:0>	—	SPIFE SRXISEL<1:0>	ENHBUF	0000 0000
5810	SPI3STAT	31:16 15:0	—	—	—	—	—	—	—	—	—	—	—	—	—	—	—	—	0000
5820	SPI3BUF	31:16 15:0	—	—	—	—	—	—	—	—	—	—	—	—	—	—	—	—	0000 0000
5830	SPI3BRG	31:16 15:0	—	—	—	—	—	—	—	—	—	—	—	—	—	—	—	—	0000
5A00	SPI2CON	31:16 15:0	FRMEN ON	FRMSYNC FRZ	FRMPOL SIDL	MSSSEN DISSDO	FRMSPWP MODE32	FRMCNT<2:0> SMP	MODE16 RXBUFELM<4:0>	CKE	SSEN	CKP	MSTEN	—	STXISEL<1:0> TXBUFELM<4:0>	—	SPIFE SRXISEL<1:0>	ENHBUF	0000 0000
5A10	SPI2STAT	31:16 15:0	—	—	—	—	—	—	—	—	—	—	—	—	—	—	—	—	0000
5A20	SPI2BUF	31:16 15:0	—	—	—	—	—	—	—	—	—	—	—	—	—	—	—	—	0000 0000
5A30	SPI2BRG	31:16 15:0	—	—	—	—	—	—	—	—	—	—	—	—	—	—	—	—	0000
5C00	SPI4CON	31:16 15:0	FRMEN ON	FRMSYNC FRZ	FRMPOL SIDL	MSSSEN DISSDO	FRMSPWP MODE32	FRMCNT<2:0> SMP	MODE16 RXBUFELM<4:0>	CKE	SSEN	CKP	MSTEN	—	STXISEL<1:0> TXBUFELM<4:0>	—	SPIFE SRXISEL<1:0>	ENHBUF	0000 0000
5C10	SPI4STAT	31:16 15:0	—	—	—	—	—	—	—	—	—	—	—	—	—	—	—	—	0000
5C20	SPI4BUF	31:16 15:0	—	—	—	—	—	—	—	—	—	—	—	—	—	—	—	—	0000 0000
5C30	SPI4BRG	31:16 15:0	—	—	—	—	—	—	—	—	—	—	—	—	—	—	—	—	0000

Legend: x = unknown value on Reset; — = unimplemented, read as '0'; Reset values are shown in hexadecimal.

Note 1: All registers in this table except SPIxBUF have corresponding CLR, SET and INV registers at their virtual addresses, plus offsets of 0x4, 0x8 and 0xC, respectively. See Section 12.1.1 "CLR, SET and INV Registers" for more information.

TABLE 4-15: SPI1 REGISTER MAP FOR PIC32MX534F064L, PIC32MX564F064L, PIC32MX564F128L, PIC32MX575F256L, PIC32MX575F512L, PIC32MX664F064L, PIC32MX664F128L, PIC32MX675F256L, PIC32MX675F512L, PIC32MX695F512L, PIC32MX764F128L, PIC32MX775F256L, PIC32MX775F512L AND PIC32MX795F512L DEVICES⁽¹⁾

Virtual Address (BT80 _n)	Register Name	Bit Range	Bits																All Resets
			31/15	30/14	29/13	28/12	27/11	26/10	25/9	24/8	23/7	22/6	21/5	20/4	19/3	18/2	17/1	16/0	
5E00	SPI1CON	31:16 15:0	FRMEN ON	FRMSYNC FRZ	FRMPOL SIDL	MSEN DISSDO	FRMSYWPW MODE32	FRMCNT<2:0> MODE16	SMP RXBUFELM<4:0>	CKE	SSEN	CKP	MSTEN	—	STXISEL<1:0> TXBUFELM<4:0>	—	SPIFE	ENHBUF	0000 0000
5E10	SPI1STAT	31:16 15:0	—	—	—	—	—	—	—	—	—	—	—	—	—	—	—	—	0000
5E20	SPI1BUF	31:16 15:0	—	—	—	—	—	—	—	—	—	—	—	—	—	—	—	—	0000 0000
5E30	SPI1BRG	31:16 15:0	—	—	—	—	—	—	—	—	—	—	—	—	—	—	—	—	0000 0000

Legend: x = unknown value on Reset; — = unimplemented, read as '0'. Reset values are shown in hexadecimal.

Note 1: All registers in this table except SPIxBUF have corresponding CLR, SET and INV registers at their virtual addresses, plus offsets of 0x4, 0x8 and 0xC, respectively. See [Section 12.1.1 "CLR, SET and INV Registers"](#) for more information.

TABLE 4-16: ADC REGISTER MAP

Virtual Address (BF80 #)	Register Name	Bit Range	Bits															All Resets		
			31/15	30/14	29/13	28/12	27/11	26/10	25/9	24/8	23/7	22/6	21/5	20/4	19/3	18/2	17/1		16/0	
9000	AD1CON1 ⁽¹⁾	31:16 15:0	— ON	FRZ	SIDL	—	—	—	—	—	—	—	—	—	—	—	—	—	—	0000 0000
9010	AD1CON2 ⁽¹⁾	31:16 15:0	— VCFG2	— VCFG1	— VCFG0	— OFFCAL	— CSCNA	— —	— —	FORM<2:0>	—	—	—	—	—	—	—	—	—	0000 0000
9020	AD1CON3 ⁽¹⁾	31:16 15:0	— ADRC	— —	— —	— —	— —	— —	— —	SAMC<4:0>	—	—	—	—	—	—	—	—	—	0000 0000
9040	AD1CHS ⁽¹⁾	31:16 15:0	— —	— —	— —	— —	— —	— —	— —	CH0SB<3:0>	—	—	—	—	—	—	—	—	—	0000 0000
9060	AD1PCFG ⁽¹⁾	31:16 15:0	— PCFG15	— PCFG14	— PCFG13	— PCFG12	— PCFG11	— PCFG10	— PCFG9	— PCFG8	— PCFG7	— PCFG6	— PCFG5	— PCFG4	— PCFG3	— PCFG2	— PCFG1	— —	— —	0000 0000
9050	AD1CSSL ⁽¹⁾	31:16 15:0	— CSSL15	— CSSL14	— CSSL13	— CSSL12	— CSSL11	— CSSL10	— CSSL9	— CSSL8	— CSSL7	— CSSL6	— CSSL5	— CSSL4	— CSSL3	— CSSL2	— CSSL1	— —	— —	0000 0000
9070	ADC1BUF0	31:16 15:0	ADC Result Word 0 (ADC1BUF0<31:0>)															0000 0000		
9080	ADC1BUF1	31:16 15:0	ADC Result Word 1 (ADC1BUF1<31:0>)															0000 0000		
9090	ADC1BUF2	31:16 15:0	ADC Result Word 2 (ADC1BUF2<31:0>)															0000 0000		
90A0	ADC1BUF3	31:16 15:0	ADC Result Word 3 (ADC1BUF3<31:0>)															0000 0000		
90B0	ADC1BUF4	31:16 15:0	ADC Result Word 4 (ADC1BUF4<31:0>)															0000 0000		
90C0	ADC1BUF5	31:16 15:0	ADC Result Word 5 (ADC1BUF5<31:0>)															0000 0000		
90D0	ADC1BUF6	31:16 15:0	ADC Result Word 6 (ADC1BUF6<31:0>)															0000 0000		
90E0	ADC1BUF7	31:16 15:0	ADC Result Word 7 (ADC1BUF7<31:0>)															0000 0000		
90F0	ADC1BUF8	31:16 15:0	ADC Result Word 8 (ADC1BUF8<31:0>)															0000 0000		
9100	ADC1BUF9	31:16 15:0	ADC Result Word 9 (ADC1BUF9<31:0>)															0000 0000		
9110	ADC1BUFA	31:16 15:0	ADC Result Word A (ADC1BUFA<31:0>)															0000 0000		
9120	ADC1BUFB	31:16 15:0	ADC Result Word B (ADC1BUFB<31:0>)															0000 0000		

Legend: x = unknown value on Reset; — = unimplemented, read as '0'; Reset values are shown in hexadecimal.
Note 1: This register has corresponding CLR, SET and INV registers at their virtual addresses, plus offsets of 0x4, 0x8 and 0xC, respectively. See [Section 12.1.1 "CLR, SET and INV Registers"](#) for more information.

TABLE 4-16: ADC REGISTER MAP (CONTINUED)

Virtual Address (BF80 #)	Register Name	Bit Range	Bits																All Resets
			31/15	30/14	29/13	28/12	27/11	26/10	25/9	24/8	23/7	22/6	21/5	20/4	19/3	18/2	17/1	16/0	
9130	ADC1BUFC	31:16 15:0	ADC Result Word C (ADC1BUFC<31:0>)																0000 0000
9140	ADC1BUFD	31:16 15:0	ADC Result Word D (ADC1BUFD<31:0>)																0000 0000
9150	ADC1BUFE	31:16 15:0	ADC Result Word E (ADC1BUFE<31:0>)																0000 0000
9160	ADC1BUFF	31:16 15:0	ADC Result Word F (ADC1BUFF<31:0>)																0000 0000

Legend: x = unknown value on Reset; — = unimplemented; read as '0'. Reset values are shown in hexadecimal.

Note 1: This register has corresponding CLR, SET and INV registers at their virtual addresses, plus offsets of 0x4, 0x8 and 0xC, respectively. See [Section 12.1.1 "CLR, SET and INV Registers"](#) for more information.

TABLE 4-17: DMA GLOBAL REGISTER MAP

Virtual Address (BF88_#)	Register Name	Bit Range	Bits													All Resets			
			31/15	30/14	29/13	28/12	27/11	26/10	25/9	24/8	23/7	22/6	21/5	20/4	19/3	18/2	17/1	16/0	
3000	DMACON ⁽¹⁾	31:16 15:0	—	FRZ	—	SUSPEND	DMABUSY	—	—	—	—	—	—	—	—	—	—	—	0000
3010	DMASTAT	31:16 15:0	—	—	—	—	—	—	—	—	—	—	—	—	RDWR	—	DMACH<2:0> ⁽²⁾	—	0000
3020	DMAADDR	31:16 15:0	DMAADDR<31:0>													0000			

Legend: x = unknown value on Reset; — = unimplemented, read as '0'; Reset values are shown in hexadecimal.

Note 1: This register has corresponding CLR, SET and INV registers at its virtual address, plus an offset of 0x4, 0x8 and 0xC, respectively. See Section 12.1.1 "CLR, SET and INV Registers" for more information.

2: DMACH<3> bit is not available on PIC32MX534/664/764 devices.

TABLE 4-18: DMA CRC REGISTER MAP⁽¹⁾

Virtual Address (BF88_#)	Register Name	Bit Range	Bits													All Resets			
			31/15	30/14	29/13	28/12	27/11	26/10	25/9	24/8	23/7	22/6	21/5	20/4	19/3	18/2	17/1	16/0	
3030	DCRCON	31:16 15:0	—	—	BYTO<1:0>	—	WBO	—	—	BITO	—	—	—	—	—	—	—	—	0000
3040	DCRCDATA	31:16 15:0	DCRCDATA<31:0>													0000			
3050	DCRCXOR	31:16 15:0	DCRCXOR<31:0>													0000			

Legend: x = unknown value on Reset; — = unimplemented, read as '0'; Reset values are shown in hexadecimal.

Note 1: All registers in this table have corresponding CLR, SET and INV registers at their virtual addresses, plus offsets of 0x4, 0x8 and 0xC, respectively. See Section 12.1.1 "CLR, SET and INV Registers" for more information.

TABLE 4-19: DMA CHANNELS 0-7 REGISTER MAP(1,2)

Virtual Address (BF88 #)	Register Name	Bit Range	Bits																All Resets
			31/15	30/14	29/13	28/12	27/11	26/10	25/9	24/8	23/7	22/6	21/5	20/4	19/3	18/2	17/1	16/0	
3060	DCHOCON	31:16 15:0	— CHBUSY	— —	— —	— —	— —	— —	— —	— —	— —	— —	— —	— —	— —	— —	— —	— —	0000 0000
3070	DCH0ECON	31:16 15:0	— —	— —	— —	— —	— —	— —	— —	— —	— —	— —	— —	— —	— —	— —	— —	— —	00FF 0000
3080	DCH0INT	31:16 15:0	— —	— —	— —	— —	— —	— —	— —	— —	— —	— —	— —	— —	— —	— —	— —	— —	0000 0000
3090	DCH0SSA	31:16 15:0	— —	— —	— —	— —	— —	— —	— —	— —	— —	— —	— —	— —	— —	— —	— —	— —	0000 0000
30A0	DCH0DSA	31:16 15:0	— —	— —	— —	— —	— —	— —	— —	— —	— —	— —	— —	— —	— —	— —	— —	— —	0000 0000
30B0	DCH0SSIZ	31:16 15:0	— —	— —	— —	— —	— —	— —	— —	— —	— —	— —	— —	— —	— —	— —	— —	— —	0000 0000
30C0	DCH0DSIZ	31:16 15:0	— —	— —	— —	— —	— —	— —	— —	— —	— —	— —	— —	— —	— —	— —	— —	— —	0000 0000
30D0	DCH0SPTR	31:16 15:0	— —	— —	— —	— —	— —	— —	— —	— —	— —	— —	— —	— —	— —	— —	— —	— —	0000 0000
30E0	DCH0DPTR	31:16 15:0	— —	— —	— —	— —	— —	— —	— —	— —	— —	— —	— —	— —	— —	— —	— —	— —	0000 0000
30F0	DCH0CSIZ	31:16 15:0	— —	— —	— —	— —	— —	— —	— —	— —	— —	— —	— —	— —	— —	— —	— —	— —	0000 0000
3100	DCH0CPTR	31:16 15:0	— —	— —	— —	— —	— —	— —	— —	— —	— —	— —	— —	— —	— —	— —	— —	— —	0000 0000
3110	DCH0DAT	31:16 15:0	— —	— —	— —	— —	— —	— —	— —	— —	— —	— —	— —	— —	— —	— —	— —	— —	0000 0000
3120	DCH1CON	31:16 15:0	— CHBUSY	— —	— —	— —	— —	— —	— —	— —	— —	— —	— —	— —	— —	— —	— —	— —	0000 0000
3130	DCH1ECON	31:16 15:0	— —	— —	— —	— —	— —	— —	— —	— —	— —	— —	— —	— —	— —	— —	— —	— —	00FF 0000
3140	DCH1INT	31:16 15:0	— —	— —	— —	— —	— —	— —	— —	— —	— —	— —	— —	— —	— —	— —	— —	— —	0000 0000
3150	DCH1SSA	31:16 15:0	— —	— —	— —	— —	— —	— —	— —	— —	— —	— —	— —	— —	— —	— —	— —	— —	0000 0000
3160	DCH1DSA	31:16 15:0	— —	— —	— —	— —	— —	— —	— —	— —	— —	— —	— —	— —	— —	— —	— —	— —	0000 0000
3170	DCH1SSIZ	31:16 15:0	— —	— —	— —	— —	— —	— —	— —	— —	— —	— —	— —	— —	— —	— —	— —	— —	0000 0000

Legend:

x = unknown value on Reset; — = unimplemented, read as '0'. Reset values are shown in hexadecimal.

Note 1: All registers in this table have corresponding CLR, SET and INV registers at their virtual addresses, plus offsets of 0x4, 0x8 and 0xC, respectively. See Section 12.1.1 "CLR, SET and INV Registers" for more information.

Note 2: DMA channels 4-7 are note available on PIC32MX534/564/664/764 devices.

TABLE 4-19: DMA CHANNELS 0-7 REGISTER MAP^(1,2) (CONTINUED)

Virtual Address (BF8_#)	Register Name	Bit Range	Bits																All Resets	
			31/15	30/14	29/13	28/12	27/11	26/10	25/9	24/8	23/7	22/6	21/5	20/4	19/3	18/2	17/1	16/0		
3180	DCH1DSIZ	31:16 15:0	—	—	—	—	—	—	—	—	—	—	—	—	—	—	—	—	—	0000 0000
3190	DCH1SPTR	31:16 15:0	—	—	—	—	—	—	—	—	—	—	—	—	—	—	—	—	—	0000 0000
31A0	DCH1DPTR	31:16 15:0	—	—	—	—	—	—	—	—	—	—	—	—	—	—	—	—	—	0000 0000
31B0	DCH1CSIZ	31:16 15:0	—	—	—	—	—	—	—	—	—	—	—	—	—	—	—	—	—	0000 0000
31C0	DCH1CPTR	31:16 15:0	—	—	—	—	—	—	—	—	—	—	—	—	—	—	—	—	—	0000 0000
31D0	DCH1DAT	31:16 15:0	—	—	—	—	—	—	—	—	—	—	—	—	—	—	—	—	—	0000 0000
31E0	DCH2CON	15:0	CHBUSY	—	—	—	—	—	—	—	—	—	—	—	—	—	—	—	—	0000
31F0	DCH2ECON	31:16 15:0	—	—	—	—	—	—	—	—	—	—	—	—	—	—	—	—	—	00FF 0000
3200	DCH2INT	31:16 15:0	—	—	—	—	—	—	—	—	—	—	—	—	—	—	—	—	—	0000 0000
3210	DCH2SSA	31:16 15:0	—	—	—	—	—	—	—	—	—	—	—	—	—	—	—	—	—	0000 0000
3220	DCH2DSA	31:16 15:0	—	—	—	—	—	—	—	—	—	—	—	—	—	—	—	—	—	0000 0000
3230	DCH2SSIZ	31:16 15:0	—	—	—	—	—	—	—	—	—	—	—	—	—	—	—	—	—	0000 0000
3240	DCH2DSIZ	31:16 15:0	—	—	—	—	—	—	—	—	—	—	—	—	—	—	—	—	—	0000 0000
3250	DCH2SPTR	31:16 15:0	—	—	—	—	—	—	—	—	—	—	—	—	—	—	—	—	—	0000 0000
3260	DCH2DPTR	31:16 15:0	—	—	—	—	—	—	—	—	—	—	—	—	—	—	—	—	—	0000 0000
3270	DCH2CSIZ	31:16 15:0	—	—	—	—	—	—	—	—	—	—	—	—	—	—	—	—	—	0000 0000
3280	DCH2CPTR	31:16 15:0	—	—	—	—	—	—	—	—	—	—	—	—	—	—	—	—	—	0000 0000

Legend: x = unknown value on Reset; — = unimplemented; read as '0'. Reset values are shown in hexadecimal.

Note 1: All registers in this table have corresponding CLR, SET and INV registers at their virtual addresses, plus offsets of 0x4, 0x8 and 0xC, respectively. See [Section 12.1.1 "CLR, SET and INV Registers"](#) for more information.

2: DMA channels 4-7 are note available on PIC32MX534/564/664/764 devices.

TABLE 4-19: DMA CHANNELS 0-7 REGISTER MAP^(1,2) (CONTINUED)

Virtual Address (BF88_#)	Register Name	Bit Range	Bits																All Resets		
			31/15	30/14	29/13	28/12	27/11	26/10	25/9	24/8	23/7	22/6	21/5	20/4	19/3	18/2	17/1	16/0			
3290	DCH2DAT	31:16 15:0	—	—	—	—	—	—	—	—	—	—	—	—	—	—	—	—	—	—	0000 0000
32A0	DCH3CON	31:16 15:0	—	—	—	—	—	—	—	—	—	—	—	—	—	—	—	—	—	—	0000 0000
32B0	DCH3ECON	31:16 15:0	—	—	—	—	—	—	—	—	—	—	—	—	—	—	—	—	—	—	0000 0000
32C0	DCH3INT	31:16 15:0	—	—	—	—	—	—	—	—	—	—	—	—	—	—	—	—	—	—	0000 0000
32D0	DCH3SSA	31:16 15:0	—	—	—	—	—	—	—	—	—	—	—	—	—	—	—	—	—	—	0000 0000
32E0	DCH3DSA	31:16 15:0	—	—	—	—	—	—	—	—	—	—	—	—	—	—	—	—	—	—	0000 0000
32F0	DCH3SSIZ	31:16 15:0	—	—	—	—	—	—	—	—	—	—	—	—	—	—	—	—	—	—	0000 0000
3300	DCH3DSIZ	31:16 15:0	—	—	—	—	—	—	—	—	—	—	—	—	—	—	—	—	—	—	0000 0000
3310	DCH3SPTR	31:16 15:0	—	—	—	—	—	—	—	—	—	—	—	—	—	—	—	—	—	—	0000 0000
3320	DCH3DPTR	31:16 15:0	—	—	—	—	—	—	—	—	—	—	—	—	—	—	—	—	—	—	0000 0000
3330	DCH3CSIZ	31:16 15:0	—	—	—	—	—	—	—	—	—	—	—	—	—	—	—	—	—	—	0000 0000
3340	DCH3CPTR	31:16 15:0	—	—	—	—	—	—	—	—	—	—	—	—	—	—	—	—	—	—	0000 0000
3350	DCH3DAT	31:16 15:0	—	—	—	—	—	—	—	—	—	—	—	—	—	—	—	—	—	—	0000 0000
3360	DCH4CON	31:16 15:0	—	—	—	—	—	—	—	—	—	—	—	—	—	—	—	—	—	—	0000 0000
3370	DCH4ECON	31:16 15:0	—	—	—	—	—	—	—	—	—	—	—	—	—	—	—	—	—	—	0000 0000
3380	DCH4INT	31:16 15:0	—	—	—	—	—	—	—	—	—	—	—	—	—	—	—	—	—	—	0000 0000
3390	DCH4SSA	31:16 15:0	—	—	—	—	—	—	—	—	—	—	—	—	—	—	—	—	—	—	0000 0000
33A0	DCH4DSA	31:16 15:0	—	—	—	—	—	—	—	—	—	—	—	—	—	—	—	—	—	—	0000 0000

Legend: x = unknown value on Reset; — = unimplemented, read as '0'; Reset values are shown in hexadecimal.

Note 1: All registers in this table have corresponding CLR, SET and INV registers at their virtual addresses, plus offsets of 0x4, 0x8 and 0xC, respectively. See Section 12.1.1 "CLR, SET and INV Registers" for more information.

2: DMA channels 4-7 are note available on PIC32MX534/564/664/764 devices.

TABLE 4-19: DMA CHANNELS 0-7 REGISTER MAP^(1,2) (CONTINUED)

Virtual Address (BF8 _n)	Register Name	Bit Range	Bits																All Resets	
			31/15	30/14	29/13	28/12	27/11	26/10	25/9	24/8	23/7	22/6	21/5	20/4	19/3	18/2	17/1	16/0		
33B0	DCH4SSIZ	31:16	—	—	—	—	—	—	—	—	—	—	—	—	—	—	—	—	—	0000
		15:0	CHSSIZ<15:0>																0000	
33C0	DCH4DSIZ	31:16	—	—	—	—	—	—	—	—	—	—	—	—	—	—	—	—	—	0000
		15:0	CHDSIZ<15:0>																0000	
33D0	DCH4SPTR	31:16	—	—	—	—	—	—	—	—	—	—	—	—	—	—	—	—	—	0000
		15:0	CHSPTR<15:0>																0000	
33E0	DCH4DPTR	31:16	—	—	—	—	—	—	—	—	—	—	—	—	—	—	—	—	—	0000
		15:0	CHDPTR<15:0>																0000	
33F0	DCH4CSIZ	31:16	—	—	—	—	—	—	—	—	—	—	—	—	—	—	—	—	—	0000
		15:0	CHCSIZ<15:0>																0000	
3400	DCH4CPTR	31:16	—	—	—	—	—	—	—	—	—	—	—	—	—	—	—	—	—	0000
		15:0	CHCPTR<15:0>																0000	
3410	DCH4DAT	31:16	—	—	—	—	—	—	—	—	—	—	—	—	—	—	—	—	—	0000
		15:0	CHPDAT<7:0>																0000	
3420	DCH5CON	31:16	—	—	—	—	—	—	—	—	—	—	—	—	—	—	—	—	—	0000
		15:0	CHBUSY	—	—	—	—	—	—	—	—	—	—	—	—	—	—	—	—	0000
3430	DCH5ECON	31:16	—	—	—	—	—	—	—	—	—	—	—	—	—	—	—	—	—	0000
		15:0	CHSRQ<7:0>	—	—	—	—	—	—	—	—	—	—	—	—	—	—	—	—	0000
3440	DCH5INT	31:16	—	—	—	—	—	—	—	—	—	—	—	—	—	—	—	—	—	0000
		15:0	CHSDF	CHSHIF	CHSHIF	CHSHIF	CHSHIF	CHSHIF	CHSHIF	CHSHIF	CHSHIF	CHSHIF	CHSHIF	CHSHIF	CHSHIF	CHSHIF	CHSHIF	CHSHIF	CHSHIF	0000
3450	DCH5SSA	31:16	—	—	—	—	—	—	—	—	—	—	—	—	—	—	—	—	—	0000
		15:0	CHSSA<31:0>																0000	
3460	DCH5DSA	31:16	—	—	—	—	—	—	—	—	—	—	—	—	—	—	—	—	—	0000
		15:0	CHDSA<31:0>																0000	
3470	DCH5SSIZ	31:16	—	—	—	—	—	—	—	—	—	—	—	—	—	—	—	—	—	0000
		15:0	CHSSIZ<15:0>																0000	
3480	DCH5DSIZ	31:16	—	—	—	—	—	—	—	—	—	—	—	—	—	—	—	—	—	0000
		15:0	CHDSIZ<15:0>																0000	
3490	DCH5SPTR	31:16	—	—	—	—	—	—	—	—	—	—	—	—	—	—	—	—	—	0000
		15:0	CHSPTR<15:0>																0000	
34A0	DCH5DPTR	31:16	—	—	—	—	—	—	—	—	—	—	—	—	—	—	—	—	—	0000
		15:0	CHDPTR<15:0>																0000	
34B0	DCH5CSIZ	31:16	—	—	—	—	—	—	—	—	—	—	—	—	—	—	—	—	—	0000
		15:0	CHCSIZ<15:0>																0000	
34C0	DCH5CPTR	31:16	—	—	—	—	—	—	—	—	—	—	—	—	—	—	—	—	—	0000
		15:0	CHCPTR<15:0>																0000	

Legend: x = unknown value on Reset; — = unimplemented, read as '0'. Reset values are shown in hexadecimal.

Note 1: All registers in this table have corresponding CLR, SET and INV registers at their virtual addresses, plus offsets of 0x4, 0x8 and 0xC, respectively. See Section 12.1.1 "CLR, SET and INV Registers" for more information.

2: DMA channels 4-7 are note available on PIC32MX534/564/664/764 devices.

TABLE 4-19: DMA CHANNELS 0-7 REGISTER MAP^(1,2) (CONTINUED)

Virtual Address (BF8 #)	Register Name	Bit Range	Bits																All Resets								
			31/15	30/14	29/13	28/12	27/11	26/10	25/9	24/8	23/7	22/6	21/5	20/4	19/3	18/2	17/1	16/0									
34D0	DCH6DAT	31:16 15:0	—	—	—	—	—	—	—	—	—	—	—	—	—	—	—	—	—	—	0000						
			CHPDAT<7:0>																0000								
34E0	DCH6CON	31:16 15:0	—	—	—	—	—	—	—	—	—	—	—	—	—	—	—	—	—	—	0000						
			CHBUSY			CHCHNS			CHEN			CHAED			CHCHN			CHAEN			CHEDET			0000			
34F0	DCH6ECON	31:16 15:0	—	—	—	—	—	—	—	—	—	—	—	—	—	—	—	—	—	—	00FF						
			CHSIROQ<7:0>				CFORCE				CABORT				PATEN				SIRQEN				AIRQEN				FF00
3500	DCH6INT	31:16 15:0	—	—	—	—	—	—	—	—	—	—	—	—	—	—	—	—	—	—	0000						
			CHSDIE			CHSHIE			CHSDIF			CHSHIF			CHDDIF			CHDHIF			CHCCIE			CHCCIF			0000
3510	DCH6SSA	31:16 15:0	CHSSA<31:0>																0000								
3520	DCH6DSA	31:16 15:0	CHDSA<31:0>																0000								
3530	DCH6SSIZ	31:16 15:0	CHSSIZ<15:0>																0000								
3540	DCH6DSIZ	31:16 15:0	CHDSIZ<15:0>																0000								
3550	DCH6SPTR	31:16 15:0	CHSPTR<15:0>																0000								
3560	DCH6DPTR	31:16 15:0	CHDPTR<15:0>																0000								
3570	DCH6CSIZ	31:16 15:0	CHCSIZ<15:0>																0000								
3580	DCH6CPTR	31:16 15:0	CHCPTR<15:0>																0000								
3590	DCH6DAT	31:16 15:0	—	—	—	—	—	—	—	—	—	—	—	—	—	—	—	—	—	—	0000						
			CHPDAT<7:0>																0000								
35A0	DCH7CON	31:16 15:0	—	—	—	—	—	—	—	—	—	—	—	—	—	—	—	—	—	—	0000						
			CHBUSY			CHCHNS			CHEN			CHAED			CHCHN			CHAEN			CHEDET			0000			
35B0	DCH7ECON	31:16 15:0	—	—	—	—	—	—	—	—	—	—	—	—	—	—	—	—	—	—	00FF						
			CHSIROQ<7:0>				CFORCE				CABORT				PATEN				SIRQEN				AIRQEN				FF00
35C0	DCH7INT	31:16 15:0	—	—	—	—	—	—	—	—	—	—	—	—	—	—	—	—	—	—	0000						
			CHSDIE			CHSHIE			CHSDIF			CHSHIF			CHDDIF			CHDHIF			CHCCIE			CHCCIF			0000
35D0	DCH7SSA	31:16 15:0	CHSSA<31:0>																0000								
35E0	DCH7DSA	31:16 15:0	CHDSA<31:0>																0000								

Legend: x = unknown value on Reset; — = unimplemented, read as '0'. Reset values are shown in hexadecimal.

Note 1: All registers in this table have corresponding CLR, SET and INV registers at their virtual addresses, plus offsets of 0x4, 0x8 and 0xC, respectively. See Section 12.1.1 "CLR, SET and INV Registers" for more information.

2: DMA channels 4-7 are not available on PIC32MX534/564/664/764 devices.

TABLE 4-19: DMA CHANNELS 0-7 REGISTER MAP^(1,2) (CONTINUED)

Virtual Address (BF8_#)	Register Name	Bit Range	Bits																All Resets	
			31/15	30/14	29/13	28/12	27/11	26/10	25/9	24/8	23/7	22/6	21/5	20/4	19/3	18/2	17/1	16/0		
35F0	DCH7SSIZ	31:16 15:0	—	—	—	—	—	—	—	—	—	—	—	—	—	—	—	—	—	0000
			CHSSIZ<15:0>																0000	
3600	DCH7DSIZ	31:16 15:0	—	—	—	—	—	—	—	—	—	—	—	—	—	—	—	—	—	0000
			CHDSIZ<15:0>																0000	
3610	DCH7SPTR	31:16 15:0	—	—	—	—	—	—	—	—	—	—	—	—	—	—	—	—	—	0000
			CHSPTR<15:0>																0000	
3620	DCH7DPTR	31:16 15:0	—	—	—	—	—	—	—	—	—	—	—	—	—	—	—	—	—	0000
			CHDPTR<15:0>																0000	
3630	DCH7CSIZ	31:16 15:0	—	—	—	—	—	—	—	—	—	—	—	—	—	—	—	—	—	0000
			CHCSIZ<15:0>																0000	
3640	DCH7CPTR	31:16 15:0	—	—	—	—	—	—	—	—	—	—	—	—	—	—	—	—	—	0000
			CHCPTR<15:0>																0000	
3650	DCH7DAT	31:16 15:0	—	—	—	—	—	—	—	—	—	—	—	—	—	—	—	—	—	0000
			CHPDAT<7:0>																0000	

Legend: x = unknown value on Reset; — = unimplemented; read as '0'. Reset values are shown in hexadecimal.

Note 1: All registers in this table have corresponding CLR, SET and INV registers at their virtual addresses, plus offsets of 0x4, 0x8 and 0xC, respectively. See Section 12.1.1 "CLR, SET and INV Registers" for more information.

2: DMA channels 4-7 are not available on PIC32MX534/564/664/764 devices.

TABLE 4-20: COMPARATOR REGISTER MAP⁽¹⁾

Virtual Address (BF80_#)	Register Name	Bit Range	Bits																All Resets	
			31/15	30/14	29/13	28/12	27/11	26/10	25/9	24/8	23/7	22/6	21/5	20/4	19/3	18/2	17/1	16/0		
A000	CM1CON	31:16	—	—	—	—	—	—	—	—	—	—	—	—	—	—	—	—	—	0000
		15:0	ON	COE	CPOL	—	—	—	—	—	—	—	—	—	—	—	—	—	—	00C3
A010	CM2CON	31:16	—	—	—	—	—	—	—	—	—	—	—	—	—	—	—	—	—	0000
		15:0	ON	COE	CPOL	—	—	—	—	—	—	—	—	—	—	—	—	—	—	00C3
A060	CMSTAT	31:16	—	—	—	—	—	—	—	—	—	—	—	—	—	—	—	—	—	0000
		15:0	—	FRZ	SIDL	—	—	—	—	—	—	—	—	—	—	—	—	—	—	0000
																		C2OUT	C1OUT	0000

Legend: x = unknown value on Reset; — = unimplemented, read as '0'. Reset values are shown in hexadecimal.

Note 1: All registers in this table have corresponding CLR, SET and INV registers at their virtual addresses, plus offsets of 0x4, 0x8 and 0xC, respectively. See [Section 12.1.1 "CLR, SET and INV Registers"](#), for more information.

TABLE 4-21: COMPARATOR VOLTAGE REFERENCE REGISTER MAP⁽¹⁾

Virtual Address (BF80_#)	Register Name	Bit Range	Bits																All Resets		
			31/15	30/14	29/13	28/12	27/11	26/10	25/9	24/8	23/7	22/6	21/5	20/4	19/3	18/2	17/1	16/0			
9800	CVRCON	31:16	—	—	—	—	—	—	—	—	—	—	—	—	—	—	—	—	—	—	0000
		15:0	ON	—	—	—	—	—	—	—	—	—	—	—	—	—	—	—	—	—	0100
																					0000
																					0100

Legend: x = unknown value on Reset; — = unimplemented, read as '0'. Reset values are shown in hexadecimal.

Note 1: All registers in this table have corresponding CLR, SET and INV registers at their virtual addresses, plus offsets of 0x4, 0x8 and 0xC, respectively. See [Section 12.1.1 "CLR, SET and INV Registers"](#), for more information.

2: These bits are not available on PIC32MX575/675/695/775 devices. On these devices, reset value for CVRCON is 0000.

TABLE 4-24: PORTA REGISTER MAP FOR PIC32MX534F064L, PIC32MX564F064L, PIC32MX564F128L, PIC32MX564F256L, PIC32MX575F512L, PIC32MX664F064L, PIC32MX664F128L, PIC32MX675F256L, PIC32MX675F512L, PIC32MX695F512L, PIC32MX764F128L, PIC32MX775F256L, PIC32MX775F512L AND PIC32MX795F512L DEVICES⁽¹⁾

Virtual Address (BF88_#)	Register Name	Bit Range	Bits															All Resets
			31/15	30/14	29/13	28/12	27/11	26/10	25/9	24/8	23/7	22/6	21/5	20/4	19/3	18/2	17/1	
6000	TRISA	31:16 15:0	— TRISA15 TRISA14	— TRISA14 —	— — —	— — —	— TRISA10 —	— TRISA9 —	— — —	— — —	— TRISA7 —	— TRISA6 TRISA5	— TRISA4 —	— TRISA3 —	— TRISA2 —	— TRISA1 —	— TRISA0 —	0000 C6FF 0000
6010	PORTA	31:16 15:0	— RA15 RA14	— RA14 —	— — —	— — —	— RA10 —	— RA9 —	— — —	— — —	— RA7 —	— RA6 RA5	— RA4 —	— RA3 —	— RA2 —	— RA1 —	— RA0 —	xxxxx 0000
6020	LATA	31:16 15:0	— LATA15 LATA14	— LATA14 —	— — —	— LATA10 —	— LATA9 —	— — —	— — —	— LATA7 —	— LATA6 LATA5	— LATA4 —	— LATA3 —	— LATA2 —	— LATA1 —	— LATA0 —	— — —	xxxxx 0000
6030	ODCA	31:16 15:0	— ODCA15 ODCA14	— ODCA14 —	— — —	— ODCA10 —	— ODCA9 —	— — —	— — —	— ODCA7 —	— ODCA6 ODCA5	— ODCA4 —	— ODCA3 —	— ODCA2 —	— ODCA1 —	— ODCA0 —	— — —	0000 0000

Legend: x = unknown value on Reset; — = unimplemented, read as '0'. Reset values are shown in hexadecimal.

Note 1: All registers in this table have corresponding CLR, SET and INV registers at their virtual addresses, plus offsets of 0x4, 0x8 and 0xC, respectively. See [Section 12.1.1 "CLR, SET and INV Registers"](#) for more information.

TABLE 4-25: PORTB REGISTER MAP⁽¹⁾

Virtual Address (BF88_#)	Register Name	Bit Range	Bits															All Resets
			31/15	30/14	29/13	28/12	27/11	26/10	25/9	24/8	23/7	22/6	21/5	20/4	19/3	18/2	17/1	
6040	TRISB	31:16 15:0	— TRISB15 TRISB14	— TRISB14 —	— TRISB13 —	— TRISB12 —	— TRISB11 —	— TRISB10 —	— TRISB9 —	— TRISB8 —	— TRISB7 —	— TRISB6 TRISB5	— TRISB4 —	— TRISB3 —	— TRISB2 —	— TRISB1 —	— TRISB0 —	0000 FFFF 0000
6050	PORTB	31:16 15:0	— RB15 RB14	— RB14 —	— RB13 —	— RB12 —	— RB11 —	— RB10 —	— RB9 —	— RB8 —	— RB7 —	— RB6 RB5	— RB4 —	— RB3 —	— RB2 —	— RB1 —	— RB0 —	xxxxx 0000
6060	LATB	31:16 15:0	— LATB15 LATB14	— LATB14 —	— LATB13 —	— LATB12 —	— LATB11 —	— LATB10 —	— LATB9 —	— LATB8 —	— LATB7 —	— LATB6 LATB5	— LATB4 —	— LATB3 —	— LATB2 —	— LATB1 —	— LATB0 —	xxxxx 0000
6070	ODCB	31:16 15:0	— ODCB15 ODCB14	— ODCB14 —	— ODCB13 —	— ODCB12 —	— ODCB11 —	— ODCB10 —	— ODCB9 —	— ODCB8 —	— ODCB7 —	— ODCB6 ODCB5	— ODCB4 —	— ODCB3 —	— ODCB2 —	— ODCB1 —	— ODCB0 —	0000 0000

Legend: x = unknown value on Reset; — = unimplemented, read as '0'. Reset values are shown in hexadecimal.

Note 1: All registers in this table have corresponding CLR, SET and INV registers at their virtual addresses, plus offsets of 0x4, 0x8 and 0xC, respectively. See [Section 12.1.1 "CLR, SET and INV Registers"](#) for more information.

TABLE 4-26: PORTC REGISTER MAP FOR PIC32MX534F064H, PIC32MX564F064H, PIC32MX564F128H, PIC32MX564F256H, PIC32MX575F128H, PIC32MX575F128H, PIC32MX664F064H, PIC32MX664F128H, PIC32MX664F256H, PIC32MX675F128H, PIC32MX675F256H, PIC32MX675F512H, PIC32MX675F512H, PIC32MX695F512H, PIC32MX764F128H, PIC32MX775F256H, PIC32MX775F512H AND PIC32MX795F512H DEVICES⁽¹⁾

Virtual Address (BF88_#)	Register Name	Bit Range	Bits																All Resets
			31/15	30/14	29/13	28/12	27/11	26/10	25/9	24/8	23/7	22/6	21/5	20/4	19/3	18/2	17/1	16/0	
6080	TRISC	31:16	—	—	—	—	—	—	—	—	—	—	—	—	—	—	—	—	0000
		15:0	TRISC15	TRISC14	TRISC13	TRISC12	—	—	—	—	—	—	—	—	—	—	—	—	F000
6090	PORTC	31:16	—	—	—	—	—	—	—	—	—	—	—	—	—	—	—	—	0000
		15:0	RC15	RC14	RC13	RC12	—	—	—	—	—	—	—	—	—	—	—	—	xxxx
60A0	LATC	31:16	—	—	—	—	—	—	—	—	—	—	—	—	—	—	—	—	0000
		15:0	LATC15	LATC14	LATC13	LATC12	—	—	—	—	—	—	—	—	—	—	—	—	xxxx
60B0	ODCC	31:16	—	—	—	—	—	—	—	—	—	—	—	—	—	—	—	—	0000
		15:0	ODCC15	ODCC14	ODCC13	ODCC12	—	—	—	—	—	—	—	—	—	—	—	—	0000

Legend: x = unknown value on Reset; — = unimplemented; read as '0'. Reset values are shown in hexadecimal.

Note 1: All registers in this table have corresponding CLR, SET and INV registers at their virtual addresses, plus offsets of 0x4, 0x8 and 0xC, respectively. See [Section 12.1.1 "CLR, SET and INV Registers"](#) for more information.

TABLE 4-27: PORTC REGISTER MAP FOR PIC32MX534F064L, PIC32MX564F064L, PIC32MX564F128L, PIC32MX564F256L, PIC32MX575F128L, PIC32MX664F064L, PIC32MX664F128L, PIC32MX664F256L, PIC32MX675F128L, PIC32MX675F256L, PIC32MX675F512L, PIC32MX675F512L, PIC32MX695F512L, PIC32MX764F128L, PIC32MX775F256L, PIC32MX775F512L AND PIC32MX795F512L DEVICES⁽¹⁾

Virtual Address (BF88_#)	Register Name	Bit Range	Bits																All Resets
			31/15	30/14	29/13	28/12	27/11	26/10	25/9	24/8	23/7	22/6	21/5	20/4	19/3	18/2	17/1	16/0	
6080	TRISC	31:16	—	—	—	—	—	—	—	—	—	—	—	—	—	—	—	—	0000
		15:0	TRISC15	TRISC14	TRISC13	TRISC12	—	—	—	—	—	—	—	—	—	—	—	—	F00F
6090	PORTC	31:16	—	—	—	—	—	—	—	—	—	—	—	—	—	—	—	—	0000
		15:0	RC15	RC14	RC13	RC12	—	—	—	—	—	—	—	—	—	—	—	—	xxxx
60A0	LATC	31:16	—	—	—	—	—	—	—	—	—	—	—	—	—	—	—	—	0000
		15:0	LATC15	LATC14	LATC13	LATC12	—	—	—	—	—	—	—	—	—	—	—	—	xxxx
60B0	ODCC	31:16	—	—	—	—	—	—	—	—	—	—	—	—	—	—	—	—	0000
		15:0	ODCC15	ODCC14	ODCC13	ODCC12	—	—	—	—	—	—	—	—	—	—	—	—	0000

Legend: x = unknown value on Reset; — = unimplemented; read as '0'. Reset values are shown in hexadecimal.

Note 2: All registers in this table have corresponding CLR, SET and INV registers at their virtual addresses, plus offsets of 0x4, 0x8 and 0xC, respectively. See [Section 12.1.1 "CLR, SET and INV Registers"](#) for more information.

TABLE 4-28: PORTD REGISTER MAP FOR PIC32MX534F064H, PIC32MX564F064H, PIC32MX564F128H, PIC32MX564F128H, PIC32MX575F256H, PIC32MX575F512H, PIC32MX664F064H, PIC32MX664F128H, PIC32MX675F256H, PIC32MX675F512H, PIC32MX695F512H, PIC32MX775F256H, PIC32MX775F512H AND PIC32MX795F512H DEVICES⁽¹⁾

Virtual Address (BF8_#)	Register Name	Bit Range	Bits													All Resets			
			31/15	30/14	29/13	28/12	27/11	26/10	25/9	24/8	23/7	22/6	21/5	20/4	19/3		18/2	17/1	16/0
60C0	TRISD	31:16	—	—	—	—	—	—	—	—	—	—	—	—	—	—	—	—	0000
		15:0	—	—	—	—	—	—	—	—	—	—	—	—	—	—	—	—	0FFF
60D0	PORTD	31:16	—	—	—	—	—	—	—	—	—	—	—	—	—	—	—	—	0000
		15:0	—	—	—	—	—	—	—	—	—	—	—	—	—	—	—	—	xxxx
60E0	LATD	31:16	—	—	—	—	—	—	—	—	—	—	—	—	—	—	—	—	0000
		15:0	—	—	—	—	—	—	—	—	—	—	—	—	—	—	—	—	xxxx
60F0	ODCD	31:16	—	—	—	—	—	—	—	—	—	—	—	—	—	—	—	—	0000
		15:0	—	—	—	—	—	—	—	—	—	—	—	—	—	—	—	—	0000

Legend: x = unknown value on Reset; — = unimplemented, read as '0'. Reset values are shown in hexadecimal.

Note 1: All registers in this table have corresponding CLR, SET and INV registers at their virtual addresses, plus offsets of 0x4, 0x8 and 0xC, respectively. See [Section 12.1.1 "CLR, SET and INV Registers"](#) for more information.

TABLE 4-29: PORTD REGISTER MAP FOR PIC32MX534F064L, PIC32MX564F064L, PIC32MX564F128L, PIC32MX564F128L, PIC32MX575F256L, PIC32MX575F512L, PIC32MX664F064L, PIC32MX664F128L, PIC32MX675F256L, PIC32MX675F512L, PIC32MX695F512L, PIC32MX775F256L, PIC32MX775F512L AND PIC32MX795F512L DEVICES⁽¹⁾

Virtual Address (BF8_#)	Register Name	Bit Range	Bits													All Resets			
			31/15	30/14	29/13	28/12	27/11	26/10	25/9	24/8	23/7	22/6	21/5	20/4	19/3		18/2	17/1	16/0
60C0	TRISD	31:16	—	—	—	—	—	—	—	—	—	—	—	—	—	—	—	—	0000
		15:0	TRISD15	TRISD14	TRISD13	TRISD12	TRISD11	TRISD10	TRISD9	TRISD8	TRISD7	TRISD6	TRISD5	TRISD4	TRISD3	TRISD2	TRISD1	TRISD0	FFFF
60D0	PORTD	31:16	—	—	—	—	—	—	—	—	—	—	—	—	—	—	—	—	0000
		15:0	RD15	RD14	RD13	RD12	RD11	RD10	RD9	RD8	RD7	RD6	RD5	RD4	RD3	RD2	RD1	RD0	xxxx
60E0	LATD	31:16	—	—	—	—	—	—	—	—	—	—	—	—	—	—	—	—	0000
		15:0	LAT15	LAT14	LAT13	LAT12	LAT11	LAT10	LAT9	LAT8	LAT7	LAT6	LAT5	LAT4	LAT3	LAT2	LAT1	LAT0	xxxx
60F0	ODCD	31:16	—	—	—	—	—	—	—	—	—	—	—	—	—	—	—	—	0000
		15:0	ODCD15	ODCD14	ODCD13	ODCD12	ODCD11	ODCD10	ODCD9	ODCD8	ODCD7	ODCD6	ODCD5	ODCD4	ODCD3	ODCD2	ODCD1	ODCD0	0000

Legend: x = unknown value on Reset; — = unimplemented, read as '0'. Reset values are shown in hexadecimal.

Note 1: All registers in this table have corresponding CLR, SET and INV registers at their virtual addresses, plus offsets of 0x4, 0x8 and 0xC, respectively. See [Section 12.1.1 "CLR, SET and INV Registers"](#) for more information.

TABLE 4-30: PORTE REGISTER MAP FOR PIC32MX534F064H, PIC32MX564F064H, PIC32MX564F128H, PIC32MX564F256H, PIC32MX575F128H, PIC32MX575F128H, PIC32MX664F064H, PIC32MX664F128H, PIC32MX675F256H, PIC32MX675F512H, PIC32MX695F512H, PIC32MX775F256H, PIC32MX775F512H AND PIC32MX795F512H DEVICES⁽¹⁾

Virtual Address (BF8_#)	Register Name	Bit Range	Bits													All Resets				
			31/15	30/14	29/13	28/12	27/11	26/10	25/9	24/8	23/7	22/6	21/5	20/4	19/3		18/2	17/1	16/0	
6100	TRISE	31:16	—	—	—	—	—	—	—	—	—	—	—	—	—	—	—	—	—	0000
		15:0	—	—	—	—	—	—	—	—	—	—	—	—	—	—	—	—	—	00FF
6110	PORTE	31:16	—	—	—	—	—	—	—	—	—	—	—	—	—	—	—	—	—	0000
		15:0	—	—	—	—	—	—	—	—	—	—	—	—	—	—	—	—	—	xxxx
6120	LATE	31:16	—	—	—	—	—	—	—	—	—	—	—	—	—	—	—	—	—	0000
		15:0	—	—	—	—	—	—	—	—	—	—	—	—	—	—	—	—	—	xxxx
6130	ODCE	31:16	—	—	—	—	—	—	—	—	—	—	—	—	—	—	—	—	—	0000
		15:0	—	—	—	—	—	—	—	—	—	—	—	—	—	—	—	—	—	0000

Legend: x = unknown value on Reset; — = unimplemented, read as '0'. Reset values are shown in hexadecimal.

Note 1: All registers in this table have corresponding CLR, SET and INV registers at their virtual addresses, plus offsets of 0x4, 0x8 and 0xC, respectively. See [Section 12.1.1 "CLR, SET and INV Registers"](#) for more information.

TABLE 4-31: PORTE REGISTER MAP FOR PIC32MX534F064L, PIC32MX564F064L, PIC32MX564F128L, PIC32MX564F256L, PIC32MX575F128L, PIC32MX664F064L, PIC32MX664F128L, PIC32MX675F256L, PIC32MX675F512L, PIC32MX695F512L, PIC32MX775F256L, PIC32MX775F512L AND PIC32MX795F512L DEVICES⁽¹⁾

Virtual Address (BF8_#)	Register Name	Bit Range	Bits													All Resets				
			31/15	30/14	29/13	28/12	27/11	26/10	25/9	24/8	23/7	22/6	21/5	20/4	19/3		18/2	17/1	16/0	
6100	TRISE	31:16	—	—	—	—	—	—	—	—	—	—	—	—	—	—	—	—	—	0000
		15:0	—	—	—	—	—	—	—	—	—	—	—	—	—	—	—	—	—	03FF
6110	PORTE	31:16	—	—	—	—	—	—	—	—	—	—	—	—	—	—	—	—	—	0000
		15:0	—	—	—	—	—	—	—	—	—	—	—	—	—	—	—	—	—	xxxx
6120	LATE	31:16	—	—	—	—	—	—	—	—	—	—	—	—	—	—	—	—	—	0000
		15:0	—	—	—	—	—	—	—	—	—	—	—	—	—	—	—	—	—	xxxx
6130	ODCE	31:16	—	—	—	—	—	—	—	—	—	—	—	—	—	—	—	—	—	0000
		15:0	—	—	—	—	—	—	—	—	—	—	—	—	—	—	—	—	—	0000

Legend: x = unknown value on Reset; — = unimplemented, read as '0'. Reset values are shown in hexadecimal.

Note 1: All registers in this table have corresponding CLR, SET and INV registers at their virtual addresses, plus offsets of 0x4, 0x8 and 0xC, respectively. See [Section 12.1.1 "CLR, SET and INV Registers"](#) for more information.

TABLE 4-32: PORTF REGISTER MAP FOR PIC32MX534F064H, PIC32MX564F064H, PIC32MX564F128H, PIC32MX575F256H, PIC32MX575F512H, PIC32MX664F064H, PIC32MX664F128H, PIC32MX675F256H, PIC32MX675F512H, PIC32MX695F512H, PIC32MX775F256H, PIC32MX775F512H AND PIC32MX795F512H DEVICES⁽¹⁾

Virtual Address (BF8_#)	Register Name	Bit Range	Bits																All Resets	
			31/15	30/14	29/13	28/12	27/11	26/10	25/9	24/8	23/7	22/6	21/5	20/4	19/3	18/2	17/1	16/0		
6140	TRISF	31:16	—	—	—	—	—	—	—	—	—	—	—	—	—	—	—	—	—	0000
		15:0	—	—	—	—	—	—	—	—	—	—	—	—	—	—	—	—	—	003B
6150	PORTF	31:16	—	—	—	—	—	—	—	—	—	—	—	—	—	—	—	—	—	0000
		15:0	—	—	—	—	—	—	—	—	—	—	—	—	—	—	—	—	—	xxxx
6160	LATF	31:16	—	—	—	—	—	—	—	—	—	—	—	—	—	—	—	—	—	0000
		15:0	—	—	—	—	—	—	—	—	—	—	—	—	—	—	—	—	—	xxxx
6170	ODCF	31:16	—	—	—	—	—	—	—	—	—	—	—	—	—	—	—	—	—	0000
		15:0	—	—	—	—	—	—	—	—	—	—	—	—	—	—	—	—	—	0000

Legend: x = unknown value on Reset; — = unimplemented, read as '0'. Reset values are shown in hexadecimal.

Note 1: All registers in this table have corresponding CLR, SET and INV registers at their virtual addresses, plus offsets of 0x4, 0x8 and 0xC, respectively. See Section 12.1.1 “CLR, SET and INV Registers” for more information.

TABLE 4-33: PORTF REGISTER MAP PIC32MX534F064L, PIC32MX564F064L, PIC32MX564F128L, PIC32MX575F256L, PIC32MX575F512L, PIC32MX664F064L, PIC32MX664F128L, PIC32MX675F256L, PIC32MX675F512L, PIC32MX695F512L, PIC32MX775F256L, PIC32MX775F512L AND PIC32MX795F512L DEVICES⁽¹⁾

Virtual Address (BF8_#)	Register Name	Bit Range	Bits																All Resets	
			31/15	30/14	29/13	28/12	27/11	26/10	25/9	24/8	23/7	22/6	21/5	20/4	19/3	18/2	17/1	16/0		
6140	TRISF	31:16	—	—	—	—	—	—	—	—	—	—	—	—	—	—	—	—	—	0000
		15:0	—	—	—	—	—	—	—	—	—	—	—	—	—	—	—	—	—	313F
6150	PORTF	31:16	—	—	—	—	—	—	—	—	—	—	—	—	—	—	—	—	—	0000
		15:0	—	—	—	—	—	—	—	—	—	—	—	—	—	—	—	—	—	xxxx
6160	LATF	31:16	—	—	—	—	—	—	—	—	—	—	—	—	—	—	—	—	—	0000
		15:0	—	—	—	—	—	—	—	—	—	—	—	—	—	—	—	—	—	xxxx
6170	ODCF	31:16	—	—	—	—	—	—	—	—	—	—	—	—	—	—	—	—	—	0000
		15:0	—	—	—	—	—	—	—	—	—	—	—	—	—	—	—	—	—	0000

Legend: x = unknown value on Reset; — = unimplemented, read as '0'. Reset values are shown in hexadecimal.

Note 1: All registers in this table have corresponding CLR, SET and INV registers at their virtual addresses, plus offsets of 0x4, 0x8 and 0xC, respectively. See Section 12.1.1 “CLR, SET and INV Registers” for more information.

TABLE 4-36: CHANGE NOTICE AND PULL-UP REGISTER MAP FOR PIC32MX534F064L, PIC32MX564F064L, PIC32MX564F128L, PIC32MX575F256L, PIC32MX575F512L, PIC32MX664F064L, PIC32MX664F128L, PIC32MX664F256L, PIC32MX675F256L, PIC32MX675F512L, PIC32MX695F512L, PIC32MX764F128L, PIC32MX775F256L, PIC32MX775F512 AND PIC32MX795F512L DEVICES⁽¹⁾

Virtual Address (BF88 #)	Register Name	Bit Range	Bits																All Resets
			31/15	30/14	29/13	28/12	27/11	26/10	25/9	24/8	23/7	22/6	21/5	20/4	19/3	18/2	17/1	16/0	
61C0	CNCON	31:16	—	—	—	—	—	—	—	—	—	—	—	—	—	—	—	—	0000
		15:0	ON	FRZ	SIDL	—	—	—	—	—	—	—	—	—	—	—	—	—	0000
61D0	CNEN	31:16	—	—	—	—	—	—	—	—	—	—	—	—	—	—	—	—	0000
		15:0	CNEN15	CNEN14	CNEN13	CNEN12	CNEN11	CNEN10	CNEN9	CNEN8	CNEN7	CNEN6	CNEN5	CNEN4	CNEN3	CNEN2	CNEN1	CNEN0	0000
61E0	CNPUE	31:16	—	—	—	—	—	—	—	—	—	—	—	—	—	—	—	—	0000
		15:0	CNPUE15	CNPUE14	CNPUE13	CNPUE12	CNPUE11	CNPUE10	CNPUE9	CNPUE8	CNPUE7	CNPUE6	CNPUE5	CNPUE4	CNPUE3	CNPUE2	CNPUE1	CNPUE0	0000

Legend: x = unknown value on Reset; — = unimplemented, read as '0'; Reset values are shown in hexadecimal.

Note 1: All registers in this table have corresponding CLR, SET and INV registers at their virtual addresses, plus offsets of 0x4, 0x8 and 0xC, respectively. See [Section 12.1.1 "CLR, SET and INV Registers"](#) for more information.

TABLE 4-37: CHANGE NOTICE AND PULL-UP REGISTER MAP FOR PIC32MX575F256H, PIC32MX575F512H, PIC32MX675F256H, PIC32MX675F512H AND PIC32MX795F512H DEVICES⁽¹⁾

Virtual Address (BF88 #)	Register Name	Bit Range	Bits																All Resets
			31/15	30/14	29/13	28/12	27/11	26/10	25/9	24/8	23/7	22/6	21/5	20/4	19/3	18/2	17/1	16/0	
61C0	CNCON	31:16	—	—	—	—	—	—	—	—	—	—	—	—	—	—	—	—	0000
		15:0	ON	FRZ	SIDL	—	—	—	—	—	—	—	—	—	—	—	—	—	0000
61D0	CNEN	31:16	—	—	—	—	—	—	—	—	—	—	—	—	—	—	—	—	0000
		15:0	CNEN15	CNEN14	CNEN13	CNEN12	CNEN11	CNEN10	CNEN9	CNEN8	CNEN7	CNEN6	CNEN5	CNEN4	CNEN3	CNEN2	CNEN1	CNEN0	0000
61E0	CNPUE	31:16	—	—	—	—	—	—	—	—	—	—	—	—	—	—	—	—	0000
		15:0	CNPUE15	CNPUE14	CNPUE13	CNPUE12	CNPUE11	CNPUE10	CNPUE9	CNPUE8	CNPUE7	CNPUE6	CNPUE5	CNPUE4	CNPUE3	CNPUE2	CNPUE1	CNPUE0	0000

Legend: x = unknown value on Reset; — = unimplemented, read as '0'; Reset values are shown in hexadecimal.

Note 1: All registers in this table have corresponding CLR, SET and INV registers at their virtual addresses, plus offsets of 0x4, 0x8 and 0xC, respectively. See [Section 12.1.1 "CLR, SET and INV Registers"](#) for more information.

TABLE 4-38: PARALLEL MASTER PORT REGISTER MAP⁽¹⁾

Virtual Address (BF80_#)	Register Name	Bit Range	Bits													All Resets			
			31/15	30/14	29/13	28/12	27/11	26/10	25/9	24/8	23/7	22/6	21/5	20/4	19/3	18/2	17/1	16/0	
7000	PMCON	31:16	—	—	—	—	—	—	—	—	—	—	—	—	—	—	—	—	0000
		15:0	ON	FRZ	SIDL	ADRMUX<1:0>	PMPCTL	PTWREN	PTRDEN	CSF<1:0>	ALP	CS2P	CS1P	RDSP	WRSP	—	—	—	0000
7010	PMMODE	31:16	—	—	—	—	—	—	—	—	—	—	—	—	—	—	—	—	0000
		15:0	BUSY	IRQM<1:0>	INCM<1:0>	MODE16	MODE<1:0>	WAITB<1:0>	WAITM<3:0>	—	—	—	—	—	—	—	—	—	0000
7020	PMADDR	31:16	—	—	—	—	—	—	—	—	—	—	—	—	—	—	—	—	0000
		15:0	CS2EN/A15	CS1EN/A14	ADDR<13:0>	—	—	—	—	—	—	—	—	—	—	—	—	—	0000
7030	PMIDOUT	31:16	—	—	—	—	—	—	—	—	—	—	—	—	—	—	—	—	0000
		15:0	DATAOUT<31:0>	—	—	—	—	—	—	—	—	—	—	—	—	—	—	—	0000
7040	PMIDIN	31:16	—	—	—	—	—	—	—	—	—	—	—	—	—	—	—	—	0000
		15:0	DATAIN<31:0>	—	—	—	—	—	—	—	—	—	—	—	—	—	—	—	0000
7050	PMAEN	31:16	—	—	—	—	—	—	—	—	—	—	—	—	—	—	—	—	0000
		15:0	PTEN<15:0>	—	—	—	—	—	—	—	—	—	—	—	—	—	—	—	0000
7060	PMSTAT	31:16	—	—	—	—	—	—	—	—	—	—	—	—	—	—	—	—	0000
		15:0	IBF	IBOV	IB3F	IB2F	IB1F	IB0F	OBE	OBUF	OB3E	OB2E	OB1E	OB0E	—	—	—	—	008F

Legend: x = unknown value on Reset; — = unimplemented, read as '0'. Reset values are shown in hexadecimal.

Note 1: All registers in this table have corresponding CLR, SET and INV registers at their virtual addresses, plus offsets of 0x4, 0x8 and 0xC, respectively. See Section 12.1.1 “CLR, SET and INV Registers” for more information.

TABLE 4-39: PROGRAMMING AND DIAGNOSTICS REGISTER MAP

Virtual Address (BF80_#)	Register Name	Bit Range	Bits													All Resets			
			31/15	30/14	29/13	28/12	27/11	26/10	25/9	24/8	23/7	22/6	21/5	20/4	19/3	18/2	17/1	16/0	
F200	DDPCON	31:16	—	—	—	—	—	—	—	—	—	—	—	—	—	—	—	—	0000
		15:0	—	—	—	—	—	—	—	—	—	—	—	—	JTAGEN	TROEN	TDOEN	—	0008

Legend: x = unknown value on Reset; — = unimplemented, read as '0'. Reset values are shown in hexadecimal.

TABLE 4-40: PREFETCH REGISTER MAP

Virtual Address (BF8 #)	Register Name	Bit Range	Bits																All Resets
			31/15	30/14	29/13	28/12	27/11	26/10	25/9	24/8	23/7	22/6	21/5	20/4	19/3	18/2	17/1	16/0	
4000	CHECON ^(1,2)	31:16	—	—	—	—	—	—	—	—	—	—	—	—	—	—	—	CHECOH	0000
		15:0	—	—	—	—	—	—	—	—	—	—	—	—	—	—	—	PFMWS<2:0>	0007
4010	CHEACC ⁽¹⁾	31:16	—	—	—	—	—	—	—	—	—	—	—	—	—	—	—	—	0000
		15:0	—	—	—	—	—	—	—	—	—	—	—	—	—	—	—	CHEIDX<3:0>	0000
4020	CHETAG ⁽¹⁾	31:16	—	—	—	—	—	—	—	—	—	—	—	—	—	—	—	—	00:xx
		15:0	—	—	—	—	—	—	—	—	—	—	—	—	—	—	—	—	xx:xx
4030	CHEMSK ⁽¹⁾	31:16	—	—	—	—	—	—	—	—	—	—	—	—	—	—	—	—	0000
		15:0	—	—	—	—	—	—	—	—	—	—	—	—	—	—	—	—	0000
4040	CHEW0	31:16	—	—	—	—	—	—	—	—	—	—	—	—	—	—	—	—	xxxx
		15:0	—	—	—	—	—	—	—	—	—	—	—	—	—	—	—	—	xxxx
4050	CHEW1	31:16	—	—	—	—	—	—	—	—	—	—	—	—	—	—	—	—	xxxx
		15:0	—	—	—	—	—	—	—	—	—	—	—	—	—	—	—	—	xxxx
4060	CHEW2	31:16	—	—	—	—	—	—	—	—	—	—	—	—	—	—	—	—	xxxx
		15:0	—	—	—	—	—	—	—	—	—	—	—	—	—	—	—	—	xxxx
4070	CHEW3	31:16	—	—	—	—	—	—	—	—	—	—	—	—	—	—	—	—	xxxx
		15:0	—	—	—	—	—	—	—	—	—	—	—	—	—	—	—	—	xxxx
4080	CHELRU	31:16	—	—	—	—	—	—	—	—	—	—	—	—	—	—	—	—	0000
		15:0	—	—	—	—	—	—	—	—	—	—	—	—	—	—	—	—	0000
4090	CHEHIT	31:16	—	—	—	—	—	—	—	—	—	—	—	—	—	—	—	—	xxxx
		15:0	—	—	—	—	—	—	—	—	—	—	—	—	—	—	—	—	xxxx
40A0	CHEMIS	31:16	—	—	—	—	—	—	—	—	—	—	—	—	—	—	—	—	xxxx
		15:0	—	—	—	—	—	—	—	—	—	—	—	—	—	—	—	—	xxxx
40C0	CHEPFABT	31:16	—	—	—	—	—	—	—	—	—	—	—	—	—	—	—	—	xxxx
		15:0	—	—	—	—	—	—	—	—	—	—	—	—	—	—	—	—	xxxx

Legend: x = unknown value on Reset; — = unimplemented, read as '0'. Reset values are shown in hexadecimal.

Note 1: This register has corresponding CLR, SET and INV registers at its virtual address, plus an offset of 0x4, 0x8 and 0xC, respectively. See [Section 12.1.1 "CLR, SET and INV Registers"](#) for more information.

Note 2: Reset value is dependent on DEVCFGx configuration.

TABLE 4-41: RTCC REGISTER MAP⁽¹⁾

Virtual Address (BF80_#)	Register Name	Bit Range	Bits																All Resets
			31/15	30/14	29/13	28/12	27/11	26/10	25/9	24/8	23/7	22/6	21/5	20/4	19/3	18/2	17/1	16/0	
0200	RTCCON	31:16	—	—	—	—	—	—	—	—	—	—	—	—	—	—	—	—	0000
		15:0	ON	FRZ	SIDL	—	—	—	—	—	—	—	—	—	—	—	—	—	0000
0210	RTCALRM	31:16	—	—	—	—	—	—	—	—	—	—	—	—	—	—	—	—	0000
		15:0	ALRMEN	CHIME	PIV	ALRMSYNC	—	—	—	—	—	—	—	—	—	—	—	—	0000
0220	RTCTIME	31:16	HR10<3:0>	—	—	—	—	—	—	—	—	—	—	—	—	—	—	—	xxxx
		15:0	SEC10<3:0>	—	—	—	—	—	—	—	—	—	—	—	—	—	—	—	xxxx
0230	RTCDATE	31:16	YEAR10<3:0>	—	—	—	—	—	—	—	—	—	—	—	—	—	—	—	xxxx
		15:0	DAY10<3:0>	—	—	—	—	—	—	—	—	—	—	—	—	—	—	—	xxxx
0240	ALRMTIME	31:16	HR10<3:0>	—	—	—	—	—	—	—	—	—	—	—	—	—	—	—	xxxx
		15:0	SEC10<3:0>	—	—	—	—	—	—	—	—	—	—	—	—	—	—	—	xxxx
0250	ALRMDATE	31:16	—	—	—	—	—	—	—	—	—	—	—	—	—	—	—	—	00xx
		15:0	DAY10<3:0>	—	—	—	—	—	—	—	—	—	—	—	—	—	—	—	xx0x

Legend: x = unknown value on Reset; — = unimplemented, read as '0'. Reset values are shown in hexadecimal.

Note 1: All registers in this table have corresponding CLR, SET and INV registers at its virtual address, plus an offset of 0x4, 0x8 and 0xC, respectively. See Section 12.1.1 "CLR, SET and INV Registers" for more information.

TABLE 4-45:

CAN1 REGISTER SUMMARY FOR PIC32MX534F064H, PIC32MX564F064H, PIC32MX564F128H, PIC32MX564F256H, PIC32MX575F512H, PIC32MX764F128H, PIC32MX775F256H, PIC32MX795F512H, PIC32MX795F512H, PIC32MX534F064L, PIC32MX564F064L, PIC32MX564F128L, PIC32MX564F128L, PIC32MX575F512L, PIC32MX764F128L, PIC32MX764F128L, PIC32MX775F256L, PIC32MX775F512L AND PIC32MX795F512L DEVICES⁽¹⁾

Virtual Address (BF8 #)	Register Name	Bit Range	Bits													All Resets				
			31/15	30/14	29/13	28/12	27/11	26/10	25/9	24/8	23/7	22/6	21/5	20/4	19/3	18/2	17/1	16/0		
B000	C1CON	31:16	—	—	—	—	ABAT	—	REQOP<2:0>	—	—	OPMOD<2:0>	—	CANCAP	—	—	—	—	0480	
		15:0	ON	FRZ	SIDLE	—	CANBUSY	—	—	—	—	WAKFIL	—	—	—	—	—	—	0000	
B010	C1CFG	31:16	—	—	—	—	—	—	—	—	—	—	—	—	—	—	—	—	0000	
		15:0	SEG2PHTS	SAM	—	SEG1PH<2:0>	—	—	PRSEG<2:0>	—	—	SJW<1:0>	—	—	BRP<5:0>	—	—	—	0000	
B020	C1INT	31:16	IVRIE	WAKIE	CERRIE	SERRIE	RBOVIE	—	—	—	—	—	—	—	MODIE	CTMRIE	RBIE	TBIE	0000	
		15:0	IVRIF	WAKIF	CERRIF	SERRIF	RBOVIF	—	—	—	—	—	—	—	MODIF	CTMRIF	RBIF	TBIF	0000	
B030	C1VEC	31:16	—	—	—	—	—	—	—	—	—	—	—	—	—	—	—	—	0000	
		15:0	—	—	—	—	—	FILHIT<4:0>	—	—	—	—	—	—	—	—	—	—	0040	
B040	C1TREC	31:16	—	—	—	—	—	—	—	—	—	—	—	—	—	—	—	—	0000	
		15:0	—	—	—	—	—	—	—	—	—	—	—	—	—	—	—	—	0000	
B050	C1FSTAT	31:16	FIFOIP31	FIFOIP30	FIFOIP29	FIFOIP28	FIFOIP27	FIFOIP26	FIFOIP25	FIFOIP24	FIFOIP23	FIFOIP22	FIFOIP21	FIFOIP20	FIFOIP19	FIFOIP18	FIFOIP17	FIFOIP16	0000	
		15:0	FIFOIP15	FIFOIP14	FIFOIP13	FIFOIP12	FIFOIP11	FIFOIP10	FIFOIP9	FIFOIP8	FIFOIP7	FIFOIP6	FIFOIP5	FIFOIP4	FIFOIP3	FIFOIP2	FIFOIP1	FIFOIP0	0000	
B060	C1RXOVF	31:16	RXOVF31	RXOVF30	RXOVF29	RXOVF28	RXOVF27	RXOVF26	RXOVF25	RXOVF24	RXOVF23	RXOVF22	RXOVF21	RXOVF20	RXOVF19	RXOVF18	RXOVF17	RXOVF16	0000	
		15:0	RXOVF15	RXOVF14	RXOVF13	RXOVF12	RXOVF11	RXOVF10	RXOVF9	RXOVF8	RXOVF7	RXOVF6	RXOVF5	RXOVF4	RXOVF3	RXOVF2	RXOVF1	RXOVF0	0000	
B070	C1TMR	31:16	CANTS<15:0>													0000				
		15:0	CANTSPRE<15:0>													0000				
B080	C1RXM0	31:16	SID<10:0>													—	MIDE	—	EID<17:16>	xxxx
		15:0	EID<15:0>													—	—	—	—	xxxx
B090	C1RXM1	31:16	SID<10:0>													—	MIDE	—	EID<17:16>	xxxx
		15:0	EID<15:0>													—	—	—	—	xxxx
B0A0	C1RXM2	31:16	SID<10:0>													—	MIDE	—	EID<17:16>	xxxx
		15:0	EID<15:0>													—	—	—	—	xxxx
B0B0	C1RXM3	31:16	SID<10:0>													—	MIDE	—	EID<17:16>	xxxx
		15:0	EID<15:0>													—	—	—	—	xxxx
B0C0	C1FLTCON0	31:16	FLTEN3	MSEL3<1:0>	—	—	—	FSEL3<4:0>	—	—	FLTEN2	MSEL2<1:0>	—	—	FSEL2<4:0>	—	—	—	0000	
		15:0	FLTEN1	MSEL1<1:0>	—	—	—	FSEL1<4:0>	—	—	FLTEN0	MSEL0<1:0>	—	—	FSEL0<4:0>	—	—	—	0000	
B0D0	C1FLTCON1	31:16	FLTEN7	MSEL7<1:0>	—	—	—	FSEL7<4:0>	—	—	FLTEN6	MSEL6<1:0>	—	—	FSEL6<4:0>	—	—	—	0000	
		15:0	FLTEN5	MSEL5<1:0>	—	—	—	FSEL5<4:0>	—	—	FLTEN4	MSEL4<1:0>	—	—	FSEL4<4:0>	—	—	—	0000	
B0E0	C1FLTCON2	31:16	FLTEN11	MSEL11<1:0>	—	—	—	FSEL11<4:0>	—	—	FLTEN10	MSEL10<1:0>	—	—	FSEL10<4:0>	—	—	—	0000	
		15:0	FLTEN9	MSEL9<1:0>	—	—	—	FSEL9<4:0>	—	—	FLTEN8	MSEL8<1:0>	—	—	FSEL8<4:0>	—	—	—	0000	
B0F0	C1FLTCON3	31:16	FLTEN15	MSEL15<1:0>	—	—	—	FSEL15<4:0>	—	—	FLTEN14	MSEL14<1:0>	—	—	FSEL14<4:0>	—	—	—	0000	
		15:0	FLTEN13	MSEL13<1:0>	—	—	—	FSEL13<4:0>	—	—	FLTEN12	MSEL12<1:0>	—	—	FSEL12<4:0>	—	—	—	0000	

Legend: x = unknown value on Reset; — = unimplemented, read as '0'. Reset values are shown in hexadecimal.
Note 1: All registers in this table have corresponding CLR, SET and INV registers at their virtual addresses, plus offsets of 0x4, 0x8 and 0xC, respectively. See Section 12.1.1 "CLR, SET and INV Registers" for more information.

TABLE 4-45:

CAN1 REGISTER SUMMARY FOR PIC32MX534F064H, PIC32MX564F064H, PIC32MX564F128H, PIC32MX575F256H, PIC32MX575F512H, PIC32MX764F128H, PIC32MX775F256H, PIC32MX795F512H, PIC32MX534F064L, PIC32MX564F064L, PIC32MX564F128L, PIC32MX575F256L, PIC32MX575F512L, PIC32MX764F128L, PIC32MX775F256L, PIC32MX775F512L AND PIC32MX795F512L DEVICES⁽¹⁾ (CONTINUED)

Virtual Address (BF8 #)	Register Name	Bit Range	Bits																All Resets	
			31/15	30/14	29/13	28/12	27/11	26/10	25/9	24/8	23/7	22/6	21/5	20/4	19/3	18/2	17/1	16/0		
B100	C1FLTCON4	31:16	FLTEN19	MSEL19<1:0>	FSEL19<4:0>									FLTEN18	MSEL18<1:0>	FSEL18<4:0>				0000
		15:0	FLTEN17	MSEL17<1:0>	FSEL17<4:0>									FLTEN16	MSEL16<1:0>	FSEL16<4:0>				0000
B110	C1FLTCON5	31:16	FLTEN23	MSEL23<1:0>	FSEL23<4:0>									FLTEN22	MSEL22<1:0>	FSEL22<4:0>				0000
		15:0	FLTEN21	MSEL21<1:0>	FSEL21<4:0>									FLTEN20	MSEL20<1:0>	FSEL20<4:0>				0000
B120	C1FLTCON6	31:16	FLTEN27	MSEL27<1:0>	FSEL27<4:0>									FLTEN26	MSEL26<1:0>	FSEL26<4:0>				0000
		15:0	FLTEN25	MSEL25<1:0>	FSEL25<4:0>									FLTEN24	MSEL24<1:0>	FSEL24<4:0>				0000
B130	C1FLTCON7	31:16	FLTEN31	MSEL31<1:0>	FSEL31<4:0>									FLTEN30	MSEL30<1:0>	FSEL30<4:0>				0000
		15:0	FLTEN29	MSEL29<1:0>	FSEL29<4:0>									FLTEN28	MSEL28<1:0>	FSEL28<4:0>				0000
B140	C1RXFn (n = 0-31)	31:16			SID<10:0>											EXID			EID<17:16>	xxxx
		15:0																		xxxx
B340	C1FIFOB	31:16																		0000
		15:0																		0000
B350	C1FIFOCn (n = 0-31)	31:16																		0000
		15:0																		0000
B360	C1FIFOCn (n = 0-31)	31:16																		0000
		15:0																		0000
B370	C1FIFOUAn (n = 0-31)	31:16																		0000
		15:0																		0000
B380	C1FIFOCIn (n = 0-31)	31:16																		0000
		15:0																		0000

Legend: x = unknown value on Reset; — = unimplemented, read as '0'. Reset values are shown in hexadecimal.
Note 1: All registers in this table have corresponding CLR, SET and INV registers at their virtual addresses, plus offsets of 0x4, 0x8 and 0xC, respectively. See [Section 12.1.1 "CLR, SET and INV Registers"](#) for more information.

TABLE 4-46: CAN2 REGISTER SUMMARY FOR PIC32MX775F256H, PIC32MX775F512H, PIC32MX795F512H, PIC32MX775F256L, PIC32MX775F512L AND PIC32MX795F512L DEVICES⁽¹⁾

Virtual Address (BF88 #)	Register Name	Bit Range	31/15	30/14	29/13	28/12	27/11	26/10	25/9	24/8	23/7	22/6	21/5	20/4	19/3	18/2	17/1	16/0	All Resets
C000	C2CON	31:16	—	—	—	—	ABAT	REQOP<2:0>	—	—	OPMOD<2:0>	—	—	CANCAP	—	—	—	—	0480
		15:0	ON	FRZ	SIDL	—	CANBUSY	—	—	—	—	WAKFIL	—	—	DNCNT<4:0>			0000	
C010	C2CFG	31:16	—	—	—	—	—	—	—	—	—	—	—	—	SEG2PH<2:0>			0000	
		15:0	SEG2PHTS	SAM	—	—	—	—	—	—	—	—	—	—	BRP<5:0>			0000	
C020	C2INT	31:16	IVRIE	WAKIE	CERRIE	SERRIE	RBOVIE	—	—	—	—	—	—	—	MODIE	CTMRIE	RBIE	TBIE	0000
		15:0	IVRIF	WAKIF	CERRIF	SERRIF	RBOVIF	—	—	—	—	—	—	—	MODIF	CTMRIF	RBIF	TBIF	0000
C030	C2VEC	31:16	—	—	—	—	—	—	—	—	—	—	—	—	—	—	—	—	0000
		15:0	—	—	—	—	—	FILHIT<4:0>	—	—	—	—	—	—	ICODE<6:0>			0040	
C040	C2TREC	31:16	—	—	—	—	—	—	—	—	—	—	TXBO	TXBP	RXBP	TXWARN	RXWARN	EWARN	0000
		15:0	—	—	—	—	TERRCNT<7:0>	—	—	—	—	—	—	—	RERRCNT<7:0>			0000	
C050	C2FSTAT	31:16	FIFOIP31	FIFOIP30	FIFOIP29	FIFOIP28	FIFOIP27	FIFOIP26	FIFOIP25	FIFOIP24	FIFOIP23	FIFOIP22	FIFOIP21	FIFOIP20	FIFOIP19	FIFOIP18	FIFOIP17	FIFOIP16	0000
		15:0	FIFOIP15	FIFOIP14	FIFOIP13	FIFOIP12	FIFOIP11	FIFOIP10	FIFOIP9	FIFOIP8	FIFOIP7	FIFOIP6	FIFOIP5	FIFOIP4	FIFOIP3	FIFOIP2	FIFOIP1	FIFOIP0	0000
C060	C2RXOVF	31:16	RXOVF31	RXOVF30	RXOVF29	RXOVF28	RXOVF27	RXOVF26	RXOVF25	RXOVF24	RXOVF23	RXOVF22	RXOVF21	RXOVF20	RXOVF19	RXOVF18	RXOVF17	RXOVF16	0000
		15:0	RXOVF15	RXOVF14	RXOVF13	RXOVF12	RXOVF11	RXOVF10	RXOVF9	RXOVF8	RXOVF7	RXOVF6	RXOVF5	RXOVF4	RXOVF3	RXOVF2	RXOVF1	RXOVF0	0000
C070	C2TMR	31:16	—	—	—	—	—	—	—	—	—	—	—	—	CANTS<15:0>			0000	
		15:0	—	—	—	—	—	—	—	—	—	—	—	—	CANTS<15:0>			0000	
C080	C2RXM0	31:16	—	—	—	—	—	SID<10:0>	—	—	—	—	—	—	MIDE	—	EID<17:16>	—	xxxx
		15:0	—	—	—	—	—	—	—	—	—	—	—	—	—	—	—	—	xxxx
C0A0	C2RXM1	31:16	—	—	—	—	—	SID<10:0>	—	—	—	—	—	—	MIDE	—	EID<17:16>	—	xxxx
		15:0	—	—	—	—	—	—	—	—	—	—	—	—	—	—	—	—	xxxx
C0B0	C2RXM2	31:16	—	—	—	—	—	SID<10:0>	—	—	—	—	—	—	MIDE	—	EID<17:16>	—	xxxx
		15:0	—	—	—	—	—	—	—	—	—	—	—	—	—	—	—	—	xxxx
C0B0	C2RXM3	31:16	—	—	—	—	—	SID<10:0>	—	—	—	—	—	—	MIDE	—	EID<17:16>	—	xxxx
		15:0	—	—	—	—	—	—	—	—	—	—	—	—	—	—	—	—	xxxx
C0C0	C2FLTCO0	31:16	FLTEN3	MSEL3<1:0>	FLTEN2	—	—	FSEL3<4:0>	—	—	—	MSEL2<1:0>	—	—	—	FSEL2<4:0>	—	—	0000
		15:0	FLTEN1	MSEL1<1:0>	FLTEN0	—	—	FSEL1<4:0>	—	—	—	MSEL0<1:0>	—	—	—	FSEL0<4:0>	—	—	0000
C0D0	C2FLTCO1	31:16	FLTEN7	MSEL7<1:0>	FLTEN6	—	—	FSEL7<4:0>	—	—	—	MSEL6<1:0>	—	—	—	FSEL6<4:0>	—	—	0000
		15:0	FLTEN5	MSEL5<1:0>	FLTEN4	—	—	FSEL5<4:0>	—	—	—	MSEL4<1:0>	—	—	—	FSEL4<4:0>	—	—	0000
C0E0	C2FLTCO2	31:16	FLTEN11	MSEL11<1:0>	FLTEN10	—	—	FSEL11<4:0>	—	—	—	MSEL10<1:0>	—	—	—	FSEL10<4:0>	—	—	0000
		15:0	FLTEN9	MSEL9<1:0>	FLTEN8	—	—	FSEL9<4:0>	—	—	—	MSEL8<1:0>	—	—	—	FSEL8<4:0>	—	—	0000
C0F0	C2FLTCO3	31:16	FLTEN15	MSEL15<1:0>	FLTEN14	—	—	FSEL15<4:0>	—	—	—	MSEL14<1:0>	—	—	—	FSEL14<4:0>	—	—	0000
		15:0	FLTEN13	MSEL13<1:0>	FLTEN12	—	—	FSEL13<4:0>	—	—	—	MSEL12<1:0>	—	—	—	FSEL12<4:0>	—	—	0000

Legend: x = unknown value on Reset; — = unimplemented; read as '0'. Reset values are shown in hexadecimal.
Note 1: All registers in this table have corresponding CLR, SET and INV registers at their virtual addresses, plus offsets of 0x4, 0x8 and 0xC, respectively. See Section 12.1.1 "CLR, SET and INV Registers" for more information.

TABLE 4-46: CAN2 REGISTER SUMMARY FOR PIC32MX775F256H, PIC32MX775F512H, PIC32MX795F512H, PIC32MX775F512H, PIC32MX775F512H, PIC32MX775F512H, PIC32MX775F512H, PIC32MX775F512H, PIC32MX775F512L AND PIC32MX795F512L DEVICES⁽¹⁾ (CONTINUED)

Virtual Address (BF88 _n)	Register Name	Bit Range	Bits																All Resets
			31/15	30/14	29/13	28/12	27/11	26/10	25/9	24/8	23/7	22/6	21/5	20/4	19/3	18/2	17/1	16/0	
C100	C2FLTCO4n	31:16	FLTEN19	MSEL19<1:0>	FSEL19<4:0>													FSEL18<4:0>	0000
		15:0	FLTEN17	MSEL17<1:0>	FSEL17<4:0>													FSEL16<4:0>	0000
C110	C2FLTCO5n	31:16	FLTEN23	MSEL23<1:0>	FSEL23<4:0>													FSEL22<4:0>	0000
		15:0	FLTEN21	MSEL21<1:0>	FSEL21<4:0>													FSEL20<4:0>	0000
C120	C2FLTCO6n	31:16	FLTEN27	MSEL27<1:0>	FSEL27<4:0>													FSEL26<4:0>	0000
		15:0	FLTEN25	MSEL25<1:0>	FSEL25<4:0>													FSEL24<4:0>	0000
C130	C2FLTCO7n	31:16	FLTEN31	MSEL31<1:0>	FSEL31<4:0>													FSEL30<4:0>	0000
		15:0	FLTEN29	MSEL29<1:0>	FSEL29<4:0>													FSEL28<4:0>	0000
C140	C2RXFn (n = 0-31)	31:16			SID<10:0>												EXID	EID<17:16>	xxxx
		15:0																	xxxx
C340	C2FIFOBA	31:16																	0000
		15:0																	0000
C350	C2FIFOCOn (n = 0-31)	31:16																	0000
		15:0																	0000
C360	C2FIFOINTn (n = 0-31)	31:16																	0000
		15:0																	0000
C370	C2FIFOUAn (n = 0-31)	31:16																	0000
		15:0																	0000
C380	C2FIFOCIn (n = 0-31)	31:16																	0000
		15:0																	0000

Legend: x = unknown value on Reset; — = unimplemented; read as '0'. Reset values are shown in hexadecimal.
Note 1: All registers in this table have corresponding CLR, SET and INV registers at their virtual addresses, plus offsets of 0x4, 0x8 and 0xC, respectively. See Section 12.1.1 "CLR, SET and INV Registers" for more information.

TABLE 4-47: ETHERNET CONTROLLER REGISTER SUMMARY FOR PIC32MX664F064H, PIC32MX664F128H, PIC32MX664F064L, PIC32MX664F128L, PIC32MX675F256H, PIC32MX675F512H, PIC32MX695F512H, PIC32MX775F256H, PIC32MX775F512H, PIC32MX795F512H, PIC32MX675F256L, PIC32MX675F512L, PIC32MX764F128H, PIC32MX764F128L, PIC32MX775F256L, PIC32MX775F512L AND PIC32MX795F512L DEVICES⁽¹⁾

Virtual Address	Register Name	Bit Range	31/15	30/14	29/13	28/12	27/11	26/10	25/9	24/8	23/7	22/6	21/5	20/4	19/3	18/2	17/1	16/0	All Resets
9000	ETHCON1	31:16	ON	FRZ	SIDL	TXRTS	RXEN	AUTOFC	MANFC										0000
9010	ETHCON2	31:16	—	—	—	—	—	—	—	—	—	—	—	—	—	—	—	—	0000
9020	ETHXST	31:16	—	—	—	—	—	—	—	—	—	—	—	—	—	—	—	—	0000
9030	ETHRXST	31:16	—	—	—	—	—	—	—	—	—	—	—	—	—	—	—	—	0000
9040	ETHHT0	31:16	—	—	—	—	—	—	—	—	—	—	—	—	—	—	—	—	0000
9050	ETHHT1	31:16	—	—	—	—	—	—	—	—	—	—	—	—	—	—	—	—	0000
9060	ETHPMM0	31:16	—	—	—	—	—	—	—	—	—	—	—	—	—	—	—	—	0000
9070	ETHPMM1	31:16	—	—	—	—	—	—	—	—	—	—	—	—	—	—	—	—	0000
9080	ETHPMCS	31:16	—	—	—	—	—	—	—	—	—	—	—	—	—	—	—	—	0000
9090	ETHPMO	31:16	—	—	—	—	—	—	—	—	—	—	—	—	—	—	—	—	0000
90A0	ETHRXFC	31:16	HTEN	MPEN	NOTPM	PMODE<3:0>	CRC ERREN	CRC OKEN	RUNT ERREN	RUNTEN	UCEN	NOT MEEN	MCEN	BCEN					0000
90B0	ETHRXWM	31:16	—	—	—	—	—	—	—	—	—	—	—	—	—	—	—	—	0000
90C0	ETHIEN	31:16	TX BUSEIE	RX BUSEIE	TX BUSEIE	FW MARKIE	RX MARKIE	RX DONIE	PK TPENDIE	RX ACTIE	TX DONEIE	TX ABORTIE	RX BUFNAIE	TX OVFLOWIE					0000
90D0	ETHIRQ	31:16	TXBUSE	RXBUSE	EVMARK	FVWMARK	RXDONE	PKTPEND	RXACT	TXDONE	TXABORT	RXBUFNA	RXOVFLW						0000

Legend: x = unknown value on Reset; — = unimplemented; read as '0'. Reset values are shown in hexadecimal.
Note 1: All registers in this table (with the exception of ETHSTAT) have corresponding CLR, SET and INV registers at their virtual addresses, plus offsets of 0x4, 0x8 and 0xC, respectively. See [Section 12.1.1 "CLR, SET and INV Registers"](#) for more information.
Note 2: Reset values default to the factory programmed value.

TABLE 4-47:

ETHERNET CONTROLLER REGISTER SUMMARY FOR PIC32MX664F064H, PIC32MX664F128H, PIC32MX664F064L, PIC32MX664F128L, PIC32MX675F256H, PIC32MX675F512H, PIC32MX695F512H, PIC32MX775F256H, PIC32MX775F512H, PIC32MX795F512H, PIC32MX695F512L, PIC32MX675F256L, PIC32MX675F512L, PIC32MX764F128H, PIC32MX764F128L, PIC32MX775F256L, PIC32MX775F512L AND PIC32MX795F512L DEVICES⁽¹⁾ (CONTINUED)

Virtual Address (BF88_#)	Register Name	Bit Range	Bits																All Resets
			31/15	30/14	29/13	28/12	27/11	26/10	25/9	24/8	23/7	22/6	21/5	20/4	19/3	18/2	17/1	16/0	
90E0	ETHSTAT	31:16	—	—	—	—	—	—	—	—	—	—	—	—	—	—	—	—	0000
		15:0	—	—	—	—	—	—	—	—	—	—	—	—	—	—	—	—	0000
9100	ETH RXOVFLOW	31:16	—	—	—	—	—	—	—	—	—	—	—	—	—	—	—	—	0000
		15:0	—	—	—	—	—	—	—	—	—	—	—	—	—	—	—	—	0000
9110	ETH FRMTXOK	31:16	—	—	—	—	—	—	—	—	—	—	—	—	—	—	—	—	0000
		15:0	—	—	—	—	—	—	—	—	—	—	—	—	—	—	—	—	0000
9120	ETH SCOLFRM	31:16	—	—	—	—	—	—	—	—	—	—	—	—	—	—	—	—	0000
		15:0	—	—	—	—	—	—	—	—	—	—	—	—	—	—	—	—	0000
9130	ETH MCOLFRM	31:16	—	—	—	—	—	—	—	—	—	—	—	—	—	—	—	—	0000
		15:0	—	—	—	—	—	—	—	—	—	—	—	—	—	—	—	—	0000
9140	ETH FRMRXOK	31:16	—	—	—	—	—	—	—	—	—	—	—	—	—	—	—	—	0000
		15:0	—	—	—	—	—	—	—	—	—	—	—	—	—	—	—	—	0000
9150	ETH FCSERR	31:16	—	—	—	—	—	—	—	—	—	—	—	—	—	—	—	—	0000
		15:0	—	—	—	—	—	—	—	—	—	—	—	—	—	—	—	—	0000
9160	ETH ALGNERR	31:16	—	—	—	—	—	—	—	—	—	—	—	—	—	—	—	—	0000
		15:0	—	—	—	—	—	—	—	—	—	—	—	—	—	—	—	—	0000
9200	EMAC1 CFG1	31:16	—	—	—	—	—	—	—	—	—	—	—	—	—	—	—	—	0000
		15:0	SOFT RESET	—	—	—	—	RESET RMCS	—	—	—	—	RESET RFUN	—	—	—	—	—	800D
9210	EMAC1 CFG2	31:16	—	—	—	—	—	—	—	—	—	—	—	—	—	—	—	—	0000
		15:0	—	EXCESS DFR	—	—	—	—	—	—	—	—	—	—	—	—	—	—	0000
9220	EMAC1 IPGT	31:16	—	—	—	—	—	—	—	—	—	—	—	—	—	—	—	—	0000
		15:0	—	—	—	—	—	—	—	—	—	—	—	—	—	—	—	—	0012
9230	EMAC1 IPGR	31:16	—	—	—	—	—	—	—	—	—	—	—	—	—	—	—	—	0000
		15:0	—	—	—	—	—	—	—	—	—	—	—	—	—	—	—	—	0000
9240	EMAC1 CLRT	31:16	—	—	—	—	—	—	—	—	—	—	—	—	—	—	—	—	0000
		15:0	—	—	—	—	—	—	—	—	—	—	—	—	—	—	—	—	370F
9250	EMAC1 MAXF	31:16	—	—	—	—	—	—	—	—	—	—	—	—	—	—	—	—	0000
		15:0	—	—	—	—	—	—	—	—	—	—	—	—	—	—	—	—	05EE

Legend: x = unknown value on Reset; — = unimplemented, read as '0'. Reset values are shown in hexadecimal.

Note 1: All registers in this table (with the exception of ETHSTAT) have corresponding CLR, SET and INV registers at their virtual addresses, plus offsets of 0x4, 0x8 and 0xC, respectively. See [Section 12.1.1 "CLR, SET and INV Registers"](#) for more information.

Note 2: Reset values default to the factory programmed value.

TABLE 4-47:

ETHERNET CONTROLLER REGISTER SUMMARY FOR PIC32MX664F064H, PIC32MX664F128H, PIC32MX664F064L, PIC32MX664F128L, PIC32MX675F256H, PIC32MX675F512H, PIC32MX695F512H, PIC32MX775F256H, PIC32MX775F512H, PIC32MX795F512H, PIC32MX695F512L, PIC32MX675F256L, PIC32MX675F512L, PIC32MX764F128H, PIC32MX764F128L, PIC32MX775F256L, PIC32MX775F512L AND PIC32MX795F512L DEVICES⁽¹⁾ (CONTINUED)

Virtual Address (BF88 #)	Register Name	Bit Range	Bits															All Resets
			31/15	30/14	29/13	28/12	27/11	26/10	25/9	24/8	23/7	22/6	21/5	20/4	19/3	18/2	17/1	
9260	EMAC1 SUPP	31:16 15:0	—	—	—	—	—	—	—	—	—	—	—	—	—	—	—	0000
9270	EMAC1 TEST	31:16 15:0	—	—	—	—	—	—	—	—	—	—	—	—	—	—	—	1000
9280	EMAC1 MCFG	31:16 15:0	—	—	—	—	—	—	—	—	—	—	—	—	—	—	—	0000
9290	EMAC1 MCMD	31:16 15:0	—	—	—	—	—	—	—	—	—	—	—	—	—	—	—	0000
92A0	EMAC1 MADR	31:16 15:0	—	—	—	—	—	—	—	—	—	—	—	—	—	—	—	0000
92B0	EMAC1 MWTD	31:16 15:0	—	—	—	—	—	—	—	—	—	—	—	—	—	—	—	0100
92C0	EMAC1 MRDD	31:16 15:0	—	—	—	—	—	—	—	—	—	—	—	—	—	—	—	0000
92D0	EMAC1 MIND	31:16 15:0	—	—	—	—	—	—	—	—	—	—	—	—	—	—	—	0000
9300	EMAC1 SA0(2)	31:16 15:0	—	—	—	—	—	—	—	—	—	—	—	—	—	—	—	0000
9310	EMAC1 SA1(4)	31:16 15:0	—	—	—	—	—	—	—	—	—	—	—	—	—	—	—	0000
9320	EMAC1 SA2(4)	31:16 15:0	—	—	—	—	—	—	—	—	—	—	—	—	—	—	—	0000

x = unknown value on Reset; — = unimplemented, read as '0'. Reset values are shown in hexadecimal.

Note 1: All registers in this table (with the exception of ETHSTAT) have corresponding CLR, SET and INV registers at their virtual addresses, plus offsets of 0x4, 0x8 and 0xC, respectively. See Section 12.1.1 "CLR, SET and INV Registers" for more information.

Note 2: Reset values default to the factory programmed value.

5.0 FLASH PROGRAM MEMORY

Note 1: This data sheet summarizes the features of the PIC32MX5XX/6XX/7XX family of devices. It is not intended to be a comprehensive reference source. To complement the information in this data sheet, refer to **Section 5. “Flash Program Memory”** (DS61121) in the *“PIC32 Family Reference Manual”*, which is available from the Microchip web site (www.microchip.com/PIC32).

2: Some registers and associated bits described in this section may not be available on all devices. Refer to **Section 4.0 “Memory Organization”** in this data sheet for device-specific register and bit information.

PIC32MX5XX/6XX/7XX devices contain an internal Flash program memory for executing user code. There are three methods by which the user can program this memory:

1. Run-Time Self-Programming (RTSP)
2. EJTAG Programming
3. In-Circuit Serial Programming™ (ICSP™)

RTSP is performed by software executing from either Flash or RAM memory. Information about RTSP techniques is available in **Section 5. “Flash Program Memory”** (DS61121) in the *“PIC32 Family Reference Manual”*.

EJTAG is performed using the EJTAG port of the device and an EJTAG capable programmer.

ICSP is performed using a serial data connection to the device and allows much faster programming times than RTSP.

The EJTAG and ICSP methods are described in the *“PIC32 Flash Programming Specification”* (DS61145), which can be downloaded from the Microchip web site.

NOTES:

6.0 RESETS

Note 1: This data sheet summarizes the features of the PIC32MX5XX/6XX/7XX family of devices. It is not intended to be a comprehensive reference source. To complement the information in this data sheet, refer to **Section 7. “Resets”** (DS61118) in the “PIC32 Family Reference Manual”, which is available from the Microchip web site (www.microchip.com/PIC32).

2: Some registers and associated bits described in this section may not be available on all devices. Refer to **Section 4.0 “Memory Organization”** in this data sheet for device-specific register and bit information.

The Reset module combines all Reset sources and controls the device Master Reset signal, SYSRST. The following is a list of device Reset sources:

- POR: Power-on Reset
- $\overline{\text{MCLR}}$: Master Clear Reset pin
- SWR: Software Reset
- WDTR: Watchdog Timer Reset
- BOR: Brown-out Reset
- CMR: Configuration Mismatch Reset

A simplified block diagram of the Reset module is illustrated in [Figure 6-1](#).

FIGURE 6-1: SYSTEM RESET BLOCK DIAGRAM

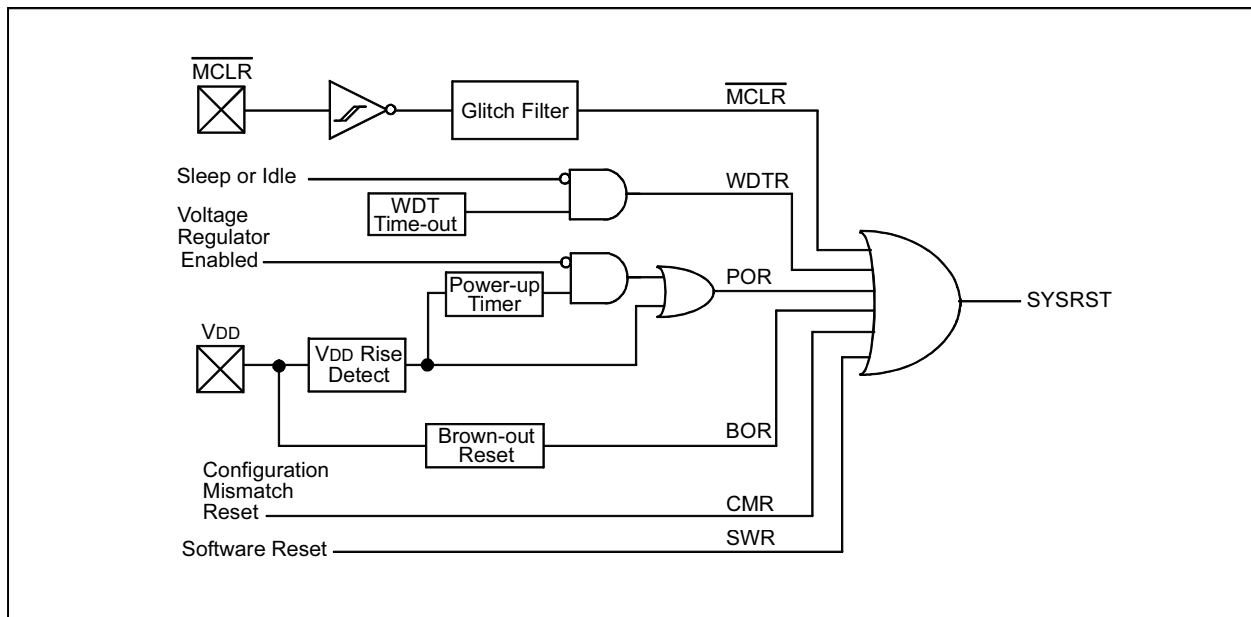

NOTES:

7.0 INTERRUPT CONTROLLER

Note 1: This data sheet summarizes the features of the PIC32MX5XX/6XX/7XX family of devices. It is not intended to be a comprehensive reference source. To complement the information in this data sheet, refer to **Section 8. “Interrupts”** (DS61108) in the *“PIC32 Family Reference Manual”*, which is available from the Microchip web site (www.microchip.com/PIC32).

2: Some registers and associated bits described in this section may not be available on all devices. Refer to **Section 4.0 “Memory Organization”** in this data sheet for device-specific register and bit information.

PIC32MX5XX/6XX/7XX devices generate interrupt requests in response to interrupt events from peripheral modules. The interrupt control module exists externally to the CPU logic and prioritizes the interrupt events before presenting them to the CPU.

The PIC32MX5XX/6XX/7XX interrupt module includes the following features:

- Up to 96 interrupt sources
- Up to 64 interrupt vectors
- Single and multi-vector mode operations
- Five external interrupts with edge polarity control
- Interrupt proximity timer
- Module freeze in Debug mode
- Seven user-selectable priority levels for each vector
- Four user-selectable subpriority levels within each priority
- Dedicated shadow set for user-selectable priority level
- Software can generate any interrupt
- User-configurable interrupt vector table location
- User-configurable interrupt vector spacing

A simplified block diagram of the Interrupt Controller module is illustrated in [Figure 7-1](#).

FIGURE 7-1: INTERRUPT CONTROLLER MODULE

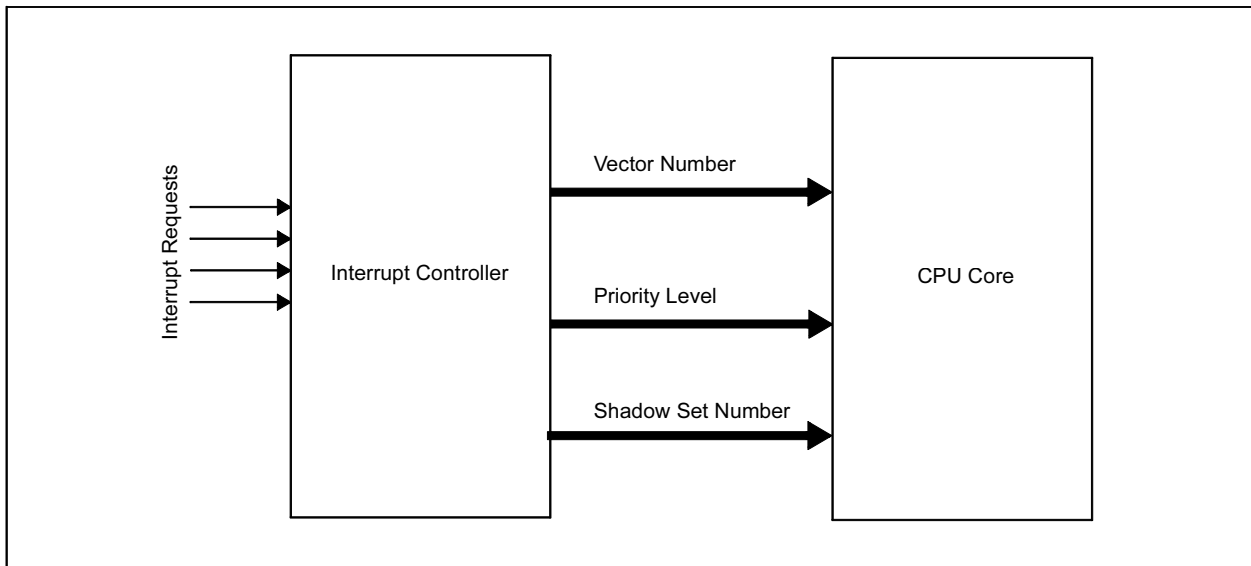

PIC32MX5XX/6XX/7XX

TABLE 7-1: INTERRUPT IRQ, VECTOR AND BIT LOCATION

Interrupt Source ⁽¹⁾	IRQ	Vector Number	Interrupt Bit Location			
			Flag	Enable	Priority	Sub-Priority
Highest Natural Order Priority						
CT – Core Timer Interrupt	0	0	IFS0<0>	IEC0<0>	IPC0<4:2>	IPC0<1:0>
CS0 – Core Software Interrupt 0	1	1	IFS0<1>	IEC0<1>	IPC0<12:10>	IPC0<9:8>
CS1 – Core Software Interrupt 1	2	2	IFS0<2>	IEC0<2>	IPC0<20:18>	IPC0<17:16>
INT0 – External Interrupt 0	3	3	IFS0<3>	IEC0<3>	IPC0<28:26>	IPC0<25:24>
T1 – Timer1	4	4	IFS0<4>	IEC0<4>	IPC1<4:2>	IPC1<1:0>
IC1 – Input Capture 1	5	5	IFS0<5>	IEC0<5>	IPC1<12:10>	IPC1<9:8>
OC1 – Output Compare 1	6	6	IFS0<6>	IEC0<6>	IPC1<20:18>	IPC1<17:16>
INT1 – External Interrupt 1	7	7	IFS0<7>	IEC0<7>	IPC1<28:26>	IPC1<25:24>
T2 – Timer2	8	8	IFS0<8>	IEC0<8>	IPC2<4:2>	IPC2<1:0>
IC2 – Input Capture 2	9	9	IFS0<9>	IEC0<9>	IPC2<12:10>	IPC2<9:8>
OC2 – Output Compare 2	10	10	IFS0<10>	IEC0<10>	IPC2<20:18>	IPC2<17:16>
INT2 – External Interrupt 2	11	11	IFS0<11>	IEC0<11>	IPC2<28:26>	IPC2<25:24>
T3 – Timer3	12	12	IFS0<12>	IEC0<12>	IPC3<4:2>	IPC3<1:0>
IC3 – Input Capture 3	13	13	IFS0<13>	IEC0<13>	IPC3<12:10>	IPC3<9:8>
OC3 – Output Compare 3	14	14	IFS0<14>	IEC0<14>	IPC3<20:18>	IPC3<17:16>
INT3 – External Interrupt 3	15	15	IFS0<15>	IEC0<15>	IPC3<28:26>	IPC3<25:24>
T4 – Timer4	16	16	IFS0<16>	IEC0<16>	IPC4<4:2>	IPC4<1:0>
IC4 – Input Capture 4	17	17	IFS0<17>	IEC0<17>	IPC4<12:10>	IPC4<9:8>
OC4 – Output Compare 4	18	18	IFS0<18>	IEC0<18>	IPC4<20:18>	IPC4<17:16>
INT4 – External Interrupt 4	19	19	IFS0<19>	IEC0<19>	IPC4<28:26>	IPC4<25:24>
T5 – Timer5	20	20	IFS0<20>	IEC0<20>	IPC5<4:2>	IPC5<1:0>
IC5 – Input Capture 5	21	21	IFS0<21>	IEC0<21>	IPC5<12:10>	IPC5<9:8>
OC5 – Output Compare 5	22	22	IFS0<22>	IEC0<22>	IPC5<20:18>	IPC5<17:16>
SPI1E – SPI1 Fault	23	23	IFS0<23>	IEC0<23>	IPC5<28:26>	IPC5<25:24>
SPI1RX – SPI1 Receive Done	24	23	IFS0<24>	IEC0<24>	IPC5<28:26>	IPC5<25:24>
SPI1TX – SPI1 Transfer Done	25	23	IFS0<25>	IEC0<25>	IPC5<28:26>	IPC5<25:24>
U1E – UART1 Error	26	24	IFS0<26>	IEC0<26>	IPC6<4:2>	IPC6<1:0>
SPI3E – SPI3 Fault						
I2C3B – I2C3 Bus Collision Event						
U1RX – UART1 Receiver	27	24	IFS0<27>	IEC0<27>	IPC6<4:2>	IPC6<1:0>
SPI3RX – SPI3 Receive Done						
I2C3S – I2C3 Slave Event						
U1TX – UART1 Transmitter	28	24	IFS0<28>	IEC0<28>	IPC6<4:2>	IPC6<1:0>
SPI3TX – SPI3 Transfer Done						
I2C3M – I2C3 Master Event						
I2C1B – I2C1 Bus Collision Event	29	25	IFS0<29>	IEC0<29>	IPC6<12:10>	IPC6<9:8>
I2C1S – I2C1 Slave Event	30	25	IFS0<30>	IEC0<30>	IPC6<12:10>	IPC6<9:8>
I2C1M – I2C1 Master Event	31	25	IFS0<31>	IEC0<31>	IPC6<12:10>	IPC6<9:8>
CN – Input Change Interrupt	32	26	IFS1<0>	IEC1<0>	IPC6<20:18>	IPC6<17:16>
AD1 – ADC1 Convert Done	33	27	IFS1<1>	IEC1<1>	IPC6<28:26>	IPC6<25:24>

Note 1: Not all interrupt sources are available on all devices. See [Table 1](#), [Table 2](#) and [Table 3](#) for the list of available peripherals.

TABLE 7-1: INTERRUPT IRQ, VECTOR AND BIT LOCATION (CONTINUED)

Interrupt Source ⁽¹⁾	IRQ	Vector Number	Interrupt Bit Location			
			Flag	Enable	Priority	Sub-Priority
PMP – Parallel Master Port	34	28	IFS1<2>	IEC1<2>	IPC7<4:2>	IPC7<1:0>
CMP1 – Comparator Interrupt	35	29	IFS1<3>	IEC1<3>	IPC7<12:10>	IPC7<9:8>
CMP2 – Comparator Interrupt	36	30	IFS1<4>	IEC1<4>	IPC7<20:18>	IPC7<17:16>
U3E – UART2A Error SPI2E – SPI2 Fault I2C4B – I2C4 Bus Collision Event	37	31	IFS1<5>	IEC1<5>	IPC7<28:26>	IPC7<25:24>
U3RX – UART2A Receiver SPI2RX – SPI2 Receive Done I2C4S – I2C4 Slave Event	38	31	IFS1<6>	IEC1<6>	IPC7<28:26>	IPC7<25:24>
U3TX – UART2A Transmitter SPI2TX – SPI2 Transfer Done IC4M – I2C4 Master Event	39	31	IFS1<7>	IEC1<7>	IPC7<28:26>	IPC7<25:24>
U2E – UART3A Error SPI4E – SPI4 Fault I2C5B – I2C5 Bus Collision Event	40	32	IFS1<8>	IEC1<8>	IPC8<4:2>	IPC8<1:0>
U2RX – UART3A Receiver SPI4RX – SPI4 Receive Done I2C5S – I2C5 Slave Event	41	32	IFS1<9>	IEC1<9>	IPC8<4:2>	IPC8<1:0>
U2TX – UART3A Transmitter SPI4TX – SPI4 Transfer Done IC5M – I2C5 Master Event	42	32	IFS1<10>	IEC1<10>	IPC8<4:2>	IPC8<1:0>
I2C2B – I2C2 Bus Collision Event	43	33	IFS1<11>	IEC1<11>	IPC8<12:10>	IPC8<9:8>
I2C2S – I2C2 Slave Event	44	33	IFS1<12>	IEC1<12>	IPC8<12:10>	IPC8<9:8>
I2C2M – I2C2 Master Event	45	33	IFS1<13>	IEC1<13>	IPC8<12:10>	IPC8<9:8>
FSCM – Fail-Safe Clock Monitor	46	34	IFS1<14>	IEC1<14>	IPC8<20:18>	IPC8<17:16>
RTCC – Real-Time Clock and Calendar	47	35	IFS1<15>	IEC1<15>	IPC8<28:26>	IPC8<25:24>
DMA0 – DMA Channel 0	48	36	IFS1<16>	IEC1<16>	IPC9<4:2>	IPC9<1:0>
DMA1 – DMA Channel 1	49	37	IFS1<17>	IEC1<17>	IPC9<12:10>	IPC9<9:8>
DMA2 – DMA Channel 2	50	38	IFS1<18>	IEC1<18>	IPC9<20:18>	IPC9<17:16>
DMA3 – DMA Channel 3	51	39	IFS1<19>	IEC1<19>	IPC9<28:26>	IPC9<25:24>
DMA4 – DMA Channel 4	52	40	IFS1<20>	IEC1<20>	IPC10<4:2>	IPC10<1:0>
DMA5 – DMA Channel 5	53	41	IFS1<21>	IEC1<21>	IPC10<12:10>	IPC10<9:8>
DMA6 – DMA Channel 6	54	42	IFS1<22>	IEC1<22>	IPC10<20:18>	IPC10<17:16>
DMA7 – DMA Channel 7	55	43	IFS1<23>	IEC1<23>	IPC10<28:26>	IPC10<25:24>
FCE – Flash Control Event	56	44	IFS1<24>	IEC1<24>	IPC11<4:2>	IPC11<1:0>
USB – USB Interrupt	57	45	IFS1<25>	IEC1<25>	IPC11<12:10>	IPC11<9:8>
CAN1 – Control Area Network 1	58	46	IFS1<26>	IEC1<26>	IPC11<20:18>	IPC11<17:16>
CAN2 – Control Area Network 2	59	47	IFS1<27>	IEC1<27>	IPC11<28:26>	IPC11<25:24>
ETH – Ethernet Interrupt	60	48	IFS1<28>	IEC1<28>	IPC12<4:2>	IPC12<1:0>
IC1E – Input Capture 1 Error	61	5	IFS1<29>	IEC1<29>	IPC1<12:10>	IPC1<9:8>
IC2E – Input Capture 2 Error	62	9	IFS1<30>	IEC1<30>	IPC2<12:10>	IPC2<9:8>
IC3E – Input Capture 3 Error	63	13	IFS1<31>	IEC1<31>	IPC3<12:10>	IPC3<9:8>
IC4E – Input Capture 4 Error	64	17	IFS2<0>	IEC2<0>	IPC4<12:10>	IPC4<9:8>

Note 1: Not all interrupt sources are available on all devices. See [Table 1](#), [Table 2](#) and [Table 3](#) for the list of available peripherals.

TABLE 7-1: INTERRUPT IRQ, VECTOR AND BIT LOCATION (CONTINUED)

Interrupt Source ⁽¹⁾	IRQ	Vector Number	Interrupt Bit Location			
			Flag	Enable	Priority	Sub-Priority
IC4E – Input Capture 5 Error	65	21	IFS2<1>	IEC2<1>	IPC5<12:10>	IPC5<9:8>
PMPE – Parallel Master Port Error	66	28	IFS2<2>	IEC2<2>	IPC7<4:2>	IPC7<1:0>
U4E – UART4 Error	67	49	IFS2<3>	IEC2<3>	IPC12<12:10>	IPC12<9:8>
U4RX – UART4 Receiver	68	49	IFS2<4>	IEC2<4>	IPC12<12:10>	IPC12<9:8>
U4TX – UART4 Transmitter	69	49	IFS2<5>	IEC2<5>	IPC12<12:10>	IPC12<9:8>
U6E – UART6 Error	70	50	IFS2<6>	IEC2<6>	IPC12<20:18>	IPC12<17:16>
U6RX – UART6 Receiver	71	50	IFS2<7>	IEC2<7>	IPC12<20:18>	IPC12<17:16>
U6TX – UART6 Transmitter	72	50	IFS2<8>	IEC2<8>	IPC12<20:18>	IPC12<17:16>
U5E – UART5 Error	73	51	IFS2<9>	IEC2<9>	IPC12<28:26>	IPC12<25:24>
U5RX – UART5 Receiver	74	51	IFS2<10>	IEC2<10>	IPC12<28:26>	IPC12<25:24>
U5TX – UART5 Transmitter	75	51	IFS2<11>	IEC2<11>	IPC12<28:26>	IPC12<25:24>
(Reserved)	—	—	—	—	—	—
Lowest Natural Order Priority						

Note 1: Not all interrupt sources are available on all devices. See [Table 1](#), [Table 2](#) and [Table 3](#) for the list of available peripherals.

8.0 OSCILLATOR CONFIGURATION

Note 1: This data sheet summarizes the features of the PIC32MX5XX/6XX/7XX family of devices. It is not intended to be a comprehensive reference source. To complement the information in this data sheet, refer to **Section 6. "Oscillator"** (DS61112) in the "PIC32 Family Reference Manual", which is available from the Microchip web site (www.microchip.com/PIC32).

2: Some registers and associated bits described in this section may not be available on all devices. Refer to **Section 4.0 "Memory Organization"** in this data sheet for device-specific register and bit information.

The PIC32MX5XX/6XX/7XX oscillator system has the following modules and features:

- A total of four external and internal oscillator options as clock sources
- On-Chip PLL with user-selectable input divider, multiplier and output divider to boost operating frequency on select internal and external oscillator sources
- On-Chip user-selectable divisor postscaler on select oscillator sources
- Software-controllable switching between various clock sources
- A Fail-Safe Clock Monitor (FSCM) that detects clock failure and permits safe application recovery or shutdown
- Dedicated On-Chip PLL for USB peripheral

Figure 8-1 shows the Oscillator module block diagram.

FIGURE 8-1: PIC32MX5XX/6XX/7XX FAMILY OSCILLATOR BLOCK DIAGRAM

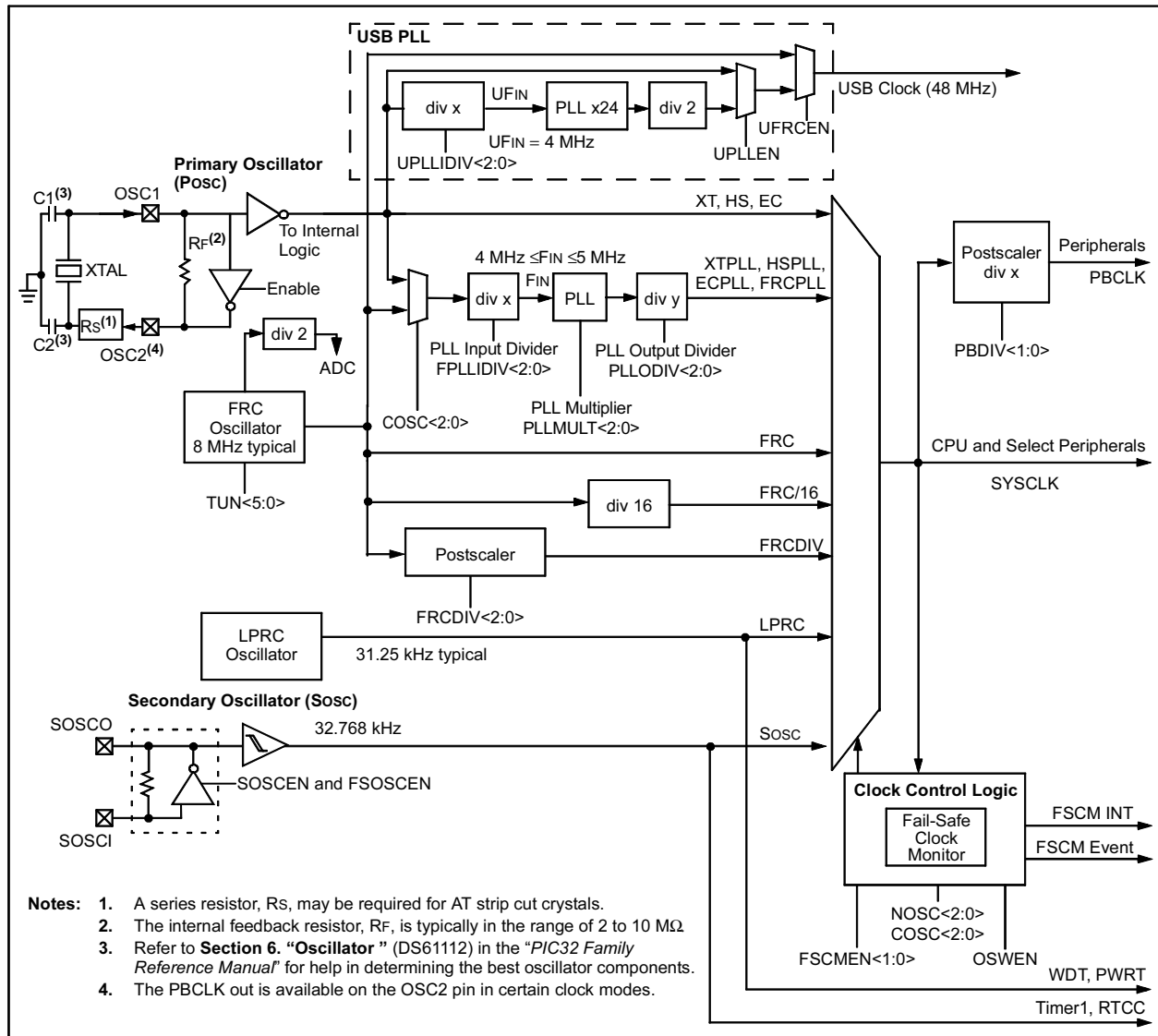

NOTES:

9.0 PREFETCH CACHE

Note 1: This data sheet summarizes the features of the PIC32MX5XX/6XX/7XX family of devices. It is not intended to be a comprehensive reference source. To complement the information in this data sheet, refer to **Section 4. “Prefetch Cache”** (DS61119) in the *“PIC32 Family Reference Manual”*, which is available from the Microchip web site (www.microchip.com/PIC32).

2: Some registers and associated bits described in this section may not be available on all devices. Refer to **Section 4.0 “Memory Organization”** in this data sheet for device-specific register and bit information.

Prefetch cache increases performance for applications executing out of the cacheable program Flash memory regions by implementing instruction caching, constant data caching and instruction prefetching.

9.1 Features

- 16 fully associative lockable cache lines
- 16-byte cache lines
- Up to four cache lines allocated to data
- Two cache lines with address mask to hold repeated instructions
- Pseudo LRU replacement policy
- All cache lines are software writable
- 16-byte parallel memory fetch
- Predictive instruction prefetch

A simplified block diagram of the Prefetch Cache module is illustrated in [Figure 9-1](#).

FIGURE 9-1: PREFETCH CACHE MODULE BLOCK DIAGRAM

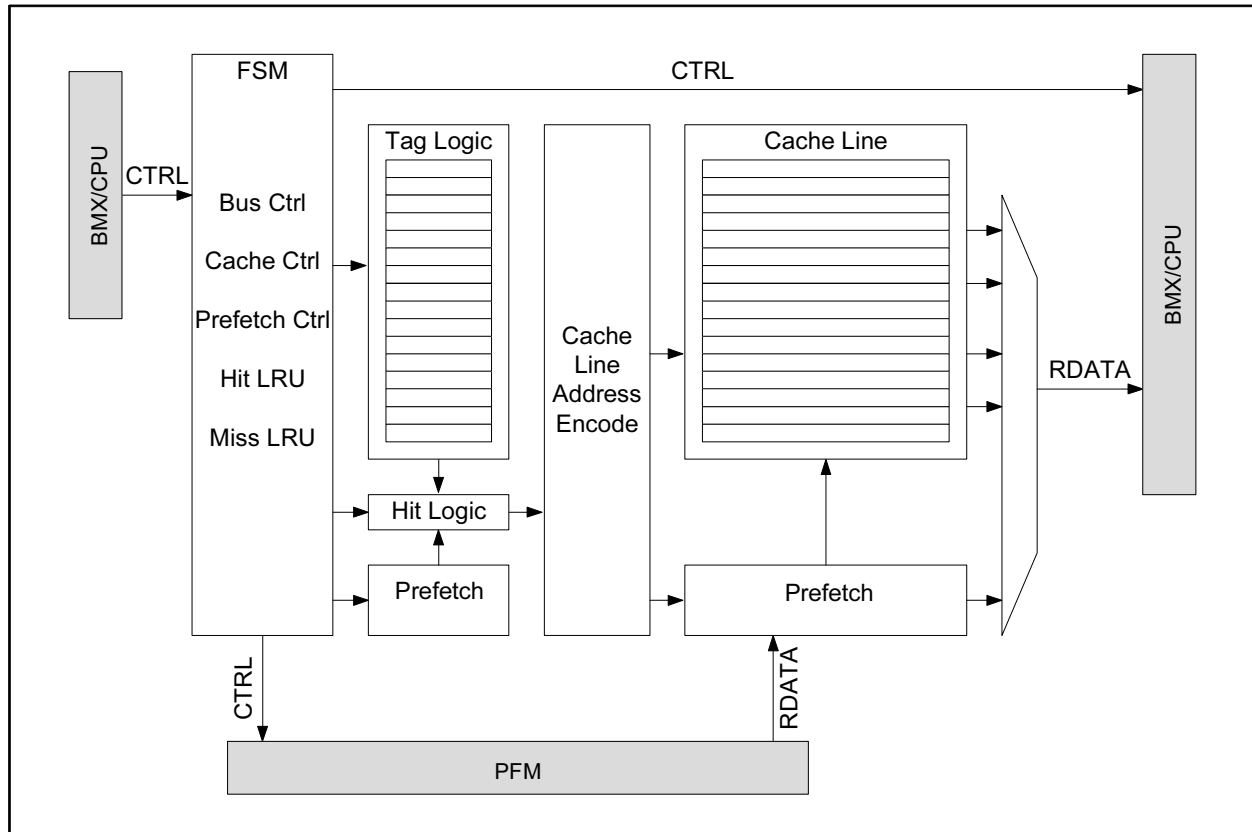

NOTES:

10.0 DIRECT MEMORY ACCESS (DMA) CONTROLLER

Note 1: This data sheet summarizes the features of the PIC32MX5XX/6XX/7XX family of devices. It is not intended to be a comprehensive reference source. To complement the information in this data sheet, refer to **Section 31. “Direct Memory Access (DMA) Controller”** (DS61117) in the “PIC32 Family Reference Manual”, which is available from the Microchip web site (www.microchip.com/PIC32).

2: Some registers and associated bits described in this section may not be available on all devices. Refer to **Section 4.0 “Memory Organization”** in this data sheet for device-specific register and bit information.

The PIC32 Direct Memory Access (DMA) controller is a bus master module useful for data transfers between different devices without CPU intervention. The source and destination of a DMA transfer can be any of the memory mapped modules existent in the PIC32 (such as Peripheral Bus (PBUS) devices: SPI, UART, PMP, etc.) or memory itself.

Following are some of the key features of the DMA controller module:

- Four identical channels, each featuring:
 - Auto-increment source and destination address registers
 - Source and destination pointers
 - Memory to memory and memory to peripheral transfers
- Automatic word-size detection:
 - Transfer granularity, down to byte level
 - Bytes need not be word-aligned at source and destination
- Fixed priority channel arbitration
- Flexible DMA channel operating modes:
 - Manual (software) or automatic (interrupt) DMA requests
 - One-Shot or Auto-Repeat Block Transfer modes
 - Channel-to-channel chaining
- Flexible DMA requests:
 - A DMA request can be selected from any of the peripheral interrupt sources
 - Each channel can select any (appropriate) observable interrupt as its DMA request source
 - A DMA transfer abort can be selected from any of the peripheral interrupt sources
 - Pattern (data) match transfer termination
- Multiple DMA channel status interrupts:
 - DMA channel block transfer complete
 - Source empty or half empty
 - Destination full or half full
 - DMA transfer aborted due to an external event
 - Invalid DMA address generated
- DMA debug support features:
 - Most recent address accessed by a DMA channel
 - Most recent DMA channel to transfer data
- CRC Generation module:
 - CRC module can be assigned to any of the available channels
 - CRC module is highly configurable

FIGURE 10-1: DMA BLOCK DIAGRAM

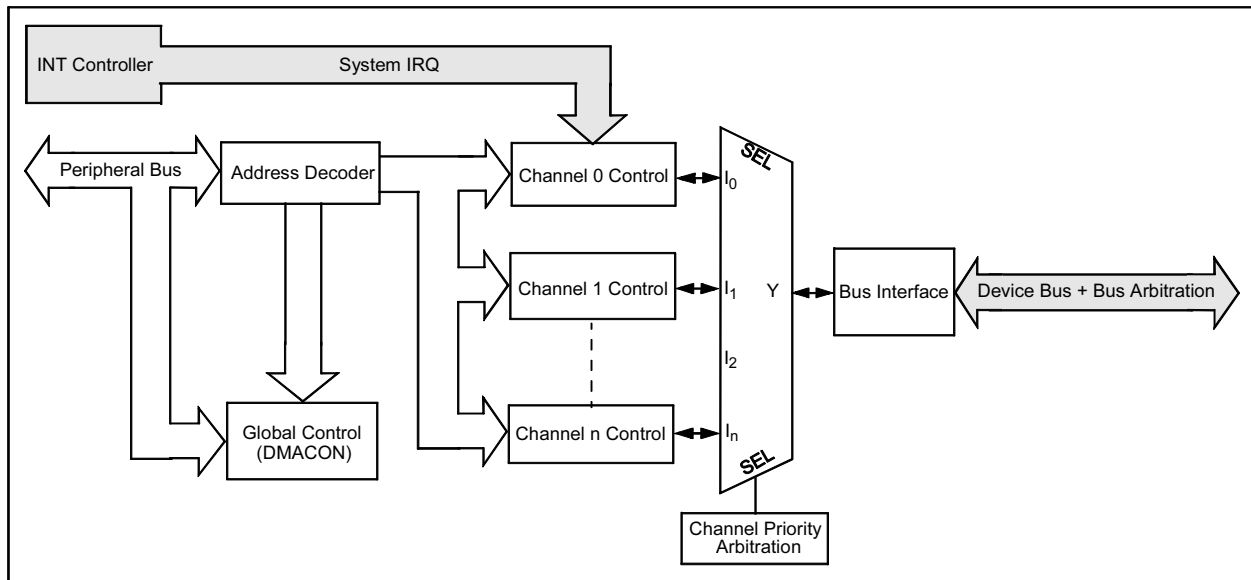

NOTES:

11.0 USB ON-THE-GO (OTG)

Note 1: This data sheet summarizes the features of the PIC32MX5XX/6XX/7XX family of devices. It is not intended to be a comprehensive reference source. To complement the information in this data sheet, refer to **Section 27. “USB On-The-Go (OTG)”** (DS61126) in the “*PIC32 Family Reference Manual*”, which is available from the Microchip web site (www.microchip.com/PIC32).

2: Some registers and associated bits described in this section may not be available on all devices. Refer to **Section 4.0 “Memory Organization”** in this data sheet for device-specific register and bit information.

The Universal Serial Bus (USB) module contains analog and digital components to provide a USB 2.0 full-speed and low-speed embedded host, full-speed device or OTG implementation with a minimum of external components. This module in Host mode is intended for use as an embedded host and therefore does not implement a UHCI or OHCI controller.

The USB module consists of the clock generator, the USB voltage comparators, the transceiver, the Serial Interface Engine (SIE), a dedicated USB DMA controller, pull-up and pull-down resistors, and the register interface. A block diagram of the PIC32 USB OTG module is presented in [Figure 11-1](#).

The clock generator provides the 48 MHz clock required for USB full-speed and low-speed communication. The voltage comparators monitor the voltage on the VBUS pin to determine the state of the bus. The transceiver provides the analog translation between the USB bus and the digital logic. The SIE is a state machine that transfers data to and from the endpoint buffers and generates the hardware protocol for data transfers. The USB DMA controller transfers data between the data buffers in RAM and the SIE. The integrated pull-up and pull-down resistors eliminate the need for external signaling components. The register interface allows the CPU to configure and communicate with the module.

The PIC32 USB module includes the following features:

- USB Full-speed support for host and device
- Low-speed host support
- USB OTG support
- Integrated signaling resistors
- Integrated analog comparators for VBUS monitoring
- Integrated USB transceiver
- Transaction handshaking performed by hardware
- Endpoint buffering anywhere in system RAM
- Integrated DMA to access system RAM and Flash

Note: The implementation and use of the USB specifications, as well as other third party specifications or technologies, may require licensing; including, but not limited to, USB Implementers Forum, Inc. (also referred to as USB-IF). The user is fully responsible for investigating and satisfying any applicable licensing obligations.

FIGURE 11-1: PIC32MX5XX/6XX/7XX FAMILY USB INTERFACE DIAGRAM

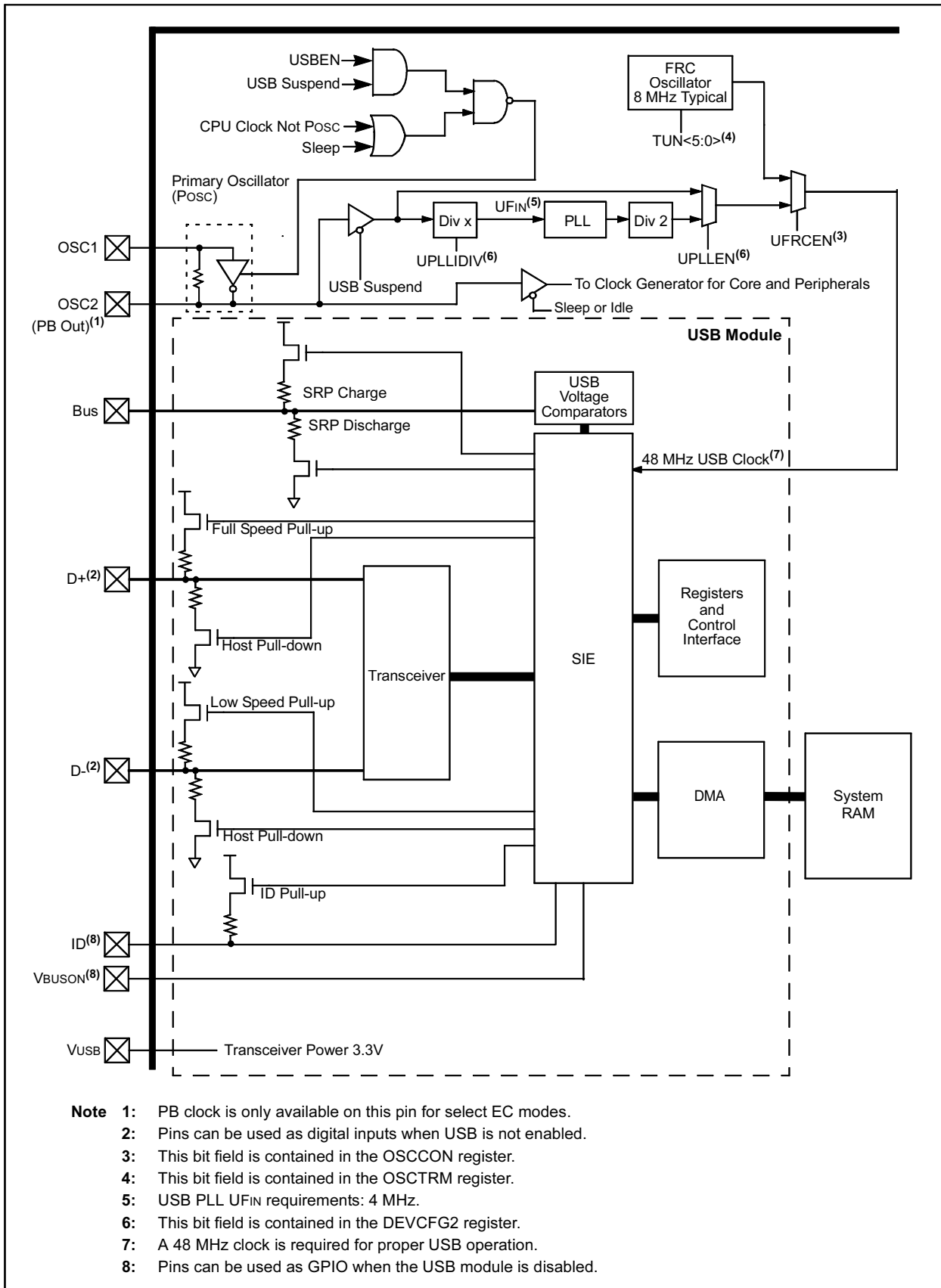

12.0 I/O PORTS

Note 1: This data sheet summarizes the features of the PIC32MX5XX/6XX/7XX family of devices. It is not intended to be a comprehensive reference source. To complement the information in this data sheet, refer to **Section 12. "I/O Ports"** (DS61120) in the *"PIC32 Family Reference Manual"*, which is available from the Microchip web site (www.microchip.com/PIC32).

2: Some registers and associated bits described in this section may not be available on all devices. Refer to **Section 4.0 "Memory Organization"** in this data sheet for device-specific register and bit information.

General purpose I/O pins are the simplest of peripherals. They allow the PIC® MCU to monitor and control other devices. To add flexibility and functionality, some pins are multiplexed with alternate function(s). These functions depend on which peripheral features are on the device. In general, when a peripheral is functioning, that pin may not be used as a general purpose I/O pin.

Following are some of the key features of this module:

- Individual output pin open-drain enable/disable
- Individual input pin weak pull-up enable/disable
- Monitor selective inputs and generate interrupt when change in pin state is detected
- Operation during CPU Sleep and Idle modes
- Fast bit manipulation using CLR, SET and INV registers

Figure 12-1 illustrates a block diagram of a typical multiplexed I/O port.

FIGURE 12-1: BLOCK DIAGRAM OF A TYPICAL MULTIPLEXED PORT STRUCTURE

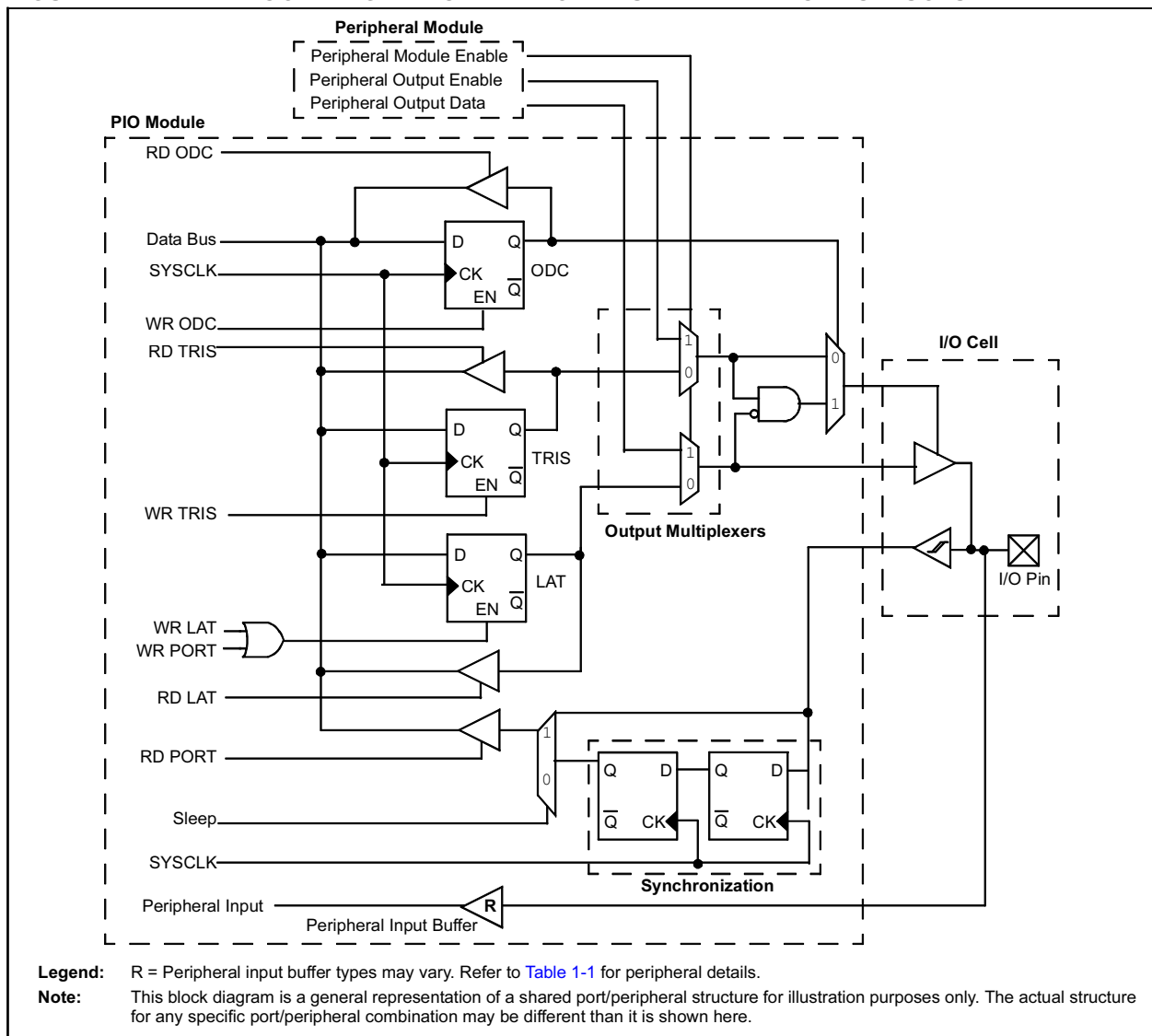

12.1 Parallel I/O (PIO) Ports

All port pins have three registers (TRIS, LAT and PORT) that are directly associated with their operation.

TRIS is a Data Direction or Tri-State Control register that determines whether a digital pin is an input or an output. Setting a TRISx register bit = 1, configures the corresponding I/O pin as an input; setting a TRISx register bit = 0, configures the corresponding I/O pin as an output. All port I/O pins are defined as inputs after a device Reset. Certain I/O pins are shared with analog peripherals and default to analog inputs after a device Reset.

PORT is a register used to read the current state of the signal applied to the port I/O pins. Writing to a PORTx register performs a write to the port's latch, LATx register, latching the data to the port's I/O pins.

LAT is a register used to write data to the port I/O pins. The LATx Latch register holds the data written to either the LATx or PORTx registers. Reading the LATx Latch register reads the last value written to the corresponding PORT or Latch register.

Not all port I/O pins are implemented on some devices, therefore, the corresponding PORTx, LATx and TRISx register bits will read as zeros.

12.1.1 CLR, SET AND INV REGISTERS

Every I/O module register has a corresponding CLR (clear), SET (set) and INV (invert) register designed to provide fast atomic bit manipulations. As the name of the register implies, a value written to a SET, CLR or INV register effectively performs the implied operation, but only on the corresponding base register and only bits specified as '1' are modified. Bits specified as '0' are not modified.

Reading SET, CLR and INV registers returns undefined values. To see the affects of a write operation to a SET, CLR or INV register, the base register must be read.

Note: Using a PORTxINV register to toggle a bit is recommended because the operation is performed in hardware atomically, using fewer instructions, as compared to the traditional read-modify-write method shown below:

```
PORTC ^= 0x0001;
```

12.1.2 DIGITAL INPUTS

Pins are configured as digital inputs by setting the corresponding TRIS register bits = 1. When configured as inputs, they are either TTL buffers or Schmitt Triggers. Several digital pins share functionality with analog inputs and default to the analog inputs at POR. Setting the corresponding bit in the AD1PCFG register = 1 enables the pin as a digital pin.

The maximum input voltage allowed on the input pins is the same as the maximum V_{IH} specification. Refer to [Section 31.0 "Electrical Characteristics"](#) for V_{IH} specification details.

Note: Analog levels on any pin that is defined as a digital input (including the ANx pins) may cause the input buffer to consume current that exceeds the device specifications.

12.1.3 ANALOG INPUTS

Certain pins can be configured as analog inputs used by the ADC and comparator modules. Setting the corresponding bits in the AD1PCFG register = 0 enables the pin as an analog input pin and must have the corresponding TRIS bit set = 1 (input). If the TRIS bit is cleared = 0 (output), the digital output level (V_{OH} or V_{OL}) will be converted. Any time a port I/O pin is configured as analog, its digital input is disabled and the corresponding PORTx register bit will read '0'. The AD1PCFG register has a default value of 0x0000; therefore, all pins that share ANx functions are analog (not digital) by default.

12.1.4 DIGITAL OUTPUTS

Pins are configured as digital outputs by setting the corresponding TRIS register bits = 0. When configured as digital outputs, these pins are CMOS drivers or can be configured as open-drain outputs by setting the corresponding bits in the Open-Drain Configuration (ODCx) register.

The open-drain feature allows generation of outputs higher than V_{DD} (e.g., 5V) on any desired 5V tolerant pins by using external pull-up resistors. The maximum open-drain voltage allowed is the same as the maximum V_{IH} specification.

See the ["Pin Diagrams"](#) section for the available pins and their functionality.

12.1.5 ANALOG OUTPUTS

Certain pins can be configured as analog outputs, such as the CV_{REF} output voltage used by the comparator module. Configuring the comparator reference module to provide this output will present the analog output voltage on the pin, independent of the TRIS register setting for the corresponding pin.

12.1.6 INPUT CHANGE NOTIFICATION

The input change notification function of the I/O ports (CNx) allows devices to generate interrupt requests in response to change-of-state on selected pin.

Each CNx pin also has a weak pull-up, which acts as a current source connected to the pin. The pull-ups are enabled by setting the corresponding bit in the CNPUE register.

NOTES:

14.0 TIMER2/3, TIMER4/5

Note 1: This data sheet summarizes the features of the PIC32MX5XX/6XX/7XX family of devices. It is not intended to be a comprehensive reference source. To complement the information in this data sheet, refer to **Section 14. “Timers”** (DS61105) of the *“PIC32 Family Reference Manual”*, which is available from the Microchip web site (www.microchip.com/PIC32).

2: Some registers and associated bits described in this section may not be available on all devices. Refer to **Section 4.0 “Memory Organization”** in this data sheet for device-specific register and bit information.

This family of PIC32 devices features four synchronous 16-bit timers (default) that can operate as a free-running interval timer for various timing applications and counting external events. The following modes are supported:

- Synchronous internal 16-bit timer
- Synchronous internal 16-bit gated timer
- Synchronous external 16-bit timer

Two 32-bit synchronous timers are available by combining Timer2 with Timer3 and Timer4 with Timer5. The 32-bit timers can operate in three modes:

- Synchronous internal 32-bit timer
- Synchronous internal 32-bit gated timer
- Synchronous external 32-bit timer

Note: In this chapter, references to registers, TxCON, TMRx and PRx, use ‘x’ to represent Timer2 through 5 in 16-bit modes. In 32-bit modes, ‘x’ represents Timer2 or 4; ‘y’ represents Timer3 or 5.

14.1 Additional Supported Features

- Selectable clock prescaler
- Timers operational during CPU idle
- Time base for Input Capture and Output Compare modules (Timer2 and Timer3 only)
- ADC event trigger (Timer3 only)
- Fast bit manipulation using CLR, SET and INV registers

FIGURE 14-1: TIMER2/3, 4/5 BLOCK DIAGRAM (16-BIT)

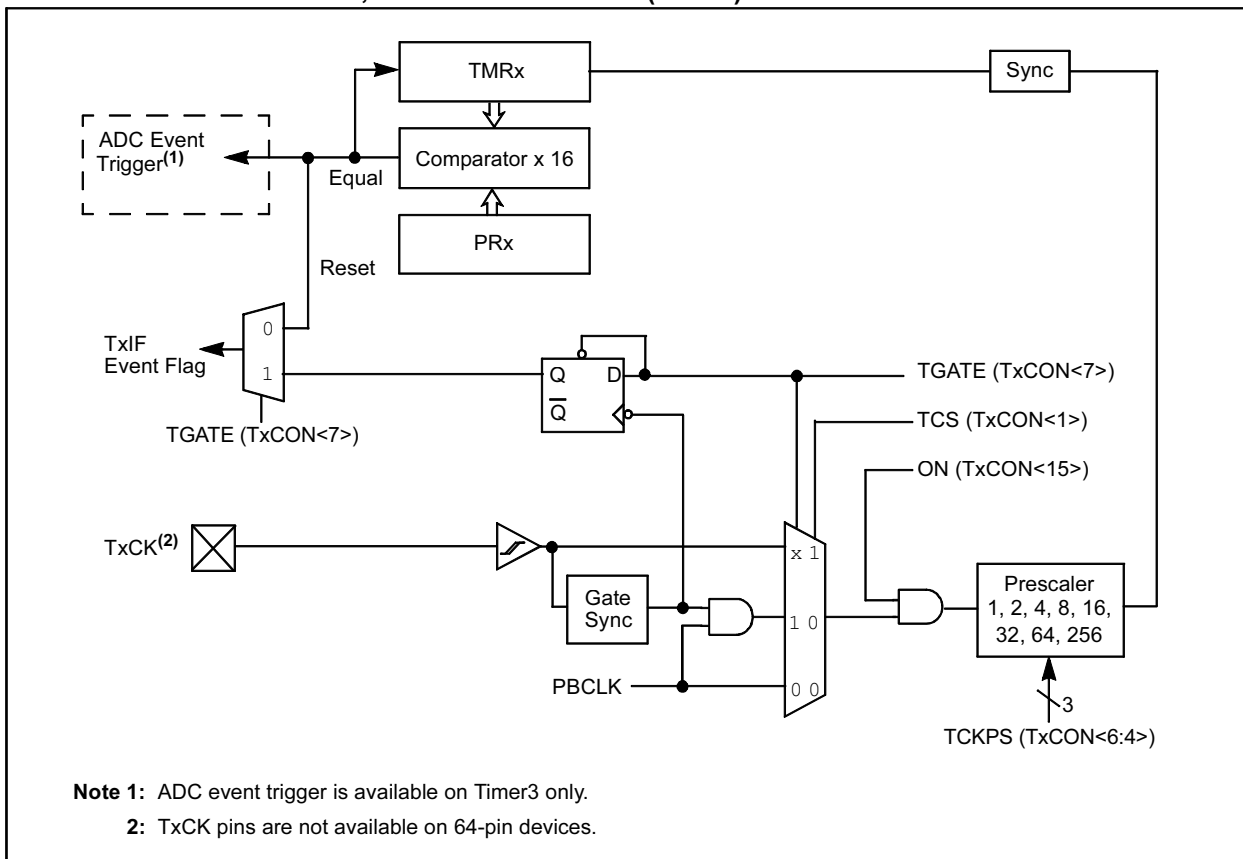
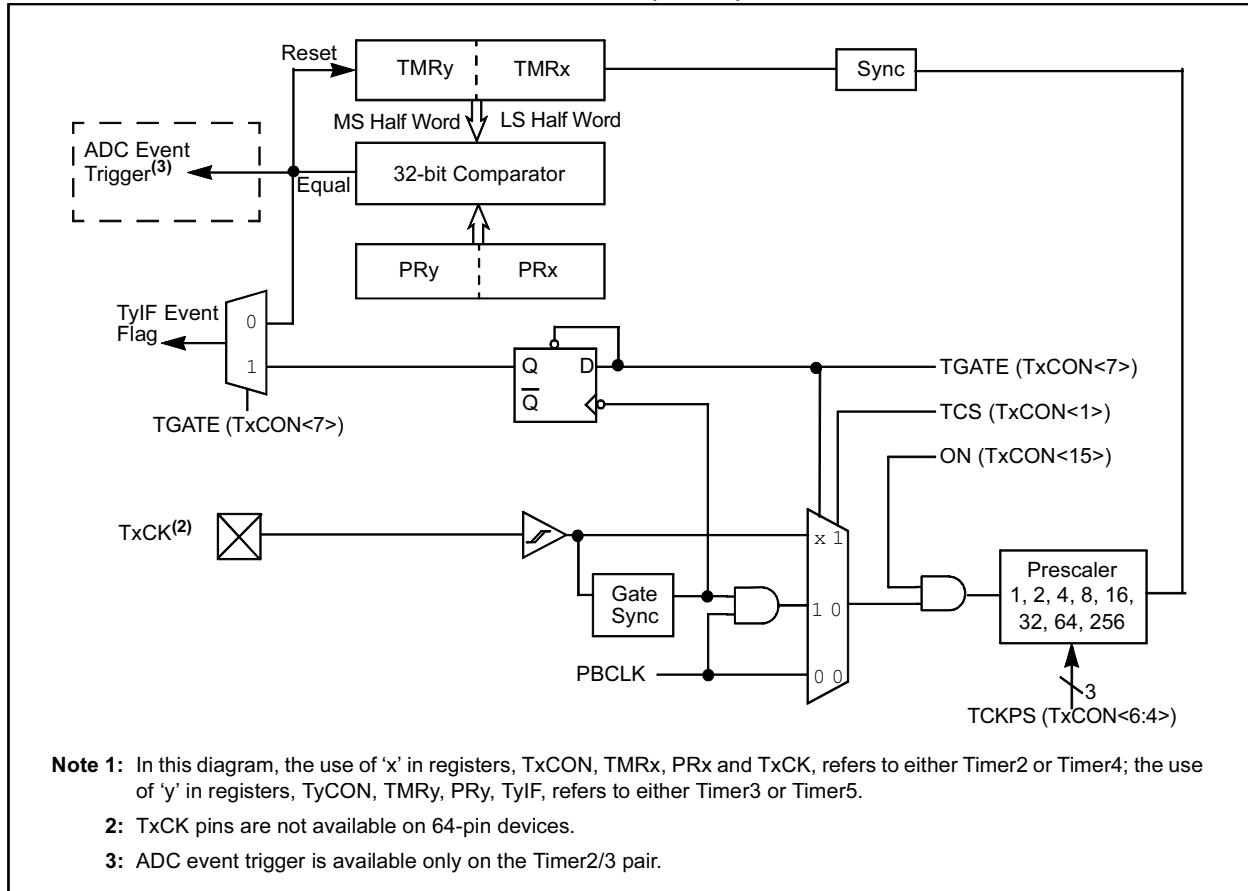

FIGURE 14-2: TIMER2/3, 4/5 BLOCK DIAGRAM (32-BIT)⁽¹⁾



15.0 INPUT CAPTURE

Note 1: This data sheet summarizes the features of the PIC32MX5XX/6XX/7XX family of devices. It is not intended to be a comprehensive reference source. To complement the information in this data sheet, refer to **Section 15. “Input Capture”** (DS61122) of the “PIC32 Family Reference Manual”, which is available from the Microchip web site (www.microchip.com/PIC32).

2: Some registers and associated bits described in this section may not be available on all devices. Refer to **Section 4.0 “Memory Organization”** in this data sheet for device-specific register and bit information.

The Input Capture module is useful in applications requiring frequency (period) and pulse measurement.

The Input Capture module captures the 16-bit or 32-bit value of the selected Time Base registers when an event occurs at the ICx pin. The following events cause capture events:

1. Simple capture event modes
 - Capture timer value on every falling edge of input at ICx pin
 - Capture timer value on every rising edge of input at ICx pin
2. Capture timer value on every edge (rising and falling)
3. Capture timer value on every edge (rising and falling), specified edge first.
4. Prescaler capture event modes
 - Capture timer value on every 4th rising edge of input at ICx pin
 - Capture timer value on every 16th rising edge of input at ICx pin

Each input capture channel can select between one of two 16-bit timers (Timer2 or Timer3) for the time base, or two 16-bit timers (Timer2 and Timer3) together to form a 32-bit timer. The selected timer can use either an internal or external clock.

Other operational features include:

- Device wake-up from capture pin during CPU Sleep and Idle modes
- Interrupt on input capture event
- 4-word FIFO buffer for capture values
Interrupt optionally generated after 1, 2, 3 or 4 buffer locations are filled
- Input capture can also be used to provide additional sources of external interrupts

FIGURE 15-1: INPUT CAPTURE BLOCK DIAGRAM

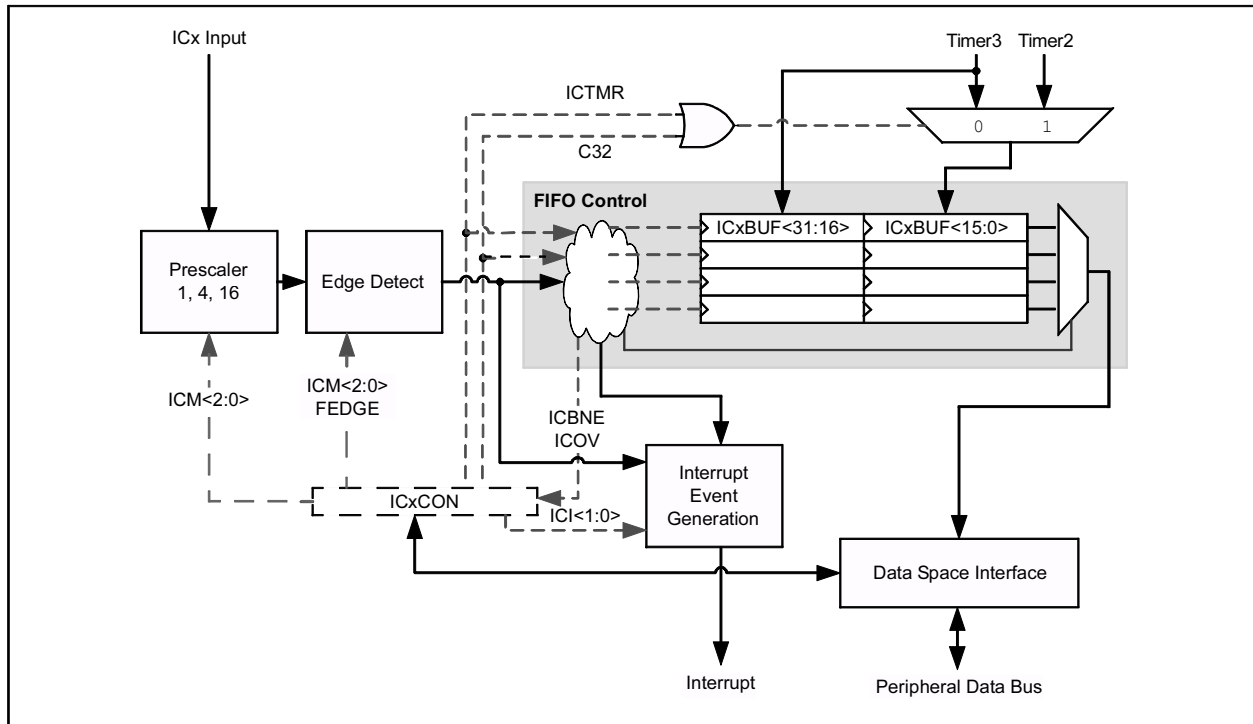

NOTES:

16.0 OUTPUT COMPARE

Note 1: This data sheet summarizes the features of the PIC32MX5XX/6XX/7XX family of devices. It is not intended to be a comprehensive reference source. To complement the information in this data sheet, refer to **Section 16. “Output Compare”** (DS61111) in the *“PIC32 Family Reference Manual”*, which is available from the Microchip web site (www.microchip.com/PIC32).

2: Some registers and associated bits described in this section may not be available on all devices. Refer to **Section 4.0 “Memory Organization”** in this data sheet for device-specific register and bit information.

The Output Compare module (OCMP) is used to generate a single pulse or a train of pulses in response to selected time base events. For all modes of operation, the OCMP module compares the values stored in the OCxR and/or the OCxRS registers to the value in the selected timer. When a match occurs, the OCMP module generates an event based on the selected mode of operation.

The following are some of the key features:

- Multiple Output Compare Modules in a device
- Programmable interrupt generation on compare event
- Single and Dual Compare modes
- Single and continuous output pulse generation
- Pulse-Width Modulation (PWM) mode
- Hardware-based PWM Fault detection and automatic output disable
- Programmable selection of 16-bit or 32-bit time bases
- Can operate from either of two available 16-bit time bases or a single 32-bit time base

FIGURE 16-1: OUTPUT COMPARE MODULE BLOCK DIAGRAM

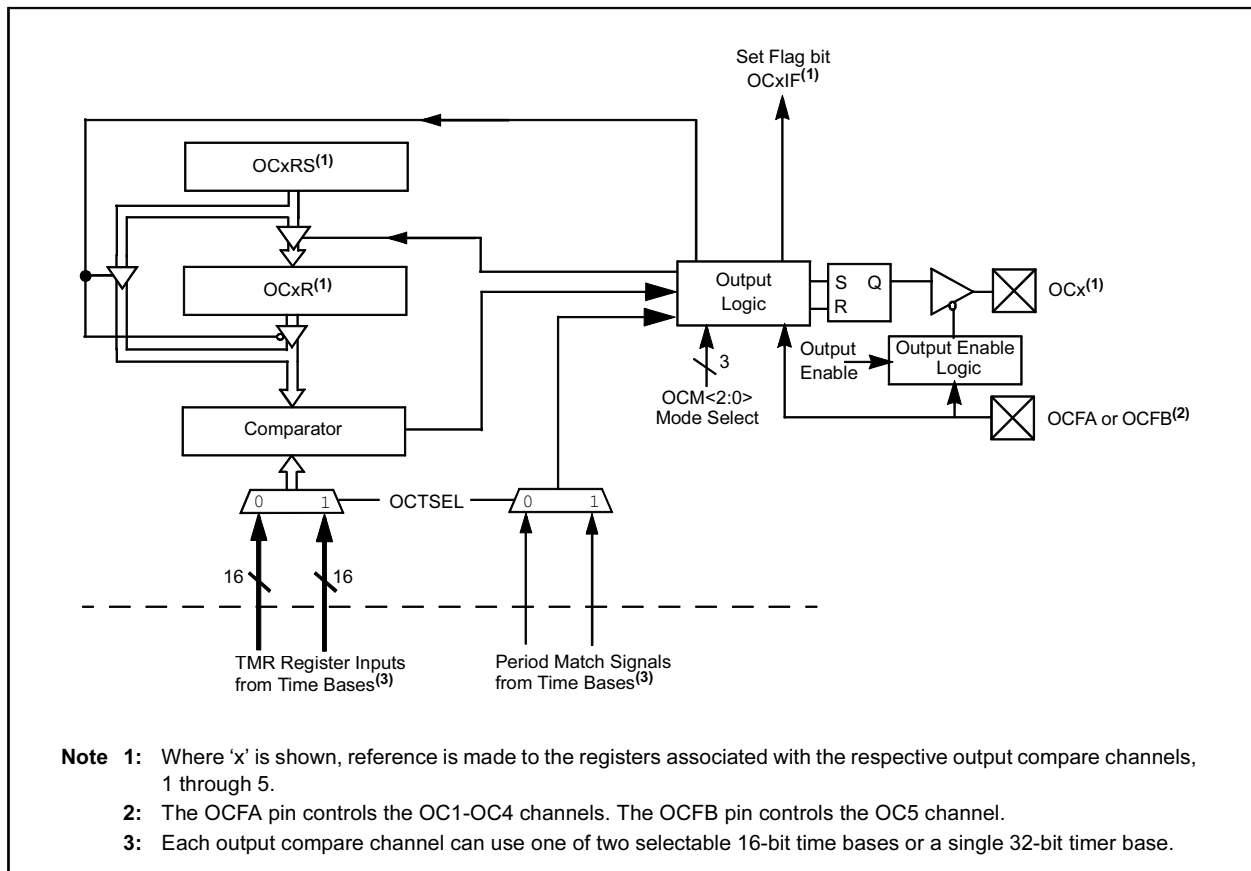

NOTES:

17.0 SERIAL PERIPHERAL INTERFACE (SPI)

Note 1: This data sheet summarizes the features of the PIC32MX5XX/6XX/7XX family of devices. It is not intended to be a comprehensive reference source. To complement the information in this data sheet, refer to **Section 23. “Serial Peripheral Interface (SPI)”** (DS61106) in the “PIC32 Family Reference Manual”, which is available from the Microchip web site (www.microchip.com/PIC32).

2: Some registers and associated bits described in this section may not be available on all devices. Refer to **Section 4.0 “Memory Organization”** in this data sheet for device-specific register and bit information.

The SPI module is a synchronous serial interface that is useful for communicating with external peripherals and other microcontroller devices. These peripheral devices may be Serial EEPROMs, Shift registers, display drivers, Analog-to-Digital Converters, etc. The PIC32 SPI module is compatible with Motorola® SPI and SIOF interfaces.

Following are some of the key features of this module:

- Master and Slave modes support
- Four different clock formats
- Enhanced Framed SPI protocol support
- User-configurable 8-bit, 16-bit and 32-bit data width
- Separate SPI FIFO buffers for receive and transmit
 - FIFO buffers act as 4/8/16-level deep FIFOs based on 32/16/8-bit data width
- Programmable interrupt event on every 8-bit, 16-bit and 32-bit data transfer
- Operation during CPU Sleep and Idle mode
- Fast bit manipulation using CLR, SET and INV registers

FIGURE 17-1: SPI MODULE BLOCK DIAGRAM

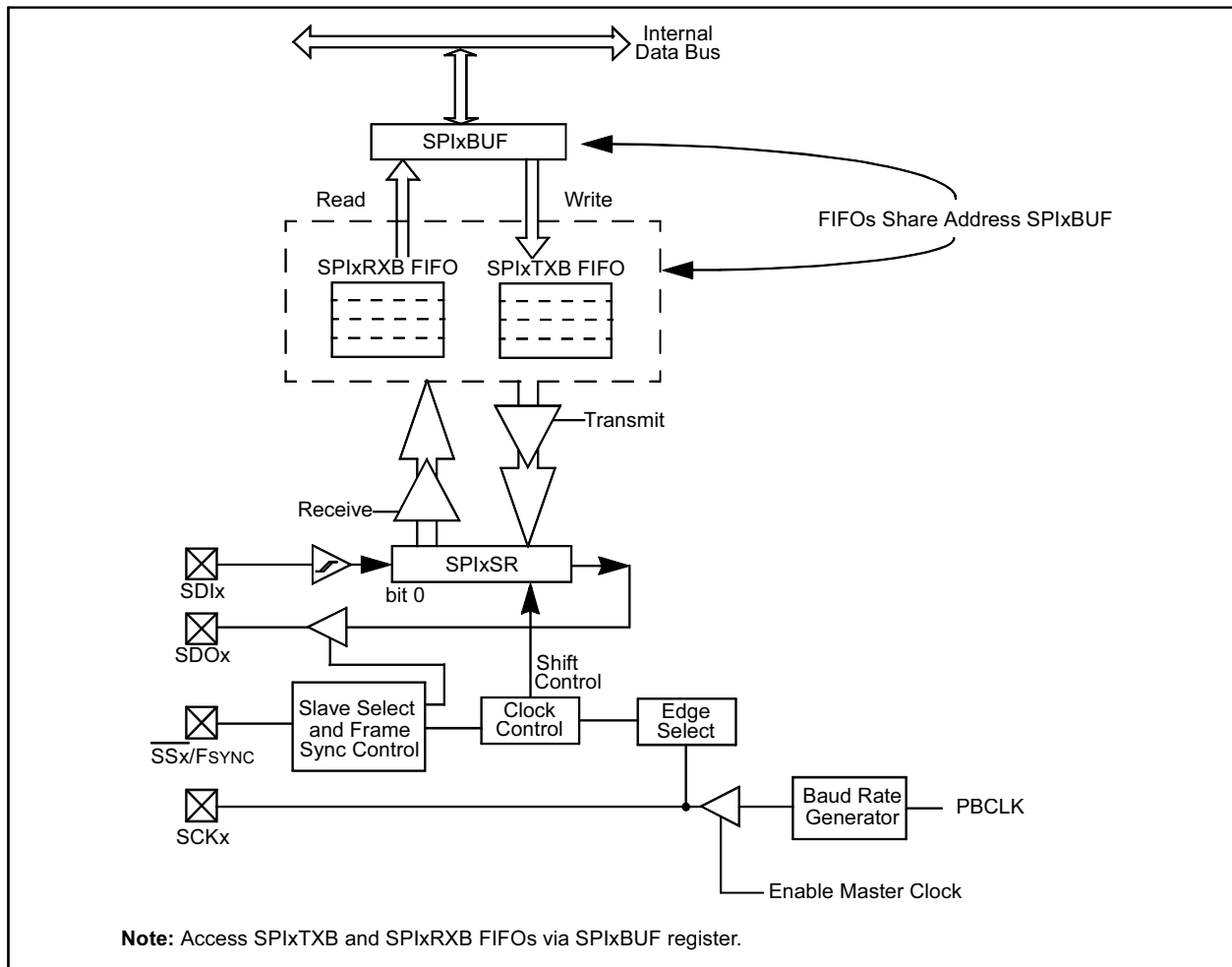

NOTES:

18.0 INTER-INTEGRATED CIRCUIT™ (I²C™)

Note 1: This data sheet summarizes the features of the PIC32MX5XX/6XX/7XX family of devices. It is not intended to be a comprehensive reference source. To complement the information in this data sheet, refer to **Section 24. “Inter-Integrated Circuit™ (I²C™)”** (DS61116) in the “PIC32 Family Reference Manual”, which is available from the Microchip web site (www.microchip.com/PIC32).

2: Some registers and associated bits described in this section may not be available on all devices. Refer to **Section 4.0 “Memory Organization”** in this data sheet for device-specific register and bit information.

The I²C module provides complete hardware support for both Slave and Multi-Master modes of the I²C serial communication standard. [Figure 18-1](#) illustrates the I²C module block diagram.

Each I²C module has a 2-pin interface: the SCLx pin is clock and the SDAx pin is data.

Each I²C module offers the following key features:

- I²C interface supporting both master and slave operation
- I²C Slave mode supports 7-bit and 10-bit addressing
- I²C Master mode supports 7-bit and 10-bit addressing
- I²C port allows bidirectional transfers between master and slaves
- Serial clock synchronization for the I²C port can be used as a handshake mechanism to suspend and resume serial transfer (SCLREL control)
- I²C supports multi-master operation; detects bus collision and arbitrates accordingly
- Provides support for address bit masking

FIGURE 18-1: I²C™ BLOCK DIAGRAM

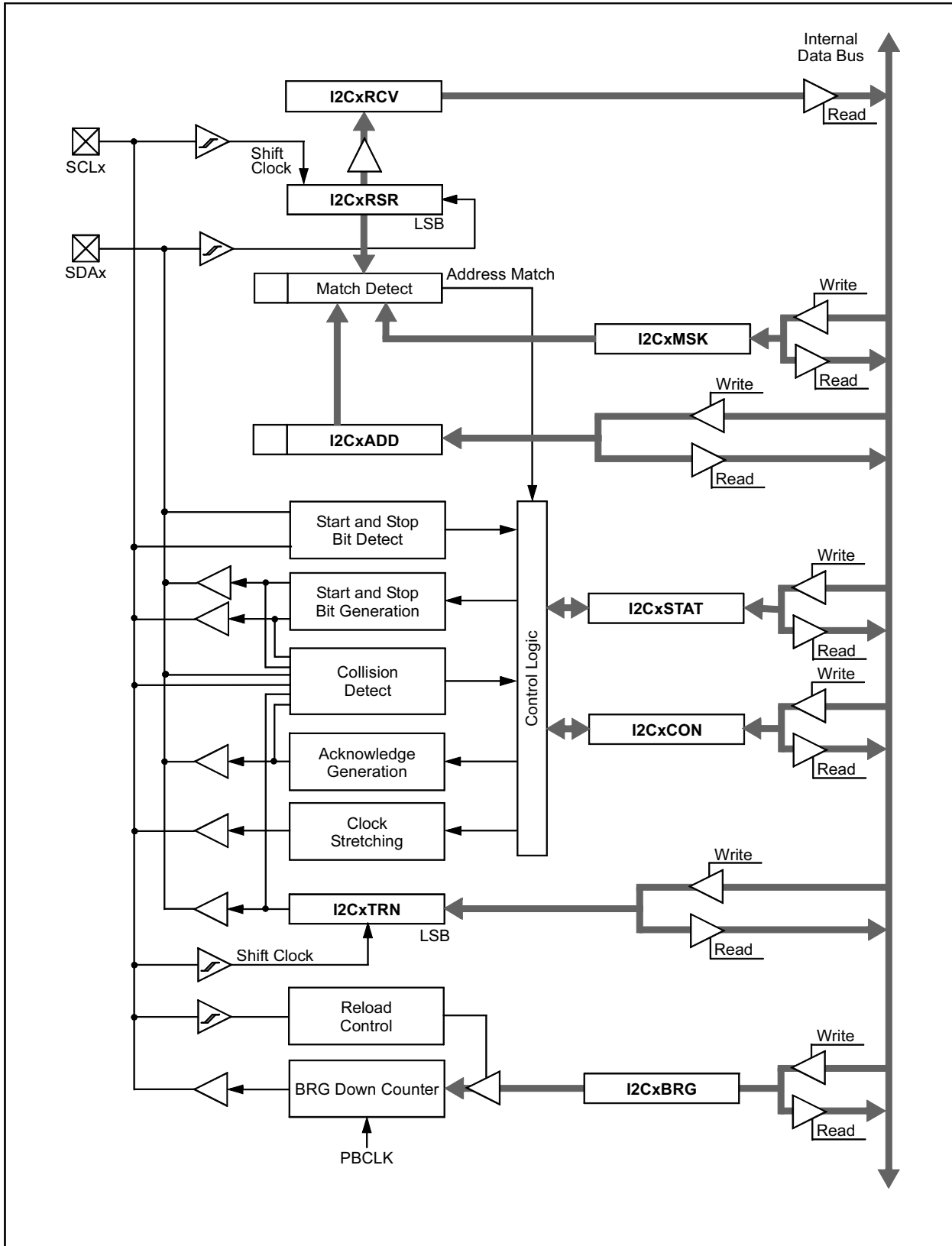

19.0 UNIVERSAL ASYNCHRONOUS RECEIVER TRANSMITTER (UART)

Note 1: This data sheet summarizes the features of the PIC32MX5XX/6XX/7XX family of devices. It is not intended to be a comprehensive reference source. To complement the information in this data sheet, refer to **Section 21. “Universal Asynchronous Receiver Transmitter (UART)”** (DS61107) in the “PIC32 Family Reference Manual”, which is available from the Microchip web site (www.microchip.com/PIC32).

2: Some registers and associated bits described in this section may not be available on all devices. Refer to **Section 4.0 “Memory Organization”** in this data sheet for device-specific register and bit information.

The UART module is one of the serial I/O modules available in PIC32MX5XX/6XX/7XX family devices. The UART is a full-duplex, asynchronous communication channel that communicates with peripheral devices and personal computers through protocols, such as RS-232, RS-485, LIN 1.2 and IrDA®. The module also supports the hardware flow control option, with \overline{UxCTS} and \overline{UxRTS} pins, and also includes an IrDA encoder and decoder.

The primary features of the UART module are:

- Full-duplex, 8-bit or 9-bit data transmission
- Even, Odd or No Parity options (for 8-bit data)
- One or two Stop bits
- Hardware auto-baud feature
- Hardware flow control option
- Fully integrated Baud Rate Generator (BRG) with 16-bit prescaler
- Baud rates ranging from 76 bps to 20 Mbps at 80 MHz
- 8-level deep First-In-First-Out (FIFO) transmit data buffer
- 8-level deep FIFO receive data buffer
- Parity, framing and buffer overrun error detection
- Support for interrupt-only on address detect (9th bit = 1)
- Separate transmit and receive interrupts
- Loopback mode for diagnostic support
- LIN 1.2 Protocol support
- IrDA encoder and decoder with 16x baud clock output for external IrDA encoder/decoder support

Figure 19-1 illustrates a simplified block diagram of the UART.

FIGURE 19-1: UART SIMPLIFIED BLOCK DIAGRAM

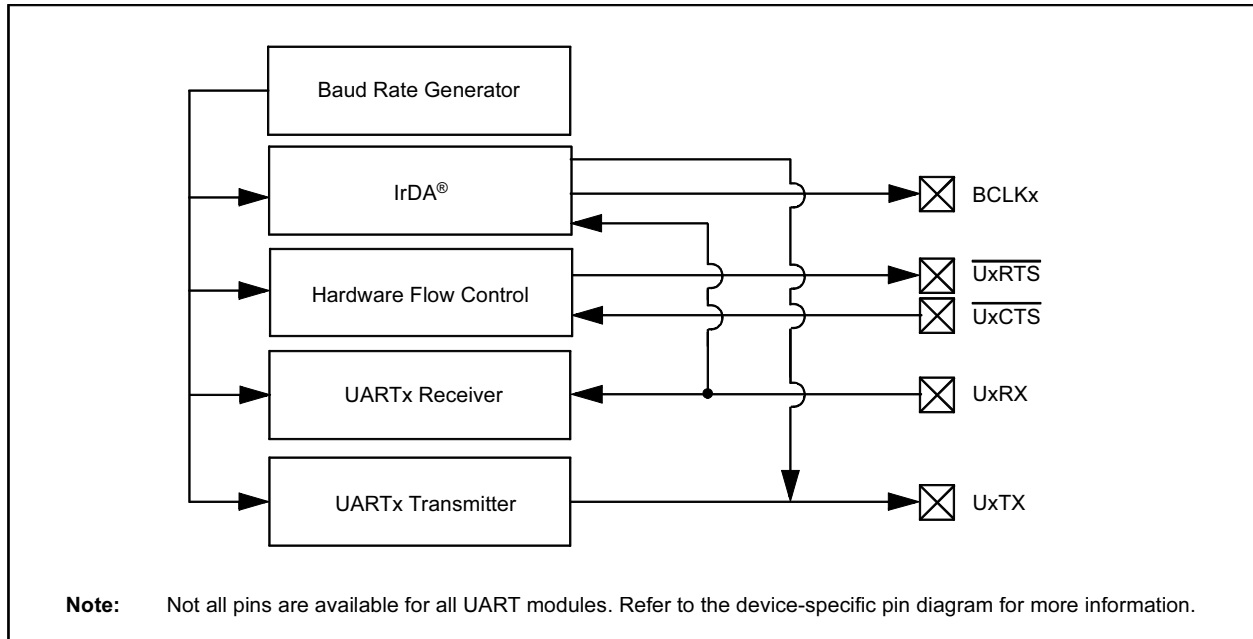

PIC32MX5XX/6XX/7XX

Figure 19-2 and Figure 19-3 illustrate typical receive and transmit timing for the UART module.

FIGURE 19-2: UART RECEPTION

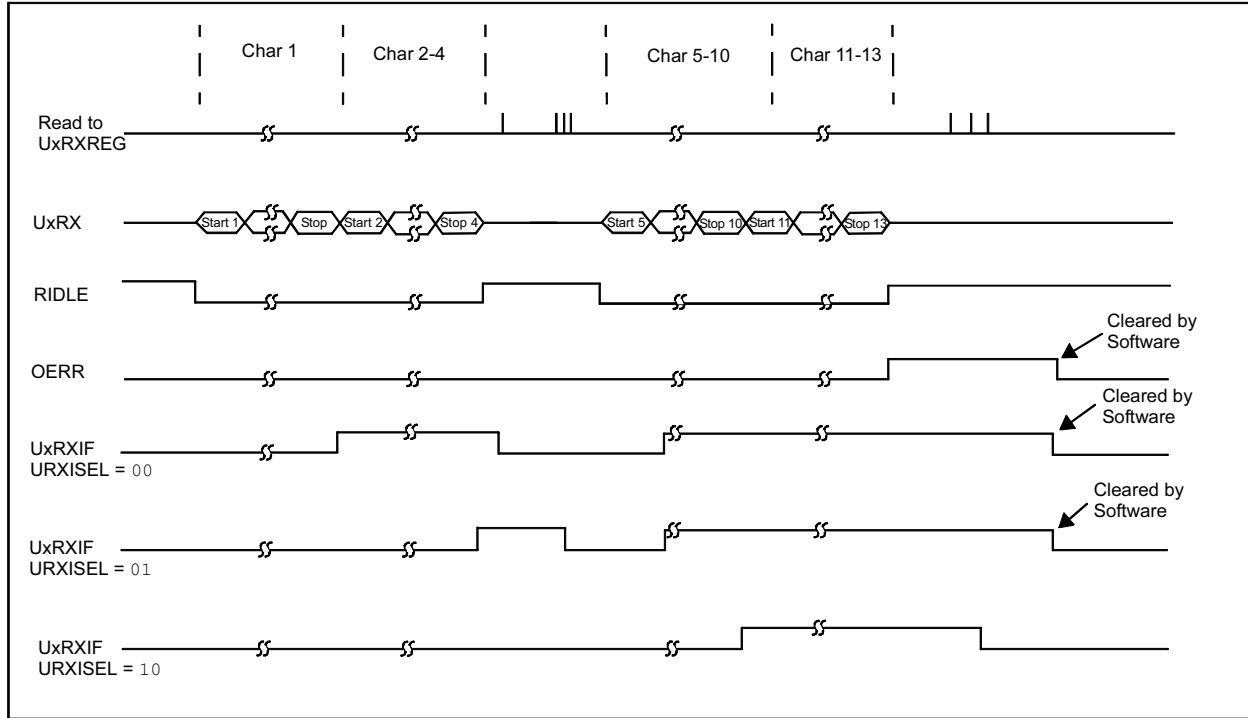
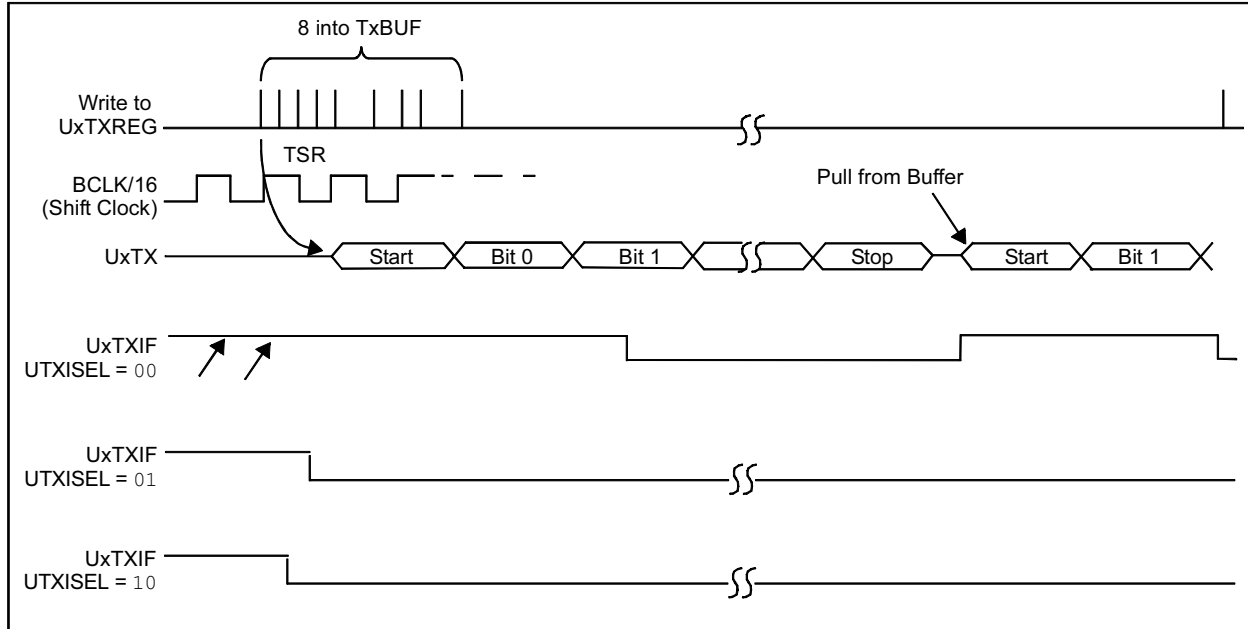

FIGURE 19-3: TRANSMISSION (8-BIT OR 9-BIT DATA)



20.0 PARALLEL MASTER PORT (PMP)

Note 1: This data sheet summarizes the features of the PIC32MX5XX/6XX/7XX family of devices. It is not intended to be a comprehensive reference source. To complement the information in this data sheet, refer to **Section 13. “Parallel Master Port (PMP)”** (DS61128) in the “PIC32 Family Reference Manual”, which is available from the Microchip web site (www.microchip.com/PIC32).

2: Some registers and associated bits described in this section may not be available on all devices. Refer to **Section 4.0 “Memory Organization”** in this data sheet for device-specific register and bit information.

The PMP is a parallel 8-bit/16-bit input/output module specifically designed to communicate with a wide variety of parallel devices, such as communications peripherals, LCDs, external memory devices and microcontrollers. Because the interface to parallel peripherals varies significantly, the PMP module is highly configurable. **Figure 20-1** shows the PMP module pinout and its connections to external devices.

Key features of the PMP module include:

- 8-bit, 16-bit interface
- Up to 16 programmable address lines
- Up to two Chip Select lines
- Programmable strobe options
 - Individual read and write strobes, or
 - Read/write strobe with enable strobe
- Address auto-increment/auto-decrement
- Programmable address/data multiplexing
- Programmable polarity on control signals
- Parallel Slave Port support
 - Legacy addressable
 - Address support
 - 4-byte deep auto-incrementing buffer
- Programmable wait states
- Operates during CPU Sleep and Idle modes
- Fast bit manipulation using CLR, SET and INV registers
- Freeze option for in-circuit debugging

Note: On 64-pin devices, the PMD<15:8> data pins are not available.

FIGURE 20-1: PMP MODULE PINOUT AND CONNECTIONS TO EXTERNAL DEVICES

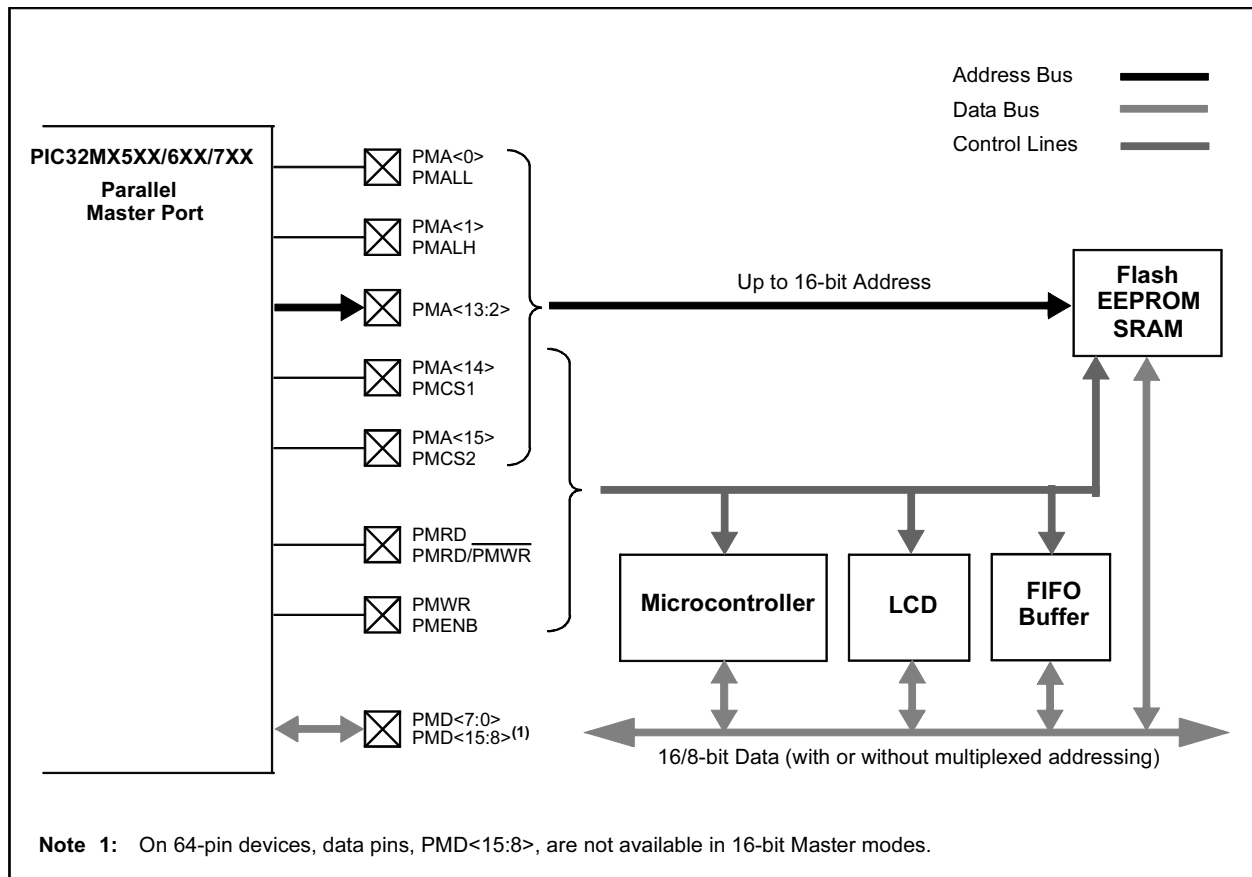

NOTES:

21.0 REAL-TIME CLOCK AND CALENDAR (RTCC)

Note 1: This data sheet summarizes the features of the PIC32MX5XX/6XX/7XX family of devices. It is not intended to be a comprehensive reference source. To complement the information in this data sheet, refer to **Section 29. “Real-Time Clock and Calendar (RTCC)”** (DS61125) in the “PIC32 Family Reference Manual”, which is available from the Microchip web site (www.microchip.com/PIC32).

2: Some registers and associated bits described in this section may not be available on all devices. Refer to **Section 4.0 “Memory Organization”** in this data sheet for device-specific register and bit information.

The PIC32 RTCC module is intended for applications in which accurate time must be maintained for extended periods of time with minimal or no CPU intervention. Low-power optimization provides extended battery lifetime while keeping track of time. A simplified block diagram of the RTCC module is illustrated in [Figure 21-1](#).

Following are some of the key features of this module:

- Time: hours, minutes and seconds
- 24-hour format (military time)
- Visibility of one-half second period
- Provides calendar: Weekday, date, month and year
- Alarm intervals are configurable for half of a second, one second, 10 seconds, one minute, 10 minutes, one hour, one day, one week, one month and one year
- Alarm repeat with decremting counter
- Alarm with indefinite repeat: Chime
- Year range: 2000 to 2099
- Leap year correction
- BCD format for smaller firmware overhead
- Optimized for long-term battery operation
- Fractional second synchronization
- User calibration of the clock crystal frequency with auto-adjust
- Calibration range: ± 0.66 seconds error per month
- Calibrates up to 260 ppm of crystal error
- Requirements: External 32.768 kHz clock crystal
- Alarm pulse or seconds clock output on RTCC pin

FIGURE 21-1: RTCC BLOCK DIAGRAM

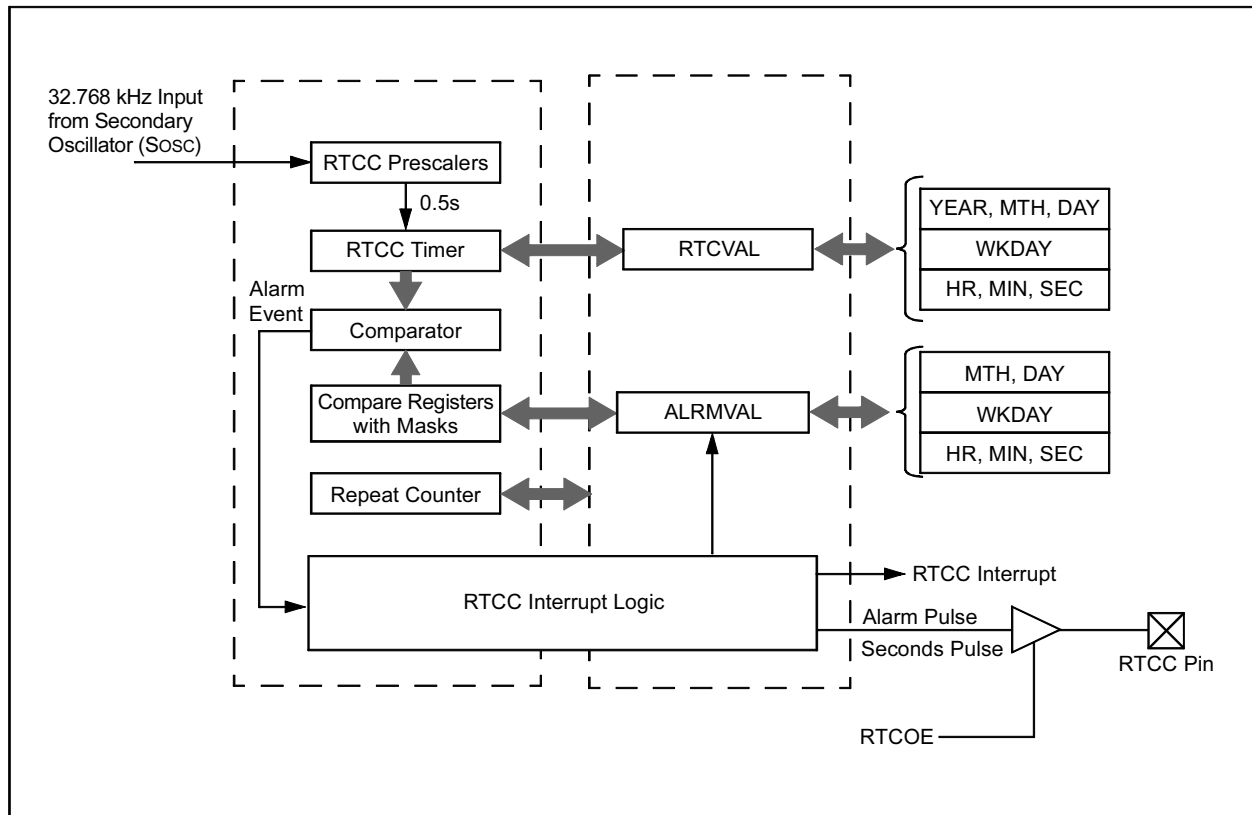

NOTES:

22.0 10-BIT ANALOG-TO-DIGITAL CONVERTER (ADC)

Note 1: This data sheet summarizes the features of the PIC32MX5XX/6XX/7XX family of devices. It is not intended to be a comprehensive reference source. To complement the information in this data sheet, refer to **Section 17. “10-bit Analog-to-Digital Converter (ADC)”** (DS61104) in the “PIC32 Family Reference Manual”, which is available from the Microchip web site (www.microchip.com/PIC32).

2: Some registers and associated bits described in this section may not be available on all devices. Refer to **Section 4.0 “Memory Organization”** in this data sheet for device-specific register and bit information.

The PIC32MX5XX/6XX/7XX 10-bit Analog-to-Digital Converter (ADC) includes the following features:

- Successive Approximation Register (SAR) conversion
- Up to 1 Msps conversion speed
- Up to 16 analog input pins
- External voltage reference input pins

- One unipolar, differential Sample and Hold Amplifier (SHA)
- Automatic Channel Scan mode
- Selectable conversion trigger source
- 16-word conversion result buffer
- Selectable buffer fill modes
- Eight conversion result format options
- Operation during CPU Sleep and Idle modes

A block diagram of the 10-bit ADC is illustrated in **Figure 22-1**. The 10-bit ADC has up to 16 analog input pins, designated AN0-AN15. In addition, there are two analog input pins for external voltage reference connections. These voltage reference inputs may be shared with other analog input pins and may be common to other analog module references.

The analog inputs are connected through two multiplexers (MUXs) to one SHA. The analog input MUXs can be switched between two sets of analog inputs between conversions. Unipolar differential conversions are possible on all channels, other than the pin used as the reference, using a reference input pin (see **Figure 22-1**).

The Analog Input Scan mode sequentially converts user-specified channels. A control register specifies which analog input channels will be included in the scanning sequence.

The 10-bit ADC is connected to a 16-word result buffer. Each 10-bit result is converted to one of eight 32-bit output formats when it is read from the result buffer.

FIGURE 22-1: ADC1 MODULE BLOCK DIAGRAM

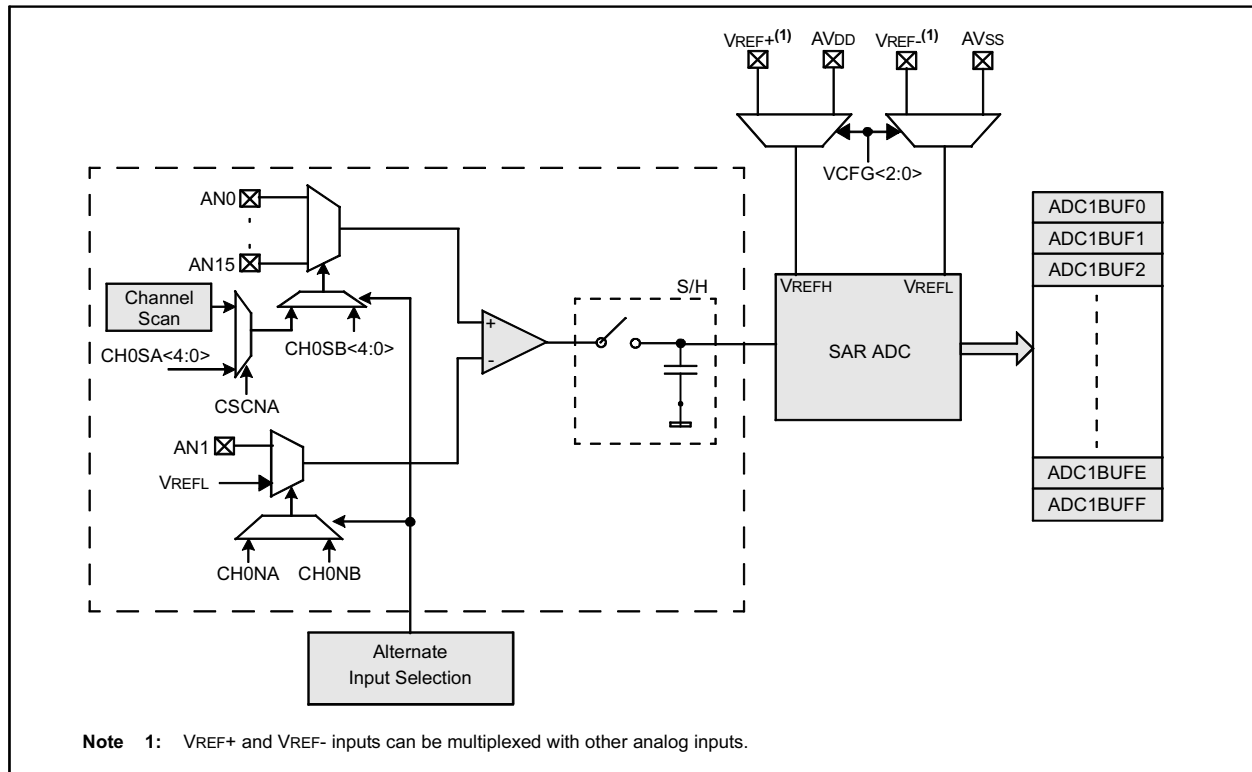
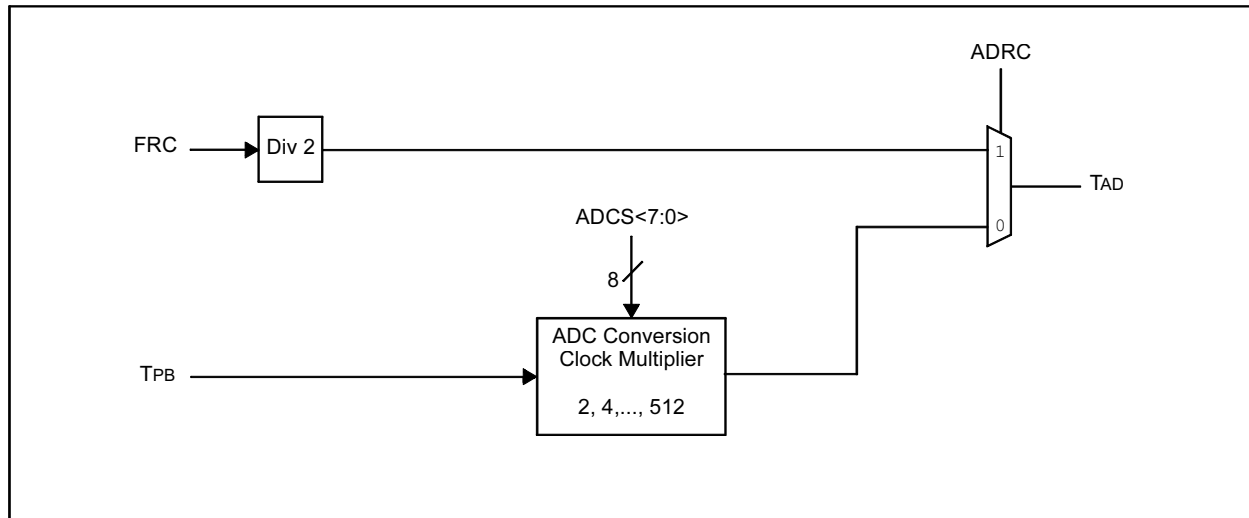

FIGURE 22-2: ADC CONVERSION CLOCK PERIOD BLOCK DIAGRAM



23.0 CONTROLLER AREA NETWORK (CAN)

Note 1: This data sheet summarizes the features of the PIC32MX5XX/6XX/7XX family of devices. It is not intended to be a comprehensive reference source. To complement the information in this data sheet, refer to **Section 34. “Controller Area Network (CAN)”** (DS61154) in the “PIC32 Family Reference Manual”, which is available from the Microchip web site (www.microchip.com/PIC32).

2: Some registers and associated bits described in this section may not be available on all devices. Refer to **Section 4.0 “Memory Organization”** in this data sheet for device-specific register and bit information.

The Controller Area Network (CAN) module supports the following key features:

- Standards Compliance:
 - Full CAN 2.0B compliance
 - Programmable bit rate up to 1 Mbps

- Message Reception and Transmission:
 - 32 message FIFOs
 - Each FIFO can have up to 32 messages for a total of 1024 messages
 - FIFO can be a transmit message FIFO or a receive message FIFO
 - User-defined priority levels for message FIFOs used for transmission
 - 32 acceptance filters for message filtering
 - Four acceptance filter mask registers for message filtering
 - Automatic response to remote transmit request
 - DeviceNet™ addressing support
- Additional Features:
 - Loopback, Listen All Messages and Listen Only modes for self-test, system diagnostics and bus monitoring
 - Low-power operating modes
 - CAN module is a bus master on the PIC32 system bus
 - Use of DMA is not required
 - Dedicated time-stamp timer
 - Dedicated DMA channels
 - Data-only Message Reception mode

Figure 23-1 illustrates the general structure of the CAN module.

FIGURE 23-1: PIC32 CAN MODULE BLOCK DIAGRAM

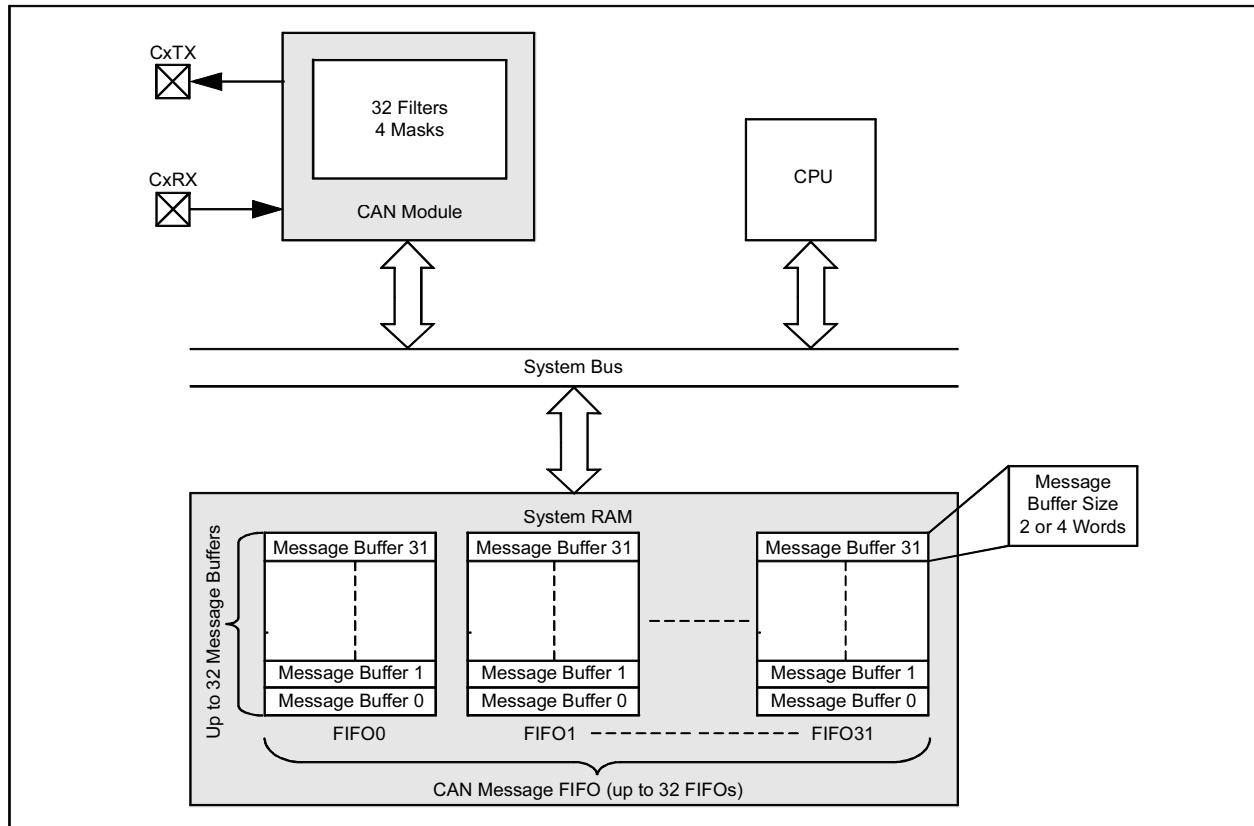

NOTES:

24.0 ETHERNET CONTROLLER

Note 1: This data sheet summarizes the features of the PIC32MX5XX/6XX/7XX family of devices. It is not intended to be a comprehensive reference source. To complement the information in this data sheet, refer to **Section 35. “Ethernet Controller”** (DS61155) in the *“PIC32 Family Reference Manual”*, which is available from the Microchip web site (www.microchip.com/PIC32).

2: Some registers and associated bits described in this section may not be available on all devices. Refer to **Section 4.0 “Memory Organization”** in this data sheet for device-specific register and bit information.

The Ethernet controller is a bus master module that interfaces with an off-chip Physical Layer (PHY) to implement a complete Ethernet node in a system.

Following are some of the key features of this module:

- Supports 10/100 Mbps data transfer rates
- Supports full-duplex and half-duplex operation
- Supports RMI and MII PHY interface
- Supports MIIM PHY management interface
- Supports both manual and automatic flow control
- RAM descriptor-based DMA operation for both receive and transmit path
- Fully configurable interrupts
- Configurable receive packet filtering
 - CRC check
 - 64-byte pattern match
 - Broadcast, multicast and unicast packets
 - Magic Packet™
 - 64-bit hash table
 - Runt packet
- Supports packet payload checksum calculation
- Supports various hardware statistics counters

Figure 24-1 illustrates a block diagram of the Ethernet controller.

FIGURE 24-1: ETHERNET CONTROLLER BLOCK DIAGRAM

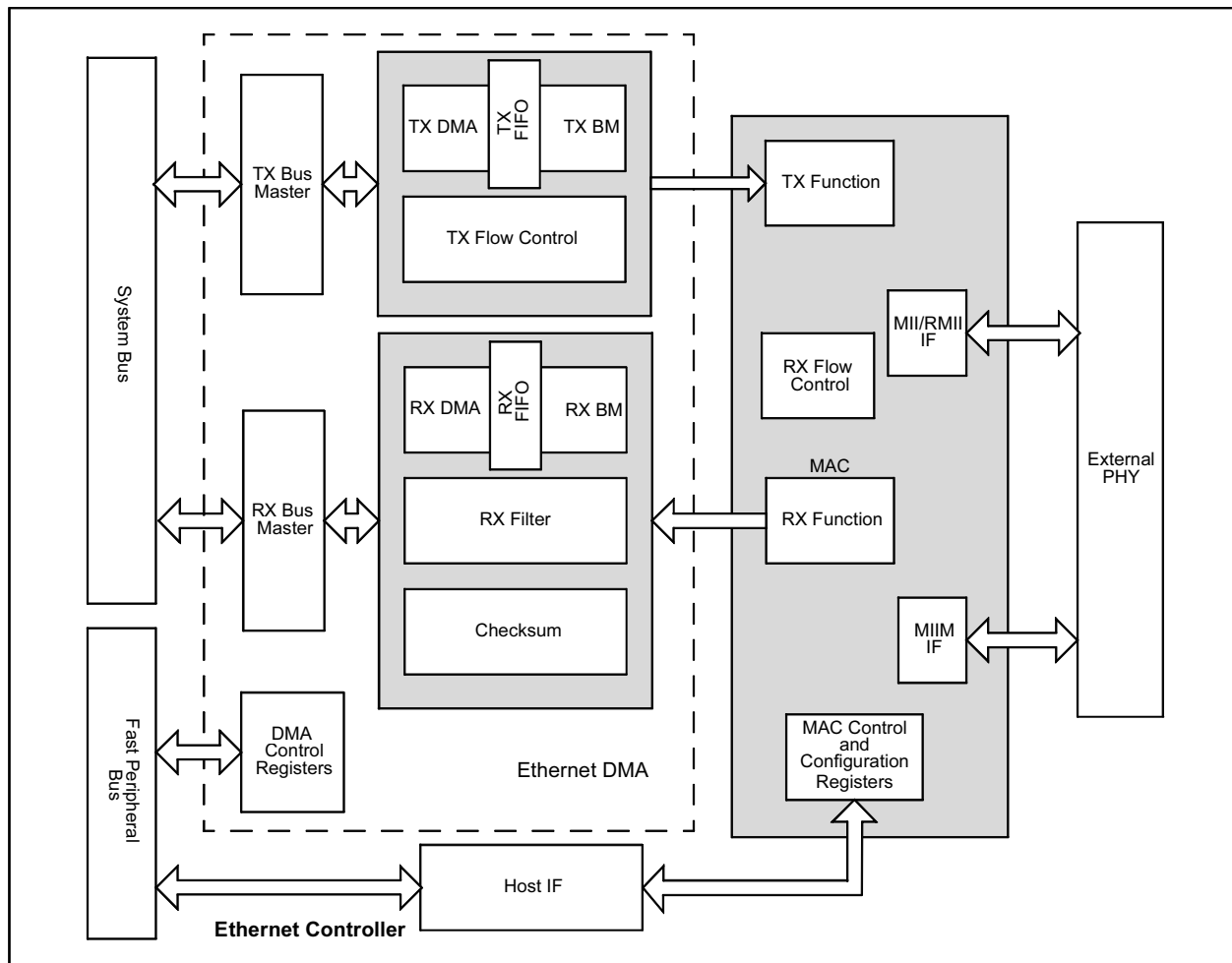

PIC32MX5XX/6XX/7XX

Table 24-1, Table 24-2, Table 24-3 and Table 24-4 show four interfaces and the associated pins that can be used with the Ethernet Controller.

TABLE 24-1: MII MODE DEFAULT INTERFACE SIGNALS (FMIEN = 1, FETHIO = 1)

Pin Name	Description
EMDC	Management Clock
EMDIO	Management I/O
ETXCLK	Transmit Clock
ETXEN	Transmit Enable
ETXD0	Transmit Data
ETXD1	Transmit Data
ETXD2	Transmit Data
ETXD3	Transmit Data
ETXERR	Transmit Error
ERXCLK	Receive Clock
ERXDV	Receive Data Valid
ERXD0	Receive Data
ERXD1	Receive Data
ERXD2	Receive Data
ERXD3	Receive Data
ERXERR	Receive Error
ECRS	Carrier Sense
ECOL	Collision Indication

TABLE 24-2: RMII MODE DEFAULT INTERFACE SIGNALS (FMIEN = 0, FETHIO = 1)

Pin Name	Description
EMDC	Management Clock
EMDIO	Management I/O
ETXEN	Transmit Enable
ETXD0	Transmit Data
ETXD1	Transmit Data
EREFCLK	Reference Clock
ECRSDV	Carrier Sense – Receive Data Valid
ERXD0	Receive Data
ERXD1	Receive Data
ERXERR	Receive Error

Note: Ethernet controller pins that are not used by selected interface can be used by other peripherals.

TABLE 24-3: MII MODE ALTERNATE INTERFACE SIGNALS (FMIEN = 1, FETHIO = 0)⁽¹⁾

Pin Name	Description
AEMDC	Management Clock
AEMDIO	Management I/O
AETXCLK	Transmit Clock
AETXEN	Transmit Enable
AETXD0	Transmit Data
AETXD1	Transmit Data
AETXD2	Transmit Data
AETXD3	Transmit Data
AETXERR	Transmit Error
AERXCLK	Receive Clock
AERXDV	Receive Data Valid
AERXD0	Receive Data
AERXD1	Receive Data
AERXD2	Receive Data
AERXD3	Receive Data
AERXERR	Receive Error
AECRS	Carrier Sense
AECOL	Collision Indication

Note 1: MII Alternate Interface is not available on 64-pin devices.

TABLE 24-4: RMII MODE ALTERNATE INTERFACE SIGNALS (FMIEN = 0, FETHIO = 0)

Pin Name	Description
AEMDC	Management Clock
AEMDIO	Management I/O
AETXEN	Transmit Enable
AETXD0	Transmit Data
AETXD1	Transmit Data
AEREFCLK	Reference Clock
AECRSDV	Carrier Sense – Receive Data Valid
AERXD0	Receive Data
AERXD1	Receive Data
AERXERR	Receive Error

25.0 COMPARATOR

Note 1: This data sheet summarizes the features of the PIC32MX5XX/6XX/7XX family of devices. It is not intended to be a comprehensive reference source. To complement the information in this data sheet, refer to **Section 19. “Comparator”** (DS61110) in the “PIC32 Family Reference Manual”, which is available from the Microchip web site (www.microchip.com/PIC32).

2: Some registers and associated bits described in this section may not be available on all devices. Refer to **Section 4.0 “Memory Organization”** in this data sheet for device-specific register and bit information.

The Analog Comparator module contains two comparators that can be configured in a variety of ways.

Following are some of the key features of this module:

- Selectable inputs available include:
 - Analog inputs multiplexed with I/O pins
 - On-chip internal absolute voltage reference (IVREF)
 - Comparator voltage reference (CVREF)
- Outputs can be Inverted
- Selectable interrupt generation

A block diagram of the Comparator module is illustrated in **Figure 25-1**.

FIGURE 25-1: COMPARATOR BLOCK DIAGRAM

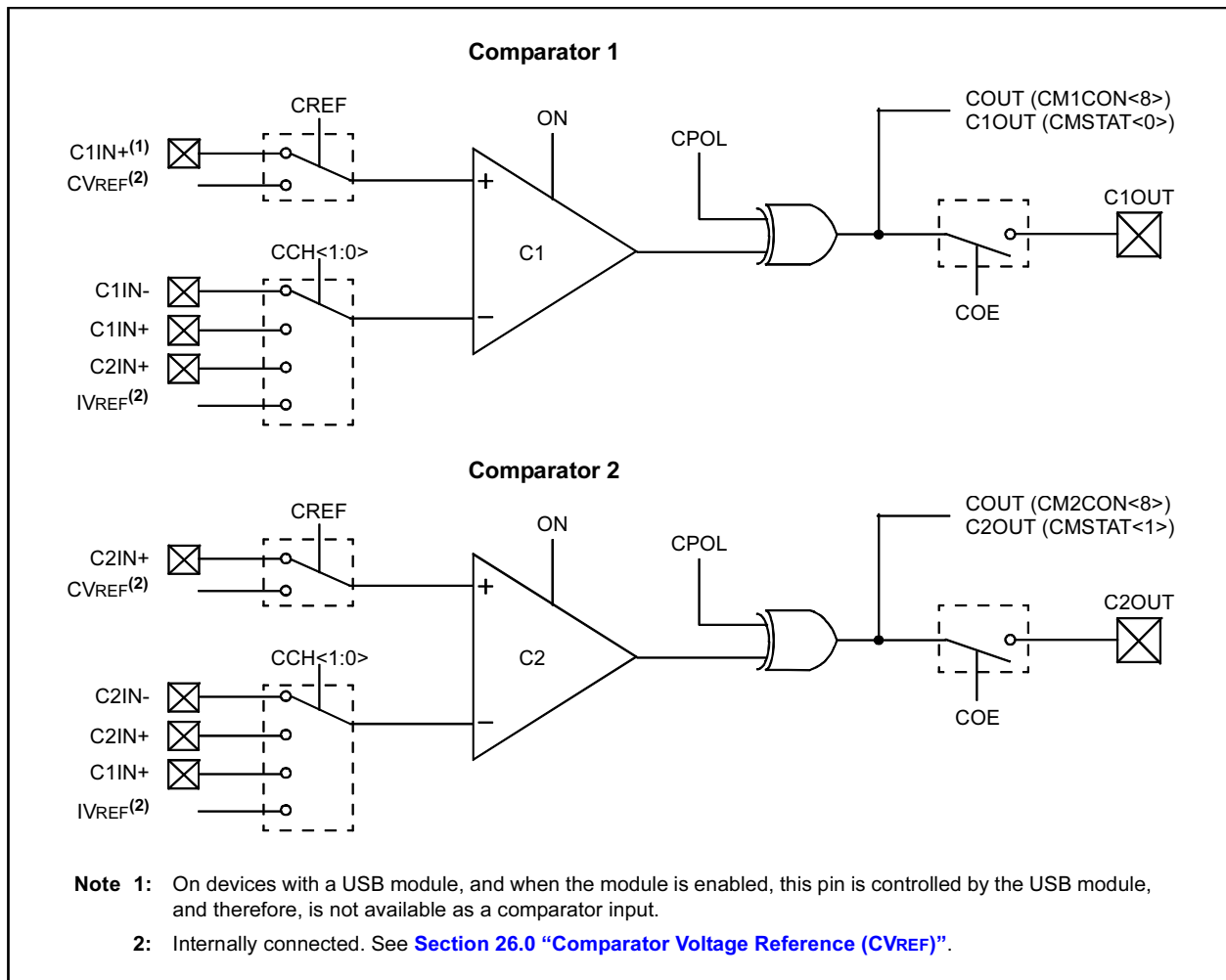

NOTES:

26.0 COMPARATOR VOLTAGE REFERENCE (CVREF)

Note 1: This data sheet summarizes the features of the PIC32MX5XX/6XX/7XX family of devices. It is not intended to be a comprehensive reference source. To complement the information in this data sheet, refer to **Section 20. “Comparator Voltage Reference (CVREF)”** (DS61109) in the “PIC32 Family Reference Manual”, which is available from the Microchip web site (www.microchip.com/PIC32).

2: Some registers and associated bits described in this section may not be available on all devices. Refer to **Section 4.0 “Memory Organization”** in this data sheet for device-specific register and bit information.

The CVREF module is a 16-tap, resistor ladder network that provides a selectable reference voltage. Although its primary purpose is to provide a reference for the analog comparators, it also may be used independently of them.

A block diagram of the module is illustrated in **Figure 26-1**. The resistor ladder is segmented to provide two ranges of voltage reference values and has a power-down function to conserve power when the reference is not being used. The module’s supply reference can be provided from either device VDD/VSS or an external voltage reference. The CVREF output is available for the comparators and typically available for pin output.

The comparator voltage reference has the following features:

- High and low range selection
- Sixteen output levels available for each range
- Internally connected to comparators to conserve device pins
- Output can be connected to a pin

FIGURE 26-1: COMPARATOR VOLTAGE REFERENCE BLOCK DIAGRAM

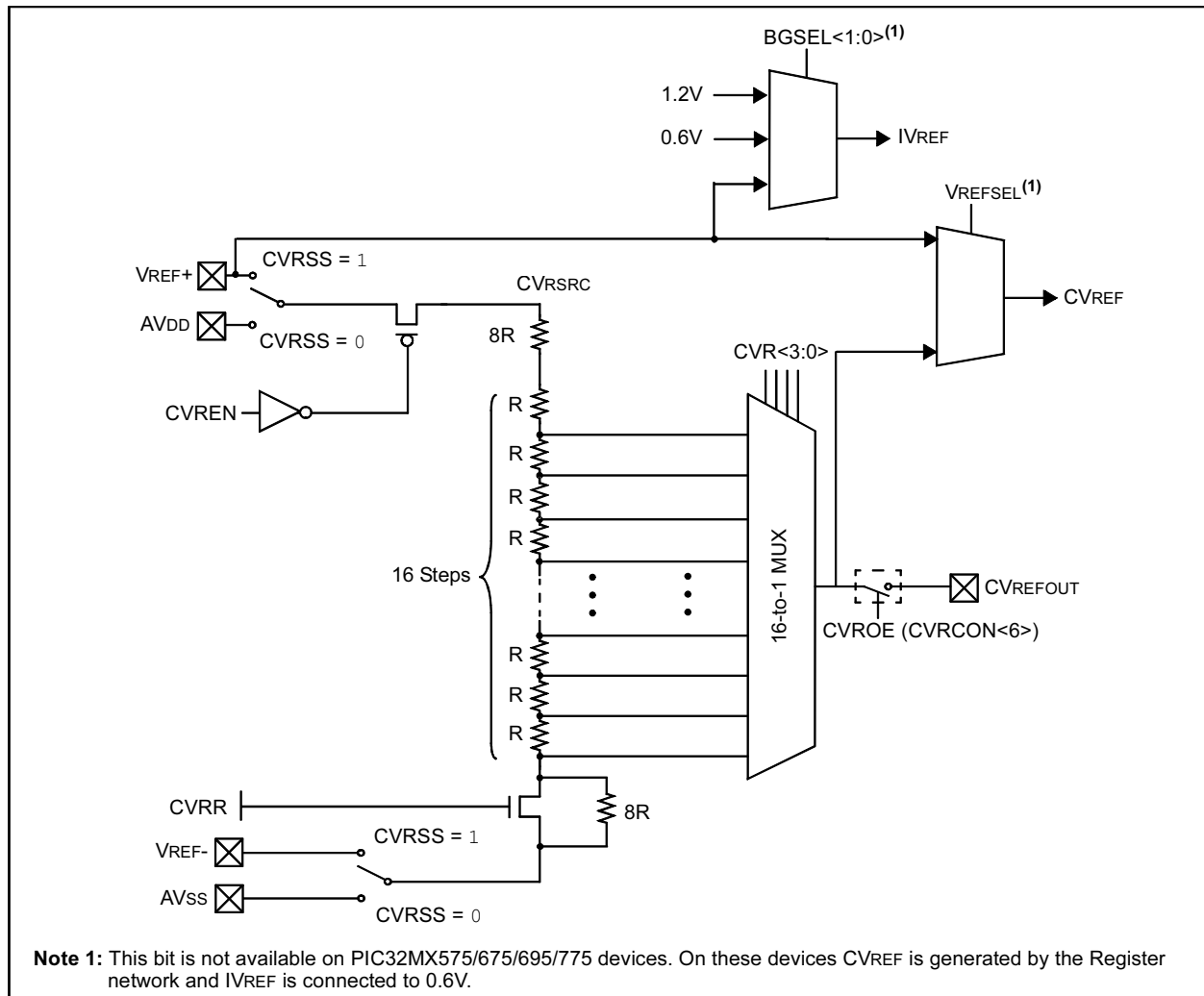

NOTES:

27.0 POWER-SAVING FEATURES

Note 1: This data sheet summarizes the features of the PIC32MX5XX/6XX/7XX family of devices. It is not intended to be a comprehensive reference source. To complement the information in this data sheet, refer to **Section 10. “Power-Saving Features”** (DS61130) in the *“PIC32 Family Reference Manual”*, which is available from the Microchip web site (www.microchip.com/PIC32).

2: Some registers and associated bits described in this section may not be available on all devices. Refer to **Section 4.0 “Memory Organization”** in this data sheet for device-specific register and bit information.

This section describes power-saving features for the PIC32MX5XX/6XX/7XX family of devices. These devices offer a total of nine methods and modes, organized into two categories, that allow the user to balance power consumption with device performance. In all of the methods and modes described in this section, power-saving is controlled by software.

27.1 Power-Saving with CPU Running

When the CPU is running, power consumption can be controlled by reducing the CPU clock frequency, lowering the PBCLK and by individually disabling modules. These methods are grouped into the following categories:

- FRC Run mode: the CPU is clocked from the FRC clock source with or without postscalers.
- LPRC Run mode: the CPU is clocked from the LPRC clock source.
- Sosc Run mode: the CPU is clocked from the Sosc clock source.

In addition, the Peripheral Bus Scaling mode is available where peripherals are clocked at the programmable fraction of the CPU clock (SYSCLK).

27.2 CPU Halted Methods

The device supports two power-saving modes, Sleep and Idle, both of which Halt the clock to the CPU. These modes operate with all clock sources, as listed below:

- Posc Idle mode: the system clock is derived from the Posc. The system clock source continues to operate. Peripherals continue to operate, but can optionally be individually disabled.
- FRC Idle mode: the system clock is derived from the FRC with or without postscalers. Peripherals continue to operate, but can optionally be individually disabled.
- Sosc Idle mode: the system clock is derived from the Sosc. Peripherals continue to operate, but can optionally be individually disabled.

- LPRC Idle mode: the system clock is derived from the LPRC. Peripherals continue to operate, but can optionally be individually disabled. This is the lowest power mode for the device with a clock running.
- Sleep mode: the CPU, the system clock source and any peripherals that operate from the system clock source are Halted. Some peripherals can operate in Sleep using specific clock sources. This is the lowest power mode for the device.

27.3 Power-Saving Operation

Peripherals and the CPU can be halted or disabled to further reduce power consumption.

27.3.1 SLEEP MODE

Sleep mode has the lowest power consumption of the device power-saving operating modes. The CPU and most peripherals are halted. Select peripherals can continue to operate in Sleep mode and can be used to wake the device from Sleep. See the individual peripheral module sections for descriptions of behavior in Sleep.

Sleep mode includes the following characteristics:

- The CPU is halted
- The system clock source is typically shutdown. See **Section 27.3.3 “Peripheral Bus Scaling Method”** for specific information.
- There can be a wake-up delay based on the oscillator selection
- The Fail-Safe Clock Monitor (FSCM) does not operate during Sleep mode
- The BOR circuit, if enabled, remains operative during Sleep mode
- The WDT, if enabled, is not automatically cleared prior to entering Sleep mode
- Some peripherals can continue to operate at limited functionality in Sleep mode. These peripherals include I/O pins that detect a change in the input signal, WDT, ADC, UART and peripherals that use an external clock input or the internal LPRC oscillator (e.g., RTCC, Timer1 and Input Capture).
- I/O pins continue to sink or source current in the same manner as they do when the device is not in Sleep
- Modules can be individually disabled by software prior to entering Sleep in order to further reduce consumption

The processor will exit, or 'wake-up', from Sleep on one of the following events:

- On any interrupt from an enabled source that is operating in Sleep. The interrupt priority must be greater than the current CPU priority.
- On any form of device Reset
- On a WDT time-out

If the interrupt priority is lower than or equal to the current priority, the CPU will remain Halted, but the PBCLK will start running and the device will enter into Idle mode.

27.3.2 IDLE MODE

In Idle mode, the CPU is Halted but the System Clock (SYSCLK) source is still enabled. This allows peripherals to continue operation when the CPU is Halted. Peripherals can be individually configured to Halt when entering Idle by setting their respective SIDL bit. Latency, when exiting Idle mode, is very low due to the CPU oscillator source remaining active.

Note 1: Changing the PBCLK divider ratio requires recalculation of peripheral timing. For example, assume the UART is configured for 9600 baud with a PB clock ratio of 1:1 and a Posc of 8 MHz. When the PB clock divisor of 1:2 is used, the input frequency to the baud clock is cut in half; therefore, the baud rate is reduced to 1/2 its former value. Due to numeric truncation in calculations (such as the baud rate divisor), the actual baud rate may be a tiny percentage different than expected. For this reason, any timing calculation required for a peripheral should be performed with the new PB clock frequency instead of scaling the previous value based on a change in the PB divisor ratio.

- 2:** Oscillator start-up and PLL lock delays are applied when switching to a clock source that was disabled and that uses a crystal and/or the PLL. For example, assume the clock source is switched from Posc to LPRC just prior to entering Sleep in order to save power. No oscillator start-up delay would be applied when exiting Idle. However, when switching back to Posc, the appropriate PLL and/or oscillator start-up/lock delays would be applied.

The device enters Idle mode when the SLPEN bit (OSCCON<4>) is clear and a WAIT instruction is executed.

The processor will wake or exit from Idle mode on the following events:

- On any interrupt event for which the interrupt source is enabled. The priority of the interrupt event must be greater than the current priority of the CPU. If the priority of the interrupt event is lower than or equal to current priority of the CPU, the CPU will remain Halted and the device will remain in Idle mode.
- On any form of device Reset
- On a WDT time-out interrupt

27.3.3 PERIPHERAL BUS SCALING METHOD

Most of the peripherals on the device are clocked using the PBCLK. The peripheral bus can be scaled relative to the SYSCLK to minimize the dynamic power consumed by the peripherals. The PBCLK divisor is controlled by PBDIV<1:0> (OSCCON<20:19>), allowing SYSCLK to PBCLK ratios of 1:1, 1:2, 1:4 and 1:8. All peripherals using PBCLK are affected when the divisor is changed. Peripherals such as USB, interrupt controller, DMA, bus matrix and prefetch cache are clocked directly from SYSCLK. As a result, they are not affected by PBCLK divisor changes.

Changing the PBCLK divisor affects:

- The CPU to peripheral access latency. The CPU has to wait for next PBCLK edge for a read to complete. In 1:8 mode, this results in a latency of one to seven SYSCLKs.
- The power consumption of the peripherals. Power consumption is directly proportional to the frequency at which the peripherals are clocked. The greater the divisor, the lower the power consumed by the peripherals.

To minimize dynamic power, the PB divisor should be chosen to run the peripherals at the lowest frequency that provides acceptable system performance. When selecting a PBCLK divider, peripheral clock requirements, such as baud rate accuracy, should be taken into account. For example, the UART peripheral may not be able to achieve all baud rate values at some PBCLK divider depending on the SYSCLK value.

28.0 SPECIAL FEATURES

Note: This data sheet summarizes the features of the PIC32MX5XX/6XX/7XX family of devices. However, it is not intended to be a comprehensive reference source. To complement the information in this data sheet, refer to **Section 8. “Watchdog Timer and Power-up Timer”** (DS61114), **Section 24. “Configuration”** (DS61124) and **Section 33. “Programming and Diagnostics”** (DS61129) in the *“PIC32 Family Reference Manual”* (DS61132), which is available from the Microchip web site (www.microchip.com/PIC32).

PIC32MX5XX/6XX/7XX devices include several features intended to maximize application flexibility and reliability and minimize cost through elimination of external components. These are:

- Flexible device configuration
- Watchdog Timer (WDT)
- Joint Test Action Group (JTAG) interface
- In-Circuit Serial Programming™ (ICSP™)

28.1 Configuration Bits

The Configuration bits can be programmed using the following registers to select various device configurations.

- [DEVCFG0: Device Configuration Word 0](#)
- [DEVCFG1: Device Configuration Word 1](#)
- [DEVCFG2: Device Configuration Word 2](#)
- [DEVCFG3: Device Configuration Word 3](#)
- [DEVID: Device and Revision ID Register](#)

PIC32MX5XX/6XX/7XX

REGISTER 28-1: DEVCFG0: DEVICE CONFIGURATION WORD 0

Bit Range	Bit 31/23/15/7	Bit 30/22/14/6	Bit 29/21/13/5	Bit 28/20/12/4	Bit 27/19/11/3	Bit 26/18/10/2	Bit 25/17/9/1	Bit 24/16/8/0
31:24	r-0	r-1	r-1	R/P	r-1	r-1	r-1	R/P
	—	—	—	CP	—	—	—	BWP
23:16	r-1	r-1	r-1	r-1	R/P	R/P	R/P	R/P
	—	—	—	—	PWP<7:4>			
15:8	R/P	R/P	R/P	R/P	r-1	r-1	r-1	r-1
	PWP<3:0>				—	—	—	—
7:0	r-1	r-1	r-1	r-1	R/P	r-1	R/P	R/P
	—	—	—	—	ICASEL	—	DEBUG<1:0>	

Legend:

R = Readable bit	W = Writable bit	P = Programmable bit	r = Reserved bit
U = Unimplemented bit	'1' = Bit is set	'0' = Bit is cleared	x = Bit is unknown

bit 31 **Reserved:** Write '0'

bit 30-29 **Reserved:** Write '1'

bit 28 **CP:** Code-Protect bit

Prevents boot and program Flash memory from being read or modified by an external programming device.

1 = Protection is disabled

0 = Protection is enabled

bit 27-25 **Reserved:** Write '1'

bit 24 **BWP:** Boot Flash Write-Protect bit

Prevents boot Flash memory from being modified during code execution.

1 = Boot Flash is writable

0 = Boot Flash is not writable

bit 23-20 **Reserved:** Write '1'

bit 19-12 **PWP<7:0>:** Program Flash Write-Protect bits

Prevents selected program Flash memory pages from being modified during code execution. The PWP bits represent the 1's complement of the number of write-protected program Flash memory pages.

11111111 = Disabled

11111110 = 0xBD00_0FFF

11111101 = 0xBD00_1FFF

11111100 = 0xBD00_2FFF

11111011 = 0xBD00_3FFF

11111010 = 0xBD00_4FFF

11111001 = 0xBD00_5FFF

11111000 = 0xBD00_6FFF

11110111 = 0xBD00_7FFF

11110110 = 0xBD00_8FFF

11110101 = 0xBD00_9FFF

11110100 = 0xBD00_AFFF

11110011 = 0xBD00_BFFF

11110010 = 0xBD00_CFFF

11110001 = 0xBD00_DFFF

11110000 = 0xBD00_EFFF

11101111 = 0xBD00_FFFF

•

•

•

01111111 = 0xBD07_FFFF

REGISTER 28-1: DEVCFG0: DEVICE CONFIGURATION WORD 0 (CONTINUED)

bit 11-4 **Reserved:** Write '1'

bit 3 **ICESEL:** In-Circuit Emulator/Debugger Communication Channel Select bit

1 = PGEC2/PGED2 pair is used

0 = PGEC1/PGED1 pair is used

bit 2 **Reserved:** Write '1'

bit 1-0 **DEBUG<1:0>:** Background Debugger Enable bits (forced to '11' if code-protect is enabled)

11 = Debugger is disabled

10 = Debugger is enabled

01 = Reserved (same as '11' setting)

00 = Reserved (same as '11' setting)

PIC32MX5XX/6XX/7XX

REGISTER 28-2: DEVCFG1: DEVICE CONFIGURATION WORD 1

Bit Range	Bit 31/23/15/7	Bit 30/22/14/6	Bit 29/21/13/5	Bit 28/20/12/4	Bit 27/19/11/3	Bit 26/18/10/2	Bit 25/17/9/1	Bit 24/16/8/0
31:24	r-1	r-1	r-1	r-1	r-1	r-1	r-1	r-1
	—	—	—	—	—	—	—	—
23:16	R/P	r-1	r-1	R/P	R/P	R/P	R/P	R/P
	FWDTEN	—	—	WDTPS<4:0>				
15:8	R/P	R/P	R/P	R/P	r-1	R/P	R/P	R/P
	FCKSM<1:0>		FPBDIV<1:0>		—	OSCIOFNC	POSCMOD<1:0>	
7:0	R/P	r-1	R/P	r-1	r-1	R/P	R/P	R/P
	IESO	—	FSOSCEN	—	—	FNOSC<2:0>		

Legend:

R = Readable bit W = Writable bit P = Programmable bit r = Reserved bit
 U = Unimplemented bit '1' = Bit is set '0' = Bit is cleared x = Bit is unknown

bit 31-24 **Reserved:** Write '1'

bit 23 **FWDTEN:** Watchdog Timer Enable bit

1 = The WDT is enabled and cannot be disabled by software
 0 = The WDT is not enabled; it can be enabled in software

bit 22-21 **Reserved:** Write '1'

bit 20-16 **WDTPS<4:0>:** Watchdog Timer Postscale Select bits

10100 = 1:1048576
 10011 = 1:524288
 10010 = 1:262144
 10001 = 1:131072
 10000 = 1:65536
 01111 = 1:32768
 01110 = 1:16384
 01101 = 1:8192
 01100 = 1:4096
 01011 = 1:2048
 01010 = 1:1024
 01001 = 1:512
 01000 = 1:256
 00111 = 1:128
 00110 = 1:64
 00101 = 1:32
 00100 = 1:16
 00011 = 1:8
 00010 = 1:4
 00001 = 1:2
 00000 = 1:1

All other combinations not shown result in operation = 10100

bit 15-14 **FCKSM<1:0>:** Clock Switching and Monitor Selection Configuration bits

1x = Clock switching is disabled, Fail-Safe Clock Monitor is disabled
 01 = Clock switching is enabled, Fail-Safe Clock Monitor is disabled
 00 = Clock switching is enabled, Fail-Safe Clock Monitor is enabled

Note 1: Do not disable the Posc (POSCMOD = 11) when using this oscillator source.

REGISTER 28-2: DEVCFG1: DEVICE CONFIGURATION WORD 1 (CONTINUED)

bit 13-12 **FPBDIV<1:0>**: Peripheral Bus Clock Divisor Default Value bits

- 11 = PBCLK is SYSCLK divided by 8
- 10 = PBCLK is SYSCLK divided by 4
- 01 = PBCLK is SYSCLK divided by 2
- 00 = PBCLK is SYSCLK divided by 1

bit 11 **Reserved**: Write '1'

bit 10 **OSCIOFNC**: CLKO Enable Configuration bit

- 1 = CLKO output disabled
- 0 = CLKO output signal active on the OSCO pin; Primary Oscillator must be disabled or configured for the External Clock mode (EC) for the CLKO to be active (POSCMOD<1:0> = 11 or 00)

bit 9-8 **POSCMOD<1:0>**: Primary Oscillator Configuration bits

- 11 = Primary Oscillator disabled
- 10 = HS Oscillator mode selected
- 01 = XT Oscillator mode selected
- 00 = External Clock mode selected

bit 7 **IESO**: Internal External Switchover bit

- 1 = Internal External Switchover mode is enabled (Two-Speed Start-up is enabled)
- 0 = Internal External Switchover mode is disabled (Two-Speed Start-up is disabled)

bit 6 **Reserved**: Write '1'

bit 5 **FSOSCEN**: Secondary Oscillator Enable bit

- 1 = Enable Secondary Oscillator
- 0 = Disable Secondary Oscillator

bit 4-3 **Reserved**: Write '1'

bit 2-0 **FNOSC<2:0>**: Oscillator Selection bits

- 111 = Fast RC Oscillator with divide-by-N (FRCDIV)
- 110 = FRCDIV16 Fast RC Oscillator with fixed divide-by-16 postscaler
- 101 = Low-Power RC Oscillator (LPRC)
- 100 = Secondary Oscillator (Sosc)
- 011 = Primary Oscillator (Posc) with PLL module (XT+PLL, HS+PLL, EC+PLL)
- 010 = Primary Oscillator (XT, HS, EC)⁽¹⁾
- 001 = Fast RC Oscillator with divide-by-N with PLL module (FRCDIV+PLL)
- 000 = Fast RC Oscillator (FRC)

Note 1: Do not disable the Posc (POSCMOD = 11) when using this oscillator source.

PIC32MX5XX/6XX/7XX

REGISTER 28-3: DEVCFG2: DEVICE CONFIGURATION WORD 2

Bit Range	Bit 31/23/15/7	Bit 30/22/14/6	Bit 29/21/13/5	Bit 28/20/12/4	Bit 27/19/11/3	Bit 26/18/10/2	Bit 25/17/9/1	Bit 24/16/8/0
31:24	r-1 —	r-1 —	r-1 —	r-1 —	r-1 —	r-1 —	r-1 —	r-1 —
23:16	r-1 —	r-1 —	r-1 —	r-1 —	r-1 —	R/P —	R/P —	R/P —
15:8	R/P UPLLEN	r-1 —	r-1 —	r-1 —	r-1 —	R/P —	R/P —	R/P —
	FPLLIDIV<2:0>						UPLLDIV<2:0>	
7:0	r-1 —	R/P-1 —	R/P —	R/P-1 —	r-1 —	R/P —	R/P —	R/P —
	FPLLMUL<2:0>				FPLLIDIV<2:0>			

Legend:

R = Readable bit W = Writable bit P = Programmable bit r = Reserved bit
U = Unimplemented bit '1' = Bit is set '0' = Bit is cleared x = Bit is unknown

bit 31-19 **Reserved:** Write '1'

bit 18-16 **FPLLIDIV<2:0>**: Default Postscaler for PLL bits

111 = PLL output divided by 256
110 = PLL output divided by 64
101 = PLL output divided by 32
100 = PLL output divided by 16
011 = PLL output divided by 8
010 = PLL output divided by 4
001 = PLL output divided by 2
000 = PLL output divided by 1

bit 15 **UPLLEN**: USB PLL Enable bit

1 = Disable and bypass USB PLL
0 = Enable USB PLL

bit 14-11 **Reserved:** Write '1'

bit 10-8 **UPLLDIV<2:0>**: PLL Input Divider bits

111 = 12x divider
110 = 10x divider
101 = 6x divider
100 = 5x divider
011 = 4x divider
010 = 3x divider
010 = 3x divider
001 = 2x divider
000 = 1x divider

bit 7 **Reserved:** Write '1'

bit 6-4 **FPLLMUL<2:0>**: PLL Multiplier bits

111 = 24x multiplier
110 = 21x multiplier
101 = 20x multiplier
100 = 19x multiplier
011 = 18x multiplier
010 = 17x multiplier
001 = 16x multiplier
000 = 15x multiplier

bit 3 **Reserved:** Write '1'

bit 2-0 **FPLLIDIV<2:0>**: PLL Input Divider bits

111 = 12x divider
110 = 10x divider
101 = 6x divider
100 = 5x divider
011 = 4x divider
010 = 3x divider
001 = 2x divider
000 = 1x divider

REGISTER 28-4: DEVCFG3: DEVICE CONFIGURATION WORD 3

Bit Range	Bit 31/23/15/7	Bit 30/22/14/6	Bit 29/21/13/5	Bit 28/20/12/4	Bit 27/19/11/3	Bit 26/18/10/2	Bit 25/17/9/1	Bit 24/16/8/0
31:24	R/P	R/P	r-1	r-1	r-1	R/P	R/P	R/P
	FVBUSONIO	FUSBIDIO	—	—	—	FCANIO ⁽¹⁾	FETHIO ⁽²⁾	FMIEN ⁽²⁾
23:16	r-1	r-1	r-1	r-1	r-1	R/P	R/P	R/P
	—	—	—	—	—	FSRSSEL<2:0>		
15:8	R/P	R/P	R/P	R/P	R/P	R/P	R/P	R/P
	USERID<15:8>							
7:0	R/P	R/P	R/P	R/P	R/P	R/P	R/P	R/P
	USERID<7:0>							

Legend:

R = Readable bit	W = Writable bit	P = Programmable bit	r = Reserved bit
U = Unimplemented bit	'1' = Bit is set	'0' = Bit is cleared	x = Bit is unknown

- bit 31 **FVBUSONIO**: USB VBUS_ON Selection bit
 1 = VBUSON pin is controlled by the USB module
 0 = VBUSON pin is controlled by the port function
- bit 30 **FUSBIDIO**: USB USBID Selection bit
 1 = USBID pin is controlled by the USB module
 0 = USBID pin is controlled by the port function
- bit 29-27 **Reserved**: Write '1'
- bit 26 **FCANIO**: CAN I/O Pin Selection bit⁽¹⁾
 1 = Default CAN I/O Pins
 0 = Alternate CAN I/O Pins
- bit 25 **FETHIO**: Ethernet I/O Pin Selection bit⁽²⁾
 1 = Default Ethernet I/O Pins
 0 = Alternate Ethernet I/O Pins
- bit 24 **FMIEN**: Ethernet MII Enable bit⁽²⁾
 1 = MII is enabled
 0 = RMII is enabled
- bit 23-19 **Reserved**: Write '1'
- bit 18-16 **FSRSSEL<2:0>**: SRS Select bits
 111 = Assign Interrupt Priority 7 to a shadow register set
 110 = Assign Interrupt Priority 6 to a shadow register set
 •
 •
 •
 001 = Assign Interrupt Priority 1 to a shadow register set
 000 = All interrupt priorities are assigned to a shadow register set
- bit 15-0 **USERID<15:0>**: This is a 16-bit value that is user-defined and is readable via ICSP™ and JTAG

- Note 1:** This bit is Reserved and reads '1' on PIC32MX664/675/695 devices.
Note 2: This bit is Reserved and reads '1' on PIC32MX534/564/575 devices.

PIC32MX5XX/6XX/7XX

REGISTER 28-5: DEVID: DEVICE AND REVISION ID REGISTER

Bit Range	Bit 31/23/15/7	Bit 30/22/14/6	Bit 29/21/13/5	Bit 28/20/12/4	Bit 27/19/11/3	Bit 26/18/10/2	Bit 25/17/9/1	Bit 24/16/8/0
31:24	R	R	R	R	R	R	R	R
	VER<3:0> ⁽¹⁾				DEVID<27:24> ⁽¹⁾			
23:16	R	R	R	R	R	R	R	R
	DEVID<23:16> ⁽¹⁾							
15:8	R	R	R	R	R	R	R	R
	DEVID<15:8> ⁽¹⁾							
7:0	R	R	R	R	R	R	R	R
	DEVID<7:0> ⁽¹⁾							

Legend:

R = Readable bit

W = Writable bit

U = Unimplemented bit, read as '0'

-n = Value at POR

'1' = Bit is set

'0' = Bit is cleared

x = Bit is unknown

bit 31-28 **VER<3:0>**: Revision Identifier bits⁽¹⁾

bit 27-0 **DEVID<27:0>**: Device ID⁽¹⁾

Note 1: See the "PIC32 Flash Programming Specification" (DS61145) for a list of Revision and Device ID values.

28.2 Watchdog Timer (WDT)

This section describes the operation of the WDT and Power-up Timer of the PIC32MX5XX/6XX/7XX.

The WDT, when enabled, operates from the internal Low-Power Oscillator (LPRC) clock source and can be used to detect system software malfunctions by resetting the device if the WDT is not cleared periodically in software. Various WDT time-out periods can be selected using the WDT postscaler. The WDT can also be used to wake the device from Sleep or Idle mode.

The following are some of the key features of the WDT module:

- Configuration or software controlled
- User-configurable time-out period
- Can wake the device from Sleep or Idle

FIGURE 28-1: WATCHDOG AND POWER-UP TIMER BLOCK DIAGRAM

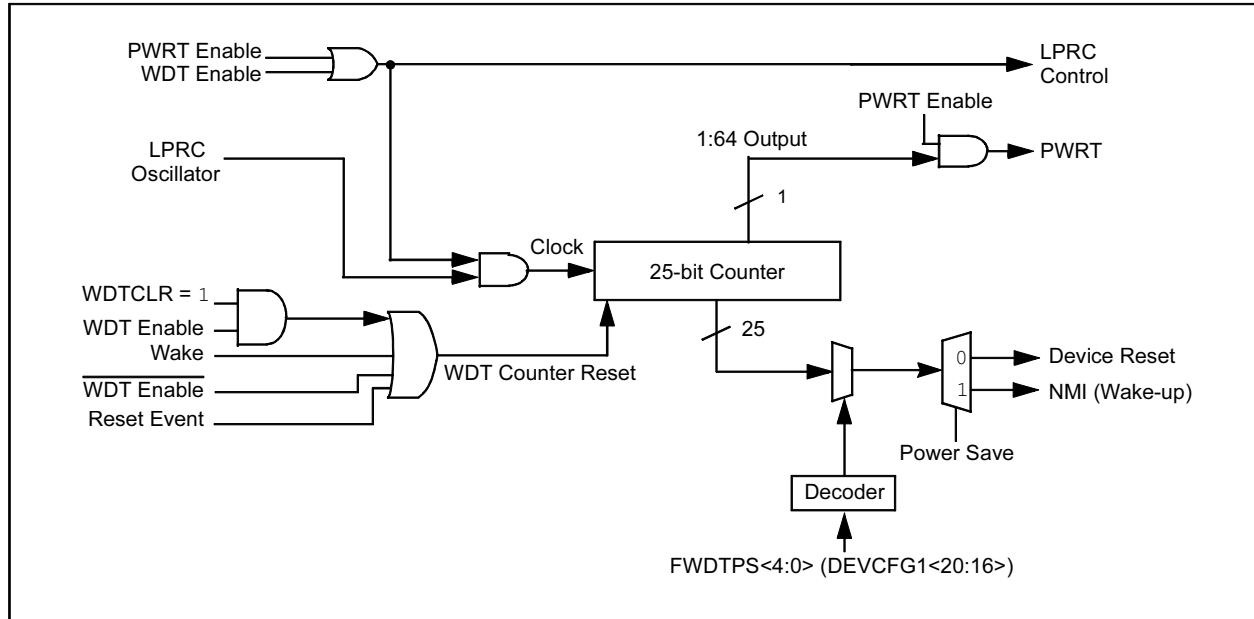

28.3 On-Chip Voltage Regulator

All PIC32MX5XX/6XX/7XX devices' core and digital logic are designed to operate at a nominal 1.8V. To simplify system designs, most devices in the PIC32MX5XX/6XX/7XX family incorporate an on-chip regulator providing the required core logic voltage from VDD.

A low-ESR capacitor (such as tantalum) must be connected to the VCAP/VCORE pin (see Figure 28-2). This helps to maintain the stability of the regulator. The recommended value for the filter capacitor is provided in Section 31.1 "DC Characteristics".

Note: It is important that the low-ESR capacitor is placed as close as possible to the VCAP/VCORE pin.

28.3.1 ON-CHIP REGULATOR AND POR

It takes a fixed delay for the on-chip regulator to generate an output. During this time, designated as TPU, code execution is disabled. TPU is applied every time the device resumes operation after any power-down, including Sleep mode.

28.3.2 ON-CHIP REGULATOR AND BOR

PIC32MX5XX/6XX/7XX devices also have a simple brown-out capability. If the voltage supplied to the regulator is inadequate to maintain a regulated level, the regulator Reset circuitry will generate a Brown-out Reset. This event is captured by the BOR flag bit (RCON<1>). The brown-out voltage levels are specified in Section 31.1 "DC Characteristics".

28.3.3 POWER-UP REQUIREMENTS

The on-chip regulator is designed to meet the power-up requirements for the device. If the application does not use the regulator, strict power-up conditions must be adhered to. While powering up, V_{CORE} must never exceed V_{DD} by 0.3V.

FIGURE 28-2: CONNECTIONS FOR THE ON-CHIP REGULATOR

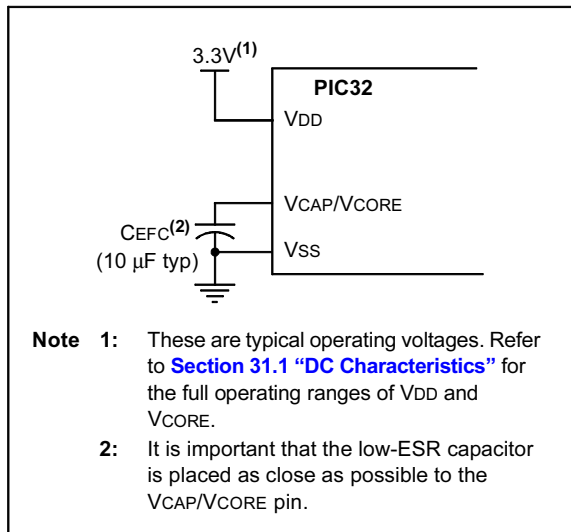

28.4 Programming and Diagnostics

PIC32MX5XX/6XX/7XX devices provide a complete range of programming and diagnostic features that can increase the flexibility of any application using them. These features allow system designers to include:

- Simplified field programmability using two-wire In-Circuit Serial Programming™ (ICSP™) interfaces
- Debugging using ICSP
- Programming and debugging capabilities using the EJTAG extension of JTAG
- JTAG boundary scan testing for device and board diagnostics

PIC32 devices incorporate two programming and diagnostic modules, and a trace controller, that provide a range of functions to the application developer.

FIGURE 28-3: BLOCK DIAGRAM OF PROGRAMMING, DEBUGGING AND TRACE PORTS

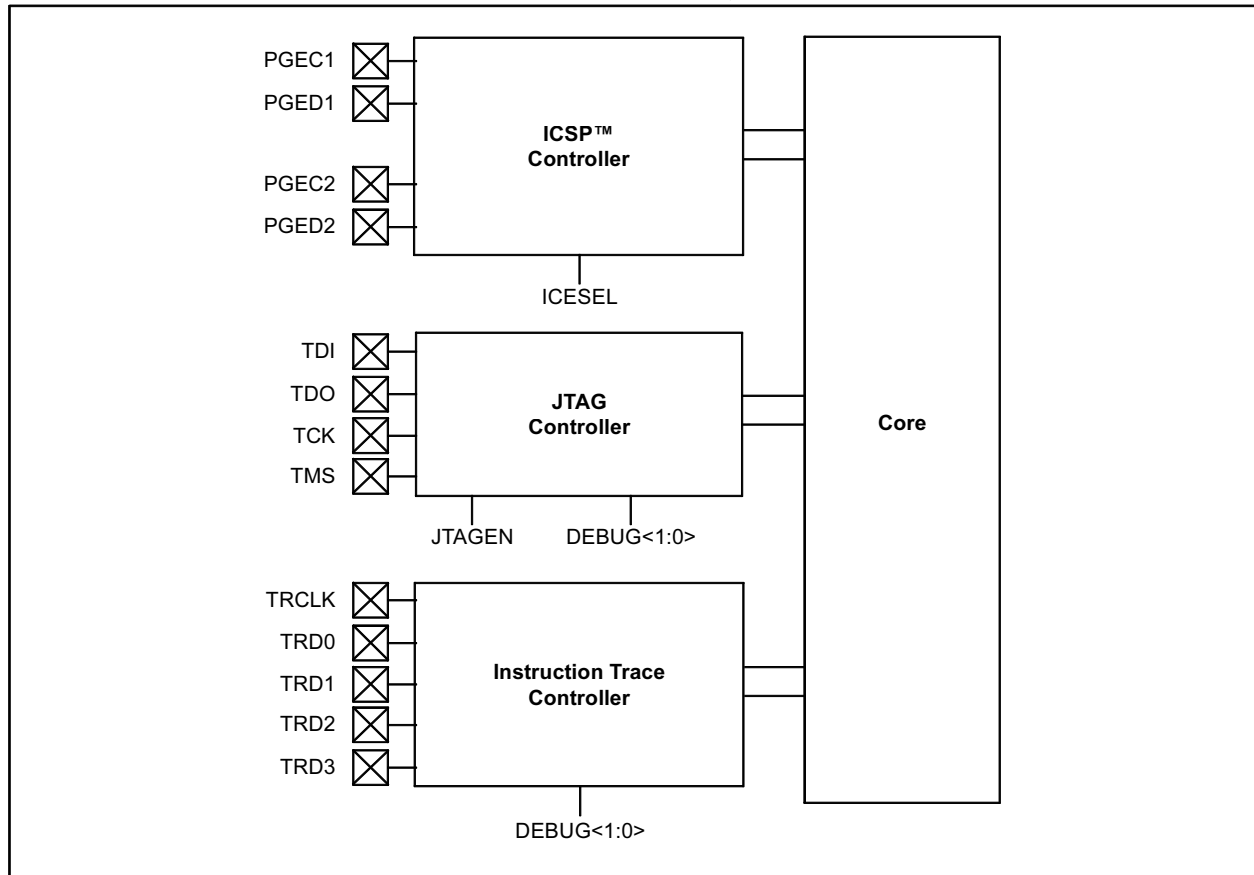

PIC32MX5XX/6XX/7XX

REGISTER 28-6: DDPCON: DEBUG DATA PORT CONTROL REGISTER

Bit Range	Bit 31/23/15/7	Bit 30/22/14/6	Bit 29/21/13/5	Bit 28/20/12/4	Bit 27/19/11/3	Bit 26/18/10/2	Bit 25/17/9/1	Bit 24/16/8/0
31:24	U-0	U-0	U-0	U-0	U-0	U-0	U-0	U-0
	—	—	—	—	—	—	—	—
23:16	U-0	U-0	U-0	U-0	U-0	U-0	U-0	U-0
	—	—	—	—	—	—	—	—
15:8	U-0	U-0	U-0	U-0	U-0	U-0	U-0	U-0
	—	—	—	—	—	—	—	—
7:0	U-0	U-0	U-0	U-0	R/W-1	R/W-0	U-0	R/W-0
	—	—	—	—	JTAGEN	TROEN	—	TDOEN

Legend:

R = Readable bit

W = Writable bit

U = Unimplemented bit, read as '0'

-n = Value at POR

'1' = Bit is set

'0' = Bit is cleared

x = Bit is unknown

bit 31-4 **Unimplemented:** Read as '0'

bit 3 **JTAGEN:** JTAG Port Enable bit

1 = Enable the JTAG port

0 = Disable the JTAG port

bit 2 **TROEN:** Trace Output Enable bit

1 = Enable the trace port

0 = Disable the trace port

bit 1 **Unimplemented:** Read as '0'

bit 0 **TDOEN:** TDO Enable for 2-Wire JTAG

1 = 2-wire JTAG protocol uses TDO

0 = 2-wire JTAG protocol does not use TDO

29.0 INSTRUCTION SET

The PIC32MX5XX/6XX/7XX family instruction set complies with the MIPS32 Release 2 instruction set architecture. The PIC32 device family does not support the following features:

- Core extend instructions
- Coprocessor 1 instructions
- Coprocessor 2 instructions

Note: Refer to “MIPS32[®] Architecture for Programmers Volume II: The MIPS32[®] Instruction Set” at www.mips.com for more information.

NOTES:

30.0 DEVELOPMENT SUPPORT

The PIC® microcontrollers and dsPIC® digital signal controllers are supported with a full range of software and hardware development tools:

- Integrated Development Environment
 - MPLAB® IDE Software
- Compilers/Assemblers/Linkers
 - MPLAB C Compiler for Various Device Families
 - HI-TECH C for Various Device Families
 - MPASM™ Assembler
 - MPLINK™ Object Linker/
MPLIB™ Object Librarian
 - MPLAB Assembler/Linker/Librarian for Various Device Families
- Simulators
 - MPLAB SIM Software Simulator
- Emulators
 - MPLAB REAL ICE™ In-Circuit Emulator
- In-Circuit Debuggers
 - MPLAB ICD 3
 - PICKit™ 3 Debug Express
- Device Programmers
 - PICKit™ 2 Programmer
 - MPLAB PM3 Device Programmer
- Low-Cost Demonstration/Development Boards, Evaluation Kits, and Starter Kits

30.1 MPLAB Integrated Development Environment Software

The MPLAB IDE software brings an ease of software development previously unseen in the 8/16/32-bit microcontroller market. The MPLAB IDE is a Windows® operating system-based application that contains:

- A single graphical interface to all debugging tools
 - Simulator
 - Programmer (sold separately)
 - In-Circuit Emulator (sold separately)
 - In-Circuit Debugger (sold separately)
- A full-featured editor with color-coded context
- A multiple project manager
- Customizable data windows with direct edit of contents
- High-level source code debugging
- Mouse over variable inspection
- Drag and drop variables from source to watch windows
- Extensive on-line help
- Integration of select third party tools, such as IAR C Compilers

The MPLAB IDE allows you to:

- Edit your source files (either C or assembly)
- One-touch compile or assemble, and download to emulator and simulator tools (automatically updates all project information)
- Debug using:
 - Source files (C or assembly)
 - Mixed C and assembly
 - Machine code

MPLAB IDE supports multiple debugging tools in a single development paradigm, from the cost-effective simulators, through low-cost in-circuit debuggers, to full-featured emulators. This eliminates the learning curve when upgrading to tools with increased flexibility and power.

30.2 MPLAB C Compilers for Various Device Families

The MPLAB C Compiler code development systems are complete ANSI C compilers for Microchip's PIC18, PIC24 and PIC32 families of microcontrollers and the dsPIC30 and dsPIC33 families of digital signal controllers. These compilers provide powerful integration capabilities, superior code optimization and ease of use.

For easy source level debugging, the compilers provide symbol information that is optimized to the MPLAB IDE debugger.

30.3 HI-TECH C for Various Device Families

The HI-TECH C Compiler code development systems are complete ANSI C compilers for Microchip's PIC family of microcontrollers and the dsPIC family of digital signal controllers. These compilers provide powerful integration capabilities, omniscient code generation and ease of use.

For easy source level debugging, the compilers provide symbol information that is optimized to the MPLAB IDE debugger.

The compilers include a macro assembler, linker, pre-processor, and one-step driver, and can run on multiple platforms.

30.4 MPASM Assembler

The MPASM Assembler is a full-featured, universal macro assembler for PIC10/12/16/18 MCUs.

The MPASM Assembler generates relocatable object files for the MPLINK Object Linker, Intel® standard HEX files, MAP files to detail memory usage and symbol reference, absolute LST files that contain source lines and generated machine code and COFF files for debugging.

The MPASM Assembler features include:

- Integration into MPLAB IDE projects
- User-defined macros to streamline assembly code
- Conditional assembly for multi-purpose source files
- Directives that allow complete control over the assembly process

30.5 MPLINK Object Linker/ MPLIB Object Librarian

The MPLINK Object Linker combines relocatable objects created by the MPASM Assembler and the MPLAB C18 C Compiler. It can link relocatable objects from precompiled libraries, using directives from a linker script.

The MPLIB Object Librarian manages the creation and modification of library files of precompiled code. When a routine from a library is called from a source file, only the modules that contain that routine will be linked in with the application. This allows large libraries to be used efficiently in many different applications.

The object linker/library features include:

- Efficient linking of single libraries instead of many smaller files
- Enhanced code maintainability by grouping related modules together
- Flexible creation of libraries with easy module listing, replacement, deletion and extraction

30.6 MPLAB Assembler, Linker and Librarian for Various Device Families

MPLAB Assembler produces relocatable machine code from symbolic assembly language for PIC24, PIC32 and dsPIC DSC devices. MPLAB C Compiler uses the assembler to produce its object file. The assembler generates relocatable object files that can then be archived or linked with other relocatable object files and archives to create an executable file. Notable features of the assembler include:

- Support for the entire device instruction set
- Support for fixed-point and floating-point data
- Command line interface
- Rich directive set
- Flexible macro language
- MPLAB IDE compatibility

30.7 MPLAB SIM Software Simulator

The MPLAB SIM Software Simulator allows code development in a PC-hosted environment by simulating the PIC MCUs and dsPIC[®] DSCs on an instruction level. On any given instruction, the data areas can be examined or modified and stimuli can be applied from a comprehensive stimulus controller. Registers can be logged to files for further run-time analysis. The trace buffer and logic analyzer display extend the power of the simulator to record and track program execution, actions on I/O, most peripherals and internal registers.

The MPLAB SIM Software Simulator fully supports symbolic debugging using the MPLAB C Compilers, and the MPASM and MPLAB Assemblers. The software simulator offers the flexibility to develop and debug code outside of the hardware laboratory environment, making it an excellent, economical software development tool.

30.8 MPLAB REAL ICE In-Circuit Emulator System

MPLAB REAL ICE In-Circuit Emulator System is Microchip's next generation high-speed emulator for Microchip Flash DSC and MCU devices. It debugs and programs PIC[®] Flash MCUs and dsPIC[®] Flash DSCs with the easy-to-use, powerful graphical user interface of the MPLAB Integrated Development Environment (IDE), included with each kit.

The emulator is connected to the design engineer's PC using a high-speed USB 2.0 interface and is connected to the target with either a connector compatible with in-circuit debugger systems (RJ11) or with the new high-speed, noise tolerant, Low-Voltage Differential Signal (LVDS) interconnection (CAT5).

The emulator is field upgradable through future firmware downloads in MPLAB IDE. In upcoming releases of MPLAB IDE, new devices will be supported, and new features will be added. MPLAB REAL ICE offers significant advantages over competitive emulators including low-cost, full-speed emulation, run-time variable watches, trace analysis, complex breakpoints, a ruggedized probe interface and long (up to three meters) interconnection cables.

30.9 MPLAB ICD 3 In-Circuit Debugger System

MPLAB ICD 3 In-Circuit Debugger System is Microchip's most cost effective high-speed hardware debugger/programmer for Microchip Flash Digital Signal Controller (DSC) and microcontroller (MCU) devices. It debugs and programs PIC[®] Flash microcontrollers and dsPIC[®] DSCs with the powerful, yet easy-to-use graphical user interface of MPLAB Integrated Development Environment (IDE).

The MPLAB ICD 3 In-Circuit Debugger probe is connected to the design engineer's PC using a high-speed USB 2.0 interface and is connected to the target with a connector compatible with the MPLAB ICD 2 or MPLAB REAL ICE systems (RJ-11). MPLAB ICD 3 supports all MPLAB ICD 2 headers.

30.10 PICkit 3 In-Circuit Debugger/Programmer and PICkit 3 Debug Express

The MPLAB PICkit 3 allows debugging and programming of PIC[®] and dsPIC[®] Flash microcontrollers at a most affordable price point using the powerful graphical user interface of the MPLAB Integrated Development Environment (IDE). The MPLAB PICkit 3 is connected to the design engineer's PC using a full speed USB interface and can be connected to the target via an Microchip debug (RJ-11) connector (compatible with MPLAB ICD 3 and MPLAB REAL ICE). The connector uses two device I/O pins and the reset line to implement in-circuit debugging and In-Circuit Serial Programming[™].

The PICkit 3 Debug Express include the PICkit 3, demo board and microcontroller, hookup cables and CDROM with user's guide, lessons, tutorial, compiler and MPLAB IDE software.

30.11 PICkit 2 Development Programmer/Debugger and PICkit 2 Debug Express

The PICkit™ 2 Development Programmer/Debugger is a low-cost development tool with an easy to use interface for programming and debugging Microchip's Flash families of microcontrollers. The full featured Windows® programming interface supports baseline (PIC10F, PIC12F5xx, PIC16F5xx), midrange (PIC12F6xx, PIC16F), PIC18F, PIC24, dsPIC30, dsPIC33, and PIC32 families of 8-bit, 16-bit, and 32-bit microcontrollers, and many Microchip Serial EEPROM products. With Microchip's powerful MPLAB Integrated Development Environment (IDE) the PICkit™ 2 enables in-circuit debugging on most PIC® microcontrollers. In-Circuit-Debugging runs, halts and single steps the program while the PIC microcontroller is embedded in the application. When halted at a breakpoint, the file registers can be examined and modified.

The PICkit 2 Debug Express include the PICkit 2, demo board and microcontroller, hookup cables and CDROM with user's guide, lessons, tutorial, compiler and MPLAB IDE software.

30.12 MPLAB PM3 Device Programmer

The MPLAB PM3 Device Programmer is a universal, CE compliant device programmer with programmable voltage verification at VDDMIN and VDDMAX for maximum reliability. It features a large LCD display (128 x 64) for menus and error messages and a modular, detachable socket assembly to support various package types. The ICSP™ cable assembly is included as a standard item. In Stand-Alone mode, the MPLAB PM3 Device Programmer can read, verify and program PIC devices without a PC connection. It can also set code protection in this mode. The MPLAB PM3 connects to the host PC via an RS-232 or USB cable. The MPLAB PM3 has high-speed communications and optimized algorithms for quick programming of large memory devices and incorporates an MMC card for file storage and data applications.

30.13 Demonstration/Development Boards, Evaluation Kits, and Starter Kits

A wide variety of demonstration, development and evaluation boards for various PIC MCUs and dsPIC DSCs allows quick application development on fully functional systems. Most boards include prototyping areas for adding custom circuitry and provide application firmware and source code for examination and modification.

The boards support a variety of features, including LEDs, temperature sensors, switches, speakers, RS-232 interfaces, LCD displays, potentiometers and additional EEPROM memory.

The demonstration and development boards can be used in teaching environments, for prototyping custom circuits and for learning about various microcontroller applications.

In addition to the PICDEM™ and dsPICDEM™ demonstration/development board series of circuits, Microchip has a line of evaluation kits and demonstration software for analog filter design, KEELOQ® security ICs, CAN, IrDA®, PowerSmart battery management, SEEVAL® evaluation system, Sigma-Delta ADC, flow rate sensing, plus many more.

Also available are starter kits that contain everything needed to experience the specified device. This usually includes a single application and debug capability, all on one board.

Check the Microchip web page (www.microchip.com) for the complete list of demonstration, development and evaluation kits.

31.0 ELECTRICAL CHARACTERISTICS

This section provides an overview of the PIC32MX5XX/6XX/7XX electrical characteristics. Additional information will be provided in future revisions of this document as it becomes available.

Absolute maximum ratings for the PIC32MX5XX/6XX/7XX devices are listed below. Exposure to these maximum rating conditions for extended periods may affect device reliability. Functional operation of the device at these or any other conditions, above the parameters indicated in the operation listings of this specification, is not implied.

Absolute Maximum Ratings

(Note 1)

Ambient temperature under bias	-40°C to +105°C
Storage temperature	-65°C to +150°C
Voltage on VDD with respect to VSS	-0.3V to +4.0V
Voltage on any pin that is not 5V tolerant, with respect to VSS (Note 3)	-0.3V to (VDD + 0.3V)
Voltage on any 5V tolerant pin with respect to VSS when VDD ≥ 2.3V (Note 3)	-0.3V to +5.5V
Voltage on any 5V tolerant pin with respect to VSS when VDD < 2.3V (Note 3)	-0.3V to +3.6V
Voltage on VBUS with respect to VSS	-0.3V to +5.5V
Voltage on VCORE with respect to VSS	-0.3V to 2.0V
Maximum current out of VSS pin(s).....	300 mA
Maximum current into VDD pin(s) (Note 2)	300 mA
Maximum output current sunk by any I/O pin.....	25 mA
Maximum output current sourced by any I/O pin	25 mA
Maximum current sunk by all ports	200 mA
Maximum current sourced by all ports (Note 2)	200 mA

Note 1: Stresses above those listed under “**Absolute Maximum Ratings**” may cause permanent damage to the device. This is a stress rating only and functional operation of the device at those or any other conditions, above those indicated in the operation listings of this specification, is not implied. Exposure to maximum rating conditions for extended periods may affect device reliability.

2: Maximum allowable current is a function of device maximum power dissipation (see [Table 31-2](#)).

3: See the “[Pin Diagrams](#)” section for the 5V tolerant pins.

PIC32MX5XX/6XX/7XX

31.1 DC Characteristics

TABLE 31-1: OPERATING MIPS VS. VOLTAGE

Characteristic	VDD Range (in Volts)	Temp. Range (in °C)	Max. Frequency
			PIC32MX5XX/6XX/7XX
DC5	2.3-3.6V	-40°C to +85°C	80 MHz
DC5b	2.3-3.6V	-40°C to +105°C	80 MHz

TABLE 31-2: THERMAL OPERATING CONDITIONS

Rating	Symbol	Min.	Typical	Max.	Unit
Industrial Temperature Devices					
Operating Junction Temperature Range	TJ	-40	—	+125	°C
Operating Ambient Temperature Range	TA	-40	—	+85	°C
V-Temp Temperature Devices					
Operating Junction Temperature Range	TJ	-40	—	+140	°C
Operating Ambient Temperature Range	TA	-40	—	+105	°C
Power Dissipation: Internal Chip Power Dissipation: PINT = VDD x (IDD – S IOH) I/O Pin Power Dissipation: I/O = S ((VDD – VOH} x IOH) + S (VOL x IOL))	PD	PINT + PI/O			W
Maximum Allowed Power Dissipation	PDMAX	(TJ – TA)/θJA			W

TABLE 31-3: THERMAL PACKAGING CHARACTERISTICS

Characteristics	Symbol	Typical	Max.	Unit	See Note
Package Thermal Resistance, 121-Pin XBGA (10x10x1.1 mm)	θJA	40	—	°C/W	1
Package Thermal Resistance, 100-Pin TQFP (14x14x1 mm)	θJA	43	—	°C/W	1
Package Thermal Resistance, 100-Pin TQFP (12x12x1 mm)	θJA	43	—	°C/W	1
Package Thermal Resistance, 64-Pin TQFP (10x10x1 mm)	θJA	47	—	°C/W	1
Package Thermal Resistance, 64-Pin QFN (9x9x0.9 mm)	θJA	28	—	°C/W	1

Note 1: Junction to ambient thermal resistance, Theta-JA (θJA) numbers are achieved by package simulations.

TABLE 31-4: DC TEMPERATURE AND VOLTAGE SPECIFICATIONS

DC CHARACTERISTICS		Standard Operating Conditions: 2.3V to 3.6V (unless otherwise stated) Operating temperature -40°C ≤TA ≤+85°C for Industrial -40°C ≤TA ≤+105°C for V-Temp					
Param. No.	Symbol	Characteristics	Min.	Typical	Max.	Units	Conditions
Operating Voltage							
DC10	VDD	Supply Voltage	2.3	—	3.6	V	—
DC12	VDR	RAM Data Retention Voltage⁽¹⁾	1.75	—	—	V	—
DC16	VPOR	VDD Start Voltage to Ensure Internal Power-on Reset Signal	1.75	—	2.1	V	—
DC17	SVDD	VDD Rise Rate to Ensure Internal Power-on Reset Signal	0.00005	—	0.115	V/μs	—

Note 1: This is the limit to which VDD can be lowered without losing RAM data.

TABLE 31-5: DC CHARACTERISTICS: OPERATING CURRENT (IDD)

DC CHARACTERISTICS			Standard Operating Conditions: 2.3V to 3.6V (unless otherwise stated) Operating temperature -40°C ≤TA ≤+85°C for Industrial -40°C ≤TA ≤+105°C for V-Temp				
Param. No.	Typical ⁽³⁾	Max.	Units	Conditions			
Operating Current (IDD)^(1,2) for PIC32MX575/675/695/775 Family Devices							
DC20	6	9	mA	Code executing from Flash	-40°C, +25°C, +85°C	—	4 MHz
DC20b	7	10			+105°C		
DC20a	4	—		Code executing from SRAM	—		
DC21	37	40	mA	Code executing from Flash	—	—	25 MHz (Note 4)
DC21a	25	—		Code executing from SRAM			
DC22	64	70	mA	Code executing from Flash	—	—	60 MHz (Note 4)
DC22a	61	—		Code executing from SRAM			
DC23	85	98	mA	Code executing from Flash	-40°C, +25°C, +85°C	—	80 MHz
DC23b	90	120			+105°C		
DC23a	85	—		Code executing from SRAM	—		
DC25a	125	150	μA	—	+25°C	3.3V	LPRC (31 kHz) (Note 4)
Operating Current (IDD)^(1,2,5) for PIC32MX534/564/664/764 Family Devices							
DC20b	6	9	mA	Code executing from Flash	—	—	4 MHz
DC20c	2	—	mA	Code executing from SRAM	—	—	
DC21b	19	40	mA	Code executing from Flash	—	—	25 MHz (Note 4)
DC21c	14	—	mA	Code executing from SRAM	—	—	
DC22b	31	70	mA	Code executing from Flash	—	—	60 MHz (Note 4)
DC22c	29	—	mA	Code executing from SRAM	—	—	
DC23b	39	98	mA	Code executing from Flash	—	—	80 MHz
DC23c	39	—	mA	Code executing from SRAM	—	—	
DC25b	100	150	μA	—	+25°C	3.3V	LPRC (31 kHz) (Note 4)

- Note 1:** A device's IDD supply current is mainly a function of the operating voltage and frequency. Other factors, such as PBCLK (Peripheral Bus Clock) frequency, number of peripheral modules enabled, internal code execution pattern, execution from Program Flash memory vs. SRAM, I/O pin loading and switching rate, oscillator type, as well as temperature, can have an impact on the current consumption.
- 2:** The test conditions for IDD measurements are as follows: Oscillator mode = EC+PLL with OSC1 driven by external square wave from rail-to-rail and PBCLK divisor = 1:8. CPU, Program Flash and SRAM data memory are operational, program Flash memory Wait states = 7, program cache and prefetch are disabled and SRAM data memory Wait states = 1. All peripheral modules are disabled (ON bit = 0). WDT and FSCM are disabled. All I/O pins are configured as inputs and pulled to Vss. MCLR = VDD.
- 3:** Data in "Typical" column is at 3.3V, 25°C at specified operating frequency unless otherwise stated. Parameters are for design guidance only and are not tested.
- 4:** This parameter is characterized, but not tested in manufacturing.
- 5:** This information is preliminary.

PIC32MX5XX/6XX/7XX

TABLE 31-6: DC CHARACTERISTICS: IDLE CURRENT (IDLE)

DC CHARACTERISTICS			Standard Operating Conditions: 2.3V to 3.6V (unless otherwise stated) Operating temperature -40°C ≤TA ≤+85°C for Industrial -40°C ≤TA ≤+105°C for V-Temp			
Parameter No.	Typical ⁽²⁾	Max.	Units	Conditions		
Idle Current (IDLE): Core Off, Clock on Base Current⁽¹⁾ for PIC32MX575/675/695/775 Family Devices						
DC30	4.5	6.5	mA	-40°C, +25°C, +85°C	—	4 MHz
DC30b	5	7	mA	+105°C		
DC31	13	15	mA	-40°C, +25°C, +85°C	—	25 MHz (Note 3)
DC32	28	30	mA	-40°C, +25°C, +85°C	—	60 MHz (Note 3)
DC33	36	42	mA	-40°C, +25°C, +85°C	—	80 MHz
DC33b	39	45	mA	+105°C		
DC34	—	40	μA	-40°C	2.3V	LPRC (31 kHz) (Note 3)
DC34a	—	75	μA	+25°C		
DC34b	—	800	μA	+85°C		
DC34c	—	1000	μA	+105°C		
DC35	35	—	μA	-40°C	3.3V	
DC35a	65	—	μA	+25°C		
DC35b	600	—	μA	+85°C		
DC35c	800	—	μA	+105°C		
DC36	—	43	μA	-40°C	3.6V	
DC36a	—	106	μA	+25°C		
DC36b	—	800	μA	+85°C		
DC36c	—	1000	μA	+105°C		
Idle Current (IDLE): Core Off, Clock on Base Current^(1,4) for PIC32MX534/564/664/764 Family Devices						
DC30a	1.5	6.5	mA	-40°C, +25°C, +85°C	—	4 MHz
DC31a	7	15	mA	-40°C, +25°C, +85°C	—	25 MHz (Note 3)
DC32a	13	30	mA	-40°C, +25°C, +85°C	—	60 MHz (Note 3)
DC33a	17	42	mA	-40°C, +25°C, +85°C	—	80 MHz
DC34c	—	40	μA	-40°C	2.3V	LPRC (31 kHz) (Note 3)
DC34d	—	75	μA	+25°C		
DC34e	—	800	μA	+85°C		
DC35c	30	—	μA	-40°C	3.3V	
DC35d	55	—	μA	+25°C		
DC35e	230	—	μA	+85°C		
DC36c	—	43	μA	-40°C	3.6V	
DC36d	—	106	μA	+25°C		
DC36e	—	800	μA	+85°C		

Note 1: The test conditions for base IDLE current measurements are as follows: System clock is enabled and PBCLK divisor = 1:8. CPU in Idle mode (CPU core Halted). Only digital peripheral modules are enabled (ON bit = 1) and being clocked. WDT and FSCM are disabled. All I/O pins are configured as inputs and pulled to VSS. MCLR = VDD.

2: Data in "Typical" column is at 3.3V, 25°C unless otherwise stated. Parameters are for design guidance only and are not tested.

3: This parameter is characterized, but not tested in manufacturing.

4: This information is preliminary.

TABLE 31-7: DC CHARACTERISTICS: POWER-DOWN CURRENT (IPD)

DC CHARACTERISTICS			Standard Operating Conditions: 2.3V to 3.6V (unless otherwise stated) Operating temperature $-40^{\circ}\text{C} \leq T_A \leq +85^{\circ}\text{C}$ for Industrial $-40^{\circ}\text{C} \leq T_A \leq +105^{\circ}\text{C}$ for V-Temp		
Param. No.	Typical ⁽²⁾	Max.	Units	Conditions	
Power-Down Current (IPD)⁽¹⁾ for PIC32MX575/675/695/775 Family Devices					
DC40	10	40	μA	-40°C	2.3V Base Power-Down Current (Note 6)
DC40a	36	100	μA	$+25^{\circ}\text{C}$	
DC40b	400	720	μA	$+85^{\circ}\text{C}$	
DC40h	900	1800	μA	$+105^{\circ}\text{C}$	
DC40c	41	120	μA	$+25^{\circ}\text{C}$	3.3V Base Power-Down Current
DC40d	22	80	μA	-40°C	3.6V Base Power-Down Current
DC40e	42	120	μA	$+25^{\circ}\text{C}$	
DC40g	315	400 ⁽⁵⁾	μA	$+70^{\circ}\text{C}$	
DC40f	410	800	μA	$+85^{\circ}\text{C}$	
DC40i	1000	2000	μA	$+105^{\circ}\text{C}$	
Module Differential Current for PIC32MX575/675/695/775 Family Devices					
DC41	—	10	μA	—	2.3V Watchdog Timer Current: ΔI_{WDT} (Notes 3,6)
DC41a	5	—	μA	—	3.3V Watchdog Timer Current: ΔI_{WDT} (Note 3)
DC41b	—	20	μA	—	3.6V Watchdog Timer Current: ΔI_{WDT} (Note 3)
DC42	—	40	μA	—	2.3V RTCC + Timer1 w/32 kHz Crystal: ΔI_{RTCC} (Notes 3,6)
DC42a	23	—	μA	—	3.3V RTCC + Timer1 w/32 kHz Crystal: ΔI_{RTCC} (Note 3)
DC42b	—	50	μA	—	3.6V RTCC + Timer1 w/32 kHz Crystal: ΔI_{RTCC} (Note 3)
DC43	—	1300	μA	—	2.5V ADC: ΔI_{ADC} (Notes 3,4,6)
DC43a	1100	—	μA	—	3.3V ADC: ΔI_{ADC} (Notes 3,4)
DC43b	—	1300	μA	—	3.6V ADC: ΔI_{ADC} (Notes 3,4)
Power-Down Current (IPD)^(1,7) for PIC32MX534/564/664/764 Family Devices					
DC40g	12	40	μA	-40°C	2.3V Base Power-Down Current (Note 6)
DC40h	20	100	μA	$+25^{\circ}\text{C}$	
DC40i	210	720	μA	$+85^{\circ}\text{C}$	
DC40j	20	120	μA	$+25^{\circ}\text{C}$	3.3V Base Power-Down Current
DC40k	15	80	μA	-40°C	3.6V Base Power-Down Current
DC40l	20	120	μA	$+25^{\circ}\text{C}$	
DC40m	113	400 ⁽⁵⁾	μA	$+70^{\circ}\text{C}$	
DC40n	210	800	μA	$+85^{\circ}\text{C}$	

Note 1: Base IPD is measured with all digital peripheral modules and being clocked, CPU clock is disabled. All I/Os are configured as inputs and pulled low. WDT and FSCM are disabled.

2: Data in the "Typical" column is at 3.3V, 25°C unless otherwise stated. Parameters are for design guidance only and are not tested.

3: The Δ current is the additional current consumed when the module is enabled. This current should be added to the base IPD current.

4: Test conditions for ADC module differential current are as follows: Internal ADC RC oscillator enabled.

5: Data is characterized at +70°C and not tested. Parameter is for design guidance only.

6: This parameter is characterized, but not tested in manufacturing.

7: This information is preliminary.

PIC32MX5XX/6XX/7XX

TABLE 31-7: DC CHARACTERISTICS: POWER-DOWN CURRENT (IPD) (CONTINUED)

DC CHARACTERISTICS			Standard Operating Conditions: 2.3V to 3.6V (unless otherwise stated) Operating temperature -40°C ≤TA ≤+85°C for Industrial -40°C ≤TA ≤+105°C for V-Temp			
Param. No.	Typical ⁽²⁾	Max.	Units	Conditions		
Module Differential Current⁽⁷⁾ for PIC32MX534/564/664/764 Family Devices						
DC41c	—	10	μA	—	2.5V	Watchdog Timer Current: ΔIWDT (Notes 3,6)
DC41d	5	—	μA	—	3.3V	Watchdog Timer Current: ΔIWDT (Note 3)
DC41e	—	20	μA	—	3.6V	Watchdog Timer Current: ΔIWDT (Note 3)
DC42c	—	40	μA	—	2.5V	RTCC + Timer1 w/32 kHz Crystal: ΔIRTCC (Notes 3,6)
DC42d	23	—	μA	—	3.3V	RTCC + Timer1 w/32 kHz Crystal: ΔIRTCC (Note 3)
DC42e	—	50	μA	—	3.6V	RTCC + Timer1 w/32 kHz Crystal: ΔIRTCC (Note 3)
DC43c	—	1300	μA	—	2.5V	ADC: ΔIADC (Notes 3,4,6)
DC43d	1100	—	μA	—	3.3V	ADC: ΔIADC (Notes 3,4)
DC43e	—	1300	μA	—	3.6V	ADC: ΔIADC (Notes 3,4)

- Note 1:** Base IPD is measured with all digital peripheral modules and being clocked, CPU clock is disabled. All I/Os are configured as inputs and pulled low. WDT and FSCM are disabled.
- 2:** Data in the "Typical" column is at 3.3V, 25°C unless otherwise stated. Parameters are for design guidance only and are not tested.
- 3:** The Δ current is the additional current consumed when the module is enabled. This current should be added to the base IPD current.
- 4:** Test conditions for ADC module differential current are as follows: Internal ADC RC oscillator enabled.
- 5:** Data is characterized at +70°C and not tested. Parameter is for design guidance only.
- 6:** This parameter is characterized, but not tested in manufacturing.
- 7:** This information is preliminary.

TABLE 31-8: DC CHARACTERISTICS: I/O PIN INPUT SPECIFICATIONS

DC CHARACTERISTICS			Standard Operating Conditions: 2.3V to 3.6V (unless otherwise stated) Operating temperature -40°C ≤TA ≤+85°C for Industrial -40°C ≤TA ≤+105°C for V-Temp				
Param. No.	Symbol	Characteristics	Min.	Typical ⁽¹⁾	Max.	Units	Conditions
DI10 DI15 DI16 DI17 DI18 DI19	VIL	Input Low Voltage					
		I/O Pins:					
		with TTL Buffer	VSS	—	0.15 VDD	V	
		with Schmitt Trigger Buffer	VSS	—	0.2 VDD	V	
		$\overline{\text{MCLR}}^{(2)}$	VSS	—	0.2 VDD	V	
		OSC1 (XT mode)	VSS	—	0.2 VDD	V	(Note 4)
		OSC1 (HS mode)	VSS	—	0.2 VDD	V	(Note 4)
SDAx, SCLx	VSS	—	0.3 VDD	V	SMBus disabled (Note 4)		
SDAx, SCLx	VSS	—	0.8	V	SMBus enabled (Note 4)		
DI20 DI25 DI26 DI27 DI28 DI29	VIH	Input High Voltage					
		I/O Pins:					
		with Analog Functions	0.8 VDD	—	VDD	V	(Note 4)
		Digital Only	0.8 VDD	—		V	
		with TTL Buffer	0.25 VDD + 0.8V	—	5.5	V	(Note 4)
		with Schmitt Trigger Buffer	0.8 VDD	—	5.5	V	
		$\overline{\text{MCLR}}^{(2)}$	0.8 VDD	—	VDD	V	
		OSC1 (XT mode)	0.7 VDD	—	VDD	V	(Note 4)
		OSC1 (HS mode)	0.7 VDD	—	VDD	V	(Note 4)
		SDAx, SCLx	0.7 VDD	—	5.5	V	SMBus disabled (Note 4)
SDAx, SCLx	2.1	—	5.5	V	SMBus enabled, 2.3V ≤VPIN ≤5.5 (Note 4)		
DI30	ICNPU	CNxx Pull up Current	50	250	400	μA	VDD = 3.3V, VPIN = VSS
DI50 DI51 DI55 DI56	IIL	Input Leakage Current⁽³⁾					
		I/O Ports	—	—	±1	μA	VSS ≤VPIN ≤VDD, Pin at high-impedance
		Analog Input Pins	—	—	±1	μA	VSS ≤VPIN ≤VDD, Pin at high-impedance
		$\overline{\text{MCLR}}^{(2)}$	—	—	±1	μA	VSS ≤VPIN ≤VDD
		OSC1	—	—	±1	μA	VSS ≤VPIN ≤VDD, XT and HS modes

Note 1: Data in "Typical" column is at 3.3V, 25°C unless otherwise stated. Parameters are for design guidance only and are not tested.

2: The leakage current on the $\overline{\text{MCLR}}$ pin is strongly dependent on the applied voltage level. The specified levels represent normal operating conditions. Higher leakage current may be measured at different input voltages.

3: Negative current is defined as current sourced by the pin.

4: This parameter is characterized, but not tested in manufacturing.

TABLE 31-9: DC CHARACTERISTICS: I/O PIN OUTPUT SPECIFICATIONS

DC CHARACTERISTICS			Standard Operating Conditions: 2.3V to 3.6V (unless otherwise stated) Operating temperature -40°C ≤TA ≤+85°C for Industrial -40°C ≤TA ≤+105°C for V-Temp				
Param. No.	Symbol	Characteristics	Min.	Typical	Max.	Units	Conditions
DO10	VOL	Output Low Voltage I/O Ports	—	—	0.4	V	IOL = 7 mA, VDD = 3.6V
			—	—	0.4	V	IOL = 6 mA, VDD = 2.3V
DO16		OSC2/CLKO	—	—	0.4	V	IOL = 3.5 mA, VDD = 3.6V
			—	—	0.4	V	IOL = 2.5 mA, VDD = 2.3V
DO20	VOH	Output High Voltage I/O Ports	2.4	—	—	V	IOH = -12 mA, VDD = 3.6V
			1.4	—	—	V	IOH = -12 mA, VDD = 2.3V
DO26		OSC2/CLKO	2.4	—	—	V	IOH = -12 mA, VDD = 3.6V
			1.4	—	—	V	IOH = -12 mA, VDD = 2.3V

TABLE 31-10: ELECTRICAL CHARACTERISTICS: BOR

DC CHARACTERISTICS			Standard Operating Conditions: 2.3V to 3.6V (unless otherwise stated) Operating temperature -40°C ≤TA ≤+85°C for Industrial -40°C ≤TA ≤+105°C for V-Temp				
Param. No.	Symbol	Characteristics	Min. ⁽¹⁾	Typical	Max.	Units	Conditions
BO10	VBOR	BOR Event on VDD transition high-to-low	2.0	—	2.3	V	—

Note 1: Parameters are for design guidance only and are not tested in manufacturing.

TABLE 31-11: DC CHARACTERISTICS: PROGRAM MEMORY⁽³⁾

DC CHARACTERISTICS			Standard Operating Conditions: 2.3V to 3.6V (unless otherwise stated) Operating temperature -40°C ≤T _A ≤+85°C for Industrial -40°C ≤T _A ≤+105°C for V-Temp				
Param. No.	Symbol	Characteristics	Min.	Typical ⁽¹⁾	Max.	Units	Conditions
Program Flash Memory							
D130	EP	Cell Endurance	1000	—	—	E/W	—
D130a	EP	Cell Endurance	20,000	—	—	E/W	See Note 4
D131	VPR	V _{DD} for Read	2.3	—	3.6	V	—
D132	VPEW	V _{DD} for Erase or Write	3.0	—	3.6	V	—
D132a	VPEW	V _{DD} for Erase or Write	2.3	—	3.6	V	See Note 4
D134	TRETD	Characteristic Retention	20	—	—	Year	Provided no other specifications are violated
D135	IDDP	Supply Current during Programming	—	10	—	mA	—
	TWW	Word Write Cycle Time	20	—	40	μs	—
D136	TRW	Row Write Cycle Time ⁽²⁾ (128 words per row)	3	4.5	—	ms	—
D137	TPE	Page Erase Cycle Time	20	—	—	ms	—
	TCE	Chip Erase Cycle Time	80	—	—	ms	—

Note 1: Data in “Typical” column is at 3.3V, 25°C unless otherwise stated.

2: The minimum SYSCLK for row programming is 4 MHz. Care should be taken to minimize bus activities during row programming, such as suspending any memory-to-memory DMA operations. If heavy bus loads are expected, selecting Bus Matrix Arbitration mode 2 (rotating priority) may be necessary. The default Arbitration mode is mode 1 (CPU has lowest priority).

3: Refer to “PIC32 Flash Programming Specification” (DS61145) for operating conditions during programming and erase cycles.

4: This parameter applies to PIC32MX534/564/664/764 devices only. This information is preliminary.

TABLE 31-12: PROGRAM FLASH MEMORY WAIT STATE CHARACTERISTICS

DC CHARACTERISTICS		Standard Operating Conditions: 2.3V to 3.6V (unless otherwise stated) Operating temperature -40°C ≤TA ≤+85°C for Industrial -40°C ≤TA ≤+105°C for V-Temp	
Required Flash Wait States	SYSCLK	Units	Comments
0 Wait State	0 to 30	MHz	—
1 Wait State	31 to 60		
2 Wait States	61 to 80		

TABLE 31-13: COMPARATOR SPECIFICATIONS

DC CHARACTERISTICS			Standard Operating Conditions: 2.3V to 3.6V (unless otherwise stated) Operating temperature -40°C ≤TA ≤+85°C for Industrial -40°C ≤TA ≤+105°C for V-Temp				
Param. No.	Symbol	Characteristics	Min.	Typical	Max.	Units	Comments
D300	VIOFF	Input Offset Voltage	—	±7.5	±25	mV	AVDD = VDD, AVSS = VSS
D301	VICM	Input Common Mode Voltage	0	—	VDD	V	AVDD = VDD, AVSS = VSS (Note 2)
D302	CMRR	Common Mode Rejection Ratio	55	—	—	dB	Max VICM = (VDD - 1)V (Note 2)
D303	TRESP	Response Time	—	150	400	ns	AVDD = VDD, AVSS = VSS (Notes 1, 2)
D304	ON2OV	Comparator Enabled to Output Valid	—	—	10	μs	Comparator module is configured before setting the comparator ON bit (Note 2)
D305	IVREF	Internal Voltage Reference	0.57	0.6	0.63	V	For devices without BGSEL<1:0>
			1.14	1.2	1.26	V	BGSEL<1:0> = 00
			0.57	0.6	0.63	V	BGSEL<1:0> = 01

Note 1: Response time measured with one comparator input at $(VDD - 1.5)/2$, while the other input transitions from VSS to VDD.

2: These parameters are characterized but not tested.

TABLE 31-14: VOLTAGE REFERENCE SPECIFICATIONS

DC CHARACTERISTICS			Standard Operating Conditions: 2.3V to 3.6V (unless otherwise stated) Operating temperature -40°C ≤TA ≤+85°C for Industrial -40°C ≤TA ≤+105°C for V-Temp				
Param. No.	Symbol	Characteristics	Min.	Typical	Max.	Units	Comments
D310	VRES	Resolution	VDD/24	—	VDD/32	LSb	—
D311	VRAA	Absolute Accuracy	—	—	1/2	LSb	—
D312	TSET	Settling Time ⁽¹⁾	—	—	10	μs	—
D313	VIREF	Internal Voltage Reference	—	0.6	—	V	—

Note 1: Settling time measured while CVRR = 1 and CVR<3:0> transitions from '0000' to '1111'. This parameter is characterized, but not tested in manufacturing.

TABLE 31-15: INTERNAL VOLTAGE REGULATOR SPECIFICATIONS

DC CHARACTERISTICS			Standard Operating Conditions: 2.3V to 3.6V (unless otherwise stated) Operating temperature -40°C ≤TA ≤+85°C for Industrial -40°C ≤TA ≤+105°C for V-Temp				
Param. No.	Symbol	Characteristics	Min.	Typical	Max.	Units	Comments
D320	VCORE	Regulator Output Voltage	1.62	1.80	1.98	V	—
D321	CEFC	External Filter Capacitor Value	8	10	—	μF	Capacitor must be low series resistance (1 ohm)
D322	TPWRT	Power-up Timer Period	—	64	—	ms	—

31.2 AC Characteristics and Timing Parameters

The information contained in this section defines PIC32MX5XX/6XX/7XX AC characteristics and timing parameters.

FIGURE 31-1: LOAD CONDITIONS FOR DEVICE TIMING SPECIFICATIONS

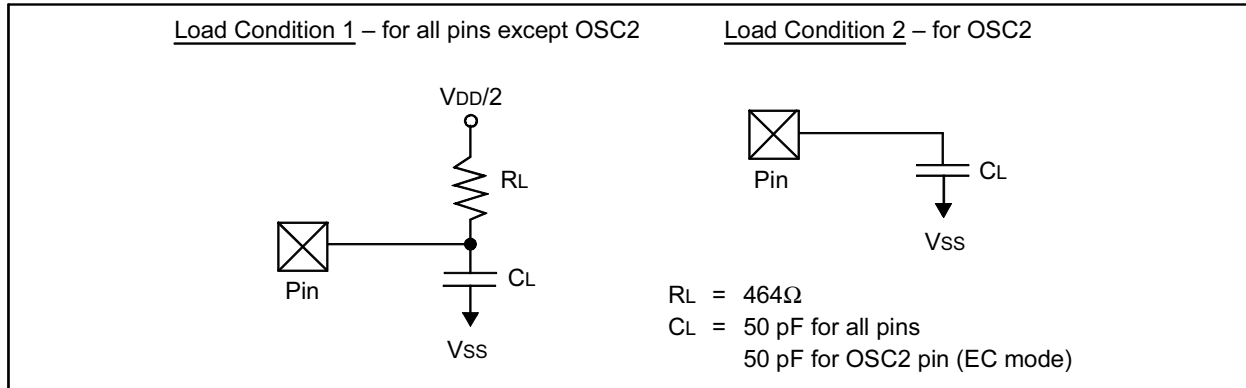

TABLE 31-16: CAPACITIVE LOADING REQUIREMENTS ON OUTPUT PINS

AC CHARACTERISTICS			Standard Operating Conditions: 2.3V to 3.6V (unless otherwise stated) Operating temperature $-40^\circ\text{C} \leq T_A \leq +85^\circ\text{C}$ for Industrial $-40^\circ\text{C} \leq T_A \leq +105^\circ\text{C}$ for V-Temp				
Param. No.	Symbol	Characteristics	Min.	Typical ⁽¹⁾	Max.	Units	Conditions
DO56	CIO	All I/O pins and OSC2	—	—	50	pF	EC mode
DO58	CB	SCLx, SDAx	—	—	400	pF	In I ² C™ mode

Note 1: Data in "Typical" column is at 3.3V, 25°C unless otherwise stated. Parameters are for design guidance only and are not tested.

FIGURE 31-2: EXTERNAL CLOCK TIMING

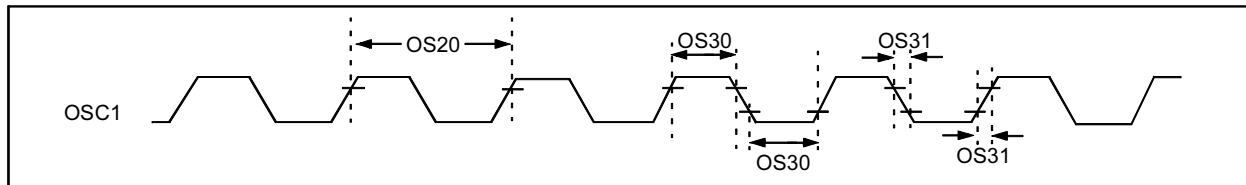

TABLE 31-17: EXTERNAL CLOCK TIMING REQUIREMENTS

AC CHARACTERISTICS			Standard Operating Conditions: 2.3V to 3.6V (unless otherwise stated) Operating temperature -40°C ≤TA ≤+85°C for Industrial -40°C ≤TA ≤+105°C for V-Temp				
Param. No.	Symbol	Characteristics	Min.	Typical ⁽¹⁾	Max.	Units	Conditions
OS10	Fosc	External CLKI Frequency (External clocks allowed only in EC and ECPLL modes)	DC	—	50	MHz	EC (Note 4) ECPLL (Note 3)
			4	—	50	MHz	
OS11		Oscillator Crystal Frequency	3	—	10	MHz	XT (Note 4)
OS12			4	—	10	MHz	XTPLL (Notes 3,4)
OS13			10	—	25	MHz	HS (Note 5)
OS14			10	—	25	MHz	HSPLL (Notes 3,4)
OS15	32		32.768	100	kHz	Sosc (Note 4)	
OS20	Tosc	Tosc = 1/Fosc = Tcy ⁽²⁾	—	—	—	—	See parameter OS10 for Fosc value
OS30	TosL, TosH	External Clock In (OSC1) High or Low Time	0.45 x Tosc	—	—	ns	EC (Note 4)
OS31	TosR, TosF	External Clock In (OSC1) Rise or Fall Time	—	—	0.05 x Tosc	ns	EC (Note 4)
OS40	TOST	Oscillator Start-up Timer Period (Only applies to HS, HSPLL, XT, XTPLL and Sosc Clock Oscillator modes)	—	1024	—	Tosc	(Note 4)
OS41	TFSCM	Primary Clock Fail Safe Time-out Period	—	2	—	ms	(Note 4)
OS42	GM	External Oscillator Transconductance	—	12	—	mA/V	VDD = 3.3V, TA = +25°C (Note 4)

- Note 1:** Data in "Typical" column is at 3.3V, 25°C unless otherwise stated. Parameters are characterized but are not tested.
- 2:** Instruction cycle period (Tcy) equals the input oscillator time base period. All specified values are based on characterization data for that particular oscillator type under standard operating conditions with the device executing code. Exceeding these specified limits may result in an unstable oscillator operation and/or higher than expected current consumption. All devices are tested to operate at "min." values with an external clock applied to the OSC1/CLKI pin.
- 3:** PLL input requirements: 4 MHz ≤ FPLLIN ≤ 5 MHz (use PLL prescaler to reduce Fosc). This parameter is characterized, but tested at 10 MHz only at manufacturing.
- 4:** This parameter is characterized, but not tested in manufacturing.

PIC32MX5XX/6XX/7XX

TABLE 31-18: PLL CLOCK TIMING SPECIFICATIONS (V_{DD} = 2.3V TO 3.6V)

AC CHARACTERISTICS		Standard Operating Conditions: 2.3V to 3.6V (unless otherwise stated) Operating temperature -40°C ≤ T _A ≤ +85°C for Industrial -40°C ≤ T _A ≤ +105°C for V-Temp					
Param. No.	Symbol	Characteristics ⁽¹⁾	Min.	Typical	Max.	Units	Conditions
OS50	FPLLI	PLL Voltage Controlled Oscillator (VCO) Input Frequency Range	4	—	5	MHz	ECPLL, HSPLL, XTPLL, FRCPLL modes
OS51	FSYS	On-Chip VCO System Frequency	60	—	120	MHz	—
OS52	TLOCK	PLL Start-up Time (Lock Time)	—	—	2	ms	—
OS53	DCLK	CLKO Stability ⁽²⁾ (Period Jitter or Cumulative)	-0.25	—	+0.25	%	Measured over 100 ms period

Note 1: These parameters are characterized, but not tested in manufacturing.

2: This jitter specification is based on clock-cycle by clock-cycle measurements. To get the effective jitter for individual time-bases on communication clocks, use the following formula:

$$EffectiveJitter = \frac{D_{CLK}}{\sqrt{\frac{SYSCLK}{CommunicationClock}}}$$

For example, if SYSCLK = 80 MHz and SPI bit rate = 20 MHz, the effective jitter is as follows:

$$EffectiveJitter = \frac{D_{CLK}}{\sqrt{\frac{80}{20}}} = \frac{D_{CLK}}{2}$$

TABLE 31-19: INTERNAL FRC ACCURACY

AC CHARACTERISTICS		Standard Operating Conditions: 2.3V to 3.6V (unless otherwise stated) Operating temperature -40°C ≤ T _A ≤ +85°C for Industrial -40°C ≤ T _A ≤ +105°C for V-Temp				
Param. No.	Characteristics	Min.	Typical	Max.	Units	Conditions
Internal FRC Accuracy @ 8.00 MHz⁽¹⁾ for PIC32MX575/675/695/775 Family Devices						
F20a	FRC	-2	—	+2	%	—
Internal FRC Accuracy @ 8.00 MHz^(1,2) for PIC32MX534/564/664/764 Family Devices						
F20b	FRC	-0.9	—	+0.9	%	—

Note 1: Frequency calibrated at 25°C and 3.3V. The TUN bits can be used to compensate for temperature drift.

2: This information is preliminary.

TABLE 31-20: INTERNAL RC ACCURACY

AC CHARACTERISTICS		Standard Operating Conditions: 2.3V to 3.6V (unless otherwise stated) Operating temperature -40°C ≤TA ≤+85°C for Industrial -40°C ≤TA ≤+105°C for V-Temp				
Param. No.	Characteristics	Min.	Typical	Max.	Units	Conditions
LPRC @ 31.25 kHz⁽¹⁾						
F21	LPRC	-15	—	+15	%	—

Note 1: Change of LPRC frequency as VDD changes.

FIGURE 31-3: I/O TIMING CHARACTERISTICS

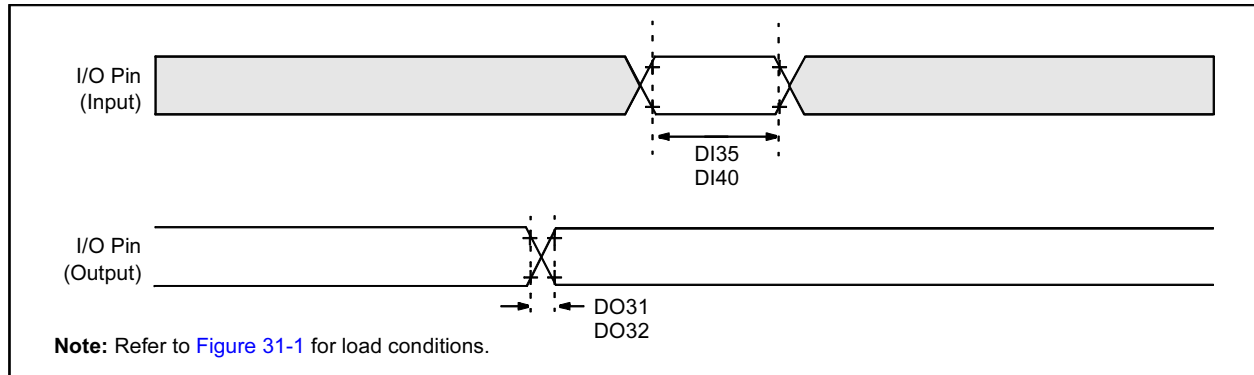

TABLE 31-21: I/O TIMING REQUIREMENTS

AC CHARACTERISTICS		Standard Operating Conditions: 2.3V to 3.6V (unless otherwise stated) Operating temperature -40°C ≤TA ≤+85°C for Industrial -40°C ≤TA ≤+105°C for V-Temp					
Param. No.	Symbol	Characteristics ⁽²⁾	Min.	Typical ⁽¹⁾	Max.	Units	Conditions
DO31	TioR	Port Output Rise Time	—	5	15	ns	VDD < 2.5V
			—	5	10	ns	VDD > 2.5V
DO32	TioF	Port Output Fall Time	—	5	15	ns	VDD < 2.5V
			—	5	10	ns	VDD > 2.5V
DI35	TINP	INTx Pin High or Low Time	10	—	—	ns	—
DI40	TRBP	CNx High or Low Time (input)	2	—	—	TSYSCLK	—

Note 1: Data in “Typical” column is at 3.3V, 25°C unless otherwise stated.

2: This parameter is characterized, but not tested in manufacturing.

FIGURE 31-4: POWER-ON RESET TIMING CHARACTERISTICS

Internal Voltage Regulator Enabled

Clock Sources = (FRC, FRCDIV, FRCDIV16, FRCPLL, EC, ECPLL and LPRC)

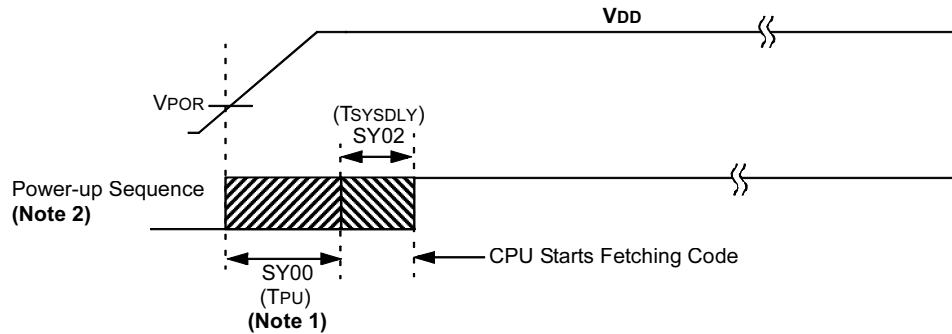

Internal Voltage Regulator Enabled

Clock Sources = (HS, HSPLL, XT, XTPLL and Sosc)

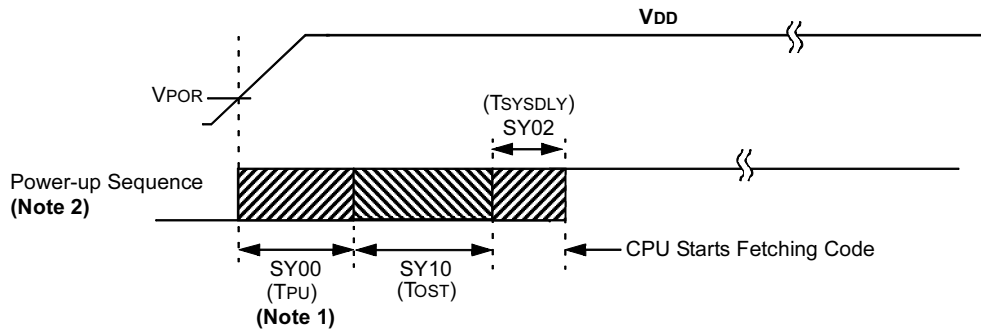

Note 1: The power-up period will be extended if the power-up sequence completes before the device exits from BOR ($V_{DD} < V_{DDMIN}$).

Note 2: Includes interval voltage regulator stabilization delay.

FIGURE 31-5: EXTERNAL RESET TIMING CHARACTERISTICS

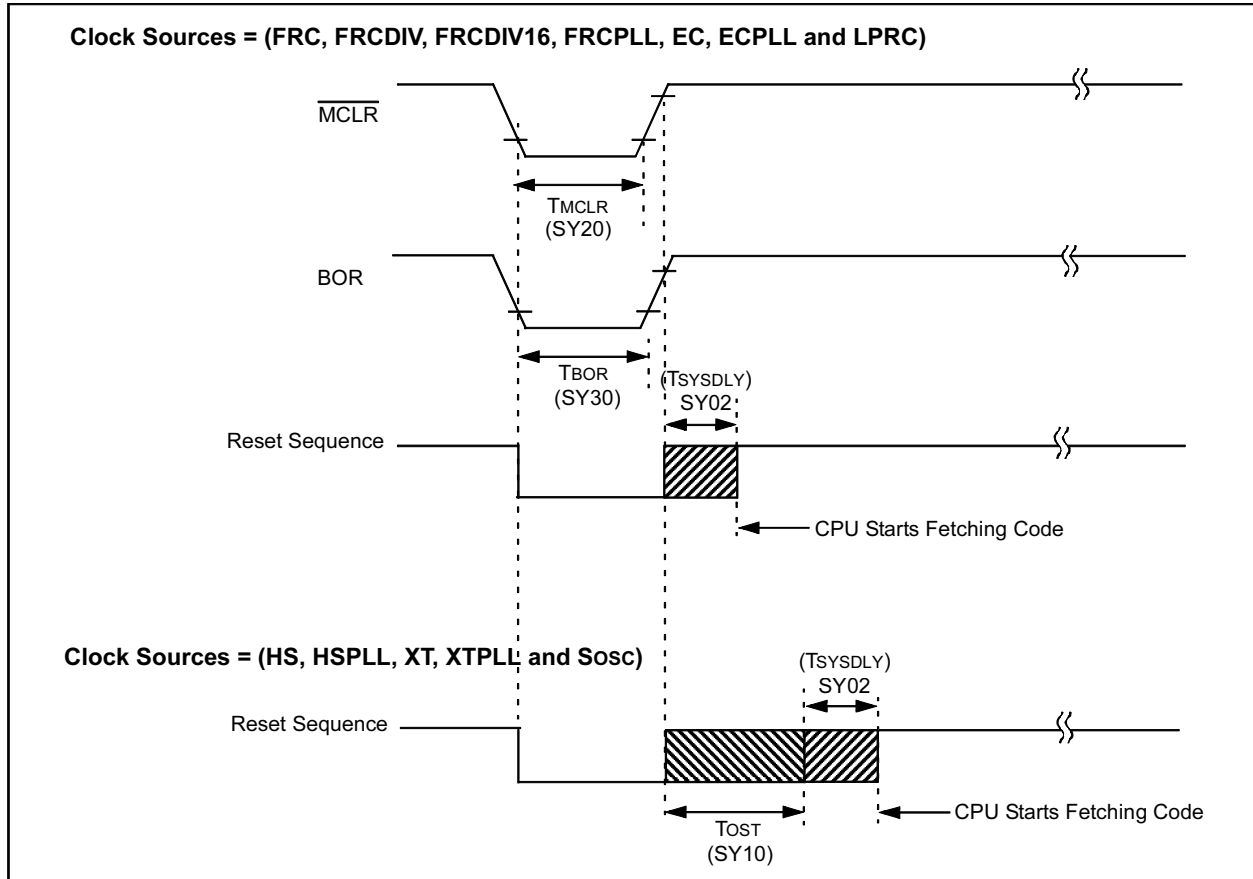

TABLE 31-22: RESETS TIMING

AC CHARACTERISTICS			Standard Operating Conditions: 2.3V to 3.6V (unless otherwise stated) Operating temperature $-40^{\circ}\text{C} \leq T_A \leq +85^{\circ}\text{C}$ for Industrial $-40^{\circ}\text{C} \leq T_A \leq +105^{\circ}\text{C}$ for V-Temp				
Param. No.	Symbol	Characteristics ⁽¹⁾	Min.	Typical ⁽²⁾	Max.	Units	Conditions
SY00	TPU	Power-up Period Internal Voltage Regulator Enabled	—	400	600	μs	-40°C to $+85^{\circ}\text{C}$
SY01	TPWRT	Power-up Period External V _{CORE} Applied (Power-up timer active)	48	64	80	ms	-40°C to $+85^{\circ}\text{C}$
SY02	TSYSDLY	System Delay Period: Time Required to Reload Device Configuration Fuses plus SYSCLK Delay before First instruction is Fetched.	—	$1 \mu\text{s} +$ 8 SYSCLK cycles	—	—	-40°C to $+85^{\circ}\text{C}$
SY20	TMCLR	MCLR Pulse Width (low)	—	2	—	μs	-40°C to $+85^{\circ}\text{C}$
SY30	TBOR	BOR Pulse Width (low)	—	1	—	μs	-40°C to $+85^{\circ}\text{C}$

Note 1: These parameters are characterized, but not tested in manufacturing.

Note 2: Data in "Typ" column is at 3.3V, 25°C unless otherwise stated. Characterized by design but not tested.

FIGURE 31-6: TIMER1, 2, 3, 4, 5 EXTERNAL CLOCK TIMING CHARACTERISTICS

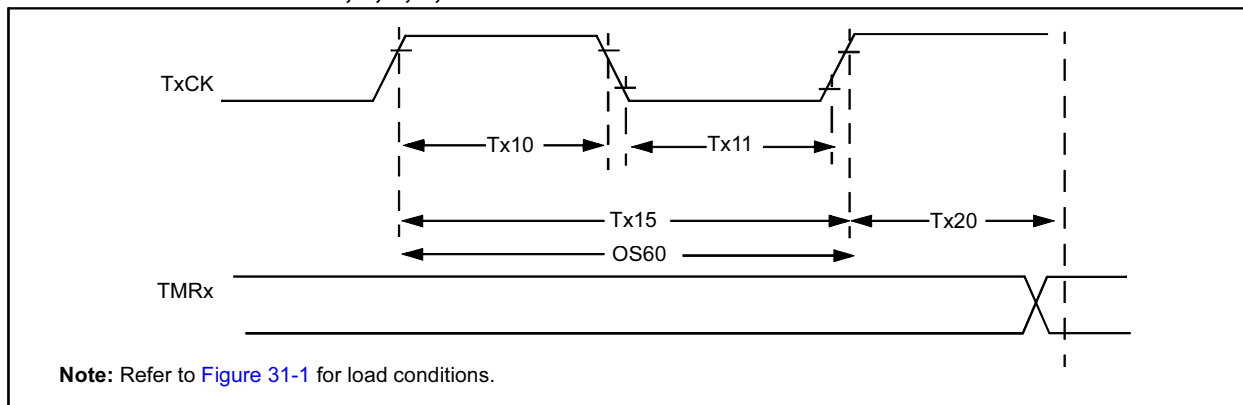

TABLE 31-23: TIMER1 EXTERNAL CLOCK TIMING REQUIREMENTS⁽¹⁾

AC CHARACTERISTICS		Standard Operating Conditions: 2.3V to 3.6V (unless otherwise stated) Operating temperature -40°C ≤ TA ≤ +85°C for Industrial -40°C ≤ TA ≤ +105°C for V-Temp						
Param. No.	Symbol	Characteristics ⁽²⁾		Min.	Typical	Max.	Units	Conditions
TA10	TtxH	TxCK High Time	Synchronous, with prescaler	$[(12.5 \text{ ns or } 1 \text{ TPB})/N] + 25 \text{ ns}$	—	—	ns	Must also meet parameter TA15
			Asynchronous, with prescaler	10	—	—	ns	—
TA11	TtxL	TxCK Low Time	Synchronous, with prescaler	$[(12.5 \text{ ns or } 1 \text{ TPB})/N] + 25 \text{ ns}$	—	—	ns	Must also meet parameter TA15
			Asynchronous, with prescaler	10	—	—	ns	—
TA15	TtxP	TxCK Input Period	Synchronous, with prescaler	$[(\text{Greater of } 25 \text{ ns or } 2 \text{ TPB})/N] + 30 \text{ ns}$	—	—	ns	VDD > 2.7V
				$[(\text{Greater of } 25 \text{ ns or } 2 \text{ TPB})/N] + 50 \text{ ns}$	—	—	ns	VDD < 2.7V
			Asynchronous, with prescaler	20	—	—	ns	VDD > 2.7V (Note 3)
				50	—	—	ns	VDD < 2.7V (Note 3)
OS60	Ft1	SOSC1/T1CK Oscillator Input Frequency Range (oscillator enabled by setting TCS bit (T1CON<1>))		32	—	100	kHz	—
TA20	TCKEXTMRL	Delay from External TxCK Clock Edge to Timer Increment		—	—	1	TPB	—

Note 1: Timer1 is a Type A.

Note 2: This parameter is characterized, but not tested in manufacturing.

Note 3: N = Prescale Value (1, 8, 64, 256).

TABLE 31-24: TIMER2, 3, 4, 5 EXTERNAL CLOCK TIMING REQUIREMENTS

AC CHARACTERISTICS		Standard Operating Conditions: 2.3V to 3.6V (unless otherwise stated) Operating temperature -40°C ≤TA ≤+85°C for Industrial -40°C ≤TA ≤+105°C for V-Temp					
Param. No.	Symbol	Characteristics ⁽¹⁾		Min.	Max.	Units	Conditions
TB10	T _{TXH}	TxCK High Time	Synchronous, with prescaler	$[(12.5 \text{ ns or } 1 \text{ TPB})/N] + 25 \text{ ns}$	—	ns	Must also meet parameter TB15
TB11	T _{TXL}	TxCK Low Time	Synchronous, with prescaler	$[(12.5 \text{ ns or } 1 \text{ TPB})/N] + 25 \text{ ns}$	—	ns	Must also meet parameter TB15
TB15	T _{TXP}	TxCK Input Period	Synchronous, with prescaler	$[(\text{Greater of } [(25 \text{ ns or } 2 \text{ TPB})/N] + 30 \text{ ns})]$	—	ns	VDD > 2.7V
				$[(\text{Greater of } [(25 \text{ ns or } 2 \text{ TPB})/N] + 50 \text{ ns})]$	—	ns	VDD < 2.7V
TB20	T _{CKEXTMRL}	Delay from External TxCK Clock Edge to Timer Increment		—	1	TPB	—

Note 1: These parameters are characterized, but not tested in manufacturing.

FIGURE 31-7: INPUT CAPTURE (CAPx) TIMING CHARACTERISTICS

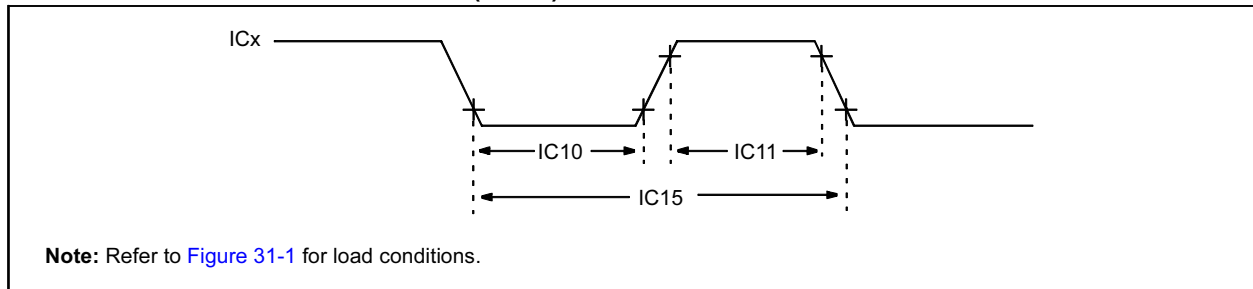

Note: Refer to Figure 31-1 for load conditions.

TABLE 31-25: INPUT CAPTURE MODULE TIMING REQUIREMENTS

AC CHARACTERISTICS		Standard Operating Conditions: 2.3V to 3.6V (unless otherwise stated) Operating temperature -40°C ≤TA ≤+85°C for Industrial -40°C ≤TA ≤+105°C for V-Temp					
Param. No.	Symbol	Characteristics ⁽¹⁾		Min.	Max.	Units	Conditions
IC10	T _{cCL}	ICx Input Low Time		$[(12.5 \text{ ns or } 1 \text{ TPB})/N] + 25 \text{ ns}$	—	ns	Must also meet parameter IC15.
IC11	T _{cCH}	ICx Input High Time		$[(12.5 \text{ ns or } 1 \text{ TPB})/N] + 25 \text{ ns}$	—	ns	Must also meet parameter IC15.
IC15	T _{cCP}	ICx Input Period		$[(25 \text{ ns or } 2 \text{ TPB})/N] + 50 \text{ ns}$	—	ns	—

Note 1: These parameters are characterized, but not tested in manufacturing.

FIGURE 31-8: OUTPUT COMPARE MODULE (OCx) TIMING CHARACTERISTICS

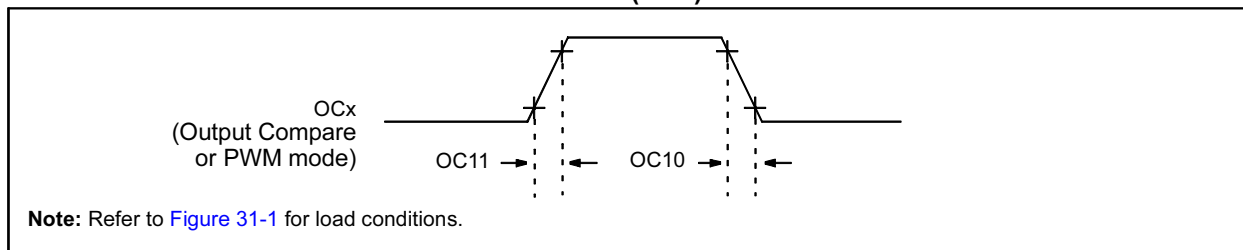

TABLE 31-26: OUTPUT COMPARE MODULE TIMING REQUIREMENTS

AC CHARACTERISTICS			Standard Operating Conditions: 2.3V to 3.6V (unless otherwise stated) Operating temperature -40°C ≤TA ≤+85°C for Industrial -40°C ≤TA ≤+105°C for V-Temp				
Param. No.	Symbol	Characteristics ⁽¹⁾	Min.	Typical ⁽²⁾	Max.	Units	Conditions
OC10	TccF	OCx Output Fall Time	—	—	—	ns	See parameter DO32
OC11	TccR	OCx Output Rise Time	—	—	—	ns	See parameter DO31

- Note 1:** These parameters are characterized, but not tested in manufacturing.
Note 2: Data in “Typical” column is at 3.3V, 25°C unless otherwise stated. Parameters are for design guidance only and are not tested.

FIGURE 31-9: OCx/PWM MODULE TIMING CHARACTERISTICS

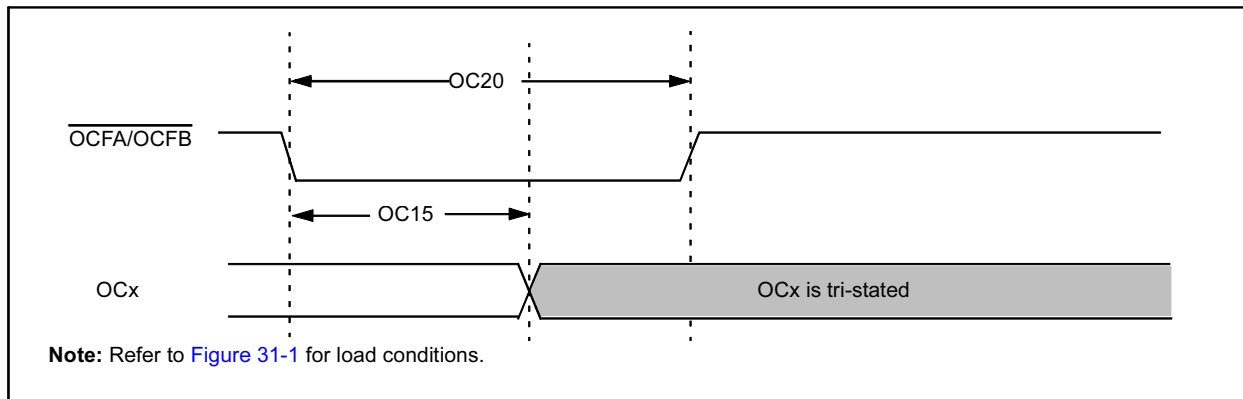

TABLE 31-27: SIMPLE OCx/PWM MODE TIMING REQUIREMENTS

AC CHARACTERISTICS			Standard Operating Conditions: 2.3V to 3.6V (unless otherwise stated) Operating temperature -40°C ≤TA ≤+85°C for Industrial -40°C ≤TA ≤+105°C for V-Temp				
Param No.	Symbol	Characteristics ⁽¹⁾	Min	Typical ⁽²⁾	Max	Units	Conditions
OC15	TFD	Fault Input to PWM I/O Change	—	—	50	ns	—
OC20	TFLT	Fault Input Pulse Width	50	—	—	ns	—

- Note 1:** These parameters are characterized, but not tested in manufacturing.
Note 2: Data in “Typical” column is at 3.3V, 25°C unless otherwise stated. Parameters are for design guidance only and are not tested.

FIGURE 31-10: SPIx MODULE MASTER MODE (CKE = 0) TIMING CHARACTERISTICS

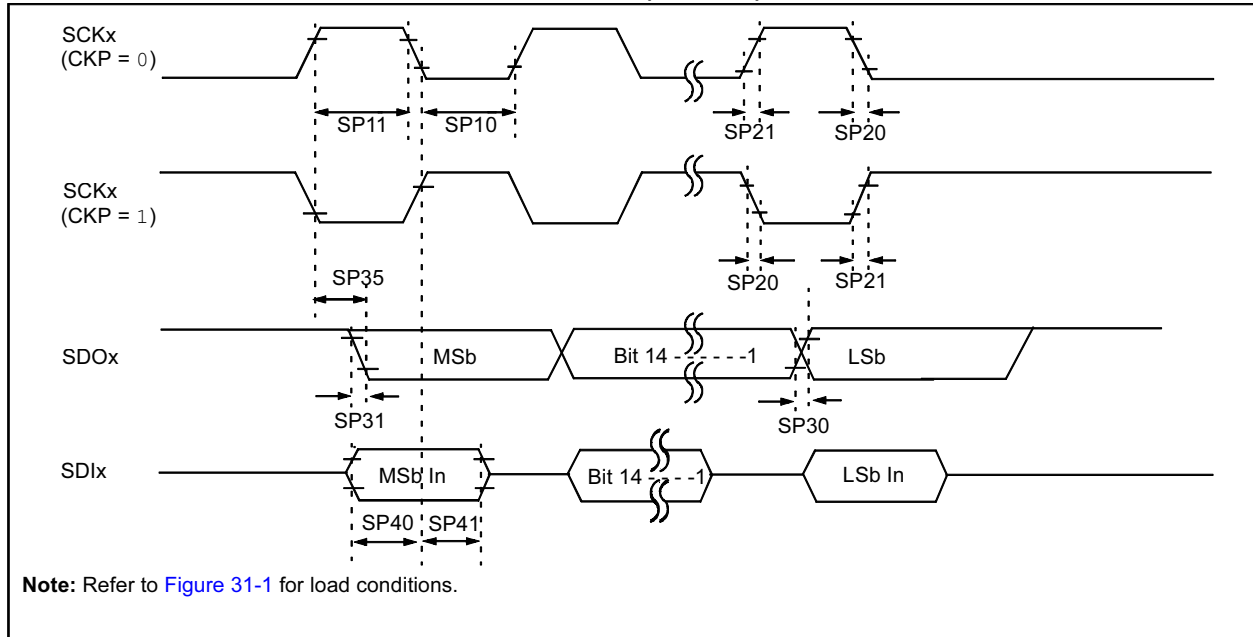

TABLE 31-28: SPIx MASTER MODE (CKE = 0) TIMING REQUIREMENTS

AC CHARACTERISTICS			Standard Operating Conditions: 2.3V to 3.6V (unless otherwise stated) Operating temperature -40°C ≤ TA ≤ +85°C for Industrial -40°C ≤ TA ≤ +105°C for V-Temp				
Param. No.	Symbol	Characteristics ⁽¹⁾	Min.	Typical ⁽²⁾	Max.	Units	Conditions
SP10	TsCL	SCKx Output Low Time ⁽³⁾	TsCK/2	—	—	ns	—
SP11	TsCH	SCKx Output High Time ⁽³⁾	TsCK/2	—	—	ns	—
SP20	TsCF	SCKx Output Fall Time ⁽⁴⁾	—	—	—	ns	See parameter DO32
SP21	TsCR	SCKx Output Rise Time ⁽⁴⁾	—	—	—	ns	See parameter DO31
SP30	TdOF	SDOx Data Output Fall Time ⁽⁴⁾	—	—	—	ns	See parameter DO32
SP31	TdOR	SDOx Data Output Rise Time ⁽⁴⁾	—	—	—	ns	See parameter DO31
SP35	TsCH2doV, TsCL2doV	SDOx Data Output Valid after SCKx Edge	—	—	15	ns	VDD > 2.7V
			—	—	20	ns	VDD < 2.7V
SP40	TdIV2sCH, TdIV2sCL	Setup Time of SDIx Data Input to SCKx Edge	10	—	—	ns	—
SP41	TsCH2dIL, TsCL2dIL	Hold Time of SDIx Data Input to SCKx Edge	10	—	—	ns	—

- Note 1:** These parameters are characterized, but not tested in manufacturing.
- Note 2:** Data in "Typical" column is at 3.3V, 25°C unless otherwise stated. Parameters are for design guidance only and are not tested.
- Note 3:** The minimum clock period for SCKx is 40 ns. Therefore, the clock generated in Master mode must not violate this specification.
- Note 4:** Assumes 50 pF load on all SPIx pins.

FIGURE 31-11: SPIx MODULE MASTER MODE (CKE = 1) TIMING CHARACTERISTICS

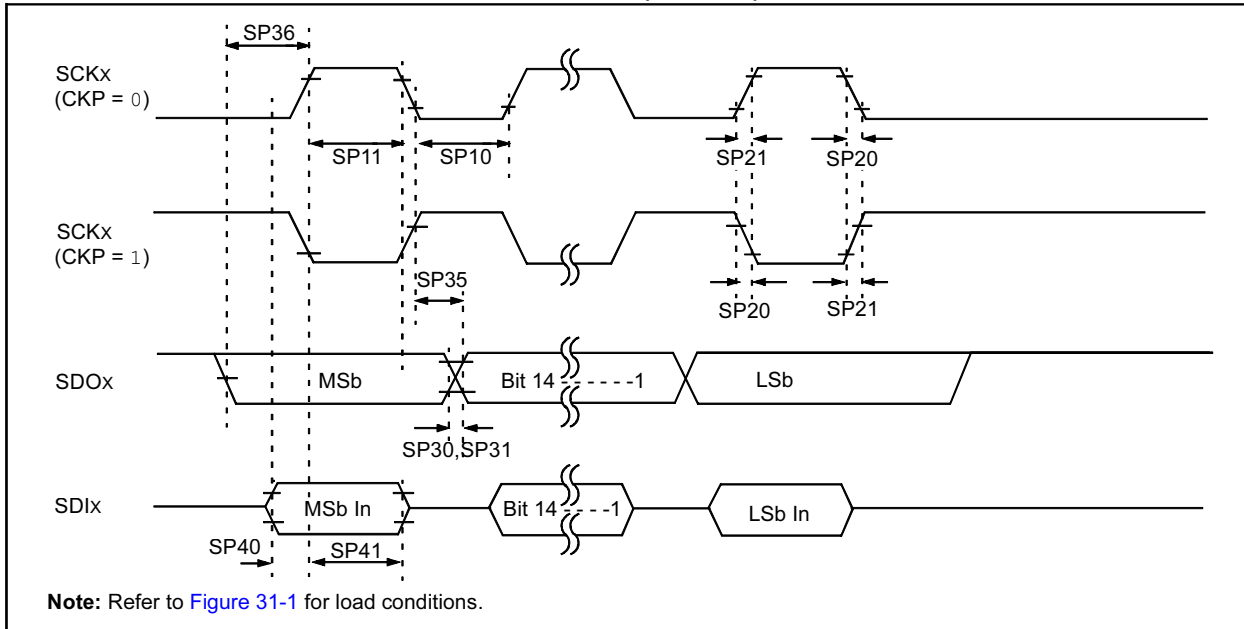

TABLE 31-29: SPIx MODULE MASTER MODE (CKE = 1) TIMING REQUIREMENTS

AC CHARACTERISTICS			Standard Operating Conditions: 2.3V to 3.6V (unless otherwise stated) Operating temperature -40°C ≤ TA ≤ +85°C for Industrial -40°C ≤ TA ≤ +105°C for V-Temp				
Param. No.	Symbol	Characteristics ⁽¹⁾	Min.	Typ. ⁽²⁾	Max.	Units	Conditions
SP10	TscL	SCKx Output Low Time ⁽³⁾	Tsck/2	—	—	ns	—
SP11	TscH	SCKx Output High Time ⁽³⁾	Tsck/2	—	—	ns	—
SP20	TscF	SCKx Output Fall Time ⁽⁴⁾	—	—	—	ns	See parameter DO32
SP21	TscR	SCKx Output Rise Time ⁽⁴⁾	—	—	—	ns	See parameter DO31
SP30	TdoF	SDOx Data Output Fall Time ⁽⁴⁾	—	—	—	ns	See parameter DO32
SP31	TdoR	SDOx Data Output Rise Time ⁽⁴⁾	—	—	—	ns	See parameter DO31
SP35	Tsch2doV, TscL2doV	SDOx Data Output Valid after SCKx Edge	—	—	15	ns	VDD > 2.7V
			—	—	20	ns	VDD < 2.7V
SP36	TdoV2sc, TdoV2scL	SDOx Data Output Setup to First SCKx Edge	15	—	—	ns	—
SP40	TdiV2sch, TdiV2scL	Setup Time of SDIx Data Input to SCKx Edge	15	—	—	ns	VDD > 2.7V
			20	—	—	ns	VDD < 2.7V
SP41	Tsch2diL, TscL2diL	Hold Time of SDIx Data Input to SCKx Edge	15	—	—	ns	VDD > 2.7V
			20	—	—	ns	VDD < 2.7V

- Note 1:** These parameters are characterized, but not tested in manufacturing.
- Note 2:** Data in “Typical” column is at 3.3V, 25°C unless otherwise stated. Parameters are for design guidance only and are not tested.
- Note 3:** The minimum clock period for SCKx is 40 ns. Therefore, the clock generated in Master mode must not violate this specification.
- Note 4:** Assumes 50 pF load on all SPIx pins.

FIGURE 31-12: SPIx MODULE SLAVE MODE (CKE = 0) TIMING CHARACTERISTICS

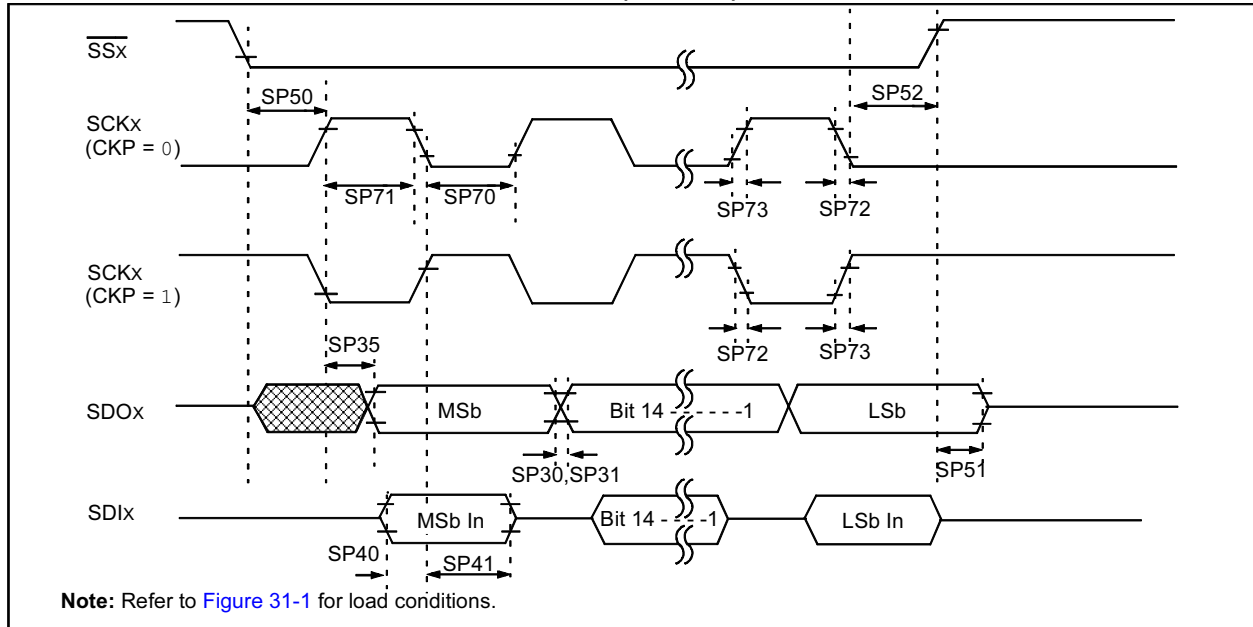

TABLE 31-30: SPIx MODULE SLAVE MODE (CKE = 0) TIMING REQUIREMENTS

AC CHARACTERISTICS		Standard Operating Conditions: 2.3V to 3.6V (unless otherwise stated) Operating temperature $-40^{\circ}\text{C} \leq T_A \leq +85^{\circ}\text{C}$ for Industrial $-40^{\circ}\text{C} \leq T_A \leq +105^{\circ}\text{C}$ for V-Temp					
Param. No.	Symbol	Characteristics ⁽¹⁾	Min.	Typ. ⁽²⁾	Max.	Units	Conditions
SP70	TscL	SCKx Input Low Time ⁽³⁾	$T_{\text{SCK}}/2$	—	—	ns	—
SP71	TscH	SCKx Input High Time ⁽³⁾	$T_{\text{SCK}}/2$	—	—	ns	—
SP72	TscF	SCKx Input Fall Time	—	—	—	ns	See parameter DO32
SP73	TscR	SCKx Input Rise Time	—	—	—	ns	See parameter DO31
SP30	TdoF	SDOx Data Output Fall Time ⁽⁴⁾	—	—	—	ns	See parameter DO32
SP31	TdoR	SDOx Data Output Rise Time ⁽⁴⁾	—	—	—	ns	See parameter DO31
SP35	Tsch2boV, TscL2doV	SDOx Data Output Valid after SCKx Edge	—	—	15	ns	$V_{\text{DD}} > 2.7\text{V}$
			—	—	20	ns	$V_{\text{DD}} < 2.7\text{V}$
SP40	TdIV2sch, TdIV2scl	Setup Time of SDIx Data Input to SCKx Edge	10	—	—	ns	—
SP41	Tsch2dIL, TscL2dIL	Hold Time of SDIx Data Input to SCKx Edge	10	—	—	ns	—
SP50	Tssl2sch, Tssl2scl	$\overline{\text{SSx}} \downarrow$ to SCKx \uparrow or SCKx Input	175	—	—	ns	—
SP51	Tssh2boZ	$\overline{\text{SSx}} \uparrow$ to SDOx Output High-Impedance ⁽³⁾	5	—	25	ns	—
SP52	Tsch2ssh, TscL2ssh	$\overline{\text{SSx}}$ after SCKx Edge	$T_{\text{SCK}} + 20$	—	—	ns	—

Note 1: These parameters are characterized, but not tested in manufacturing.

Note 2: Data in “Typical” column is at 3.3V, 25°C unless otherwise stated. Parameters are for design guidance only and are not tested.

Note 3: The minimum clock period for SCKx is 40 ns.

Note 4: Assumes 50 pF load on all SPIx pins.

FIGURE 31-13: SPIx MODULE SLAVE MODE (CKE = 1) TIMING CHARACTERISTICS

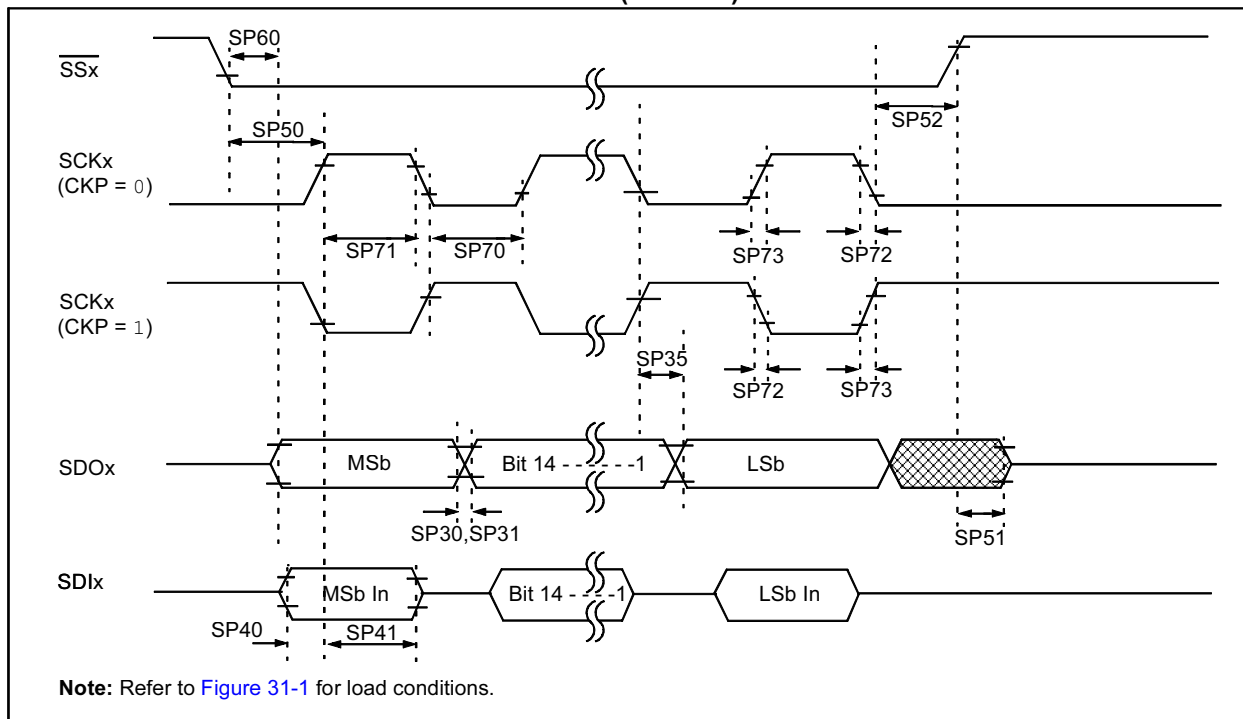

TABLE 31-31: SPIx MODULE SLAVE MODE (CKE = 1) TIMING REQUIREMENTS

AC CHARACTERISTICS			Standard Operating Conditions: 2.3V to 3.6V (unless otherwise stated) Operating temperature -40°C ≤TA ≤+85°C for Industrial -40°C ≤TA ≤+105°C for V-Temp				
Param. No.	Symbol	Characteristics ⁽¹⁾	Min.	Typical ⁽²⁾	Max.	Units	Conditions
SP70	TscL	SCKx Input Low Time ⁽³⁾	Tsck/2	—	—	ns	—
SP71	Tsch	SCKx Input High Time ⁽³⁾	Tsck/2	—	—	ns	—
SP72	TscF	SCKx Input Fall Time	—	5	10	ns	—
SP73	TscR	SCKx Input Rise Time	—	5	10	ns	—
SP30	TdoF	SDOx Data Output Fall Time ⁽⁴⁾	—	—	—	ns	See parameter DO32
SP31	TdoR	SDOx Data Output Rise Time ⁽⁴⁾	—	—	—	ns	See parameter DO31
SP35	Tsch2doV, TscL2doV	SDOx Data Output Valid after SCKx Edge	—	—	20	ns	VDD > 2.7V
			—	—	30	ns	VDD < 2.7V
SP40	TdiV2sch, TdiV2scl	Setup Time of SDIx Data Input to SCKx Edge	10	—	—	ns	—
SP41	Tsch2dil, TscL2dil	Hold Time of SDIx Data Input to SCKx Edge	10	—	—	ns	—
SP50	Tssl2sch, Tssl2scl	SSx ↓ to SCKx ↓ or SCKx ↑ Input	175	—	—	ns	—

Note 1: These parameters are characterized, but not tested in manufacturing.

2: Data in “Typical” column is at 3.3V, 25°C unless otherwise stated. Parameters are for design guidance only and are not tested.

3: The minimum clock period for SCKx is 40 ns.

4: Assumes 50 pF load on all SPIx pins.

TABLE 31-31: SPIx MODULE SLAVE MODE (CKE = 1) TIMING REQUIREMENTS (CONTINUED)

AC CHARACTERISTICS			Standard Operating Conditions: 2.3V to 3.6V (unless otherwise stated) Operating temperature -40°C ≤TA ≤+85°C for Industrial -40°C ≤TA ≤+105°C for V-Temp				
Param. No.	Symbol	Characteristics ⁽¹⁾	Min.	Typical ⁽²⁾	Max.	Units	Conditions
SP51	TssH2doZ	\overline{SSx} ↑ to SDOx Output High-Impedance ⁽⁴⁾	5	—	25	ns	—
SP52	Tsch2ssH TscL2ssH	\overline{SSx} ↑ after SCKx Edge	Tsck + 20	—	—	ns	—
SP60	TssL2doV	SDOx Data Output Valid after \overline{SSx} Edge	—	—	25	ns	—

Note 1: These parameters are characterized, but not tested in manufacturing.

2: Data in “Typical” column is at 3.3V, 25°C unless otherwise stated. Parameters are for design guidance only and are not tested.

3: The minimum clock period for SCKx is 40 ns.

4: Assumes 50 pF load on all SPIx pins.

FIGURE 31-14: I2Cx BUS START/STOP BITS TIMING CHARACTERISTICS (MASTER MODE)

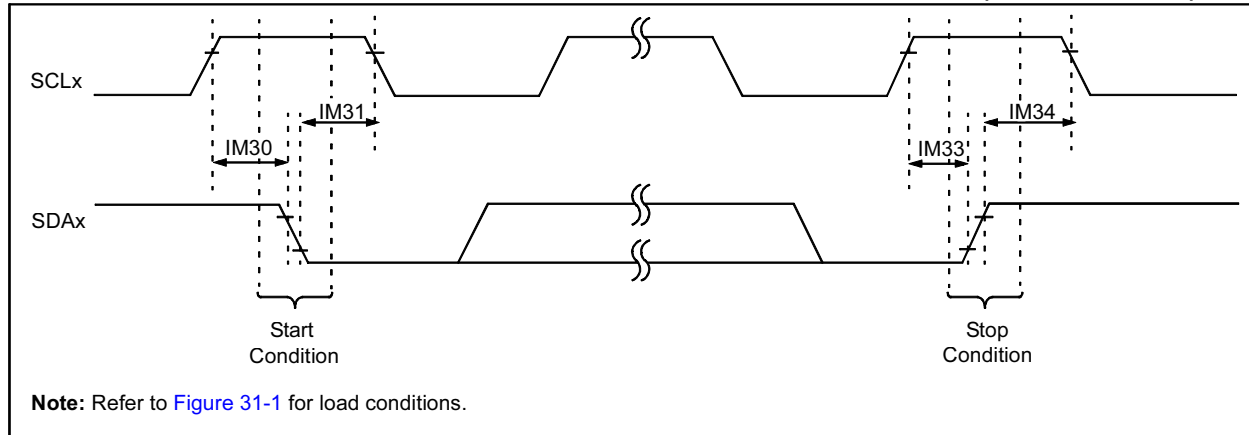

FIGURE 31-15: I2Cx BUS DATA TIMING CHARACTERISTICS (MASTER MODE)

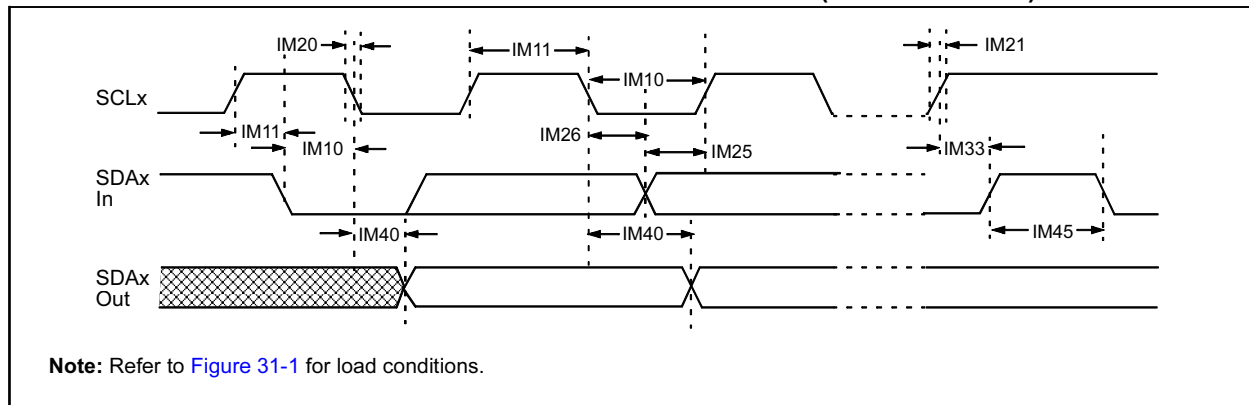

TABLE 31-32: I2Cx BUS DATA TIMING REQUIREMENTS (MASTER MODE)

AC CHARACTERISTICS				Standard Operating Conditions: 2.3V to 3.6V (unless otherwise stated) Operating temperature $-40^{\circ}\text{C} \leq T_A \leq +85^{\circ}\text{C}$ for Industrial $-40^{\circ}\text{C} \leq T_A \leq +105^{\circ}\text{C}$ for V-Temp			
Param. No.	Symbol	Characteristics		Min. ⁽¹⁾	Max.	Units	Conditions
IM10	TLO:SCL	Clock Low Time	100 kHz mode	$T_{PB} * (BRG + 2)$	—	μs	—
			400 kHz mode	$T_{PB} * (BRG + 2)$	—	μs	—
			1 MHz mode ⁽²⁾	$T_{PB} * (BRG + 2)$	—	μs	—
IM11	THI:SCL	Clock High Time	100 kHz mode	$T_{PB} * (BRG + 2)$	—	μs	—
			400 kHz mode	$T_{PB} * (BRG + 2)$	—	μs	—
			1 MHz mode ⁽²⁾	$T_{PB} * (BRG + 2)$	—	μs	—
IM20	TF:SCL	SDAx and SCLx Fall Time	100 kHz mode	—	300	ns	Cb is specified to be from 10 to 400 pF
			400 kHz mode	$20 + 0.1 C_B$	300	ns	
			1 MHz mode ⁽²⁾	—	100	ns	
IM21	TR:SCL	SDAx and SCLx Rise Time	100 kHz mode	—	1000	ns	Cb is specified to be from 10 to 400 pF
			400 kHz mode	$20 + 0.1 C_B$	300	ns	
			1 MHz mode ⁽²⁾	—	300	ns	
IM25	TSU:DAT	Data Input Setup Time	100 kHz mode	250	—	ns	—
			400 kHz mode	100	—	ns	
			1 MHz mode ⁽²⁾	100	—	ns	
IM26	THD:DAT	Data Input Hold Time	100 kHz mode	0	—	μs	—
			400 kHz mode	0	0.9	μs	
			1 MHz mode ⁽²⁾	0	0.3	μs	
IM30	TSU:STA	Start Condition Setup Time	100 kHz mode	$T_{PB} * (BRG + 2)$	—	ns	Only relevant for Repeated Start condition
			400 kHz mode	$T_{PB} * (BRG + 2)$	—	ns	
			1 MHz mode ⁽²⁾	$T_{PB} * (BRG + 2)$	—	ns	
IM31	THD:STA	Start Condition Hold Time	100 kHz mode	$T_{PB} * (BRG + 2)$	—	ns	After this period, the first clock pulse is generated
			400 kHz mode	$T_{PB} * (BRG + 2)$	—	ns	
			1 MHz mode ⁽²⁾	$T_{PB} * (BRG + 2)$	—	ns	
IM33	TSU:STO	Stop Condition Setup Time	100 kHz mode	$T_{PB} * (BRG + 2)$	—	ns	—
			400 kHz mode	$T_{PB} * (BRG + 2)$	—	ns	
			1 MHz mode ⁽²⁾	$T_{PB} * (BRG + 2)$	—	ns	
IM34	THD:STO	Stop Condition Hold Time	100 kHz mode	$T_{PB} * (BRG + 2)$	—	ns	—
			400 kHz mode	$T_{PB} * (BRG + 2)$	—	ns	
			1 MHz mode ⁽²⁾	$T_{PB} * (BRG + 2)$	—	ns	
IM40	TAA:SCL	Output Valid from Clock	100 kHz mode	—	3500	ns	—
			400 kHz mode	—	1000	ns	
			1 MHz mode ⁽²⁾	—	350	ns	
IM45	TBF:SDA	Bus Free Time	100 kHz mode	4.7	—	μs	The amount of time the bus must be free before a new transmission can start
			400 kHz mode	1.3	—	μs	
			1 MHz mode ⁽²⁾	0.5	—	μs	
IM50	CB	Bus Capacitive Loading		—	400	pF	—
IM51	TPGD	Pulse Gobbler Delay ⁽³⁾		52	312	ns	—

Note 1: BRG is the value of the I²C™ Baud Rate Generator.

2: Maximum pin capacitance = 10 pF for all I2Cx pins (for 1 MHz mode only).

FIGURE 31-16: I2Cx BUS START/STOP BITS TIMING CHARACTERISTICS (SLAVE MODE)

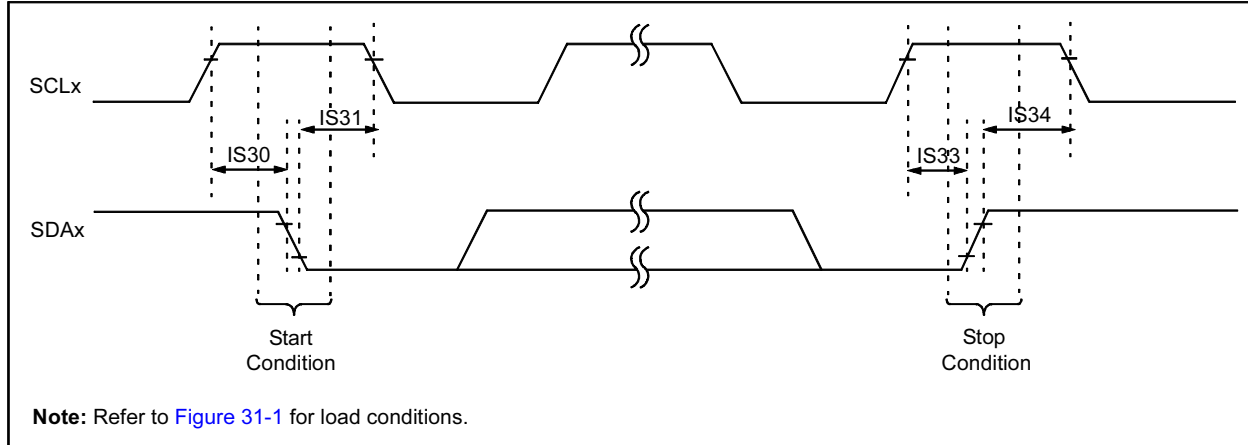

FIGURE 31-17: I2Cx BUS DATA TIMING CHARACTERISTICS (SLAVE MODE)

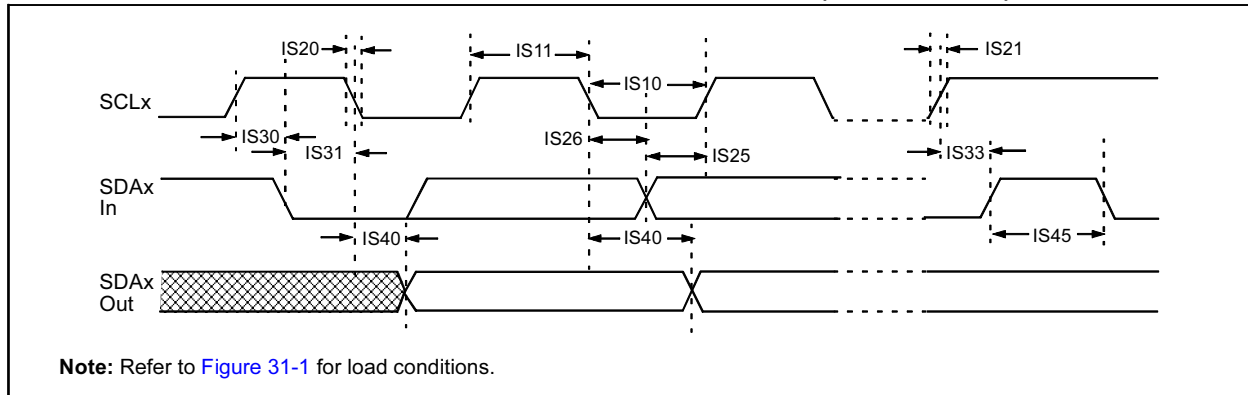

TABLE 31-33: I2Cx BUS DATA TIMING REQUIREMENTS (SLAVE MODE)

AC CHARACTERISTICS				Standard Operating Conditions: 2.3V to 3.6V (unless otherwise stated) Operating temperature -40°C ≤ TA ≤ +85°C for Industrial -40°C ≤ TA ≤ +105°C for V-Temp			
Param. No.	Symbol	Characteristics		Min.	Max.	Units	Conditions
IS10	TLO:SCL	Clock Low Time	100 kHz mode	4.7	—	μs	PBCLK must operate at a minimum of 800 kHz
			400 kHz mode	1.3	—	μs	PBCLK must operate at a minimum of 3.2 MHz
			1 MHz mode ⁽¹⁾	0.5	—	μs	—
IS11	THI:SCL	Clock High Time	100 kHz mode	4.0	—	μs	PBCLK must operate at a minimum of 800 kHz
			400 kHz mode	0.6	—	μs	PBCLK must operate at a minimum of 3.2 MHz
			1 MHz mode ⁽¹⁾	0.5	—	μs	—
IS20	TF:SCL	SDAx and SCLx Fall Time	100 kHz mode	—	300	ns	Cb is specified to be from 10 to 400 pF
			400 kHz mode	20 + 0.1 C _B	300	ns	
			1 MHz mode ⁽¹⁾	—	100	ns	
IS21	Tr:SCL	SDAx and SCLx Rise Time	100 kHz mode	—	1000	ns	Cb is specified to be from 10 to 400 pF
			400 kHz mode	20 + 0.1 C _B	300	ns	
			1 MHz mode ⁽¹⁾	—	300	ns	
IS25	TSU:DAT	Data Input Setup Time	100 kHz mode	250	—	ns	—
			400 kHz mode	100	—	ns	
			1 MHz mode ⁽¹⁾	100	—	ns	
IS26	THD:DAT	Data Input Hold Time	100 kHz mode	0	—	ns	—
			400 kHz mode	0	0.9	μs	
			1 MHz mode ⁽¹⁾	0	0.3	μs	
IS30	TSU:STA	Start Condition Setup Time	100 kHz mode	4700	—	ns	Only relevant for Repeated Start condition
			400 kHz mode	600	—	ns	
			1 MHz mode ⁽¹⁾	250	—	ns	
IS31	THD:STA	Start Condition Hold Time	100 kHz mode	4000	—	ns	After this period, the first clock pulse is generated
			400 kHz mode	600	—	ns	
			1 MHz mode ⁽¹⁾	250	—	ns	
IS33	TSU:STO	Stop Condition Setup Time	100 kHz mode	4000	—	ns	—
			400 kHz mode	600	—	ns	
			1 MHz mode ⁽¹⁾	600	—	ns	
IS34	THD:STO	Stop Condition Hold Time	100 kHz mode	4000	—	ns	—
			400 kHz mode	600	—	ns	
			1 MHz mode ⁽¹⁾	250	—	ns	
IS40	TAA:SCL	Output Valid from Clock	100 kHz mode	0	3500	ns	—
			400 kHz mode	0	1000	ns	
			1 MHz mode ⁽¹⁾	0	350	ns	
IS45	TBF:SDA	Bus Free Time	100 kHz mode	4.7	—	μs	The amount of time the bus must be free before a new transmission can start
			400 kHz mode	1.3	—	μs	
			1 MHz mode ⁽¹⁾	0.5	—	μs	
IS50	C _B	Bus Capacitive Loading		—	400	pF	—

Note 1: Maximum pin capacitance = 10 pF for all I2Cx pins (for 1 MHz mode only).

FIGURE 31-18: CAN MODULE I/O TIMING CHARACTERISTICS

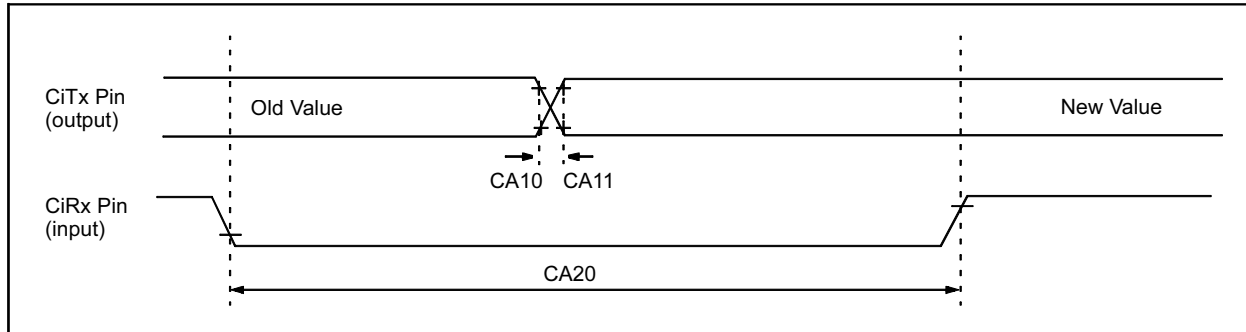

TABLE 31-34: CAN MODULE I/O TIMING REQUIREMENTS

AC CHARACTERISTICS			Standard Operating Conditions: 2.3V to 3.6V (unless otherwise stated) Operating temperature -40°C ≤ TA ≤ +85°C for Industrial -40°C ≤ TA ≤ +105°C for V-Temp				
Param No.	Symbol	Characteristic ⁽¹⁾	Min	Typ ⁽²⁾	Max	Units	Conditions
CA10	TioF	Port Output Fall Time	—	—	—	ns	See parameter D032
CA11	TioR	Port Output Rise Time	—	—	—	ns	See parameter D031
CA20	Tcwf	Pulse Width to Trigger CAN Wake-up Filter	700	—	—	ns	—

Note 1: These parameters are characterized but not tested in manufacturing.

2: Data in “Typ” column is at 3.3V, 25°C unless otherwise stated. Parameters are for design guidance only and are not tested.

TABLE 31-35: ETHERNET MODULE SPECIFICATIONS

AC CHARACTERISTICS		Standard Operating Conditions: 2.3V to 3.6V (unless otherwise stated) Operating temperature -40°C ≤TA ≤+85°C for Industrial -40°C ≤TA ≤+105°C for V-Temp				
Param. No.	Characteristic	Min.	Typical	Max.	Units	Conditions
MIIM Timing Requirements						
ET1	MDC Duty Cycle	40	—	60	%	—
ET2	MDC Period	400	—	—	ns	—
ET3	MDIO Output Delay	10	—	10	ns	—
ET4	MDIO Input Delay	0	—	300	ns	—
MII Timing Requirements						
ET5	TX Clock Frequency	—	25	—	MHz	—
ET6	TX Clock Duty Cycle	35	—	65	%	—
ET7	ETXDx, ETEN, ETXERR Delay	0	—	25	ns	—
ET8	RX Clock Frequency	—	25	—	MHz	—
ET9	RX Clock Duty Cycle	35	—	65	%	—
ET10	ERXDx, ERXDV, ERXERR Delay	10	—	30	ns	—
RMI Timing Requirements						
ET11	Reference Clock Frequency	—	50	—	MHz	—
ET12	Reference Clock Duty Cycle	35	—	65	%	—
ET13	ETXDx, ETEN, Delay	2	—	16	ns	—
ET14	ERXDx, ERXDV, ERXERR Delay	2	—	16	ns	—

TABLE 31-36: ADC MODULE SPECIFICATIONS⁽⁵⁾

AC CHARACTERISTICS			Standard Operating Conditions: 2.3V to 3.6V (unless otherwise stated) Operating temperature -40°C ≤TA ≤+85°C for Industrial -40°C ≤TA ≤+105°C for V-Temp				
Param. No.	Symbol	Characteristics	Min.	Typical	Max.	Units	Conditions
Device Supply							
AD01	AVDD	Module VDD Supply	Greater of VDD – 0.3 or 2.5	—	Lesser of VDD + 0.3 or 3.6	V	—
AD02	AVSS	Module VSS Supply	VSS	—	VSS + 0.3	V	—
Reference Inputs							
AD05	VREFH	Reference Voltage High	AVSS + 2.0	—	AVDD	V	(Note 1)
AD05a			2.5	—	3.6	V	VREFH = AVDD (Note 3)
AD06	VREFL	Reference Voltage Low	AVSS	—	VREFH – 2.0	V	(Note 1)
AD07	VREF	Absolute Reference Voltage (VREFH – VREFL)	2.0	—	AVDD	V	(Note 3)
AD08	IREF	Current Drain	—	250 —	400 3	μA μA	ADC operating ADC off
Analog Input							
AD12	VINH-VINL	Full-Scale Input Span	VREFL	—	VREFH	V	—
AD13	VINL	Absolute VINL Input Voltage	AVSS – 0.3	—	AVDD/2	V	—
AD14	VIN	Absolute Input Voltage	AVSS – 0.3	—	AVDD + 0.3	V	—
AD15		Leakage Current	—	+/- 0.001	+/-0.610	μA	VINL = AVSS = VREFL = 0V, AVDD = VREFH = 3.3V Source Impedance = 10 kΩ
AD17	RIN	Recommended Impedance of Analog Voltage Source	—	—	5K	Ω	(Note 1)
ADC Accuracy – Measurements with External VREF+/VREF-							
AD20c	Nr	Resolution	10 data bits			bits	—
AD21c	INL	Integral Nonlinearity	> -1	—	< 1	LSb	VINL = AVSS = VREFL = 0V, AVDD = VREFH = 3.3V
AD22c	DNL	Differential Nonlinearity	> -1	—	< 1	LSb	VINL = AVSS = VREFL = 0V, AVDD = VREFH = 3.3V (Note 2)
AD23c	GERR	Gain Error	> -1	—	< 1	LSb	VINL = AVSS = VREFL = 0V, AVDD = VREFH = 3.3V
AD24n	EOFF	Offset Error	> -1	—	< 1	LSb	VINL = AVSS = 0V, AVDD = 3.3V
AD25c	—	Monotonicity	—	—	—	—	Guaranteed

Note 1: These parameters are not characterized or tested in manufacturing.

2: With no missing codes.

3: These parameters are characterized, but not tested in manufacturing.

4: Characterized with a 1 kHz sine wave.

5: For PIC32MX534/564/664/764 devices, data provided in this table is preliminary.

TABLE 31-36: ADC MODULE SPECIFICATIONS⁽⁵⁾ (CONTINUED)

AC CHARACTERISTICS			Standard Operating Conditions: 2.3V to 3.6V (unless otherwise stated) Operating temperature -40°C ≤TA ≤+85°C for Industrial -40°C ≤TA ≤+105°C for V-Temp				
Param. No.	Symbol	Characteristics	Min.	Typical	Max.	Units	Conditions
ADC Accuracy – Measurements with Internal VREF+/VREF-							
AD20d	Nr	Resolution	10 data bits			bits	(Note 3)
AD21d	INL	Integral Nonlinearity	> -1	—	< 1	LSb	VINL = AVSS = 0V, AVDD = 2.5V to 3.6V (Note 3)
AD22d	DNL	Differential Nonlinearity	> -1	—	< 1	LSb	VINL = AVSS = 0V, AVDD = 2.5V to 3.6V (Notes 2,3)
AD23d	GERR	Gain Error	> -4	—	< 4	LSb	VINL = AVSS = 0V, AVDD = 2.5V to 3.6V (Note 3)
AD24d	EOFF	Offset Error	> -2	—	< 2	LSb	VINL = AVSS = 0V, AVDD = 2.5V to 3.6V (Note 3)
AD25d	—	Monotonicity	—	—	—	—	Guaranteed
Dynamic Performance							
AD31b	SINAD	Signal to Noise and Distortion	55	58.5	—	dB	(Notes 3,4)
AD34b	ENOB	Effective Number of Bits	9.0	9.5	—	bits	(Notes 3,4)

- Note 1:** These parameters are not characterized or tested in manufacturing.
- 2:** With no missing codes.
- 3:** These parameters are characterized, but not tested in manufacturing.
- 4:** Characterized with a 1 kHz sinewave.
- 5:** For PIC32MX534/564/664/764 devices, data provided in this table is preliminary.

PIC32MX5XX/6XX/7XX

TABLE 31-37: 10-BIT ADC CONVERSION RATE PARAMETERS⁽²⁾

Standard Operating Conditions: 2.3V to 3.6V (unless otherwise stated) Operating temperature $-40^{\circ}\text{C} \leq T_A \leq +85^{\circ}\text{C}$ for Industrial $-40^{\circ}\text{C} \leq T_A \leq +105^{\circ}\text{C}$ for V-Temp					
ADC Speed	TAD Minimum	Sampling Time Minimum	Rs Maximum	VDD	ADC Channels Configuration
1 Msps to 400 ksps ⁽¹⁾	65 ns	132 ns	500Ω	3.0V to 3.6V	
Up to 400 ksps	200 ns	200 ns	5.0 kΩ	2.5V to 3.6V	
Up to 300 ksps	200 ns	200 ns	5.0 kΩ	2.5V to 3.6V	

Note 1: External VREF- and VREF+ pins must be used for correct operation.

Note 2: These parameters are characterized, but not tested in manufacturing.

TABLE 31-38: ANALOG-TO-DIGITAL CONVERSION TIMING REQUIREMENTS

AC CHARACTERISTICS			Standard Operating Conditions: 2.3V to 3.6V (unless otherwise stated) Operating temperature -40°C ≤TA ≤+85°C for Industrial -40°C ≤TA ≤+105°C for V-Temp				
Param. No.	Symbol	Characteristics	Min.	Typical ⁽¹⁾	Max.	Units	Conditions
Clock Parameters							
AD50	TAD	Analog-to-Digital Clock Period ⁽²⁾	65	—	—	ns	See Table 31-37
Conversion Rate							
AD55	TCONV	Conversion Time	—	12 TAD	—	—	—
AD56	FCNV	Throughput Rate (Sampling Speed)	—	—	1000	ksps	AVDD = 3.0V to 3.6V
			—	—	400	ksps	AVDD = 2.5V to 3.6V
AD57	TSAMP	Sample Time	1 TAD	—	—	—	TSAMP must be ≥ 132 ns
Timing Parameters							
AD60	TPCS	Conversion Start from Sample Trigger ⁽³⁾	—	1.0 TAD	—	—	Auto-Convert Trigger (SSRC<2:0> = 111) not selected
AD61	TPSS	Sample Start from Setting Sample (SAMP) bit	0.5 TAD	—	1.5 TAD	—	—
AD62	TCSS	Conversion Completion to Sample Start (ASAM = 1) ⁽³⁾	—	0.5 TAD	—	—	—
AD63	TDPV	Time to Stabilize Analog Stage from Analog-to-Digital Off to Analog-to-Digital On ⁽³⁾	—	—	2	μs	—

- Note 1:** These parameters are characterized, but not tested in manufacturing.
- 2:** Because the sample caps will eventually lose charge, clock rates below 10 kHz can affect linearity performance, especially at elevated temperatures.
- 3:** Characterized by design but not tested.

FIGURE 31-19: ANALOG-TO-DIGITAL CONVERSION (10-BIT MODE) TIMING CHARACTERISTICS (ASAM = 0, SSRC<2:0> = 000)

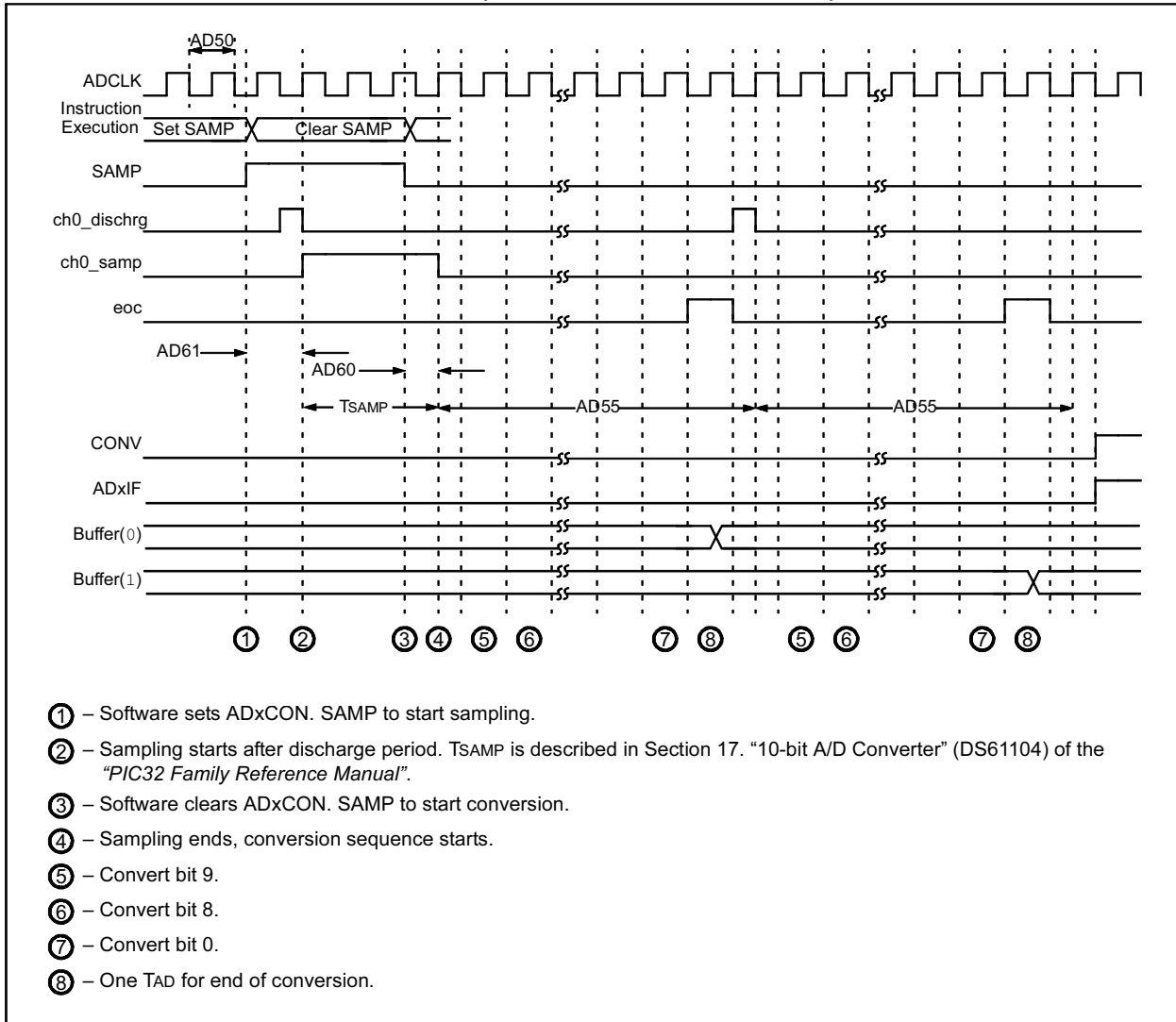

FIGURE 31-20: ANALOG-TO-DIGITAL CONVERSION (10-BIT MODE) TIMING CHARACTERISTICS
 (CHPS<1:0> = 01, ASAM = 1, SSRC<2:0> = 111, SAMC<4:0> = 00001)

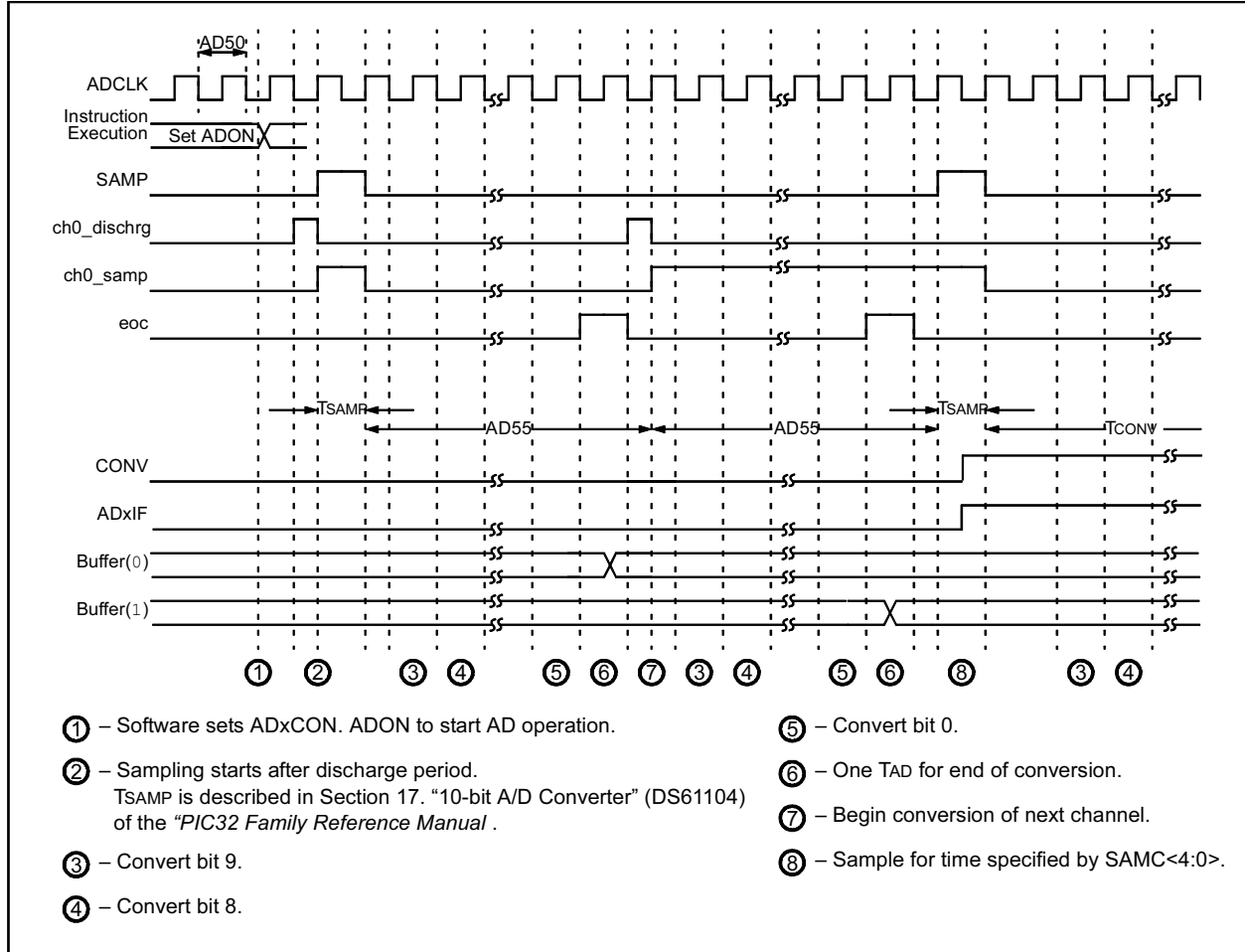

FIGURE 31-21: PARALLEL SLAVE PORT TIMING

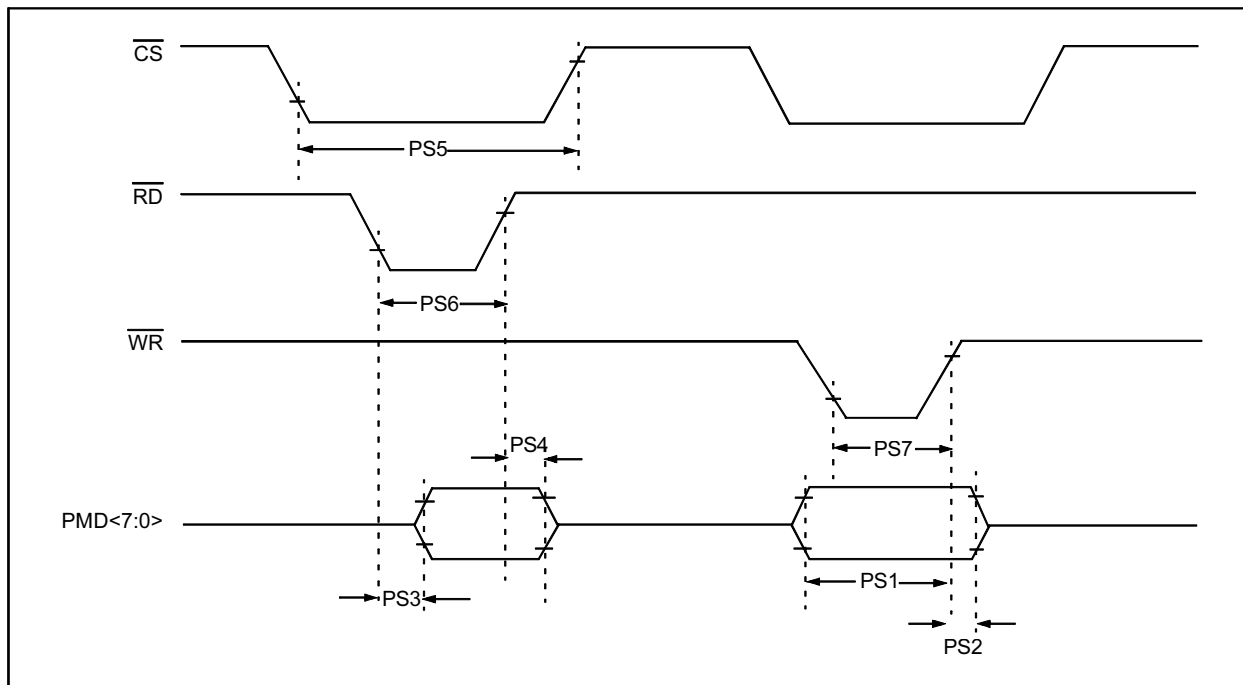

TABLE 31-39: PARALLEL SLAVE PORT REQUIREMENTS

AC CHARACTERISTICS			Standard Operating Conditions: 2.3V to 3.6V (unless otherwise stated) Operating temperature $-40^{\circ}\text{C} \leq T_A \leq +85^{\circ}\text{C}$ for Industrial $-40^{\circ}\text{C} \leq T_A \leq +105^{\circ}\text{C}$ for V-Temp				
Param. No.	Symbol	Characteristics ⁽¹⁾	Min.	Typical	Max.	Units	Conditions
PS1	TdtV2wrH	Data In Valid before \overline{WR} or \overline{CS} Inactive (setup time)	20	—	—	ns	—
PS2	TwrH2dtI	\overline{WR} or \overline{CS} Inactive to Data-In Invalid (hold time)	40	—	—	ns	—
PS3	TrdL2dtV	\overline{RD} and \overline{CS} Active to Data-Out Valid	—	—	60	ns	—
PS4	TrdH2dtI	\overline{RD} Active or \overline{CS} Inactive to Data-Out Invalid	0	—	10	ns	—
PS5	Tcs	\overline{CS} Active Time	$TPB + 40$	—	—	ns	—
PS6	TWR	\overline{WR} Active Time	$TPB + 25$	—	—	ns	—
PS7	TRD	\overline{RD} Active Time	$TPB + 25$	—	—	ns	—

Note 1: These parameters are characterized, but not tested in manufacturing.

FIGURE 31-22: PARALLEL MASTER PORT READ TIMING DIAGRAM

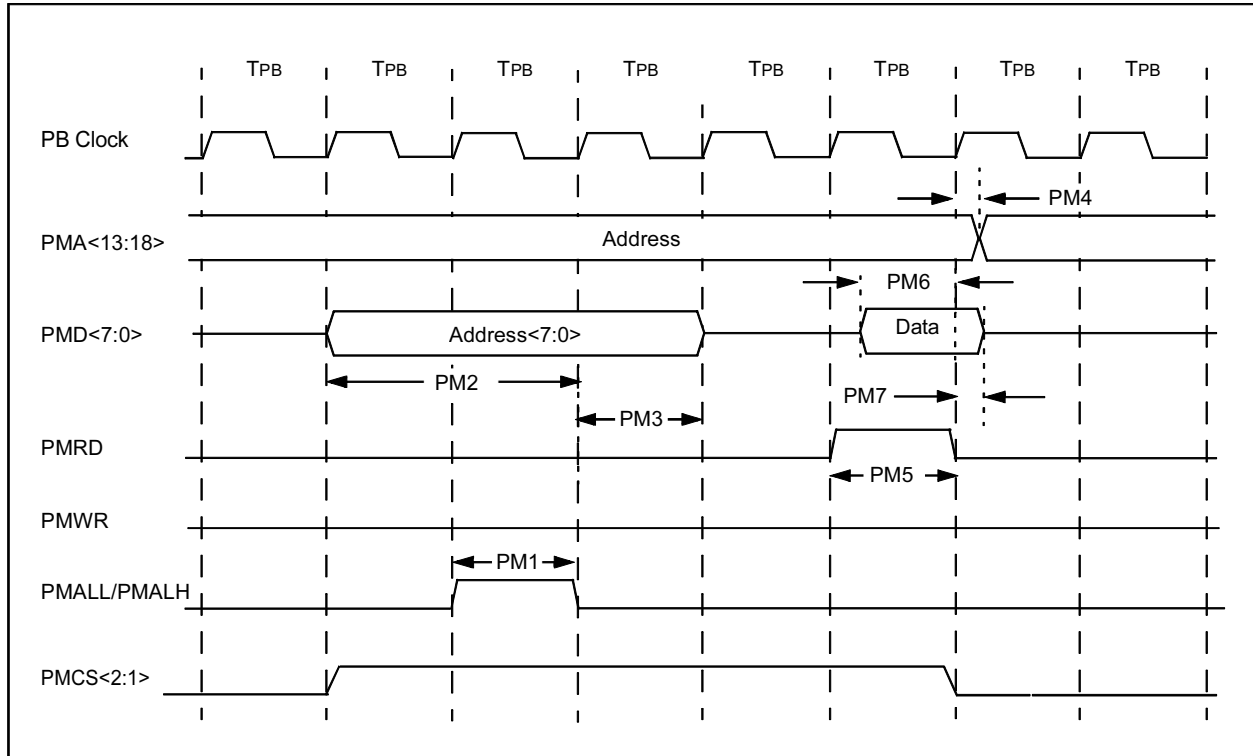

TABLE 31-40: PARALLEL MASTER PORT READ TIMING REQUIREMENTS

AC CHARACTERISTICS			Standard Operating Conditions: 2.3V to 3.6V (unless otherwise stated) Operating temperature -40°C ≤ TA ≤ +85°C for Industrial -40°C ≤ TA ≤ +105°C for V-Temp				
Param. No.	Symbol	Characteristics ⁽¹⁾	Min.	Typical	Max.	Units	Conditions
PM1	TLAT	PMALL/PMALH Pulse Width	—	1 TPB	—	—	—
PM2	TADSU	Address Out Valid to PMALL/PMALH Invalid (address setup time)	—	2 TPB	—	—	—
PM3	TADHOLD	PMALL/PMALH Invalid to Address Out Invalid (address hold time)	—	1 TPB	—	—	—
PM4	TAHOLD	PMRD Inactive to Address Out Invalid (address hold time)	5	—	—	ns	—
PM5	TRD	PMRD Pulse Width	—	1 TPB	—	—	—
PM6	TDSU	PMRD or PMENB Active to Data In Valid (data setup time)	15	—	—	ns	—
PM7	TDHOLD	PMRD or PMENB Inactive to Data In Invalid (data hold time)	—	80	—	ns	—

Note 1: These parameters are characterized, but not tested in manufacturing.

FIGURE 31-23: PARALLEL MASTER PORT WRITE TIMING DIAGRAM

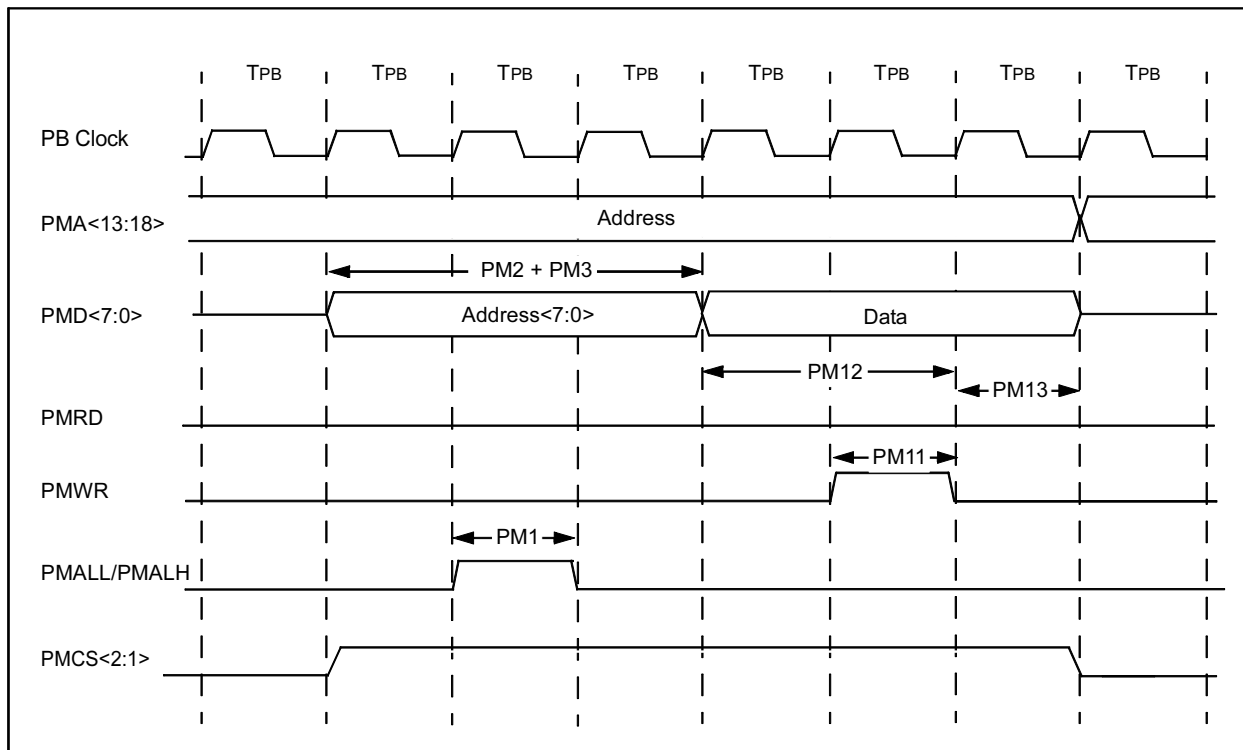

TABLE 31-41: PARALLEL MASTER PORT WRITE TIMING REQUIREMENTS

AC CHARACTERISTICS			Standard Operating Conditions: 2.3V to 3.6V (unless otherwise stated) Operating temperature $-40^{\circ}\text{C} \leq T_A \leq +85^{\circ}\text{C}$ for Industrial $-40^{\circ}\text{C} \leq T_A \leq +105^{\circ}\text{C}$ for V-Temp				
Param. No.	Symbol	Characteristics ⁽¹⁾	Min.	Typical	Max.	Units	Conditions
PM11	TWR	PMWR Pulse Width	—	1 TPB	—	—	—
PM12	Tdvsu	Data Out Valid before PMWR or PMENB goes Inactive (data setup time)	—	2 TPB	—	—	—
PM13	Tdvhld	PMWR or PMEMB Inactive to Data Out Invalid (data hold time)	—	1 TPB	—	—	—

Note 1: These parameters are characterized, but not tested in manufacturing.

TABLE 31-42: OTG ELECTRICAL SPECIFICATIONS

AC CHARACTERISTICS			Standard Operating Conditions: 2.3V to 3.6V (unless otherwise stated) Operating temperature -40°C ≤TA ≤+85°C for Industrial -40°C ≤TA ≤+105°C for V-Temp				
Param. No.	Symbol	Characteristics ⁽¹⁾	Min.	Typical	Max.	Units	Conditions
USB313	V _{USB}	USB Voltage	3.0	—	3.6	V	Voltage on V _{USB} must be in this range for proper USB operation
USB315	V _{ILUSB}	Input Low Voltage for USB Buffer	—	—	0.8	V	—
USB316	V _{IHUSB}	Input High Voltage for USB Buffer	2.0	—	—	V	—
USB318	V _{DIFS}	Differential Input Sensitivity	—	—	0.2	V	The difference between D+ and D- must exceed this value while V _{CM} is met
USB319	V _{CM}	Differential Common Mode Range	0.8	—	2.5	V	—
USB320	Z _{OUT}	Driver Output Impedance	28.0	—	44.0	Ω	—
USB321	V _{OL}	Voltage Output Low	0.0	—	0.3	V	14.25 kΩ load connected to 3.6V
USB322	V _{OH}	Voltage Output High	2.8	—	3.6	V	14.25 kΩ load connected to ground

Note 1: These parameters are characterized, but not tested in manufacturing.

FIGURE 31-24: EJTAG TIMING CHARACTERISTICS

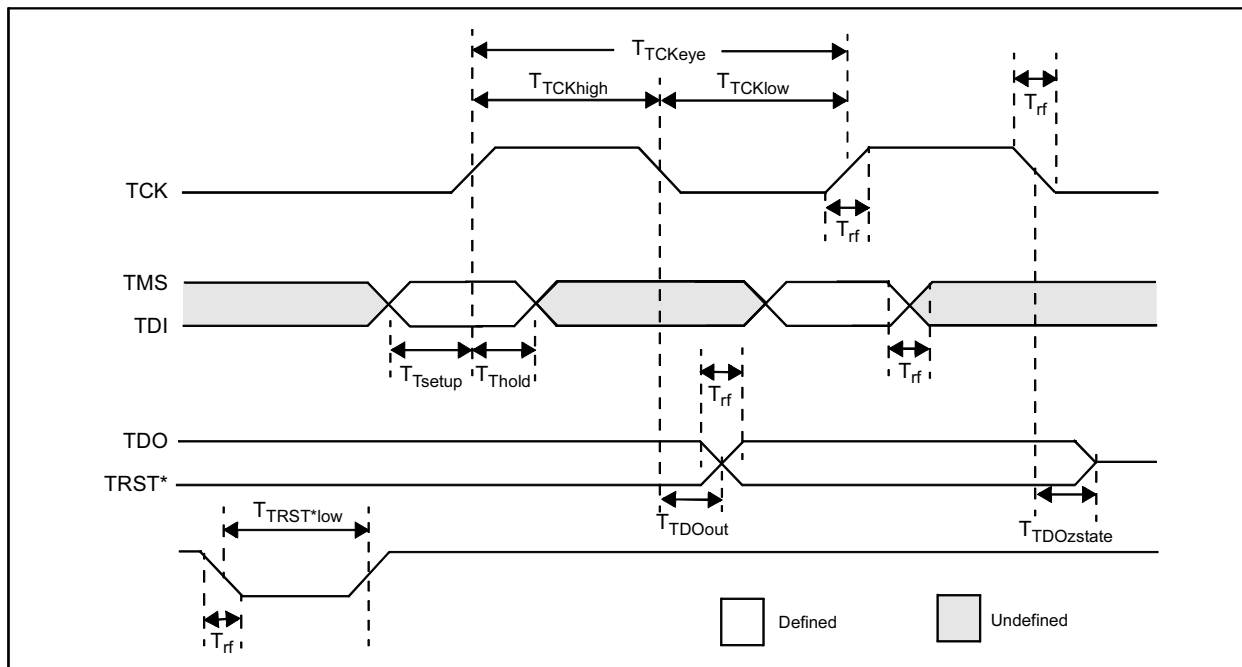

TABLE 31-43: EJTAG TIMING REQUIREMENTS

AC CHARACTERISTICS			Standard Operating Conditions: 2.3V to 3.6V (unless otherwise stated) Operating temperature $-40^{\circ}\text{C} \leq T_A \leq +85^{\circ}\text{C}$ for Industrial $-40^{\circ}\text{C} \leq T_A \leq +105^{\circ}\text{C}$ for V-Temp			
Param. No.	Symbol	Description ⁽¹⁾	Min.	Max.	Units	Conditions
EJ1	TTCKCYC	TCK Cycle Time	25	—	ns	—
EJ2	TTCKHIGH	TCK High Time	10	—	ns	—
EJ3	TTCKLOW	TCK Low Time	10	—	ns	—
EJ4	TTSETUP	TAP Signals Setup Time Before Rising TCK	5	—	ns	—
EJ5	TTHOLD	TAP Signals Hold Time After Rising TCK	3	—	ns	—
EJ6	TTDOOUT	TDO Output Delay Time from Falling TCK	—	5	ns	—
EJ7	TTDOZSTATE	TDO 3-State Delay Time from Falling TCK	—	5	ns	—
EJ8	TTRSTLOW	TRST Low Time	25	—	ns	—
EJ9	TRF	TAP Signals Rise/Fall Time, All Input and Output	—	—	ns	—

Note 1: These parameters are characterized, but not tested in manufacturing.

32.0 PACKAGING INFORMATION

32.1 Package Marking Information

64-Lead TQFP (10x10x1 mm)

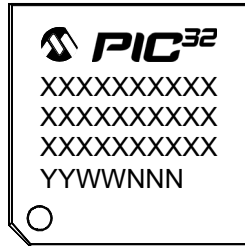

Example

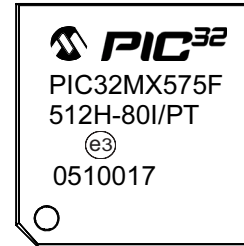

100-Lead TQFP (14x14x1 mm)



Example



100-Lead TQFP (12x12x1 mm)



Example



Legend:	XX...X	Customer-specific information
	Y	Year code (last digit of calendar year)
	YY	Year code (last 2 digits of calendar year)
	WW	Week code (week of January 1 is week '01')
	NNN	Alphanumeric traceability code
	*	Pb-free JEDEC designator for Matte Tin (Sn)
		This package is Pb-free. The Pb-free JEDEC designator (e3) can be found on the outer packaging for this package.

Note: In the event the full Microchip part number cannot be marked on one line, it will be carried over to the next line, thus limiting the number of available characters for customer-specific information.

PIC32MX5XX/6XX/7XX

32.1 Package Marking Information (Continued)

64-Lead QFN (9x9x0.9 mm)

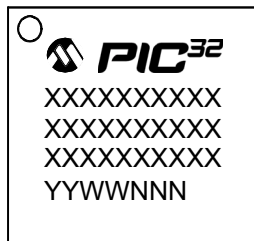

Example

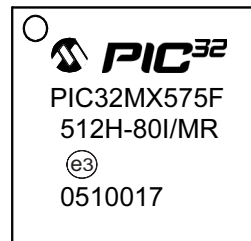

121-Lead XBGA (10x10x1.1 mm)



Example

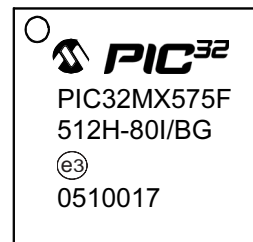

32.2 Package Details

The following sections give the technical details of the packages.

64-Lead Plastic Thin Quad Flatpack (PT) – 10x10x1 mm Body, 2.00 mm [TQFP]

Note: For the most current package drawings, please see the Microchip Packaging Specification located at <http://www.microchip.com/packaging>

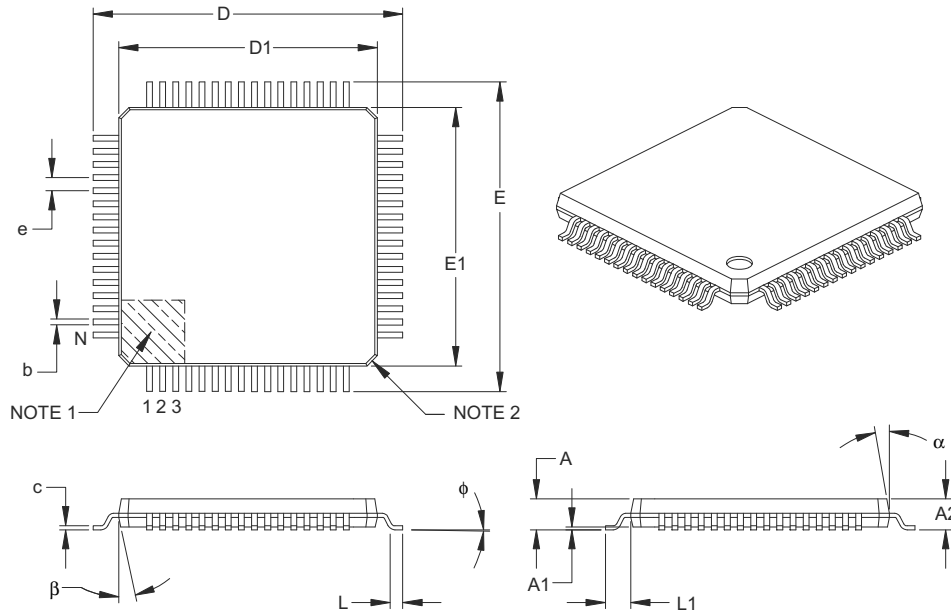

Dimension Limits	Units	MILLIMETERS		
		MIN	NOM	MAX
Number of Leads	N	64		
Lead Pitch	e	0.50 BSC		
Overall Height	A	–	–	1.20
Molded Package Thickness	A2	0.95	1.00	1.05
Standoff	A1	0.05	–	0.15
Foot Length	L	0.45	0.60	0.75
Footprint	L1	1.00 REF		
Foot Angle	ϕ	0°	3.5°	7°
Overall Width	E	12.00 BSC		
Overall Length	D	12.00 BSC		
Molded Package Width	E1	10.00 BSC		
Molded Package Length	D1	10.00 BSC		
Lead Thickness	c	0.09	–	0.20
Lead Width	b	0.17	0.22	0.27
Mold Draft Angle Top	α	11°	12°	13°
Mold Draft Angle Bottom	β	11°	12°	13°

Notes:

- Pin 1 visual index feature may vary, but must be located within the hatched area.
- Chamfers at corners are optional; size may vary.
- Dimensions D1 and E1 do not include mold flash or protrusions. Mold flash or protrusions shall not exceed 0.25 mm per side.
- Dimensioning and tolerancing per ASME Y14.5M.

BSC: Basic Dimension. Theoretically exact value shown without tolerances.

REF: Reference Dimension, usually without tolerance, for information purposes only.

Microchip Technology Drawing C04-085B

PIC32MX5XX/6XX/7XX

64-Lead Plastic Thin Quad Flatpack (PT) – 10x10x1 mm Body, 2.00 mm [TQFP]

Note: For the most current package drawings, please see the Microchip Packaging Specification located at <http://www.microchip.com/packaging>

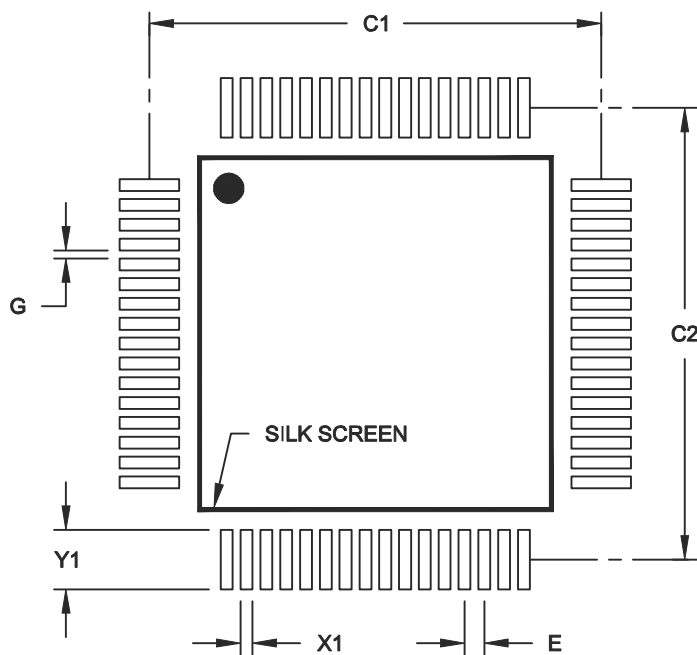

RECOMMENDED LAND PATTERN

Dimension Limits	Units	MILLIMETERS		
		MIN	NOM	MAX
Contact Pitch	E	0.50 BSC		
Contact Pad Spacing	C1		11.40	
Contact Pad Spacing	C2		11.40	
Contact Pad Width (X64)	X1			0.30
Contact Pad Length (X64)	Y1			1.50
Distance Between Pads	G	0.20		

Notes:

1. Dimensioning and tolerancing per ASME Y14.5M

BSC: Basic Dimension. Theoretically exact value shown without tolerances.

Microchip Technology Drawing No. C04-2085A

100-Lead Plastic Thin Quad Flatpack (PF) – 14x14x1 mm Body, 2.00 mm [TQFP]

Note: For the most current package drawings, please see the Microchip Packaging Specification located at <http://www.microchip.com/packaging>

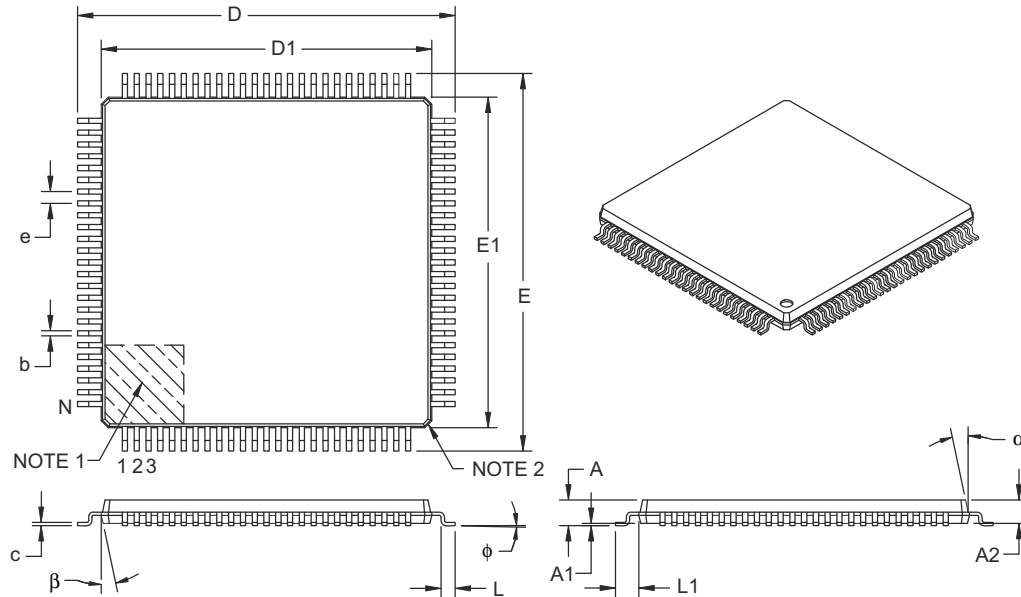

		Units	MILLIMETERS		
Dimension Limits			MIN	NOM	MAX
Number of Leads	N		100		
Lead Pitch	e		0.50 BSC		
Overall Height	A	–	–	–	1.20
Molded Package Thickness	A2		0.95	1.00	1.05
Standoff	A1		0.05	–	0.15
Foot Length	L		0.45	0.60	0.75
Footprint	L1		1.00 REF		
Foot Angle	ϕ		0°	3.5°	7°
Overall Width	E		16.00 BSC		
Overall Length	D		16.00 BSC		
Molded Package Width	E1		14.00 BSC		
Molded Package Length	D1		14.00 BSC		
Lead Thickness	c		0.09	–	0.20
Lead Width	b		0.17	0.22	0.27
Mold Draft Angle Top	α		11°	12°	13°
Mold Draft Angle Bottom	β		11°	12°	13°

Notes:

- Pin 1 visual index feature may vary, but must be located within the hatched area.
- Chamfers at corners are optional; size may vary.
- Dimensions D1 and E1 do not include mold flash or protrusions. Mold flash or protrusions shall not exceed 0.25 mm per side.
- Dimensioning and tolerancing per ASME Y14.5M.

BSC: Basic Dimension. Theoretically exact value shown without tolerances.

REF: Reference Dimension, usually without tolerance, for information purposes only.

Microchip Technology Drawing C04-110B

PIC32MX5XX/6XX/7XX

100-Lead Plastic Thin Quad Flatpack (PF) – 14x14x1 mm Body, 2.00 mm [TQFP]

Note: For the most current package drawings, please see the Microchip Packaging Specification located at <http://www.microchip.com/packaging>

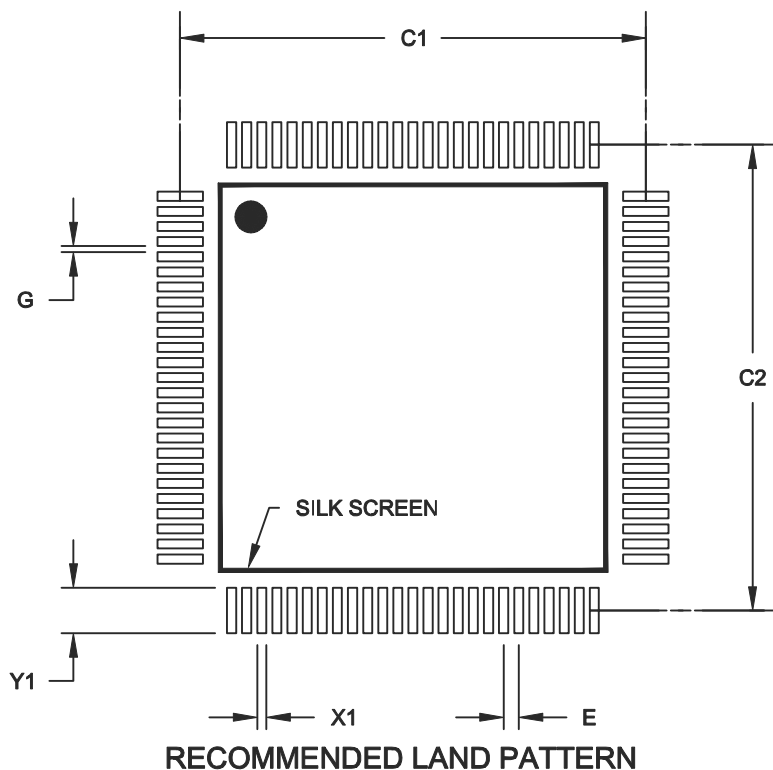

Dimension Limits	Units	MILLIMETERS		
		MIN	NOM	MAX
Contact Pitch	E	0.50 BSC		
Contact Pad Spacing	C1		15.40	
Contact Pad Spacing	C2		15.40	
Contact Pad Width (X100)	X1			0.30
Contact Pad Length (X100)	Y1			1.50
Distance Between Pads	G	0.20		

Notes:

1. Dimensioning and tolerancing per ASME Y14.5M

BSC: Basic Dimension. Theoretically exact value shown without tolerances.

Microchip Technology Drawing No. C04-2110A

100-Lead Plastic Thin Quad Flatpack (PT) – 12x12x1 mm Body, 2.00 mm [TQFP]

Note: For the most current package drawings, please see the Microchip Packaging Specification located at <http://www.microchip.com/packaging>

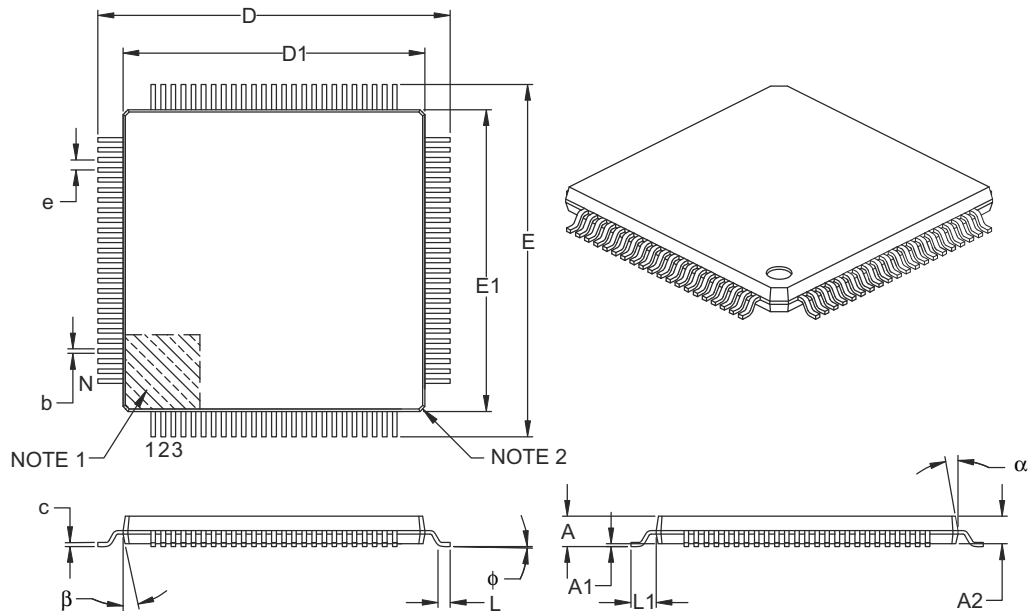

Units		MILLIMETERS		
Dimension Limits		MIN	NOM	MAX
Number of Leads	N	100		
Lead Pitch	e	0.40 BSC		
Overall Height	A	–	–	1.20
Molded Package Thickness	A2	0.95	1.00	1.05
Standoff	A1	0.05	–	0.15
Foot Length	L	0.45	0.60	0.75
Footprint	L1	1.00 REF		
Foot Angle	ϕ	0°	3.5°	7°
Overall Width	E	14.00 BSC		
Overall Length	D	14.00 BSC		
Molded Package Width	E1	12.00 BSC		
Molded Package Length	D1	12.00 BSC		
Lead Thickness	c	0.09	–	0.20
Lead Width	b	0.13	0.18	0.23
Mold Draft Angle Top	α	11°	12°	13°
Mold Draft Angle Bottom	β	11°	12°	13°

Notes:

- Pin 1 visual index feature may vary, but must be located within the hatched area.
- Chamfers at corners are optional; size may vary.
- Dimensions D1 and E1 do not include mold flash or protrusions. Mold flash or protrusions shall not exceed 0.25 mm per side.
- Dimensioning and tolerancing per ASME Y14.5M.

BSC: Basic Dimension. Theoretically exact value shown without tolerances.

REF: Reference Dimension, usually without tolerance, for information purposes only.

Microchip Technology Drawing C04-100B

PIC32MX5XX/6XX/7XX

100-Lead Plastic Thin Quad Flatpack (PT) – 12x12x1 mm Body, 2.00 mm [TQFP]

Note: For the most current package drawings, please see the Microchip Packaging Specification located at <http://www.microchip.com/packaging>

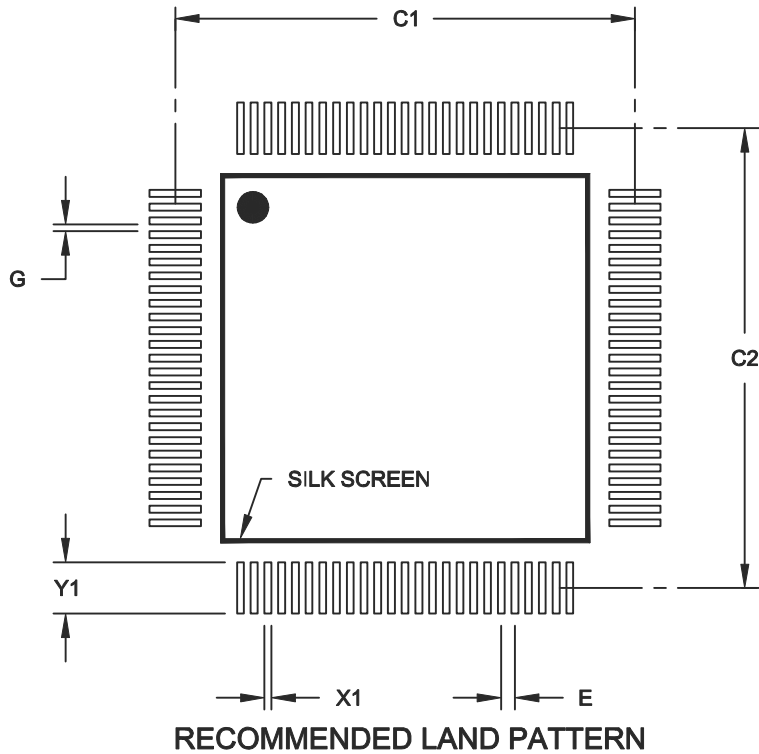

Dimension Limits	Units	MILLIMETERS		
		MIN	NOM	MAX
Contact Pitch	E	0.40 BSC		
Contact Pad Spacing	C1		13.40	
Contact Pad Spacing	C2		13.40	
Contact Pad Width (X100)	X1			0.20
Contact Pad Length (X100)	Y1			1.50
Distance Between Pads	G	0.20		

Notes:

1. Dimensioning and tolerancing per ASME Y14.5M

BSC: Basic Dimension. Theoretically exact value shown without tolerances.

Microchip Technology Drawing No. C04-2100A

64-Lead Plastic Quad Flat, No Lead Package (MR) – 9x9x0.9 mm Body [QFN] With 7.15 x 7.15 Exposed Pad [QFN]

Note: For the most current package drawings, please see the Microchip Packaging Specification located at <http://www.microchip.com/packaging>

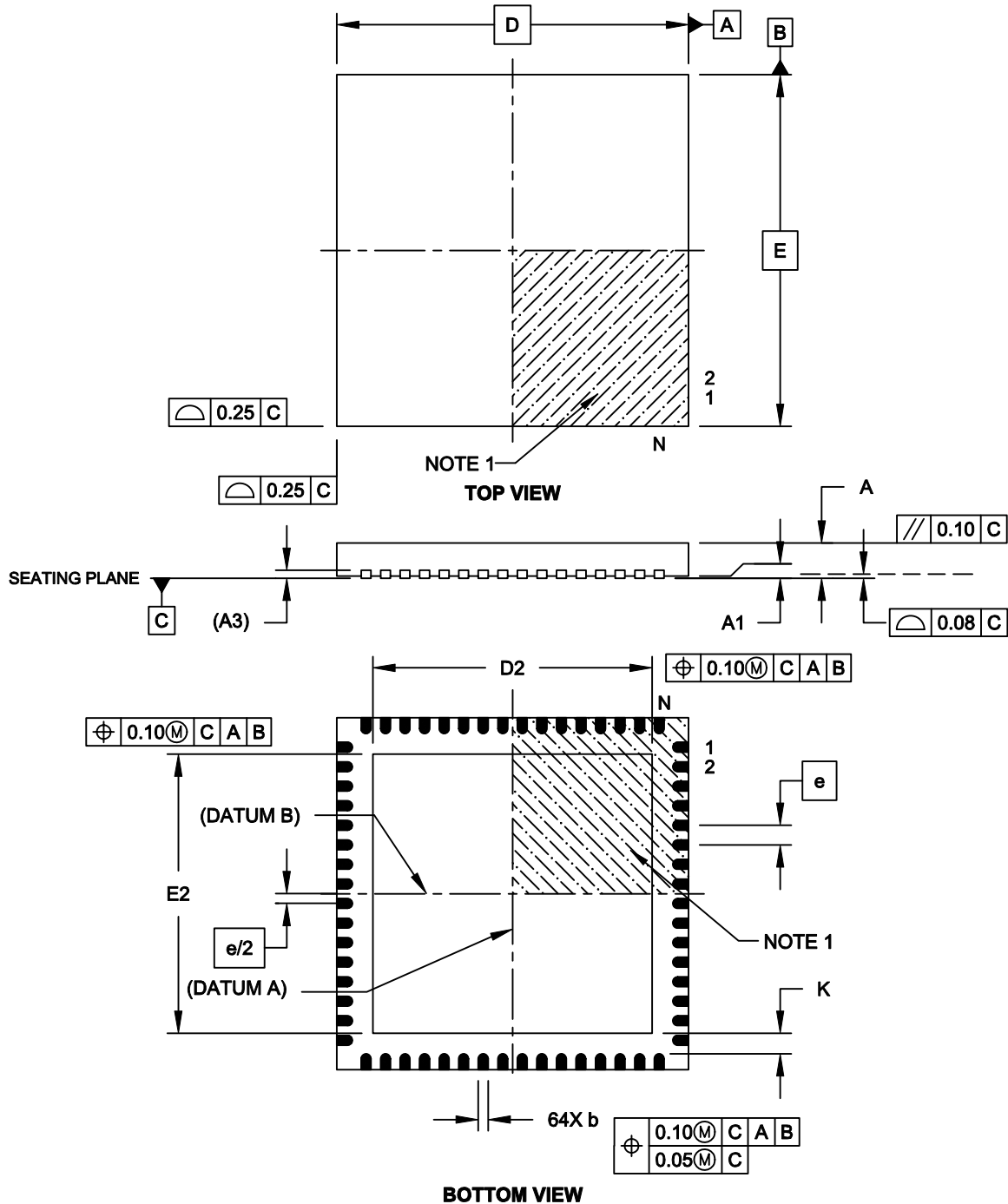

Microchip Technology Drawing C04-149C Sheet 1 of 2

PIC32MX5XX/6XX/7XX

64-Lead Plastic Quad Flat, No Lead Package (MR) – 9x9x0.9 mm Body [QFN] With 7.15 x 7.15 Exposed Pad [QFN]

Note: For the most current package drawings, please see the Microchip Packaging Specification located at <http://www.microchip.com/packaging>

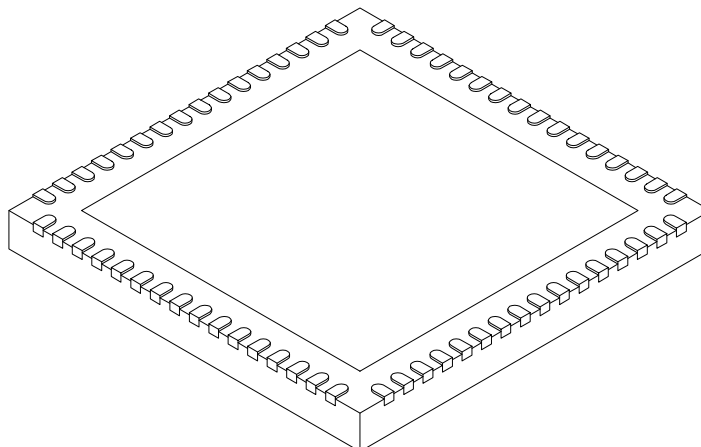

		Units	MILLIMETERS		
Dimension Limits			MIN	NOM	MAX
Number of Pins	N		64		
Pitch	e		0.50 BSC		
Overall Height	A		0.80	0.90	1.00
Standoff	A1		0.00	0.02	0.05
Contact Thickness	A3		0.20 REF		
Overall Width	E		9.00 BSC		
Exposed Pad Width	E2		7.05	7.15	7.50
Overall Length	D		9.00 BSC		
Exposed Pad Length	D2		7.05	7.15	7.50
Contact Width	b		0.18	0.25	0.30
Contact Length	L		0.30	0.40	0.50
Contact-to-Exposed Pad	K		0.20	-	-

Notes:

1. Pin 1 visual index feature may vary, but must be located within the hatched area.
2. Package is saw singulated.
3. Dimensioning and tolerancing per ASME Y14.5M.

BSC: Basic Dimension. Theoretically exact value shown without tolerances.

REF: Reference Dimension, usually without tolerance, for information purposes only.

Microchip Technology Drawing C04-149C Sheet 2 of 2

64-Lead Plastic Quad Flat, No Lead Package (MR) – 9x9x0.9 mm Body [QFN] With 0.40 mm Contact Length

Note: For the most current package drawings, please see the Microchip Packaging Specification located at <http://www.microchip.com/packaging>

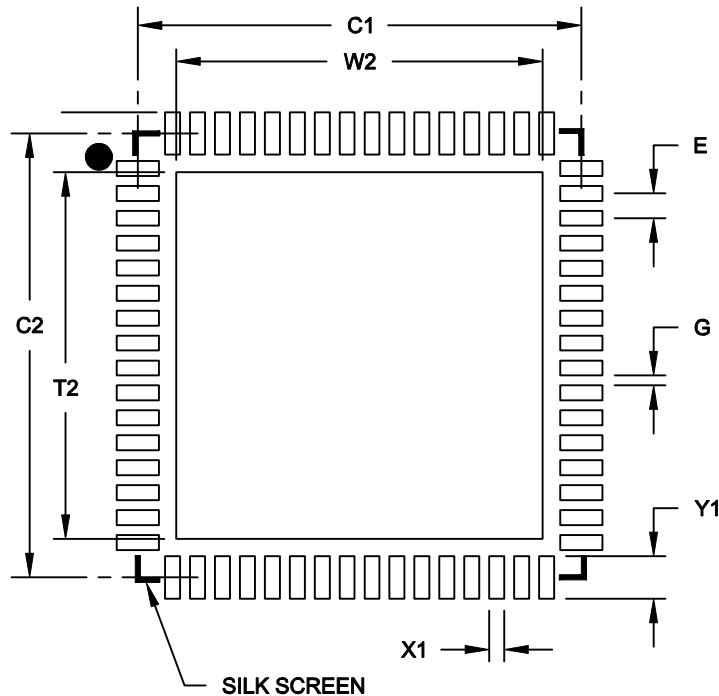

RECOMMENDED LAND PATTERN

Dimension Limits	Units	MILLIMETERS		
		MIN	NOM	MAX
Contact Pitch	E	0.50 BSC		
Optional Center Pad Width	W2			7.35
Optional Center Pad Length	T2			7.35
Contact Pad Spacing	C1		8.90	
Contact Pad Spacing	C2		8.90	
Contact Pad Width (X64)	X1			0.30
Contact Pad Length (X64)	Y1			0.85
Distance Between Pads	G	0.20		

Notes:

1. Dimensioning and tolerancing per ASME Y14.5M

BSC: Basic Dimension. Theoretically exact value shown without tolerances.

Microchip Technology Drawing No. C04-2149A

PIC32MX5XX/6XX/7XX

121-Lead Plastic Thin Profile Ball Grid Array (BG) - 10x10x1.10 mm Body [XBGA]

Note: For the most current package drawings, please see the Microchip Packaging Specification located at <http://www.microchip.com/packaging>

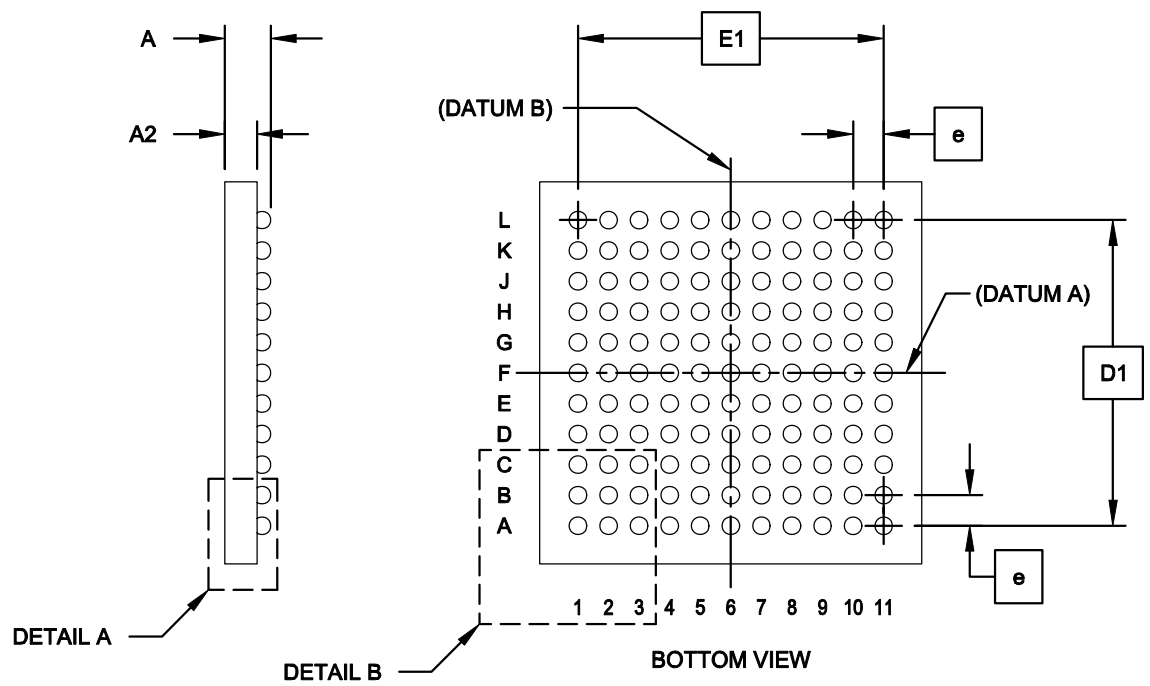
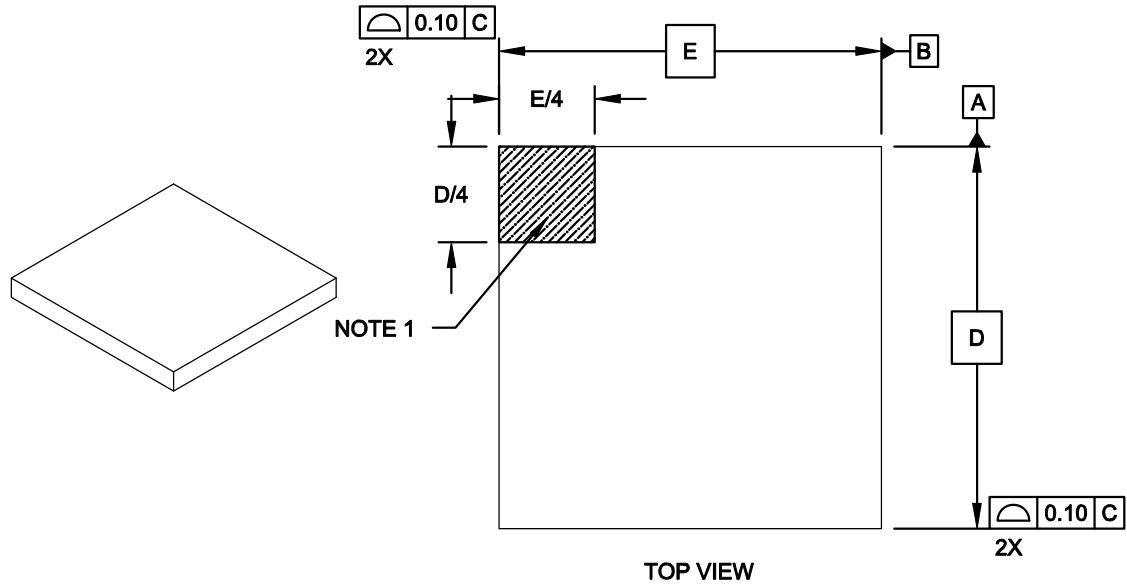

Microchip Technology Drawing C04-148A Sheet 1 of 2

121-Lead Plastic Thin Profile Ball Grid Array (BG) - 10x10x1.10 mm Body [XBGA]

Note: For the most current package drawings, please see the Microchip Packaging Specification located at <http://www.microchip.com/packaging>

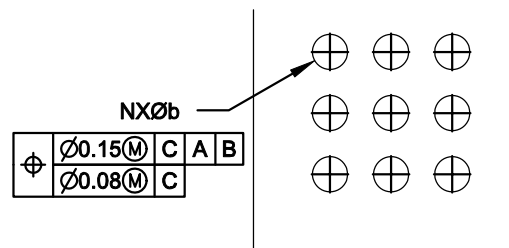
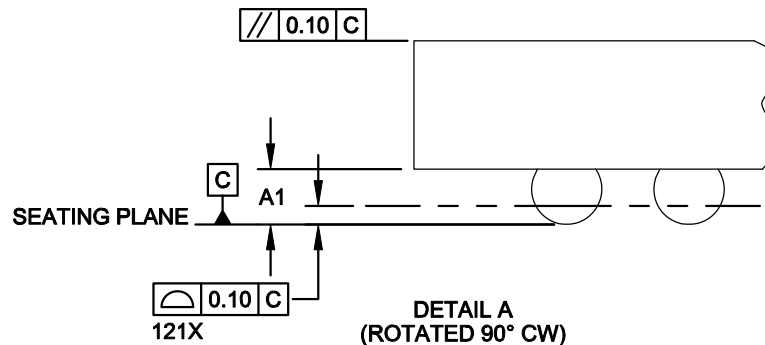

DETAIL B

	Units	MILLIMETERS		
		MIN	NOM	MAX
	Dimension Limits			
Number of Contacts	N	121		
Contact Pitch	e	0.80 BSC		
Overall Height	A	1.00	1.10	1.20
Standoff	A1	0.25	0.30	0.35
Molded Package Thickness	A2	0.55	0.60	0.65
Overall Width	E	10.00 BSC		
Array Width	E1	8.00 BSC		
Overall Length	D	10.00 BSC		
Array Length	D1	8.00 BSC		
Contact Diameter	b	0.40 TYP		

Notes:

- Pin 1 visual index feature may vary, but must be located within the hatched area.
- Dimensioning and tolerancing per ASME Y14.5M.
BSC: Basic Dimension. Theoretically exact value shown without tolerances.
REF: Reference Dimension, usually without tolerance, for information purposes only.
- The outer rows and columns of balls are located with respect to datums A and B.

Microchip Technology Drawing C04-148 Rev A Sheet 2 of 2

PIC32MX5XX/6XX/7XX

121-Lead Plastic Thin Profile Ball Grid Array (BG) - 10x10x1.10 mm Body [XBGA]

Note: For the most current package drawings, please see the Microchip Packaging Specification located at <http://www.microchip.com/packaging>

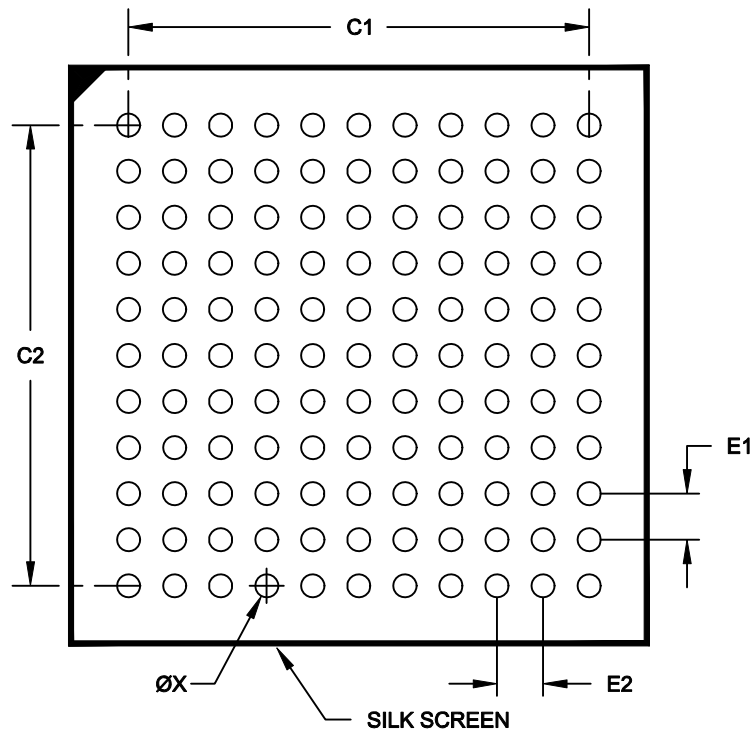

RECOMMENDED LAND PATTERN

Dimension Limits	Units	MILLIMETERS		
		MIN	NOM	MAX
Contact Pitch	E1	0.80 BSC		
Contact Pitch	E2	0.80 BSC		
Contact Pad Spacing	C1		8.00	
Contact Pad Spacing	C2		8.00	
Contact Pad Diameter (X121)	X			0.40

Notes:

1. Dimensioning and tolerancing per ASME Y14.5M

BSC: Basic Dimension. Theoretically exact value shown without tolerances.

Microchip Technology Drawing No. C04-2148A

APPENDIX A: MIGRATING FROM PIC32MX3XX/4XX TO PIC32MX5XX/6XX/7XX DEVICES

This appendix provides an overview of considerations for migrating from PIC32MX3XX/4XX devices to the PIC32MX5XX/6XX/7XX family of devices. The code developed for the PIC32MX3XX/4XX devices can be ported to the PIC32MX5XX/6XX/7XX devices after making the appropriate changes outlined below.

A.1 DMA

PIC32MX5XX/6XX/7XX devices do not support stopping DMA transfers in Idle mode.

A.2 Interrupts

PIC32MX5XX/6XX/7XX devices have persistent interrupts for some of the peripheral modules. This means that the interrupt condition for these peripherals must be cleared before the interrupt flag can be cleared.

For example, to clear a UART receive interrupt, the user application must first read the UART Receive register to clear the interrupt condition and then clear the associated UxIF flag to clear the pending UART interrupt. In other words, the UxIF flag cannot be cleared by software until the UART Receive register is read.

Table A-1 outlines the peripherals and associated interrupts that are implemented differently on PIC32MX5XX/6XX/7XX versus PIC32MX3XX/4XX devices.

In addition, on the SPI module, the IRQ numbers for the receive done interrupts were changed from 25 to 24 and the transfer done interrupts were changed from 24 to 25.

TABLE A-1: PIC32MX3XX/4XX VERSUS PIC32MX5XX/6XX/7XX INTERRUPT IMPLEMENTATION DIFFERENCES

Module	Interrupt Implementation
Input Capture	To clear an interrupt source, read the Buffer Result (ICxBUF) register to obtain the number of capture results in the buffer that are below the interrupt threshold (specified by ICI<1:0> bits).
SPI	Receive and transmit interrupts are controlled by the SRXISEL<1:0> and STXISEL<1:0> bits, respectively. To clear an interrupt source, data must be written to, or read from, the SPIxBUF register to obtain the number of data to receive/transmit below the level specified by the SRXISEL<1:0> and STXISEL<1:0> bits.
UART	TX interrupt will be generated as soon as the UART module is enabled. Receive and transmit interrupts are controlled by the URXISEL<1:0> and UTXISEL<1:0> bits, respectively. To clear an interrupt source, data must be read from, or written to, the UxRXREG or UxTXREG registers to obtain the number of data to receive/transmit below the level specified by the URXISEL<1:0> and UTXISEL<1:0> bits.
ADC	All samples must be read from the result registers (ADC1BUFx) to clear the interrupt source.
PMP	To clear an interrupt source, read the Parallel Master Port Data Input/Output (PMDIN/PMDOUT) register.

APPENDIX B: REVISION HISTORY

Revision B (November 2009)

Revision A (August 2009)

This is the initial released version of this document.

The revision includes the following global update:

- Added Note 2 to the shaded table that appears at the beginning of each chapter. This new note provides information regarding the availability of registers and their associated bits.

Other major changes are referenced by their respective chapter/section in [Table B-1](#).

TABLE B-1: MAJOR SECTION UPDATES

Section Name	Update Description
<p>“High-Performance, USB, CAN and Ethernet 32-bit Flash Microcontrollers”</p>	<p>Added the following devices:</p> <ul style="list-style-type: none"> - PIC32MX575F256L - PIC32MX695F512L - PIC32MX695F512H <p>The 100-pin TQFP pin diagrams have been updated to reflect the current pin name locations (see the “Pin Diagrams” section).</p> <p>Added the 121-pin Ball Grid Array (XBGA) pin diagram.</p> <p>Updated Table 1: “PIC32 USB and CAN – Features”</p> <p>Added the following tables:</p> <ul style="list-style-type: none"> - Table 4: “Pin Names: PIC32MX534F064L, PIC32MX564F064L, PIC32MX564F128L, PIC32MX575F256L and PIC32MX575F512L Devices” - Table 5: “Pin Names: PIC32MX664F064L, PIC32MX664F128L, PIC32MX675F256L, PIC32MX675F512L and PIC32MX695F512L Devices” - Table 6: “Pin Names: PIC32MX775F256L, PIC32MX775F512L and PIC32MX795F512L Devices” <p>Updated the following pins as 5V tolerant:</p> <ul style="list-style-type: none"> - 64-pin QFN: Pin 36 (D-/RG3) and Pin 37 (D+/RG2) - 64-pin TQFP: Pin 36 (D-/RG3) and Pin 37 (D+/RG2) - 100-pin TQFP: Pin 56 (D-/RG3) and Pin 57 (D+/RG2)
<p>2.0 “Guidelines for Getting Started with 32-bit Microcontrollers”</p>	<p>Removed the last sentence of 2.3.1 “Internal Regulator Mode”.</p> <p>Removed Section 2.3.2 “External Regulator Mode”</p>

TABLE B-1: MAJOR SECTION UPDATES (CONTINUED)

Section Name	Update Description
<p>4.0 “Memory Organization”</p>	<p>Updated all register tables to include the Virtual Address and All Resets columns.</p> <p>Updated the title of Figure 4-4 to include the PIC32MX575F256L device.</p> <p>Updated the title of Figure 4-6 to include the PIC32MX695F512L and PIC32MX695F512H devices. Also changed PIC32MX795F512L to PIC32MX795F512H.</p> <p>Updated the title of Table 4-3 to include the PIC32MX695F512H device.</p> <p>Updated the title of Table 4-5 to include the PIC32MX575F256L device.</p> <p>Updated the title of Table 4-6 to include the PIC32MX695F512L device.</p> <p>Reversed the order of Table 4-11 and Table 4-12.</p> <p>Reversed the order of Table 4-14 and Table 4-15.</p> <p>Updated the title of Table 4-15 to include the PIC32MX575F256L and PIC32MX695F512L devices.</p> <p>Updated the title of Table 4-45 to include the PIC32MX575F256L device.</p> <p>Updated the title of Table 4-47 to include the PIC32MX695F512H and PIC32MX695F512L devices.</p>
<p>12.0 “I/O Ports”</p>	<p>Updated the second paragraph of 12.1.2 “Digital Inputs” and removed Table 12-1.</p>
<p>22.0 “10-bit Analog-to-Digital Converter (ADC)”</p>	<p>Updated the ADC Conversion Clock Period Block Diagram (see Figure 22-2).</p>
<p>28.0 “Special Features”</p>	<p>Removed references to the ENVREG pin in 28.3 “On-Chip Voltage Regulator”.</p> <p>Updated the first sentence of 28.3.1 “On-Chip Regulator and POR” and 28.3.2 “On-Chip Regulator and BOR”.</p> <p>Updated the Connections for the On-Chip Regulator (see Figure 28-2).</p>
<p>31.0 “Electrical Characteristics”</p>	<p>Updated the Absolute Maximum Ratings and added Note 3.</p> <p>Added Thermal Packaging Characteristics for the 121-pin XBGA package (see Table 31-3).</p> <p>Updated the Operating Current (IDD) DC Characteristics (see Table 31-5).</p> <p>Updated the Idle Current (IIDL) DC Characteristics (see Table 31-6).</p> <p>Updated the Power-Down Current (IPD) DC Characteristics (see Table 31-7).</p> <p>Removed Note 1 from the Program Flash Memory Wait State Characteristics (see Table 31-12).</p> <p>Updated the SPIx Module Slave Mode (CKE = 1) Timing Characteristics, changing SP52 to SP35 between the MSb and Bit 14 on SDOx (see Figure 31-13).</p>
<p>32.0 “Packaging Information”</p>	<p>Added the 121-pin XBGA package marking information and package details.</p>
<p>“Product Identification System”</p>	<p>Added the definition for BG (121-lead 10x10x1.1 mm, XBGA).</p> <p>Added the definition for Speed.</p>

PIC32MX5XX/6XX/7XX

Revision C (February 2010)

The revision includes the following updates, as described in [Table B-2](#):

TABLE B-2: MAJOR SECTION UPDATES

Section Name	Update Description																								
“High-Performance, USB, CAN and Ethernet 32-bit Flash Microcontrollers”	<p>Added the following devices:</p> <ul style="list-style-type: none"> • PIC32MX675F256H • PIC32MX775F256H • PIC32MX775F512H • PIC32MX675F256L • PIC32MX775F256L • PIC32MX775F512L <p>Added the following pins:</p> <ul style="list-style-type: none"> • EREFCLK • ECRSDV • AEREFCLK • AECRSDV <p>Added the EREFCLK and ECRSDV pins to Table 5 and Table 6.</p>																								
1.0 “Device Overview”	<p>Updated the pin number pinout I/O descriptions for the following pin names in Table 1-1:</p> <table style="width: 100%; border: none;"> <tr> <td style="width: 25%;">• SCL3</td> <td style="width: 25%;">• SCL5</td> <td style="width: 25%;">• RTCC</td> <td style="width: 25%;">• C1OUT</td> </tr> <tr> <td>• SDA3</td> <td>• SDA5</td> <td>• CVREF-</td> <td>• C2IN-</td> </tr> <tr> <td>• SCL2</td> <td>• TMS</td> <td>• CVREF+</td> <td>• C2IN+</td> </tr> <tr> <td>• SDA2</td> <td>• TCK</td> <td>• CVREFOUT</td> <td>• C2OUT</td> </tr> <tr> <td>• SCL4</td> <td>• TDI</td> <td>• C1IN-</td> <td>• PMA0</td> </tr> <tr> <td>• SDA4</td> <td>• TDO</td> <td>• C1IN+</td> <td>• PMA1</td> </tr> </table> <p>Added the following pins to the Pinout I/O Descriptions table (Table 1-1):</p> <ul style="list-style-type: none"> • EREFCLK • ECRSDV • AEREFCLK • AECRSDV 	• SCL3	• SCL5	• RTCC	• C1OUT	• SDA3	• SDA5	• CVREF-	• C2IN-	• SCL2	• TMS	• CVREF+	• C2IN+	• SDA2	• TCK	• CVREFOUT	• C2OUT	• SCL4	• TDI	• C1IN-	• PMA0	• SDA4	• TDO	• C1IN+	• PMA1
• SCL3	• SCL5	• RTCC	• C1OUT																						
• SDA3	• SDA5	• CVREF-	• C2IN-																						
• SCL2	• TMS	• CVREF+	• C2IN+																						
• SDA2	• TCK	• CVREFOUT	• C2OUT																						
• SCL4	• TDI	• C1IN-	• PMA0																						
• SDA4	• TDO	• C1IN+	• PMA1																						
4.0 “Memory Organization”	<p>Added new devices and updated the virtual and physical memory map values in Figure 4-4.</p> <p>Added new devices to Figure 4-5.</p> <p>Added new devices to the following register maps:</p> <ul style="list-style-type: none"> • Table 4-3, Table 4-4, Table 4-6 and Table 4-7 (Interrupt Register Maps) • Table 4-12 (I2C2 Register Map) • Table 4-15 (SPI1 Register Map) • Table 4-24 through Table 4-35 (PORTA-PORTG Register Maps) • Table 4-36 and Table 4-37 (Change Notice and Pull-up Register Maps) • Table 4-45 (CAN1 Register Map) • Table 4-46 (CAN2 Register Map) • Table 4-47 (Ethernet Controller Register Map) <p>Changed the bits named POSCMD to POSCMOD in Table 4-42 (Device Configuration Word Summary).</p>																								
28.0 “Special Features”	<p>Changed all references of POSCMD to POSCMOD in the Device Configuration Word 1 register (see Register 28-2).</p>																								
Appendix A: “Migrating from PIC32MX3XX/4XX to PIC32MX5XX/6XX/7XX Devices”	<p>Added the new section Appendix .</p>																								

Revision D (May 2010)

The revision includes the following updates, as described in [Table B-3](#):

TABLE B-3: MAJOR SECTION UPDATES

Section Name	Update Description
<p>“High-Performance, USB, CAN and Ethernet 32-bit Flash Microcontrollers”</p>	<p>Updated the initial Flash memory range to 64K.</p> <p>Updated the initial SRAM memory range to 16K.</p> <p>Added the following devices (see Table 1, Table 2, Table 3 and the Pin Diagrams):</p> <ul style="list-style-type: none"> • PIC32MX534F064H • PIC32MX564F064H • PIC32MX664F064H • PIC32MX564F128H • PIC32MX664F128H • PIC32MX764F128H • PIC32MX534F064L • PIC32MX564F064L • PIC32MX664F064L • PIC32MX564F128L • PIC32MX664F128L • PIC32MX764F128L
<p>4.0 “Memory Organization”</p>	<p>Added new Memory Maps (Figure 4-1, Figure 4-2 and Figure 4-3).</p> <p>The bit named I2CSIF was changed to I2C1SIF and the bit named I2CBIF was changed to I2C1BIF in the Interrupt Register Map tables (Table 4-2, Table 4-3, Table 4-4, Table 4-5, Table 4-6 and Table 4-7)</p> <p>Added the following devices to the Interrupt Register Map (Table 4-2):</p> <ul style="list-style-type: none"> • PIC32MX534F064H • PIC32MX564F064H • PIC32MX564F128H <p>Added the following devices to the Interrupt Register Map (Table 4-3):</p> <ul style="list-style-type: none"> • PIC32MX664F064H • PIC32MX664F128H <p>Added the following device to the Interrupt Register Map (Table 4-4):</p> <ul style="list-style-type: none"> • PIC32MX764F128H <p>Added the following devices to the Interrupt Register Map (Table 4-5):</p> <ul style="list-style-type: none"> • PIC32MX534F064L • PIC32MX564F064L • PIC32MX564F128L <p>Added the following devices to the Interrupt Register Map (Table 4-6):</p> <ul style="list-style-type: none"> • PIC32MX664F064L • PIC32MX664F128L <p>Added the following device to the Interrupt Register Map (Table 4-7):</p> <ul style="list-style-type: none"> • PIC32MX764F128L

PIC32MX5XX/6XX/7XX

TABLE B-3: MAJOR SECTION UPDATES (CONTINUED)

Section Name	Update Description
<p>4.0 “Memory Organization” (Continued)</p>	<p>Made the following bit name changes in the I2C1, I2C3, I2C4 and I2C5 Register Map (Table 4-11):</p> <ul style="list-style-type: none"> • I2C3BRG SFR: I2C1BRG was changed to I2C3BRG • I2C4BRG SFR: I2C1BRG was changed to I2C4BRG • I2C5BRG SFR: I2C1BRG was changed to I2C5BRG • I2C4TRN SFR: I2CT1DATA was changed to I2CT2ADATA • I2C4RCV SFR: I2CR2DATA was changed to I2CR2ADATA • I2C5TRN SFR: I2CT1DATA was changed to I2CT3ADATA • I2C5RCV SFR: I2CR1DATA was changed to I2CR3ADATA <p>Added the RTSMD bit and UEN<1:0> bits to the UART1A, UART1B, UART2A, UART2B, UART3A and UART3B Register Map (Table 4-13)</p> <p>Added the SIDL bit to the DMA Global Register Map (Table 4-17).</p> <p>Changed the CM bit to CMR in the System Control Register Map (Table 4-23).</p> <p>Added the following devices to the I2C2, SPI1, PORTA, PORTC, PORTD, PORTE, PORTF, PORTG, Change Notice and Pull-up Register Maps (Table 4-12, Table 4-14, Table 4-24, Table 4-27, Table 4-29, Table 4-31, Table 4-33, Table 4-35 and Table 4-36):</p> <ul style="list-style-type: none"> • PIC32MX534F064L • PIC32MX564F064L • PIC32MX564F128L • PIC32MX664F064L • PIC32MX664F128L • PIC32MX764F128L <p>Added the following devices to the PORTC, PORTD, PORTE, PORTF, PORTG, Change Notice and Pull-up Register Maps (Table 4-26, Table 4-28, Table 4-30, Table 4-32, Table 4-34 and Table 4-37):</p> <ul style="list-style-type: none"> • PIC32MX534F064H • PIC32MX564F064H • PIC32MX564F128H • PIC32MX664F064H • PIC32MX664F128H • PIC32MX764F128H <p>Added the following devices to the CAN1 Register Map (Table 4-45):</p> <ul style="list-style-type: none"> • PIC32MX534F064H • PIC32MX564F064H • PIC32MX564F128H • PIC32MX764F128H • PIC32MX534F064L • PIC32MX564F064L • PIC32MX564F128L • PIC32MX764F128L <p>Added the following devices to the Ethernet Controller Register Map (Table 4-47):</p> <ul style="list-style-type: none"> • PIC32MX664F064H • PIC32MX664F128H • PIC32MX764F128H • PIC32MX664F064L • PIC32MX664F128L • PIC32MX764F128L

TABLE B-3: MAJOR SECTION UPDATES (CONTINUED)

Section Name	Update Description
31.0 “Electrical Characteristics”	Updated the Typical and Maximum DC Characteristics: Operating Current (IDD) in Table 31-5 . Updated the Typical and Maximum DC Characteristics: Idle Current (IDLE) in Table 31-6 . Updated the Typical and Maximum DC Characteristics: Power-Down Current (IPD) in Table 31-7 . Added DC Characteristics: Program Memory parameters D130a and D132a in Table 31-11 . Added the Internal Voltage Reference parameter (D305) to the Comparator Specifications in Table 31-13 .

Revision E (July 2010)

Minor corrections were incorporated throughout the document.

Revision F (December 2010)

The revision includes the following global update:

VCAP/VDDCORE has been changed to: VCAP/VCORE

Other major changes are referenced by their respective chapter/section in [Table B-4](#):

TABLE B-4: SECTION UPDATES

Section Name	Update Description
High-Performance, USB, CAN and Ethernet 32-bit Flash Microcontrollers	Removed the following Analog Feature: FV tolerant input pins (digital pins only) Updated the term LIN 1.2 support as LIN support for the peripheral feature: Six UART modules with: RS-232, RS-485, and LIN support
1.0 “Device Overview”	Updated the value of 64-pin QFN/TQFP pin number for the following pin names: PMA0, PMA1 and ECRSDV
4.0 “Memory Organization”	The following register map tables were updated: <ul style="list-style-type: none"> • Table 4-2: <ul style="list-style-type: none"> - Changed bits 24/8 to I2C5BIF in IFS1 - Changed bits 24/8-24/10 to SRIPL<2:0> in INTSTAT - Changed bits 25/9/-24/8 to U5IS<1:0> in IPC12 - Added note 2 • Table 4-3 through Table 4-7: <ul style="list-style-type: none"> - Changed bits 24/8-24/10 to SRIPL<2:0> in INTSTAT - Changed bits 25/9-24/8 to U5IS<1:0> in IPC12 • Table 4-3: <ul style="list-style-type: none"> - Changed bits 24/8 to I2C5BIF in IFS1 - Added note 2 • Table 4-4: <ul style="list-style-type: none"> - Changed bits 24/8 to I2C5BIF in IFS1 - Changed bits 24/8 to I2C5BIE in IEC1 - Added note 2 references • Table 4-5: <ul style="list-style-type: none"> - Changed bits 24/8 to I2C5BIF in IFS1 - Changed bits 24/8 to I2C5BIE in IEC1 - Added note 2 references • Table 4-6: <ul style="list-style-type: none"> - Changed bit 24/8 to I2C5BIF in IFS1 - Updated the bit value of bit 24/8 as I2C5BIE for the IEC1 register. - Added note 2 • Table 4-7: <ul style="list-style-type: none"> - Changed bit 25/9 to I2C5SIF in IFS1 - Changed bit 24/8 as I2C5BIF in IFS1 - Changed bit 25/9 as I2C5SIE in IEC1 - Changed bit 24/8 as I2C5BIE in IEC1 - Added note 2 references • Added note 2 to Table 4-8 • Updated the All Resets values for the following registers in Table 4-11: I2C3CON, I2C4CON, I2C5CON and I2C1CON. • Updated the All Resets values for the I2C2CON register in Table 4-12

TABLE B-4: SECTION UPDATES (CONTINUED)

Section Name	Update Description
<p>4.0 "Memory Organization" (Continued)</p>	<ul style="list-style-type: none"> • Table 4-13: <ul style="list-style-type: none"> - Changed register U4RG to U1BRG - Changed register U5RG to U3BRG - Changed register U6RG to U2BRG • Table 4-14: <ul style="list-style-type: none"> - Updated the All Resets values for the following registers: SPI3STAT, SPI2STAT and SPI4STAT • Table 4-15: Updated the All Resets values for the SPI1STAT register • Table 4-17: Added note 2 • Table 4-19: Added note 2 • Table 4-20: Updated the All Resets values for the CM1CON and CM2CON registers • Table 4-21: <ul style="list-style-type: none"> - Updated the All Resets values as 0000 for the CVRCON register - Updated note 2 • Table 4-38: Updated the All Resets values for the PMSTAT register • Table 4-40: Updated the All Resets values for the CHECON and CHETAG registers • Table 4-42: Updated the bit value of bit 29/13 as '—' for the DEVCFG3 register • Table 4-44: <ul style="list-style-type: none"> - Updated the note references in the entire table - Changed existing note 1 to note 4 - Added notes 1, 2 and 3 - Changed bits 23/7 in U1PWRC to UACTPND - Changed register U1DDR to U1ADDR - Changed register U4DTP1 to U1BDTP1 - Changed register U4DTP2 to U1BDTP2 - Changed register U4DTP3 to U1BDTP3 • Table 4-45: <ul style="list-style-type: none"> - Updated the All Resets values for the C1CON and C1VEC registers - Changed bits 30/14 in C1CON to FRZ - Changed bits 27/11 in C1CON to CANBUSY - Changed bits 22/6-16/0 in C1VEC to ICODE<6:0> - Changed bits 22/6-16/0 in C1TREC to RERRCNT<7:0> - Changed bits 31/15-24/8 in C1TREC to TERRCNT<7:0> • Table 4-46: <ul style="list-style-type: none"> - Updated the All Resets values for the C2CON and C2VEC registers - Changed bits 30/14 in C1CON to FRZ - Changed bits 27/11 in C1CON to CANBUSY - Changed bits 22/6-16/0 in C1VEC register to ICODE<6:0> - Changed bits 22/6-16/0 in C1TREC register to RERRCNT<7:0> - Changed bits 31/15-24/8 in C1TREC to TERRCNT<7:0>

TABLE B-4: SECTION UPDATES (CONTINUED)

Section Name	Update Description
<p>7.0 “Interrupt Controller”</p>	<ul style="list-style-type: none"> • Updated the following Interrupt Sources in Table 7-1: <ul style="list-style-type: none"> - Changed IC2AM – I2C4 Master Event to: IC4M – I2C4 Master Event - Changed IC3AM – I2C5 Master Event to: IC5M – I2C4 Master Event - Changed U1E – UART1A Error to: U1E – UART1 Error - Changed U4E – UART1B Error to: U4E – UART4 Error - Changed U1RX – UART1A Receiver to: U1RX – UART1 Receiver - Changed U4RX – UART1B Receiver to: U4RX – UART4 Receiver - Changed U1TX – UART1A Transmitter to: U1TX – UART1 Transmitter - Changed U4TX – UART1B Transmitter to: U4TX – UART4 Transmitter - Changed U6E – UART2B Error to: U6E – UART6 Error - Changed U6RX – UART2B Receiver to: U6RX – UART6 Receiver - Changed U6TX – UART2B Transmitter to: U6TX – UART6 Transmitter - Changed U5E – UART3B Error to: U5E – UART5 Error - Changed U5RX – UART3B Receiver to: U5RX – UART5 Receiver - Changed U5TX – UART3B Transmitter to: U5TX – UART5 Transmitter
<p>8.0 “Oscillator Configuration”</p>	<p>Updated Figure 8-1</p>
<p>16.0 “Output Compare”</p>	<p>Updated Figure 16-1</p>
<p>24.0 “Ethernet Controller”</p>	<p>Added a note on using the Ethernet controller pins (see note above Table 24-3)</p>
<p>26.0 “Comparator Voltage Reference (CVREF)”</p>	<p>Updated the note in Figure 26-1</p>
<p>28.0 “Special Features”</p>	<p>Updated the bit description for bit 10 in Register 28-2</p> <p>Added notes 1 and 2 to Register 28-4</p>
<p>31.0 “Electrical Characteristics”</p>	<p>Updated the Absolute Maximum Ratings:</p> <ul style="list-style-type: none"> • Voltage on any 5V tolerant pin with respect to Vss when VDD < 2.3V - 0.3V to +3.6V was updated • Voltage on VBUS with respect to Vss - 0.3V to +5.5V was added <p>Updated the maximum value of DC16 as 2.1 in Table 31-4</p> <p>Updated the Typical values for the following parameters: DC20b, DC20c, DC21c, DC22c and DC23c (see Table 31-5)</p> <p>Updated Table 31-11:</p> <ul style="list-style-type: none"> • Removed the following DC Characteristics: Programming temperature 0°C ≤TA ≤+70°C (25°C recommended) • Updated the Minimum value for the Parameter number D131 as 2.3 • Removed the Conditions for the following Parameter numbers: D130, D131, D132, D135, D136 and D137 • Updated the condition for the parameter number D130a and D132a <p>Updated the Minimum, Typical and Maximum values for parameter D305 in Table 31-13</p> <p>Added note 2 to Table 31-18</p> <p>Updated the Minimum and Maximum values for parameter F20b (see Table 31-19)</p> <p>Updated the following figures:</p> <ul style="list-style-type: none"> • Figure 31-4 • Figure 31-9 • Figure 31-19 • Figure 31-20
<p>Appendix A: “Migrating from PIC32MX3XX/4XX to PIC32MX5XX/6XX/7XX Devices”</p>	<p>Removed the A.3 Pin Assignments sub-section.</p>

Revision G (May 2011)

The revision includes the following global update:

- All references to VDDCORE/VCAP have been changed to: VCORE/VCAP
- Added references to the new V-Temp temperature range: -40°C to +105°C

This revision also includes minor typographical and formatting changes throughout the data sheet text. Major updates are referenced by their respective section in the following table.

TABLE B-5: MAJOR SECTION UPDATES

Section Name	Update Description
High-Performance, USB, CAN and Ethernet 32-bit Flash Microcontrollers	Removed the shading for all D- and D+ pins in all pin diagrams.
1.0 “Device Overview”	Updated the VBUS description in Table 1-1 .
2.0 “Guidelines for Getting Started with 32-bit Microcontrollers”	Added 2.11 “Referenced Sources” .
4.0 “Memory Organization”	Added Note 3 to the Interrupt Register Map tables (see Table 4-2 through Table 4-7).
22.0 “10-bit Analog-to-Digital Converter (ADC)”	Updated the ADC Conversion Clock Period Block Diagram (see Figure 22-2).
26.0 “Comparator Voltage Reference (CVREF)”	Updated the Comparator Voltage Reference Block Diagram (see Figure 26-1).
28.0 “Special Features”	Removed the second paragraph from 28.3.1 “On-Chip Regulator and POR” .
31.0 “Electrical Characteristics”	<p>Added the new V-Temp temperature range (-40°C to +105°C) to the heading of all specification tables.</p> <p>Updated the Ambient temperature under bias, updated the Voltage on any 5V tolerant pin with respect to Vss when VDD < 2.3V, and added Voltage on VBUS with respect to Vss in Absolute Maximum Ratings.</p> <p>Added the characteristic, DC5a to Operating MIPS vs. Voltage (see Table 31-1).</p> <p>Updated or added the following parameters to the Operating Current (IDD) DC Characteristics: DC20, DC20b, DC23, and DC23b (see Table 31-5).</p> <p>Added the following parameters to the Idle Current (IDLE) DC Characteristics: DC30b, DC33b, DC34c, DC35c, and DC36c (see Table 31-6).</p> <p>Added the following parameters to the Power-down Current (IPD) DC Characteristics: DC40g, DC40h, DC40i, and DC41g, (see Table 31-7).</p> <p>Added parameter IM51 and Note 3 to the I2Cx Bus Data Timing Requirements (Master Mode) (see Table 31-32).</p> <p>Updated the 10-bit ADC Conversion Rate Parameters (see Table 31-37).</p> <p>Updated parameter AD57 (TSAMP) in the Analog-to-Digital Conversion Timing Requirements (see Table 31-38).</p>
32.0 “Packaging Information”	Updated the 64-Lead Plastic Quad Flat, No Lead Package (MR) – 9x9x0.9 mm Body [QFN] packing diagram.
Product Identification System	Added the new V-Temp (V) temperature information.

NOTES:

INDEX

A

AC Characteristics	194
10-bit Conversion Rate Parameters	216
ADC Specifications	214
Analog-to-Digital Conversion Requirements	217
EJTAG Timing Requirements	224
Ethernet	213
Internal FRC Accuracy	196
Internal RC Accuracy	197
OTG Electrical Specifications	223
Parallel Master Port Read Requirements	221
Parallel Master Port Write	222
Parallel Master Port Write Requirements	222
Parallel Slave Port Requirements	220
PLL Clock Timing	196
Analog-to-Digital Converter (ADC)	153
Assembler	
MPASM Assembler	180

B

Block Diagrams	
ADC Module	153
Comparator I/O Operating Modes	159
Comparator Voltage Reference	161
Connections for On-Chip Voltage Regulator	174
Core and Peripheral Modules	31
DMA	129
Ethernet Controller	157
I2C Circuit	146
Input Capture	139
Interrupt Controller	121
JTAG Programming, Debugging and Trace Ports	175
MCU	49
Output Compare Module	141
PIC32 CAN Module	155
PMP Pinout and Connections to External Devices	149
Prefetch Module	127
Reset System	119
RTCC	151
SPI Module	143
Timer1	135
Timer2/3/4/5 (16-Bit)	137
Typical Multiplexed Port Structure	133
UART	147
WDT and Power-up Timer	173
Brown-out Reset (BOR)	
and On-Chip Voltage Regulator	174

C

C Compilers	
MPLAB C18	180
Clock Diagram	125
Comparator	
Specifications	192
Comparator Module	159
Comparator Voltage Reference (CVref)	161
Configuration Bit	165
Controller Area Network (CAN)	155
CPU Module	43
Customer Change Notification Service	253
Customer Notification Service	253
Customer Support	253

D

DC Characteristics	184
I/O Pin Input Specifications	189
I/O Pin Output Specifications	190
Idle Current (I _{IDLE})	186
Operating Current (I _{DD})	185
Power-Down Current (I _{PD})	187
Program Memory	191
Temperature and Voltage Specifications	184
Development Support	179
Direct Memory Access (DMA) Controller	129

E

Electrical Characteristics	183
AC	194
Errata	29
Ethernet Controller	157
External Clock	
Timer1 Timing Requirements	200
Timer2, 3, 4, 5 Timing Requirements	201
Timing Requirements	195

F

Flash Program Memory	117
RTSP Operation	117

I

I/O Ports	133
Parallel I/O (PIO)	134
Instruction Set	177
Inter-Integrated Circuit (I2C)	145
Internal Voltage Reference Specifications	193
Internet Address	253
Interrupt Controller	121
IRG, Vector and Bit Location	122

M

MCU	
Architecture Overview	50
Coprocessor 0 Registers	52
Core Exception Types	53
EJTAG Debug Support	54
Power Management	54
MCU Module	49
Memory Map	60
Memory Maps	56, 57, 58, 59, 61
Memory Organization	55
Layout	55
Microchip Internet Web Site	253
Migration	
PIC32MX3XX/4XX to PIC32MX5XX/6XX/7XX	239
MPLAB ASM30 Assembler, Linker, Librarian	180
MPLAB Integrated Development Environment Software	179
MPLAB PM3 Device Programmer	182
MPLAB REAL ICE In-Circuit Emulator System	181
MPLINK Object Linker/MPLIB Object Librarian	180

O

Open-Drain Configuration	134
Oscillator Configuration	125
Output Compare	141

P

Packaging	225
-----------------	-----

PIC32MX5XX/6XX/7XX

Details	227	I/O Characteristics	197
Marking	225	I2Cx Bus Data (Master Mode)	208
Parallel Master Port (PMP)	149	I2Cx Bus Data (Slave Mode)	210
PIC32 Family USB Interface Diagram	132	I2Cx Bus Start/Stop Bits (Master Mode)	208
Pinout I/O Descriptions (table)	32	I2Cx Bus Start/Stop Bits (Slave Mode)	210
Power-on Reset (POR)		Input Capture (CAPx)	201
and On-Chip Voltage Regulator	174	OCx/PWM	202
Power-Saving Features	163	Output Compare (OCx)	202
CPU Halted Methods	163	Parallel Master Port Read	221
Operation	163	Parallel Master Port Write	222
with CPU Running	163	Parallel Slave Port	220
Prefetch Cache	127	SPIx Master Mode (CKE = 0)	203
Program Flash Memory		SPIx Master Mode (CKE = 1)	204
Wait State Characteristics	192	SPIx Slave Mode (CKE = 0)	205
R		SPIx Slave Mode (CKE = 1)	206
Reader Response	254	Timer1, 2, 3, 4, 5 External Clock	200
Real-Time Clock and Calendar (RTCC)	151	UART Reception	148
Register Maps	62–116	UART Transmission (8-bit or 9-bit Data)	148
Registers		Timing Requirements	
DDPCON (Debug Data Port Control)	176	CLKO and I/O	197
DEVCFG0 (Device Configuration Word 0)	166	Timing Specifications	
DEVCFG1 (Device Configuration Word 1)	168	CAN I/O Requirements	212
DEVCFG2 (Device Configuration Word 2)	170	I2Cx Bus Data Requirements (Master Mode)	209
DEVCFG3 (Device Configuration Word 3)	171	I2Cx Bus Data Requirements (Slave Mode)	211
DEVID (Device and Revision ID)	172	Input Capture Requirements	201
Resets	119	Output Compare Requirements	202
Revision History	240	Simple OCx/PWM Mode Requirements	202
S		SPIx Master Mode (CKE = 0) Requirements	203
Serial Peripheral Interface (SPI)	143	SPIx Master Mode (CKE = 1) Requirements	204
Software Simulator (MPLAB SIM)	181	SPIx Slave Mode (CKE = 1) Requirements	206
Special Features	165	SPIx Slave Mode Requirements (CKE = 0)	205
T		U	
Timer1 Module	135	UART	147
Timer2/3, Timer4/5 Modules	137	USB On-The-Go (OTG)	131
Timing Diagrams		V	
10-bit Analog-to-Digital Conversion (ASAM = 0, SS- RC<2:0> = 000)	218	VCAP/VCORE pin	174
10-bit Analog-to-Digital Conversion (CHPS<1:0> = 01, ASAM = 1, SSRC<2:0> = 111, SAMC<4:0> = 00001)	219	Voltage Reference Specifications	193
CAN I/O	212	Voltage Regulator (On-Chip)	174
EJTAG	224	W	
External Clock	194	Watchdog Timer (WDT)	173
		WWW Address	253
		WWW, On-Line Support	29

THE MICROCHIP WEB SITE

Microchip provides online support via our WWW site at www.microchip.com. This web site is used as a means to make files and information easily available to customers. Accessible by using your favorite Internet browser, the web site contains the following information:

- **Product Support** – Data sheets and errata, application notes and sample programs, design resources, user's guides and hardware support documents, latest software releases and archived software
- **General Technical Support** – Frequently Asked Questions (FAQ), technical support requests, online discussion groups, Microchip consultant program member listing
- **Business of Microchip** – Product selector and ordering guides, latest Microchip press releases, listing of seminars and events, listings of Microchip sales offices, distributors and factory representatives

CUSTOMER CHANGE NOTIFICATION SERVICE

Microchip's customer notification service helps keep customers current on Microchip products. Subscribers will receive e-mail notification whenever there are changes, updates, revisions or errata related to a specified product family or development tool of interest.

To register, access the Microchip web site at www.microchip.com. Under "Support", click on "Customer Change Notification" and follow the registration instructions.

CUSTOMER SUPPORT

Users of Microchip products can receive assistance through several channels:

- Distributor or Representative
- Local Sales Office
- Field Application Engineer (FAE)
- Technical Support
- Development Systems Information Line

Customers should contact their distributor, representative or field application engineer (FAE) for support. Local sales offices are also available to help customers. A listing of sales offices and locations is included in the back of this document.

Technical support is available through the web site at: <http://microchip.com/support>

PIC32MX5XX/6XX/7XX

READER RESPONSE

It is our intention to provide you with the best documentation possible to ensure successful use of your Microchip product. If you wish to provide your comments on organization, clarity, subject matter, and ways in which our documentation can better serve you, please FAX your comments to the Technical Publications Manager at (480) 792-4150.

Please list the following information, and use this outline to provide us with your comments about this document.

TO: Technical Publications Manager
RE: Reader Response

Total Pages Sent _____

From: Name _____

Company _____

Address _____

City / State / ZIP / Country _____

Telephone: (_____) _____ - _____

FAX: (_____) _____ - _____

Application (optional):

Would you like a reply? ___ Y ___ N

Device: PIC32MX5XX/6XX/7XX

Literature Number: DS61156G

Questions:

1. What are the best features of this document?

2. How does this document meet your hardware and software development needs?

3. Do you find the organization of this document easy to follow? If not, why?

4. What additions to the document do you think would enhance the structure and subject?

5. What deletions from the document could be made without affecting the overall usefulness?

6. Is there any incorrect or misleading information (what and where)?

7. How would you improve this document?

PRODUCT IDENTIFICATION SYSTEM

To order or obtain information, e.g., on pricing or delivery, refer to the factory or the listed sales office.

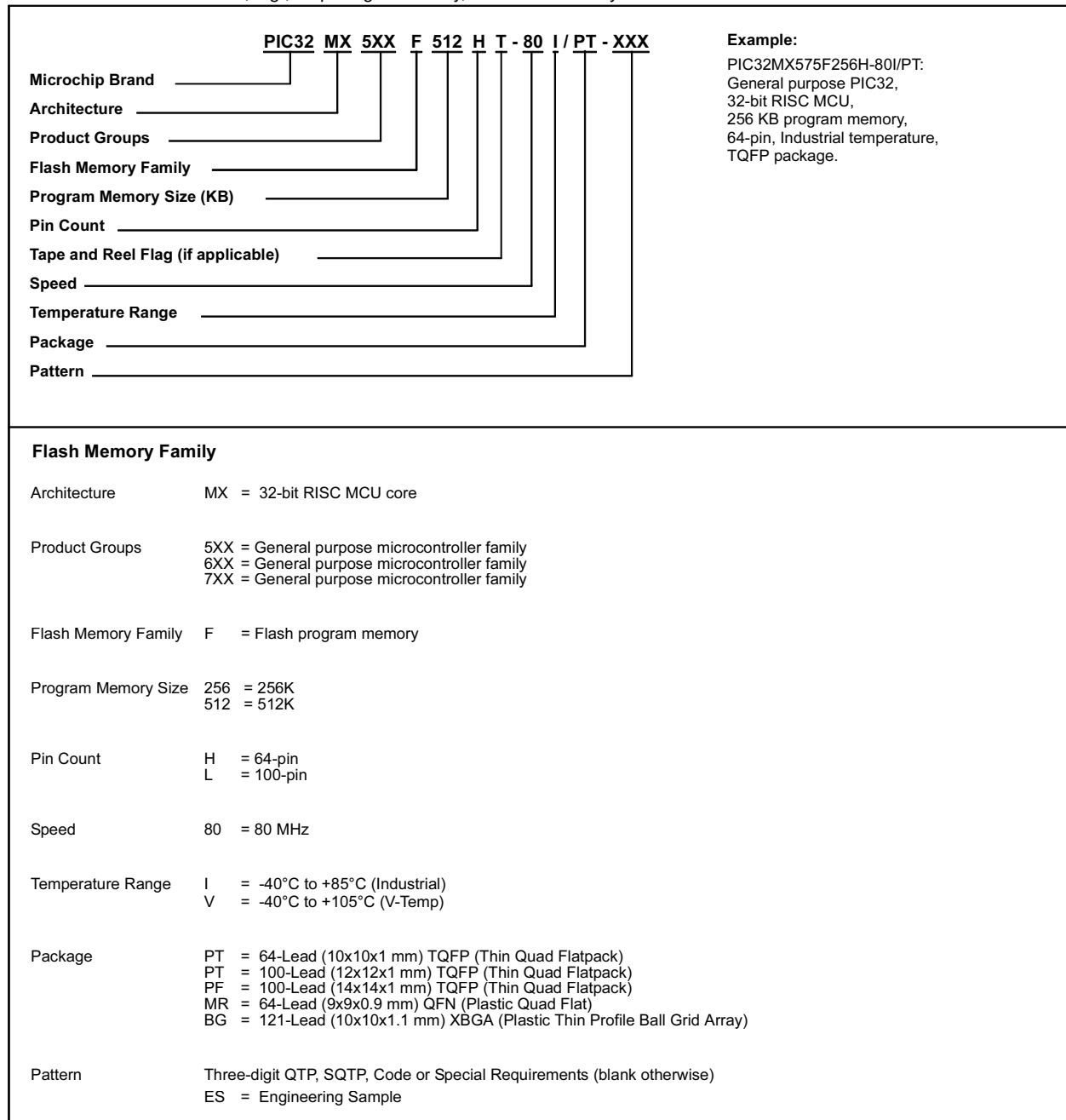



MICROCHIP

Worldwide Sales and Service

AMERICAS

Corporate Office

2355 West Chandler Blvd.
Chandler, AZ 85224-6199
Tel: 480-792-7200
Fax: 480-792-7277
Technical Support:
<http://www.microchip.com/support>

Web Address:
www.microchip.com

Atlanta

Duluth, GA
Tel: 678-957-9614
Fax: 678-957-1455

Boston

Westborough, MA
Tel: 774-760-0087
Fax: 774-760-0088

Chicago

Itasca, IL
Tel: 630-285-0071
Fax: 630-285-0075

Cleveland

Independence, OH
Tel: 216-447-0464
Fax: 216-447-0643

Dallas

Addison, TX
Tel: 972-818-7423
Fax: 972-818-2924

Detroit

Farmington Hills, MI
Tel: 248-538-2250
Fax: 248-538-2260

Indianapolis

Noblesville, IN
Tel: 317-773-8323
Fax: 317-773-5453

Los Angeles

Mission Viejo, CA
Tel: 949-462-9523
Fax: 949-462-9608

Santa Clara

Santa Clara, CA
Tel: 408-961-6444
Fax: 408-961-6445

Toronto

Mississauga, Ontario,
Canada
Tel: 905-673-0699
Fax: 905-673-6509

ASIA/PACIFIC

Asia Pacific Office

Suites 3707-14, 37th Floor
Tower 6, The Gateway
Harbour City, Kowloon
Hong Kong
Tel: 852-2401-1200
Fax: 852-2401-3431

Australia - Sydney

Tel: 61-2-9868-6733
Fax: 61-2-9868-6755

China - Beijing

Tel: 86-10-8569-7000
Fax: 86-10-8528-2104

China - Chengdu

Tel: 86-28-8665-5511
Fax: 86-28-8665-7889

China - Chongqing

Tel: 86-23-8980-9588
Fax: 86-23-8980-9500

China - Hangzhou

Tel: 86-571-2819-3180
Fax: 86-571-2819-3189

China - Hong Kong SAR

Tel: 852-2401-1200
Fax: 852-2401-3431

China - Nanjing

Tel: 86-25-8473-2460
Fax: 86-25-8473-2470

China - Qingdao

Tel: 86-532-8502-7355
Fax: 86-532-8502-7205

China - Shanghai

Tel: 86-21-5407-5533
Fax: 86-21-5407-5066

China - Shenyang

Tel: 86-24-2334-2829
Fax: 86-24-2334-2393

China - Shenzhen

Tel: 86-755-8203-2660
Fax: 86-755-8203-1760

China - Wuhan

Tel: 86-27-5980-5300
Fax: 86-27-5980-5118

China - Xian

Tel: 86-29-8833-7252
Fax: 86-29-8833-7256

China - Xiamen

Tel: 86-592-2388138
Fax: 86-592-2388130

China - Zhuhai

Tel: 86-756-3210040
Fax: 86-756-3210049

ASIA/PACIFIC

India - Bangalore

Tel: 91-80-3090-4444
Fax: 91-80-3090-4123

India - New Delhi

Tel: 91-11-4160-8631
Fax: 91-11-4160-8632

India - Pune

Tel: 91-20-2566-1512
Fax: 91-20-2566-1513

Japan - Yokohama

Tel: 81-45-471- 6166
Fax: 81-45-471-6122

Korea - Daegu

Tel: 82-53-744-4301
Fax: 82-53-744-4302

Korea - Seoul

Tel: 82-2-554-7200
Fax: 82-2-558-5932 or
82-2-558-5934

Malaysia - Kuala Lumpur

Tel: 60-3-6201-9857
Fax: 60-3-6201-9859

Malaysia - Penang

Tel: 60-4-227-8870
Fax: 60-4-227-4068

Philippines - Manila

Tel: 63-2-634-9065
Fax: 63-2-634-9069

Singapore

Tel: 65-6334-8870
Fax: 65-6334-8850

Taiwan - Hsin Chu

Tel: 886-3-6578-300
Fax: 886-3-6578-370

Taiwan - Kaohsiung

Tel: 886-7-213-7830
Fax: 886-7-330-9305

Taiwan - Taipei

Tel: 886-2-2500-6610
Fax: 886-2-2508-0102

Thailand - Bangkok

Tel: 66-2-694-1351
Fax: 66-2-694-1350

EUROPE

Austria - Wels

Tel: 43-7242-2244-39
Fax: 43-7242-2244-393

Denmark - Copenhagen

Tel: 45-4450-2828
Fax: 45-4485-2829

France - Paris

Tel: 33-1-69-53-63-20
Fax: 33-1-69-30-90-79

Germany - Munich

Tel: 49-89-627-144-0
Fax: 49-89-627-144-44

Italy - Milan

Tel: 39-0331-742611
Fax: 39-0331-466781

Netherlands - Drunen

Tel: 31-416-690399
Fax: 31-416-690340

Spain - Madrid

Tel: 34-91-708-08-90
Fax: 34-91-708-08-91

UK - Wokingham

Tel: 44-118-921-5869
Fax: 44-118-921-5820

05/02/11