

Date: 10 Mar 2011

Product Category:

Device Family:  

Notification subject: Data Sheet - MCP2200 Data Sheet

Notification text: SYST-10LHXZ967
Microchip has released a new DeviceDoc for the MCP2200 Data Sheet of devices. If you are using one of these devices please read the document located at [MCP2200 Data Sheet](#).

Attachment(s): [MCP2200 Data Sheet](#)

Please contact your local [Microchip sales office](#) with questions or concerns regarding this notification.

Terms and Conditions:

If you wish to change your product/process change notification (PCN) profile please log on to our website at <http://www.microchip.com/PCN> sign into myMICROCHIP to open the myMICROCHIP home page, then select a profile option from the left navigation bar.

To opt out of future offer or information emails (other than product change notification emails), click here to go to [microchipDIRECT](#) and login, then click on the "My account" link, click on "Update profile" and un-check the box that states "Future offers or information about Microchip's products or services."

Parts Affected

MCP2200

USB 2.0 to UART Protocol Converter with GPIO

Features

Universal Serial Bus (USB)

- Supports full-speed USB (12 Mb/s)
- Implements USB protocol composite device:
 - Communication Device Class (CDC) for communications and configuration
 - Human Interface Device (HID) for I/O control
- 128-byte buffer to handle data throughput at any UART baud rate:
 - 64-byte transmit
 - 64-byte receive
- Fully configurable VID and PID assignments, and string descriptors
- Bus powered or self-powered
- USB 2.0 Compliant: TID 40001150

USB Driver and Software Support

- Uses standard Windows® drivers for Virtual Com Port (VCP): Windows XP (SP2 or later), Vista, 7
- Configuration utility for initial configuration

Universal Asynchronous Receiver/Transmitter (UART)

- Responds to SET LINE CODING commands to dynamically change baud rates
- Supports baud rates: 300-1000k
- Hardware flow control
- UART signal polarity option

General Purpose Input/Output (GPIO) Pins

- Eight general purpose I/O pins

EEPROM

- 256 bytes of user EEPROM

Other

- USB activity LED outputs (TxLED and RxLED)
- SSPND output pin
- USBCFG output pin (indicates when the enumeration is completed)
- Operating voltage: 3.0-5.5V
- Oscillator input: 12 MHz
- ESD protection: > 4 kV HBM
- Industrial (I) Operating Temperature: -40°C to +85°C

Package Types

The device will be offered in the following packages:

- 20-lead QFN (5 x 5 mm)
- 20-lead SOIC
- 20-lead SSOP

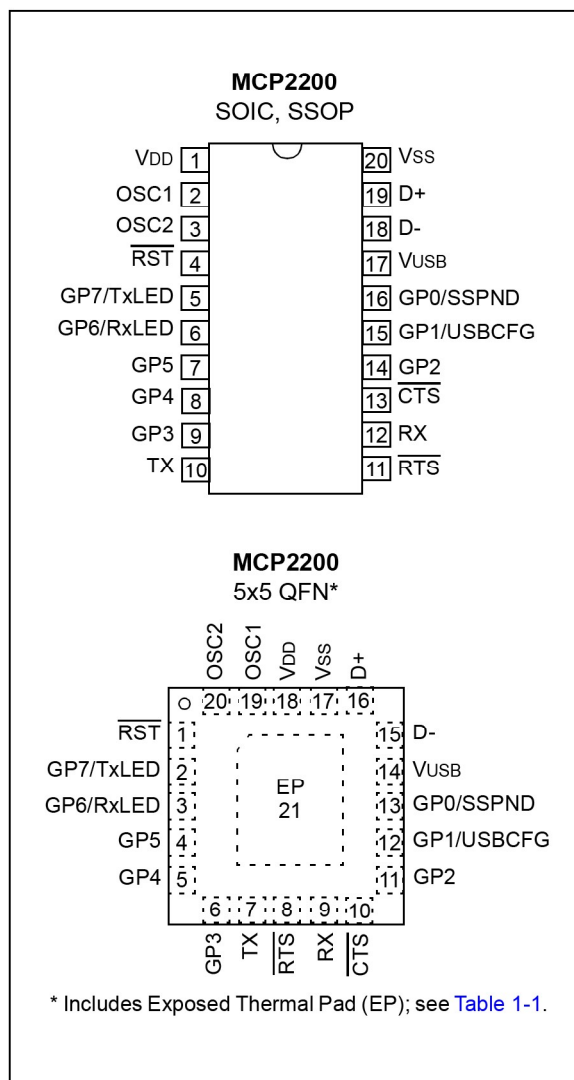

MCP2200

Block Diagram

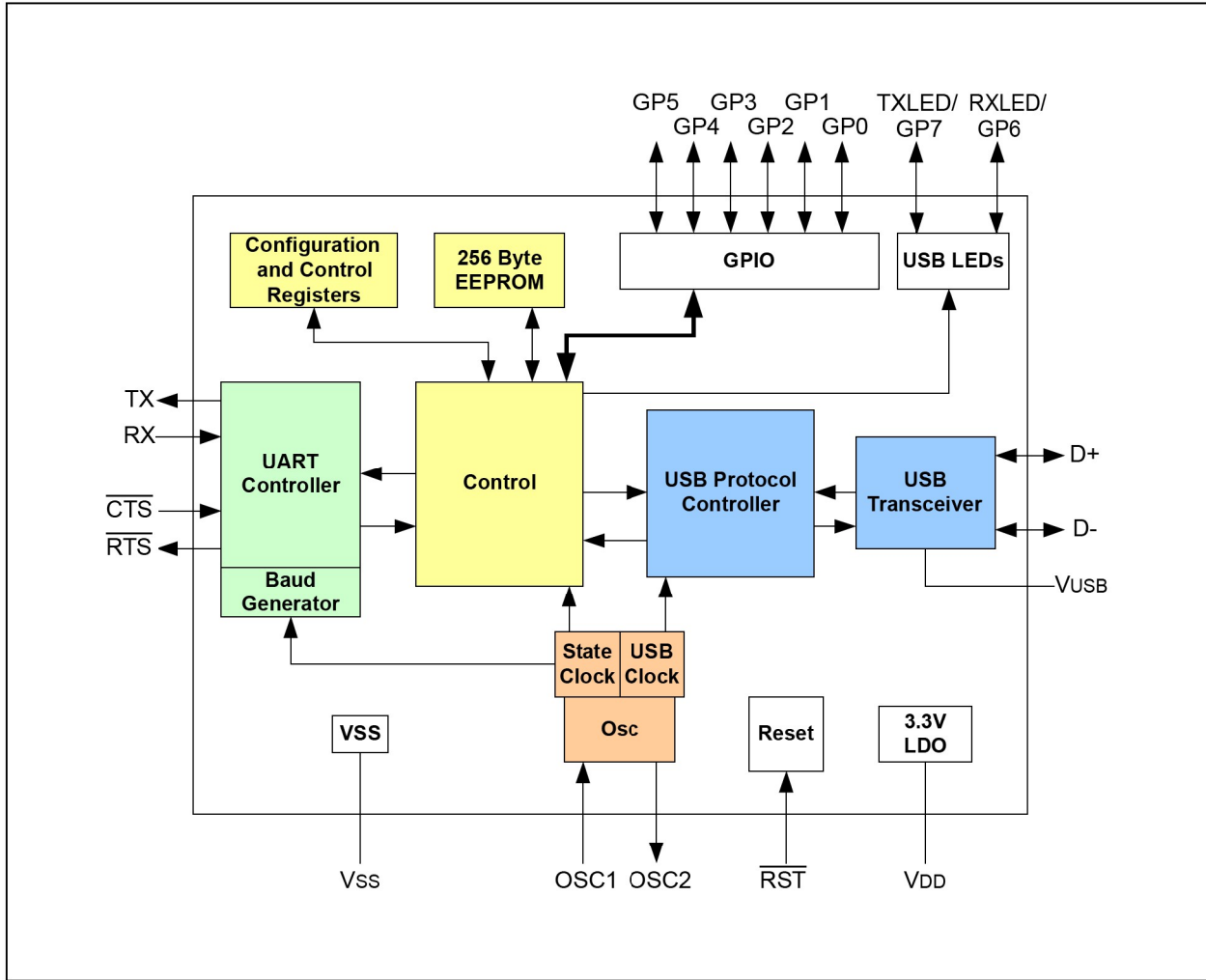

1.0 FUNCTIONAL DESCRIPTION

The MCP2200 is a USB-to-UART serial converter which enables USB connectivity in applications that have a UART interface. The device reduces external components by integrating the USB termination resistors. The MCP2200 also has 256 bytes of integrated user EEPROM.

The MCP2200 has eight general purpose input/output pins. Four pins have alternate functions to indicate USB and communication status. See [Table 1-1](#) and [Section 1.6 “GPIO Module”](#) for details about the pin functions.

TABLE 1-1: PINOUT DESCRIPTION

Pin Name	SSOP, SOIC	QFN	Pin Type	Standard Function	Alternate Function
GP0/SSPND	16	13	I/O	General purpose I/O	USB suspend status pin (refer to Section 1.6.1.1)
GP1/USB-CFG	15	12	I/O	General purpose I/O	USB configuration status pin (refer to Section 1.6.1.2)
GP2	14	11	I/O	General purpose I/O	
GP3	9	6	I/O	General purpose I/O	
GP4	8	5	I/O	General purpose I/O	
GP5	7	4	I/O	General purpose I/O	
GP6/RxLED	6	3	I/O	General purpose I/O	USB receive activity LED output (refer to Section 1.6.1.3)
GP7/TxLED	5	2	I/O	General purpose I/O	USB transmit activity LED output (refer to Section 1.6.1.4)
$\overline{\text{RST}}$	4	1	I	Reset input must be externally biased	
$\overline{\text{CTS}}$	13	10	I	Hardware flow control “Clear to Send” input signal	
RX	12	9	I	USART RX input	
$\overline{\text{RTS}}$	11	8	O	Hardware flow control “Request to Send” output signal	
TX	10	7	O	USART TX output	
VDD	1	18	P	Power	
VSS	20	17	P	Ground	
OSC1	2	19	I	Oscillator input	
OSC2	3	20	O	Oscillator output	
D+	19	16	I/O	USB D+	
D-	18	15	I/O	USB D-	
VUSB	17	14	P	USB power pin (internally connected to 3.3V). Should be locally bypassed with a high quality ceramic capacitor.	
EP	—	21	—	Exposed Thermal Pad (EP). Do not electrically connect.	

MCP2200

1.1 Supported Operating Systems

Windows XP (SP2 and later), Vista, and Windows 7 operating systems are supported.

1.1.1 ENUMERATION

The MCP2200 will enumerate as a USB device after Power-on Reset (POR). The device enumerates as both a Human Interface Device (HID) for I/O control, and a VCP.

1.1.1.1 HID

The MCP2200 enumerates as an HID, so the device can be configured and the I/O can be controlled. A DLL that facilitates I/O control through a custom interface is supplied by Microchip.

1.1.1.2 VCP

The VCP enumeration implements the USB-to-UART data translation.

1.2 Control Module

The control module is the heart of the MCP2200. All other modules are tied together and controlled via the control module. The control module manages the data transfers between the USB and the UART, as well as command requests generated by the USB host controller, and commands for controlling the function of the UART and I/O.

1.2.1 SERIAL INTERFACE

The control module interfaces to the UART and USB modules.

1.2.2 INTERFACING TO THE DEVICE

The MCP2200 can be accessed for reading and writing via USB host commands. The device cannot be accessed and controlled via the UART interface.

1.3 UART Interface

The MCP2200 UART interface consists of the TX and RX data signals and the RTS/CTS flow control pins.

The UART is configurable for several baud rates. The available baud rates are listed in [Table 1-3](#).

1.3.1 INITIAL CONFIGURATION

The default UART configuration is 19200, 8, N, 1. The default start up baud rate can be changed using the Microchip-supplied configuration PC tool.

Alternatively, a custom configuration tool can be created using the Microchip-supplied DLL to set the baud rate, as well as other parameters. See [Section 2.0 “Configuration”](#) for details.

TABLE 1-2: UART CONFIGURATIONS

Parameter	Configuration
Primary Baud Rates	See Table 1-3
Data Bits	8
Parity	N
Stop Bits	1

1.3.2 GET/SET LINE CODING

The `GET_LINE_CODING` and `SET_LINE_CODING` commands are used to read and set the UART parameters while in operation. For example, Hyperterminal sends the `SET_LINE_COMMAND` when connecting to the port. The MCP2200 responds by setting the baud rate only. The other parameters (Data Bits, Parity, Stop Bits) remain unchanged.

1.3.2.1 Rounding Errors

The primary baud rate setting (with the rounding errors) is shown in [Table 1-3](#). If baud rates other than the ones shown in the table are used, the error percentage can be calculated using [Equation 1-1](#) to find the actual baud rate.

TABLE 1-3: UART PRIMARY BAUD RATES

Desired Rate	Actual rate	% Error
300	300	0.00%
1200	1200	0.00%
2400	2400	0.00%
4800	4800	0.00%
9600	9600	0.00%
19200	19200	0.00%
38400	38339	0.16%
57600	57692	0.16%
115200	115385	0.16%
230400	230769	0.16%
460800	461538	0.16%
921600	923077	0.16%

EQUATION 1-1: SOLVING FOR ACTUAL BAUD RATE

$$ActualRate = \frac{12MHz}{int(x)}$$

Where:

$$x = \frac{12MHz}{DesiredBaud}$$

1.3.3 CUSTOM BAUD RATES

Custom baud rates are configured by sending the `SET_LINE_CODING` USB command, or by using the DLL. See [Section 2.0 “Configuration”](#) for more information.

1.3.4 HARDWARE FLOW CONTROL

Hardware flow control uses the `RTS` and `CTS` pins as a handshake between two devices. The `RTS` pin of one device is typically connected to the `CTS` of the other device.

`RTS` is an active low output that notifies the other device when it is ready to receive data by driving the pin low. The MCP2200 trip point for de-asserting `RTS` (high) is 63 characters. This is one character short of “buffer full”.

`CTS` is an active low input that notifies the MCP2200 when it is ready to send data. The MCP2200 will check `CTS` just before loading and sending UART data. If the pin is asserted during a transfer, the transfer will continue. Refer to [Figure 1.4](#).

FIGURE 1-1: `RTS/CTS` CONNECTIONS EXAMPLE

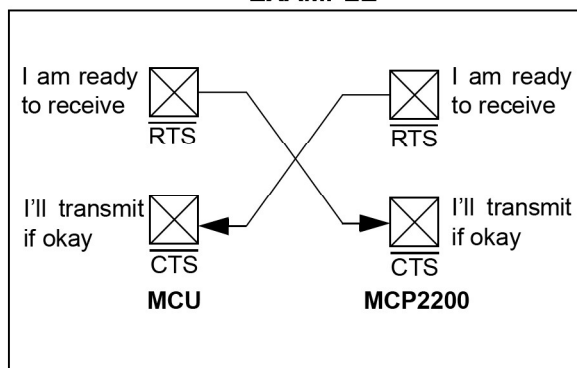

1.3.4.1 Flow Control Disabled

The buffer pointer does not increment (or reset to zero) if the buffer is full. Therefore, if hardware flow control is not enabled and an overflow occurs (i.e., 65 unprocessed characters received), the new data overwrites the last position in the buffer.

1.4 USB Protocol Controller

The USB controller in the MCP2200 is full-speed USB 2.0 compliant.

- Composite device (CDC + HID):
 - CDC: USB-to-UART communications
 - HID: I/O control, EEPROM access and initial configuration
- 128 byte buffer to handle data throughput at any UART baud rate:
 - 64-byte transmit
 - 64-byte receive
- Fully configurable VID and PID assignments, and descriptors (stored on-chip)
- Bus powered or self-powered

1.4.1 DESCRIPTORS

During configuration, the supplied PC interface stores the descriptors in the MCP2200.

1.4.2 SUSPEND AND RESUME

The USB Suspend and Resume signals are supported for power management of the MCP2200. The device enters Suspend mode when “suspend signaling” is detected on the bus.

The MCP2200 exits Suspend mode when any of the following events occur:

1. “Resume signaling” is detected or generated
2. A USB “Reset” signal is detected
3. A device Reset occurs

1.5 USB Transceiver

The MCP2200 has a built-in, USB 2.0, full-speed transceiver internally connected to the USB module.

The USB transceiver obtains power from the `VUSB` pin, which is internally connected to the 3.3V regulator. The best electrical signal quality is obtained when `VUSB` is locally bypassed with a high quality ceramic capacitor.

1.5.1 INTERNAL PULL-UP RESISTORS

The MCP2200 devices have built-in pull-up resistors designed to meet the requirements for full-speed USB.

1.5.2 MCP2200 POWER OPTIONS

The following are the main power options for the MCP2200:

- USB Bus Powered (5V)
- 3.3V Self Powered

MCP2200

1.5.2.1 Internal Power Supply Details

MCP2200 offers various options for power supply. To meet the required USB signaling levels, MCP2200 device incorporates an internal LDO used solely by the USB transceiver, in order to present the correct D+/D- voltage levels.

Figure 1-2 shows the internal connections of the USB transceiver LDO in relation with the VDD power supply rail. The output of the USB transceiver LDO is tied to the VUSB line. A capacitor connected to the VUSB pin is required if the USB transceiver LDO provides the 3.3V supply to the transceiver.

FIGURE 1-2: MCP2200 INTERNAL POWER SUPPLY DETAILS

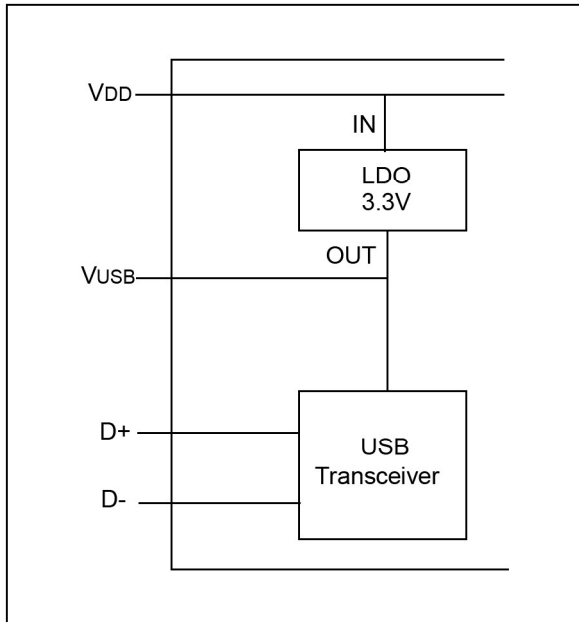

The provided VDD voltage has a direct influence on the voltage levels present on the GPIO pins (Rx/Tx and RTS/CTS). When VDD is 5V, all of these pins will have a logical '1' around 5V with the variations specified in Section 3.1, DC Characteristics.

For applications that require a 3.3V logical '1' level, VDD must be connected to a power supply providing the 3.3V voltage. In this case, the internal USB transceiver LDO cannot provide the required 3.3V power. It is necessary to also connect the VUSB pin of the MCP2200 to the 3.3V power supply rail. This way, the USB transceiver is powered up directly from the 3.3V power supply.

1.5.2.2 USB Bus Powered (5V)

In Bus Power Only mode, all power for the application is drawn from the USB (Figure 1-3). This is effectively the simplest power method for the device.

FIGURE 1-3: BUS POWER ONLY

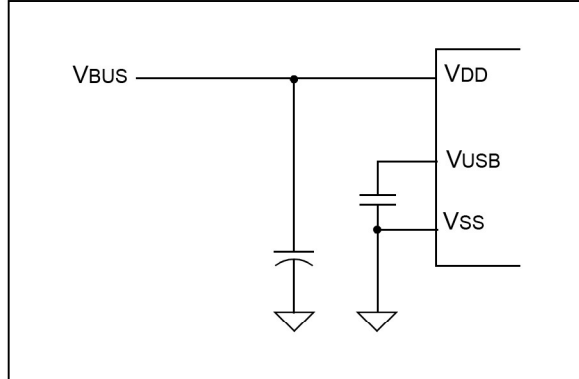

In order to meet the inrush current requirements of the USB 2.0 specifications, the total effective capacitance appearing across VBUS and ground must be no more than 10 μF . If it is not more than 10 μF , some kind of inrush limiting is required. For more details on Inrush Current Limiting, search for that subject in the current *Universal Serial Bus Specification*.

According to the USB 2.0 specification, all USB devices must also support a Low-Power Suspend mode. In the USB Suspend mode, devices must consume no more than 500 μA (or 2.5 mA for high powered devices that are remote wake-up capable) from the 5V VBUS line of the USB cable.

The host signals the USB device to enter Suspend mode by stopping all USB traffic to that device for more than 3 ms.

The USB bus provides a 5V voltage. However, the USB transceiver requires 3.3V for the signaling (on D+ and D- lines).

During USB Suspend mode, the D+ or D- pull-up resistor must remain active, which will consume some of the allowed suspend current budget (500 μA /2.5 mA). The VUSB pin is required to have an external bypass capacitor. It is recommended that the capacitor be a ceramic cap, between 0.22 and 0.47 μF .

Figure 1-4 shows a circuit where MCP2200's internal LDO is used to provide 3.3V to the USB transceiver. The voltage on the VDD affects the voltage levels onto the GPIO pins (Rx/Tx and RTS/CTS). With VDD at 5V, these pins will have a logic '1' of 5V with the variations specified in Section 3.1, DC Characteristics.

FIGURE 1-4: TYPICAL POWER SUPPLY OPTION USING THE 5V PROVIDED BY THE USB

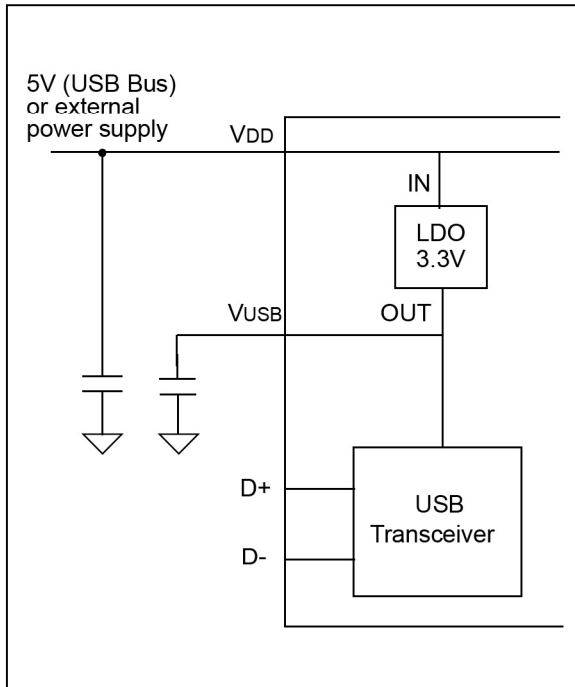

1.5.2.3 3.3V Self Powered

Typically, many embedded applications are using 3.3V power supplies. When such an option is available in the target system, MCP2200 can be powered up from the existing 3.3V power supply rail. The typical connections for MCP2200 are shown in [Figure 1-5](#).

In this example MCP2200 has both VDD and VUSB lines tied to the 3.3V rail. These tied connections disable the internal USB transceiver LDO of the MCP2200 to regulate the power supply on VUSB pin. Another consequence is that the '1' logical level on the GPIO pins will be at the 3.3V level, in accordance with the variations specified in [Section 3.1, DC Characteristics](#).

FIGURE 1-5: USING AN EXTERNALLY PROVIDED 3.3V POWER SUPPLY

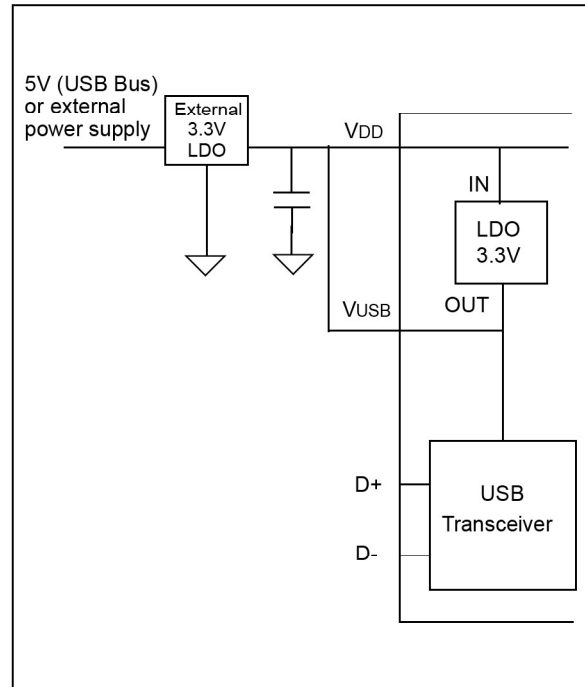

1.6 GPIO Module

The GPIO Module is a standard 8-bit I/O port.

1.6.1 CONFIGURABLE PIN FUNCTIONS

The pins can be configured as:

- GPIO – individually configurable general purpose input or output
- SSPND – USB Suspend state
- USBCFG – indicates USB configuration status
- RxLED – indicates USB receive traffic
- TxLED – indicates USB transmit traffic

1.6.1.1 SSPND Pin Function

The SSPND pin (if enabled) reflects the USB state (Suspend/Resume). The pin is active 'low' when the Suspend state has been issued by the USB host. Likewise, the pin drives 'high' after the Resume state is achieved.

This pin allows the application to go into Low Power mode when USB communication is suspended, and switches to a full active state when USB activity is resumed.

1.6.1.2 USBCFG Pin Function

The USBCFG pin (if enabled) starts out 'low' during power-up or after Reset, and goes 'high' after the device successfully configures to the USB. The pin will go 'low' when in Suspend mode and 'high' when the USB resumes.

MCP2200

1.6.1.3 RxLED Pin Function (IN Message)

The 'Rx' in the pin name is in respect to the USB host. The RxLED pin is an indicator for USB 'IN' messages.

This pin will either pulse low for a period of time (configurable for ~100 ms or ~200 ms), or toggle to the opposite state for every message received (IN message) by the USB host. This allows the application to count messages or provide a visual indication of USB traffic.

1.6.1.4 TxLED Pin Function (OUT Message)

The 'Tx' in the pin name is in respect to the USB host. The TxLED pin is an indicator for USB 'OUT' messages.

This pin will either pulse low for a period of time (configurable for ~100 ms or ~200 ms), or toggle to the opposite state for every message transmitted (OUT message) by the USB host. This allows the application to count messages or provide a visual indication of USB traffic.

1.7 EEPROM Module

The EEPROM module is a 256 byte array of nonvolatile memory. The memory locations are accessed for read/write operations via USB host commands. Refer to [Section 2.0 "Configuration"](#) for details on accessing the EEPROM. The memory cells for data EEPROM are rated to endure thousands of erase/write cycles, up to 100K for EEPROM.

Data retention without refresh is conservatively estimated to be greater than 40 years.

The host should wait for the write cycle to complete and then verify the write by reading the byte(s).

1.8 RESET/POR

1.8.1 RESET PIN

The \overline{RST} pin provides a method for triggering an external Reset of the device. A Reset is generated by holding the pin low. These devices have a noise filter in the Reset path which detects and ignores small pulses.

1.8.2 POR

A POR pulse is generated on-chip whenever VDD rises above a certain threshold. This allows the device to start in the initialized state when VDD is adequate for operation.

To take advantage of the POR circuitry, tie the \overline{RST} pin through a resistor (1 kOhm to 10 kOhm) to VDD. This will eliminate external RC components usually needed to create a POR delay.

When the device starts normal operation (i.e., exits the Reset condition), device operating parameters (voltage, frequency, temperature, etc.) must be met to ensure operation. If these conditions are not achieved, the device must be held in Reset until the operating conditions are met.

1.9 Oscillator

The input clock must be 12 MHz to provide the proper frequency for the USB module.

USB full-speed is nominally 12 Mb/s. The clock input accuracy is $\pm 0.25\%$ (2,500 ppm maximum).

FIGURE 1-6: QUARTZ CRYSTAL OPERATION

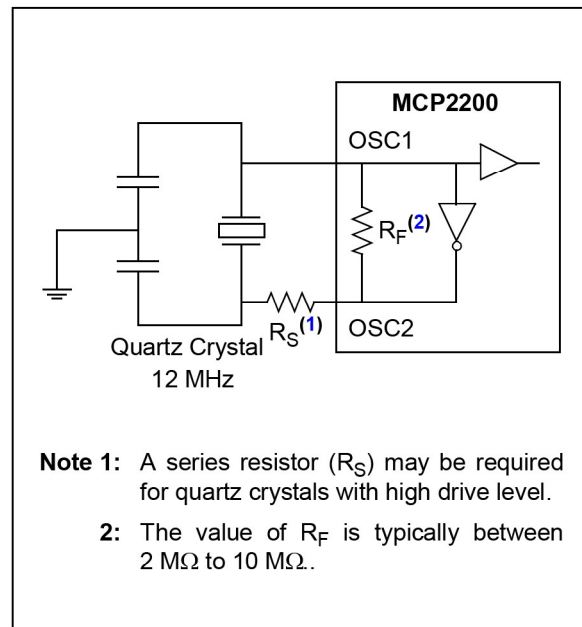
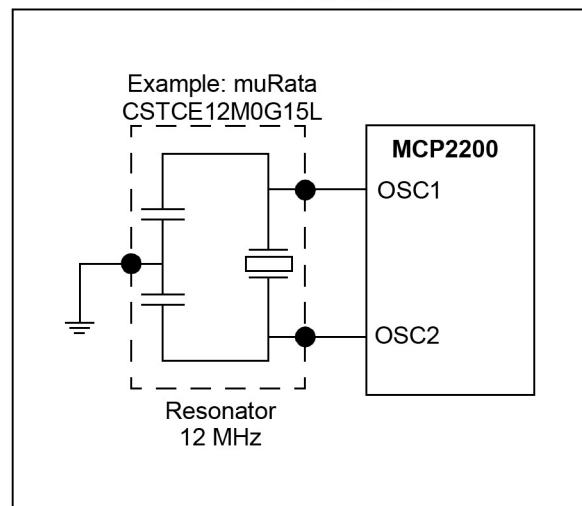

FIGURE 1-7: CERAMIC RESONATOR OPERATION



2.0 CONFIGURATION

The MCP2200 is configured by writing special commands using the HID interface. Configuration can be achieved using the configuration utility provided by Microchip. Alternatively, a custom utility can be developed by using the DLL available on the MCP2200 product page.

2.1 Configuration Utility

The configuration utility provided by Microchip allows the user to configure the MCP2200 to custom defaults. The configuration utility (shown in [Figure 2-1](#)) connects to the device's HID interface, where all of the configurable features can be set.

2.2 Serial String

The MCP2200 is supplied from the factory with a serialized USB serial string.

TABLE 2-1: CONFIGURATION DESCRIPTIONS

Configuration Name	Description
Vendor ID (0x04D8)	The USB vendor identification assigned to Microchip by the USB consortium.
Product ID (0x00DF)	Device ID assigned by Microchip. The device can be used "as-is", or Microchip can assign a custom PID by request.
Baud Rate	Sets the UART baud rate using a list of primary baud rates. See the UART section for details on setting non-primary baud rates.
IO Config	Individually configures the I/O to inputs or outputs.
IO Default	Individually configures the output default state for pins configured as outputs.
Tx/Rx LEDs	Enables/disables the GP6 and GP7 pins to function as USB traffic indicators. Pins are active low when configured as traffic indicators.
Hardware Flow Control	Enables/disables $\overline{\text{CTS}}$ and $\overline{\text{RTS}}$ flow control.
USBCFG Pin	Enables/disables the GP1 pin as a USB configuration status indicator.
Suspend Pin	Enables/disables the GP0 pin as a USB suspend status pin.
Invert Sense	Enables/disables the UART lines states: <ul style="list-style-type: none"> - Normal – Tx/Rx idle high; $\overline{\text{CTS}}/\overline{\text{RTS}}$ active low - Inverted – Tx/Rx idle low; $\overline{\text{CTS}}/\overline{\text{RTS}}$ active high
Manufacturer String	USB manufacturer string.
Product String	USB product string.

MCP2200

FIGURE 2-1: CONFIGURATION UTILITY

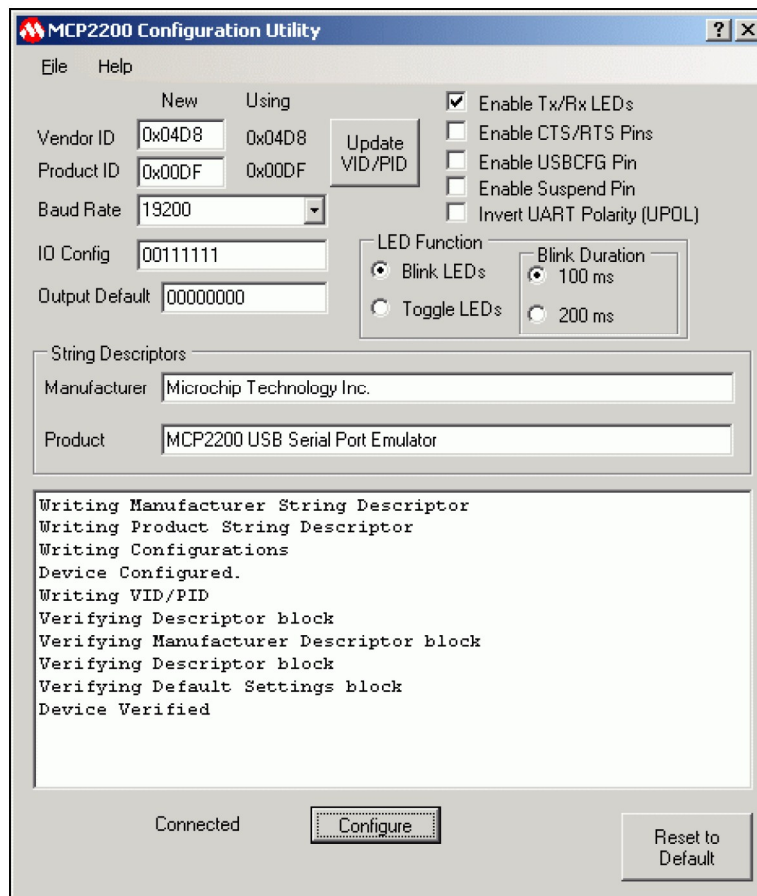

2.3 Simple Configuration and I/O DLL

To help the user develop a custom configurator, Microchip provides a DLL that uses Microsoft®.NET Framework 3.5. There is documentation about drivers and utilities on the MCP2200 product page at www.microchip.com (in the Software section) with information on associating the DLL with a Visual C++ project.

2.3.1 SIMPLE I/O DLL CALLS

Table 2-2 lists the functions provided by the DLL to allow the configuration of the device and control of the I/O.

TABLE 2-2: CONFIGURATION FUNCTIONS

Category and Function Name
Initialization (Note 1)
<code>void InitMCP2200(VID, PID)</code>
Configuration (Note 2)
<code>bool ConfigureIO(mask)</code>
<code>bool ConfigureIoDefaultOutput(mask, defaultGpioOutputValue)</code>
<code>bool fnRxLED (OFF/TOGGLE/BLINKSLOW/BLINKFAST)</code>
<code>bool fnTxLED (OFF/TOGGLE/BLINKSLOW/BLINKFAST)</code>
<code>bool fnHardwareFlowControl (ON/OFF)</code>
<code>bool fnULoad(ON/OFF)</code>
<code>bool fnSuspend (ON/OFF)</code>
<code>bool ConfigureMCP2200(mask, baudrate, RxLedMode, TxLedMode, flowCtrl, ULoad, suspend)</code>
<code>bool ConfigureIO(mask)</code>
Miscellaneous
<code>String^ GetDeviceInfo(deviceIndex)</code>
<code>unsigned int GetNoOfDevices()</code>
<code>int GetSelectedDevice()</code>
<code>String^ GetSelectedDeviceInfo()</code>
<code>bool IsConnected()</code>
<code>int SelectDevice(uiDeviceNo)</code>
<code>int ReadEEPROM(uiEEPAddress)</code>
<code>int WriteEEPROM(uiEEPAddress, ucValue)</code>
I/O Control
<code>bool ClearPin(pinnumber)</code>
<code>bool SetPin(pinnumber)</code>
<code>bool ReadPin(pinnumber, *pinvalue)</code>
<code>int ReadPinValue(pinnumber)</code>
<code>bool ReadPort(*portValue)</code>
<code>int ReadPortValue()</code>
<code>bool WritePort(portValue)</code>
Summary
<code>bool SimpleIOClass::ClearPin(unsigned int pin)</code> Section 2.3.1.1
<code>bool SimpleIOClass::ConfigureIO (unsigned char IOMap)</code> Section 2.3.1.2
<code>bool SimpleIOClass::ConfigureIoDefaultOutput(unsigned char ucIoMap, unsigned char ucDefValue)</code> Section 2.3.1.3
<code>bool SimpleIOClass::ConfigureMCP2200 (unsigned char IOMap, unsigned long BaudRateParam, unsigned int RxLEDMode, unsigned int TxLEDMode, bool FLOW, bool ULOAD, bool SSPND)</code> Section 2.3.1.4
<code>bool SimpleIOClass::fnHardwareFlowControl (unsigned int onOff)</code> Section 2.3.1.5

Note 1: Prior to any DLL API usage, a call to the `InitMCP2200()` function is needed. This function is the only initialization function in the presented DLL.

2: The configuration only needs to be set a single time – it is stored in NVM.

MCP2200

TABLE 2-2: CONFIGURATION FUNCTIONS (CONTINUED)

Category and Function Name	
Summary (Continued)	
bool SimpleIOClass::fnRxLED (unsigned int mode)	Section 2.3.1.6
bool SimpleIOClass::fnSetBaudRate (unsigned long BaudRateParam)	Section 2.3.1.7
bool SimpleIOClass::fnSuspend(unsigned int onOff)	Section 2.3.1.8
bool SimpleIOClass::fnTxLED (unsigned int mode)	Section 2.3.1.9
bool SimpleIOClass::fnULoad(unsigned int onOff)	Section 2.3.1.10
String^ SimpleIOClass::GetDeviceInfo(unsigned int uiDeviceNo)	Section 2.3.1.11
unsigned int SimpleIOClass::GetNoOfDevices(void)	Section 2.3.1.12
int SimpleIOClass::GetSelectedDevice(void)	Section 2.3.1.13
String^ SimpleIOClass::GetSelectedDeviceInfo(void)	Section 2.3.1.14
void SimpleIOClass::InitMCP2200 (unsigned int VendorID, unsigned int ProductID)	Section 2.3.1.15
bool SimpleIOClass::IsConnected()	Section 2.3.1.16
int SimpleIOClass::ReadEEPROM(unsigned int uiEEPAddress)	Section 2.3.1.17
bool SimpleIOClass::ReadPin(unsigned int pin, unsigned int *returnvalue)	Section 2.3.1.18
int SimpleIOClass::ReadPinValue(unsigned int pin)	Section 2.3.1.19
bool SimpleIOClass::ReadPort(unsigned int *returnvalue)	Section 2.3.1.20
int SimpleIOClass::ReadPortValue()	Section 2.3.1.21
int SimpleIOClass::SelectDevice(unsigned int uiDeviceNo)	Section 2.3.1.22
bool SimpleIOClass::SetPin(unsigned int pin)	Section 2.3.1.23
int SimpleIOClass::WriteEEPROM(unsigned int uiEEPAddress, unsigned char ucValue)	Section 2.3.1.24
bool SimpleIOClass::WritePort(unsigned int portValue)	Section 2.3.1.25
Constants	
const unsigned int OFF = 0;	
const unsigned int ON = 1;	
const unsigned int TOGGLE = 3;	
const unsigned int BLINKSLOW = 4;	
const unsigned int BLINKFAST = 5;	

Note 1: Prior to any DLL API usage, a call to the `InitMCP2200()` function is needed. This function is the only initialization function in the presented DLL.

2: The configuration only needs to be set a single time – it is stored in NVM.

2.3.1.1 ClearPin

Function:

bool SimpleIOClass::ClearPin (unsigned int pin)

Summary: Clears the specified pin.

Description: Clears the specified pin to logic '0'.

Precondition: This pin must be previously configured as an output via a `ConfigureIO` or `ConfigureIoDefaultOutput` call.

Parameters: `pin` - The pin number to set (0-7).

Returns: This function returns True if the transmission is successful and returns False if the transmission fails.

Remarks: None

EXAMPLE 2-1:

```

if (SimpleIOClass::ClearPin (2))
{
    lblStatusBar->Text = "Success";
}
else
    lblStatusBar->Text = "Invalid command " + SimpleIOClass::LastError;

```

2.3.1.2 ConfigureIO

Function:

```
bool SimpleIOClass::ConfigureIO (unsigned char IOMap)
```

Summary: Configures the GPIO pins for Digital Input, Digital Output.

Description: GPIO Pins can be configured as Digital Input, Digital Output.

Precondition: VID and PID must be previously set via a call to `InitMCP2200(VID, PID)`.

Parameters:

IOMap - a byte that represents a bitmap of the GPIO configuration:

- a bit set to '1' will be a digital input
- a bit set to '0' will be a digital output
- MSB - - - - - LSB
GP7 GP6 GP5 GP4 GP3 GP2 GP1 GP0

Returns: This function returns True if the transmission is successful and returns False if the transmission fails.

Remarks: Error code is returned in `LastError`.

EXAMPLE 2-2:

```
if (SimpleIOClass::ConfigureIO(0xA5) == SUCCESS)
    lblStatusBar->Text = "Success";
else
    lblStatusBar->Text = "Invalid command " + SimpleIOClass::LastError;
```

2.3.1.3 ConfigureIoDefaultOutput

Function:

```
bool SimpleIOClass::ConfigureIoDefaultOutput (unsigned char ucIoMap, unsigned char ucDefValue)
```

Summary: Configures the IO pins for Digital Input, Digital Output and also the default output latch value.

Description: IO Pins can be configured as Digital Input, Digital Output. The default output latch value is received as a parameter.

Precondition: VID and PID must be previously set via a call to `InitMCP2200(VID, PID)`.

Parameters:

1. **ucIoMap** - a byte that represents a bitmap used to set the GPIOs as either input or output.
 - '1' configures GPIO as input
 - '0' configures GPIO as output
 - MSB - - - - - LSB
GP7 GP6 GP5 GP4 GP3 GP2 GP1 GP0
2. **ucDefValue** - the default value that will be loaded to the output latch (affects only the pins configured as outputs).

Returns: This function returns True if the transmission is successful and returns False if the transmission fails.

Remarks: Error code is returned in `LastError`.

EXAMPLE 2-3:

```
if (SimpleIOClass::ConfigureIoDefaultOutput(IoMap, DefValue) == SUCCESS)
    lblStatusBar->Text = "Success";
else
    lblStatusBar->Text = "Invalid command " + SimpleIOClass::LastError;
```

MCP2200

2.3.1.4 ConfigureMCP2200

Function:

```
bool SimpleIOClass::ConfigureIoDefaultOutput (unsigned long BaudRateParam, unsigned int RxLEDMoDe, unsigned int TxLEDMoDe, bool FLOW, bool ULOAD, bool SSPND)
```

Summary: Configures the device.

Description: Sets the default GPIO designation, baud rate, TX/RX LED modes, flow control.

Precondition: VID and PID must be previously set via a call to `InitMCP2200(VID, PID)`.

Parameters:

1. `IOMap` - A byte which represents the input/output state of the pins (each bit may be either a '1' for input, and '0' for output).
2. `BaudRateParam` - the default communication baud rate.
3. `RxLEDMoDe` - can take one of the constant values (`OFF`, `ON`, `TOGGLE`, `BLINKSLOW`, `BLINKFAST`) to define the behavior of the Rx LED.
 - `OFF = 0`
 - `ON = 1`
 - `TOGGLE = 3`
 - `BLINKSLOW = 4`
 - `BLINKFAST = 5`
4. `TxLEDMoDe` - can take one of the defined values (`OFF`, `ON`, `TOGGLE`, `BLINKSLOW`, `BLINKFAST`) in order to define the behavior of the Tx LED.
5. `FLOW` - this parameter establishes the default flow control method (False - no HW flow control, True - $\overline{\text{RTS}}/\overline{\text{CTS}}$ flow control).
6. `ULOAD` - this parameter establishes when USB has loaded the configuration.
7. `SSPND` - this parameter establishes when USB send us the Suspend mode.

Returns: This function returns True if the transmission is successful and returns False if the transmission fails.

Remarks: None.

EXAMPLE 2-4:

```
if (SimpleIOClass::ConfigureMCP2200(0x43, 9600, BLINKSLOW, BLINKFAST, false, false, false) == SUCCESS)
    lblStatusBar->Text = "Success";
else
    lblStatusBar->Text = "Invalid command "
```

2.3.1.5 fnHardwareFlowControl

Function:

```
bool SimpleIOClass::fnHardwareFlowControl (unsigned int onOff)
```

Summary: Configures the flow control of the MCP2200. The flow control configuration will be stored in NVRAM.

Description: Sets the flow control to HW flow control ($\overline{\text{RTS}}/\overline{\text{CTS}}$) or No flow control.

Precondition: VID and PID must be previously set via a call to `InitMCP2200(VID, PID)`.

Parameters: `onOff`:

- '1' if HW flow control is required
- '0' if no flow control is required

Returns: This function returns True if the transmission is successful and returns False if the transmission fails.

Remarks: Error code is returned in `LastError`.

EXAMPLE 2-5:

```
if (SimpleIOClass::fnHardwareFlowControl(1) == SUCCESS)
    lblStatusBar->Text = "Success";
else
    lblStatusBar->Text = "Invalid command " + SimpleIOClass::LastError;
```

2.3.1.6 fnRxLED

Function:

```
bool SimpleIOClass::fnRxLED (unsigned int mode)
```

- Summary:** Configures the Rx LED mode. Rx LED configuration will be stored in NVRAM.
- Description:** Sets the Rx LED mode to one of the possible values.
- Precondition:** VID and PID must be previously set via a call to `InitMCP2200(VID, PID)`.
- Parameters:** `mode (constant): OFF, TOGGLE, BLINKSLOW, BLINKFAST`
- Returns:** This function returns True if the transmission is successful and returns False if the transmission fails.
- Remarks:** Error code is returned in `LastError`.

EXAMPLE 2-6:

```
if (SimpleIOClass::fnRxLED (BLINKFAST) == SUCCESS)
    lblStatusBar->Text = "Success";
else
    lblStatusBar->Text = "Invalid command " + SimpleIOClass::LastError;
```

2.3.1.7 fnSetBaudRate

Function:

```
bool SimpleIOClass::fnSetBaudRate (unsigned long BaudRateParam)
```

- Summary:** Configures the device's default baud rate. The baud rate value will be stored in NVRAM
- Description:** Sets the desired baud rate and it will store it into device's NVRAM.
- Precondition:** VID and PID must be previously set via a call to `InitMCP2200(VID, PID)`.
- Parameters:** `BaudRateParam` - the desired baud rate value
- Returns:** This function returns True if the transmission is successful and returns False if the transmission fails.
- Remarks:** Error code is returned in `LastError`. This function is used only to set the default power-up baud rate value. When used with a terminal program, there is no need to call this function to change the baud rate. Changing the baud rate from the terminal program, will send the appropriate CDC packet that will change the communication's baud rate without the need to call this function.

EXAMPLE 2-7:

```
if (SimpleIOClass::fnSetBaudRate(9600) == SUCCESS)
    lblStatusBar->Text = "Success";
else
    lblStatusBar->Text = "Invalid command " + SimpleIOClass::LastError;
```

2.3.1.8 fnSuspend

Function:

```
bool SimpleIOClass::fnSuspend (unsigned int onOff)
```

- Summary:** Configures the GP0 pin of the MCP2200 to show the status of Suspend/Resume USB states.
- Description:** When the GP0 is designated to show the USB Suspend/Resume states, the pin will go low when the Suspend state is issued, or will go high when the Resume state is on.
- Precondition:** VID and PID must be previously set via a call to `InitMCP2200(VID, PID)`.
- Parameters:** `onOff:`
- '1' GP0 will reflect the USB Suspend/Resume states
 - '0' GP0 will not reflect the USB Suspend/Resume states (can be used as GPIO)
- Returns:** This function returns True if the transmission is successful and returns False if the transmission fails.
- Remarks:** Error code is returned in `LastError`.

MCP2200

EXAMPLE 2-8:

```
if (SimpleIOClass::fnSuspend(1) == SUCCESS)
    lblStatusBar->Text = "Success";
else
    lblStatusBar->Text = "Invalid command " + SimpleIOClass::LastError;
```

2.3.1.9 fnTxLED

Function:

bool SimpleIOClass::fnTxLED (unsigned int mode)

Summary: Configures the Tx LED mode. Tx LED configuration will be stored in NVRAM.

Description: Sets the Tx LED mode to one of the possible values.

Precondition: VID and PID must be previously set via a call to `InitMCP2200(VID, PID)`.

Parameters: mode (constant): OFF, TOGGLE, BLINKSLOW, BLINKFAST

Returns: This function returns True if the transmission is successful and returns False if the transmission fails.

Remarks: Error code is returned in `LastError`.

EXAMPLE 2-9:

```
if (SimpleIOClass::fnTxLED (BLINKSLOW) == SUCCESS)
    lblStatusBar->Text = "Success";
else
    lblStatusBar->Text = "Invalid command " + SimpleIOClass::LastError;
```

2.3.1.10 fnULoad

Function:

bool SimpleIOClass::fnULoad (unsigned int onOff)

Summary: Configures the GP1 pin of the MCP2200 to show the status of the USB configuration.

Description: When the GP1 is designated to show the USB configuration status, the pin will start low (during power-up or after Reset), and it will go high after the MCP2200 is successfully configured by the host.

Precondition: VID and PID must be previously set via a call to `InitMCP2200(VID, PID)`.

Parameters: onOff:

- '1' GP1 will reflect the USB configuration status
- '0' GP1 will not reflect the USB configuration status (can be used as GPIO)

Returns: This function returns True if the transmission is successful and returns False if the transmission fails.

Remarks: Error code is returned in `LastError`.

EXAMPLE 2-10:

```
if (SimpleIOClass::fnULoad(1) == SUCCESS)
    lblStatusBar->Text = "Success";
else
    lblStatusBar->Text = "Invalid command " + SimpleIOClass::LastError;
```

2.3.1.11 GetDeviceInfo

Function:

```
String^ SimpleIOClass::GetDeviceInfo (unsigned int uiDeviceNo)
```

Summary: Returns the path name for one of the connected devices.

Description: The function will return the path name for the given device ID.

Precondition: At least one call to the `InitMCP2200()` is required in order to initiate a DLL search for the compatible devices.

VID and PID must be previously set via a call to `InitMCP2200(VID, PID)`.

Parameters: `uiDeviceNo`: The device ID for which the path information is needed. Can have a value between 0 and the number of devices minus 1.

Returns: This function returns a string containing the path name of the given device id.

- In the case the given ID is out of range, the function will return the "Device Index Error" string.
- In the case the device for which the path name is required is not connected anymore, the return string will be "Device Not Connected".

Remarks: None.

EXAMPLE 2-11:

```
lblStatusBar->Text = SimpleIOClass::GetDeviceInfo(0);
```

2.3.1.12 GetNoOfDevices

Function:

```
unsigned int SimpleIOClass::GetNoOfDevices(void)
```

Summary: The function returns the number of available devices present in the system.

Description: The function returns the number of HID devices (with the given VID/PID) connected to the system.

Precondition: At least one call to the `InitMCP2200()` is required in order to initiate a DLL search for the compatible devices. Also, in order to know the actual number of devices connected to the system, call the `SimpleIOClass::IsConnected()` function. VID and PID must be previously set via a call to `InitMCP2200(VID, PID)`.

Parameters: None.

Returns: This function returns the number of HID devices with the given VID/PID (as parameters of `SimpleIOClass::InitMCP2200()` function).

Remarks: Call the `SimpleIOClass::IsConnected()` prior to the call of this function in order to have the most recent number of devices that are present in the system.

EXAMPLE 2-12:

```
SimpleIOClass::IsConnected(); //call this function to refresh the number of
//the devices present in the system
lblStatusBar->Text = SimpleIOClass::GetNoOfDevices();
```

2.3.1.13 GetSelectedDevice

Function:

```
int SimpleIOClass::GetSelectedDevice(void)
```

Summary: Returns the ID of the selected device

Description: The function returns the ID of the current selected device.

Precondition: At least one call to the `InitMCP2200()` is required in order to initiate a DLL search for the compatible devices. VID and PID must be previously set via a call to `InitMCP2200(VID, PID)`.

Parameters: None.

Returns: This function returns the ID of the current selected device. Its value can range from 0 to the number of devices minus 1.

Remarks: None.

MCP2200

EXAMPLE 2-13:

```
lblStatusBar->Text = SimpleIOClass::GetSelectedDevice();
```

2.3.1.14 GetSelectedDeviceInfo

Function:

```
String^ SimpleIOClass::GetSelectedDeviceInfo(void)
```

Summary: Returns the selected device path name.

Description: The function returns a string containing the unique path name of the selected device.

Precondition: At least one call to the `InitMCP2200()` is required in order to initiate a DLL search for the compatible devices. VID and PID must be previously set via a call to `InitMCP2200(VID, PID)`.

Parameters: None.

Returns: This function returns a string containing the unique path name of the selected device.

Remarks: The default selected device is the first one that the DLL finds. If the user wants to retrieve other devices path names (assuming more than one device is present in the system), a call to `SimpleIOClass::SelectDevice(deviceNo)` is required.

EXAMPLE 2-14:

```
lblStatusBar->Text = SimpleIOClass::GetSelectedDeviceInfo(void)
```

2.3.1.15 InitMCP2200

Function:

```
void SimpleIOClass::InitMCP2200 (unsigned int VendorID, unsigned int ProductID)
```

Summary: Configures the Simple IO class for a specific Vendor and product ID.

Description: Sets the Vendor and Product ID used for the project.

Precondition: None.

Parameters:

1. `Vendor ID` - assigned by USB IF (www.usb.org)
2. `Product ID` - assigned by the Vendor ID Holder

Returns: None.

Remarks: Call this function before any other calls, to set the Vendor and Product IDs.

EXAMPLE 2-15:

```
InitMCP2200 (0x4D8, 0x00DF);
```

2.3.1.16 IsConnected

Function:

```
bool SimpleIOClass::IsConnected()
```

Summary: Checks with the OS if the current VID/PID device is connected.

Description: Checks if a MCP2200 is connected to the computer. If so, it returns True, otherwise the result will be False.

Precondition: VID and PID must be previously set via a call to `InitMCP2200(VID, PID)`.

Parameters: None.

Returns: True - if at least one device is connected to the host.
False - if there are no devices connected to the host.

Remarks: No actual communication with the end device is occurring. The function inquires the OS if the specified VID/PID was enumerated.

EXAMPLE 2-16:

```
unsigned int rv;
if (SimpleIOClass::IsConnected ())
{
    lblStatusBar->Text = "Device connected";
}
else
    lblStatusBar->Text = "Device Disconnected";
```

2.3.1.17 ReadEEPROM

Function:

```
int SimpleIOClass::ReadEEPROM (unsigned int uiEEPAddress)
```

Summary: Reads a byte from the EEPROM.

Description: Reads a byte from the EEPROM at the given address.

Precondition: At least one call to the `InitMCP2200()` is required in order to initiate a DLL search for the compatible devices. VID and PID must be previously set via a call to `InitMCP2200(VID, PID)`.

Parameters: `uiEEPAddress` - the EEPROM address location we need to write to (must be from 0 to 255, inclusively).

Returns: This function returns any positive value as being the EEPROM's location value:

- `E_WRONG_ADDRESS` (-3) - in case the given EEPROM address is out of range
- `E_CANNOT_SEND_DATA` (-4) - in case the function cannot send the command to the device

Remarks: None.

EXAMPLE 2-17:

```
int iRetValue = SimpleIOClass::ReadEEPROM(0x01);
if (iRetValue >= 0)
{
    lblStatusBar->Text = "Success";
}
else
    lblStatusBar->Text = "Error reading to EEPROM" + SimpleIOClass::LastError;
```

2.3.1.18 ReadPin

Function:

```
bool SimpleIOClass::ReadPin (unsigned int pin, unsigned int *returnvalue)
```

Summary: Reads the specified pin.

Description: Reads the specified pin and returns the value in `returnvalue`. If the pin has been configured as a digital input, the return value will be either '0' or '1'.

Precondition: Must be previously configured as an input via a `ConfigureIO` call. VID and PID must be previously set via a call to `InitMCP2200(VID, PID)`.

Parameters:

- `pin` - the pin number to set (0-7)
- `returnvalue` - the value read on the pin ('0' or '1')

Returns: This function returns True if the transmission is successful and returns False if the transmission fails.

Remarks: None.

EXAMPLE 2-18:

```
unsigned int rv;
if (SimpleIOClass::ReadGPIOOn (0, &rv))
{
    lblStatusBar->Text = "Success";
}
else
    lblStatusBar->Text = "Invalid command " + SimpleIOClass::LastError;
```

MCP2200

2.3.1.19 ReadPinValue

Function:

```
int SimpleIOClass::ReadPinValue(unsigned int pin)
```

Summary: Reads the specified pin.

Description: Reads the specified pin and returns the value as the return value. If the pin has been configured as a digital input, the return value will be either '0' or '1'. If an error occurs, the function will return a value of 0x8000.

Precondition: Must be previously configured as an input via a `ConfigureIO` call. VID and PID must be previously set via a call to `InitMCP2200(VID, PID)`.

Parameters: `pin` - the pin number to set (0-7)

Returns: This function returns the read value of the pin, or returns a value of 0x8000, if an error occurs.

Remarks: None.

EXAMPLE 2-19:

```
unsigned int rv;
if (SimpleIOClass::ReadPinValue(0) != 0x8000)
{
    lblStatusBar->Text = "Success";
}
else
    lblStatusBar->Text = "Invalid command " + SimpleIOClass::LastError;
```

2.3.1.20 ReadPort

Function:

```
bool SimpleIOClass::ReadPort(unsigned int *returnvalue)
```

Summary: Reads the GPIO port as digital input.

Description: Reads the GPIO port and returns the value in `returnvalue`. This provides a means to read all pins simultaneously, instead of one-by-one.

Precondition: Must be previously configured as an input via a `ConfigureIO` call. VID and PID must be previously set via a call to `InitMCP2200(VID, PID)`.

Parameters:

- `pin` - the pin number to set (0-7)
- `returnvalue` - the value read on the pin ('0' or '1')

Returns: This function returns True if the transmission is successful and returns False if the transmission fails.

Remarks: Pins configured for output return the current state of the port. Pins configured as input read as zero.

EXAMPLE 2-20:

```
unsigned int rv;
if (SimpleIOClass::ReadGPIOPort (0, &rv))
{
    lblStatusBar->Text = "Success";
}
else
    lblStatusBar->Text = "Invalid command " + SimpleIOClass::LastError;
```

2.3.1.21 ReadPortValue

Function:

```
int SimpleIOClass::ReadPortValue()
```

Summary: Reads the GPIO port as digital input.

Description: Reads the GPIO port and returns the value of the port. This provides a method to read all pins simultaneously, instead of one-by-one. In case of an error, the returned value will be 0x8000.

Precondition: Must be previously configured as an input via a `ConfigureIO` call. VID and PID must be previously set via a call to `InitMCP2200(VID, PID)`.

Parameters: None.

Returns: This function returns True if the transmission is successful and returns False if the transmission fails.

Remarks: Pins configured for output return the current state of the port. Pins configured as input read as zero.

EXAMPLE 2-21:

```
int rv;
rv = SimpleIOClass::ReadPortValue()
if (rv != 0x8000)
{
    lblStatusBar->Text = "Success";
}
else
    lblStatusBar->Text = "Invalid command " + SimpleIOClass::LastError;
```

2.3.1.22 SelectDevice

Function:

```
int SimpleIOClass::SelectDevice(unsigned int uiDeviceNo)
```

Summary: Selects one of the active devices in the system.

Description: The function is used to select one of the detected devices in the system as the "active device".

Precondition: At least one call to the `InitMCP2200()` is required in order to initiate a DLL search for the compatible devices. Also, in order to know the actual number of devices in the system, call the `SimpleIOClass::IsConnected()` function. VID and PID must be previously set via a call to `InitMCP2200(VID, PID)`.

Parameters: `uiDeviceNo` - the ID of the device to be selected (can have a value between 0 and the number of devices minus 1).

Returns: This function returns '0' in case of selection success, otherwise it will return:

- `E_WRONG_DEVICE_ID` (-1) for a device ID that is out of range
- `E_INACTIVE_DEVICE` (-2) for an inactive device.

Remarks: Call the `SimpleIOClass::IsConnected()` prior to the call of this function in order to have the most recent number of devices that are present in the system.

EXAMPLE 2-22:

```
int iResult;
iResult = SimpleIOClass::SelectDevice(1)
if (iResult == 0)
{
    lblStatusBar->Text = "Success";
}
else
    lblStatusBar->Text = "Error selecting device";
```

MCP2200

2.3.1.23 SetPin

Function:

```
bool SimpleIOClass::SetPin(unsigned int pin)
```

Summary: Sets the specified pin.

Description: Sets the specified pin to logic '1'.

Precondition: Must be previously configured as an output via a `ConfigureIO` or `ConfigureIODefaultOutput` call. VID and PID must be previously set via a call to `InitMCP2200(VID, PID)`.

Parameters: `pin` - the pin number to set (0-7)

Returns: This function returns `True` if the transmission is successful and returns `False` if the transmission fails.

Remarks: None.

EXAMPLE 2-23:

```
if (SimpleIOClass::SetPin (2))
{
    lblStatusBar->Text = "Success";
}
else
    lblStatusBar->Text = "Invalid command " + SimpleIOClass::LastError;
```

2.3.1.24 WriteEEPROM

Function:

```
int SimpleIOClass::WriteEEPROM(unsigned int uiEEPAddress, unsigned char ucValue)
```

Summary: Writes a byte into the MCP2200's EEPROM.

Description: Writes a byte at the given address into the internal 256 bytes EEPROM.

Precondition: At least one call to the `InitMCP2200()` is required in order to initiate a DLL search for the compatible devices. VID and PID must be previously set via a call to `InitMCP2200(VID, PID)`.

Parameters:

- `uiEEPAddress` - the EEPROM address location we need to write to (must be from 0 to 255 inclusively).
- `ucValue` - the byte value required for writing to the given location.

Returns: This function returns '0' if the write command was successfully sent to the device, otherwise it returns:

- `E_WRONG_ADDRESS` (-3) in case the given EEPROM address is out of range
- `E_CANNOT_SEND_DATA` (-4) in case the function cannot send the command to the device.

Remarks: The function will send the write EEPROM command, but has no confirmation whether the EEPROM location was actually written. In order to verify the correctness of the EEPROM write, the user can issue a `SimpleIOClass::ReadEEPROM()` and check if the returned value matches the written one.

EXAMPLE 2-24:

```
int iRetVal = SimpleIOClass::WriteEEPROM(0x01, 0xAB);

if (iRetVal == 0)
{
    lblStatusBar->Text = "Success";
}
else
    lblStatusBar->Text = "Error writting to EEPROM" + SimpleIOClass::LastError;
```

2.3.1.25 WritePort

Function:

```
bool SimpleIOClass::WritePort(unsigned int portValue)
```

Summary: Writes a value to the GPIO port.

Description: Writes the GPIO port. This provides a means to write all pins at simultaneously, instead of one-by-one.

Precondition: Must be previously configured as an output via a `ConfigureIO` call. VID and PID must be previously set via a call to `InitMCP2200(VID, PID)`.

Parameters: `portValue` - byte value to set on the port.

Returns: This function returns `True` if the transmission is successful and returns `False` if the transmission fails.

Remarks: None.

EXAMPLE 2-25:

```
if (SimpleIOClass::WritePort (0x5A))
{
    lblStatusBar->Text = "Success";
}
else
    lblStatusBar->Text = "Invalid command " + SimpleIOClass::LastError;
```

MCP2200

NOTES:

3.0 ELECTRICAL CHARACTERISTICS

Absolute Maximum Ratings (†)

Ambient temperature under bias	-40°C to +85°C
Storage temperature	-65°C to +150°C
Voltage on VDD with respect to VSS	-0.3V to +6.0V
Voltage on $\overline{\text{MCLR}}$ with respect to VSS	-0.3V to +9.0V
Voltage on VUSB pin with respect to VSS	-0.3V to +4.0V
Voltage on D+ and D- pins with respect to VSS	-0.3V to (VUSB + 0.3V)
Voltage on all other pins with respect to VSS	-0.3V to (VDD + 0.3V)
Total power dissipation ⁽¹⁾	800 mW
Maximum current out of VSS pin	95 mA
Maximum current into VDD pin	95 mA
Clamp current, I _K (V _{PIN} < 0 or V _{PIN} > VDD).....	± 20 mA
Maximum output current sunk by any I/O pin.....	25 mA
Maximum output current sourced by any I/O pin	25 mA
Maximum current sunk by all ports	90 mA
Maximum current sourced by all ports	90 mA

Note 1: Power dissipation is calculated as follows: $P_{DIS} = V_{DD} \times \{I_{DD} - \sum I_{OH}\} + \sum \{(V_{DD} - V_{OH}) \times I_{OH}\} + \sum (V_{OL} \times I_{OL})$.

2: V_{USB} must always be $\leq V_{DD} + 0.3V$

† **NOTICE:** Stresses above those listed under “Absolute Maximum Ratings” may cause permanent damage to the device. This is a stress rating only and functional operation of the device at those or any other conditions above those indicated in the operation listings of this specification is not implied. Exposure above maximum rating conditions for extended periods may affect device reliability.

MCP2200

3.1 DC CHARACTERISTICS

DC Characteristics		Operating Conditions (unless otherwise indicated): 3.0V ≤ VDD ≤ 5.5V at -40°C ≤ TA ≤ +85°C (I-Temp)					
Param No.	Characteristic	Sym	Min	Typ	Max	Units	Conditions
D001	Supply Voltage	VDD	3.0	—	5.5	V	
	Power-on Reset Release Voltage	VPOR		1.6		V	
	Power-on Reset Rearm Voltage			0.8		V	
D003	VDD Rise Rate to Ensure Power-on Reset	SVDD	0.05	—	—	V/ms	Design guidance only Not tested
D004	Supply Current	IDD					
	VDD = 3.0V		—	10	12	mA	Fosc = 12 MHz, (330 nF on VUSB)
VDD = 5.0V		—	13	15	mA		
D005	Standby current	IDDS	—	9	—	μA	
Input Low-Voltage							
D031	Schmitt Trigger (GPIO)	VIL	—	—	0.2 VDD	V	3.0V ≤ VDD ≤ 5.5V
	TTL ($\overline{\text{CTS}}$ pin)		—	—	0.8		4.5V ≤ VDD ≤ 5.5V
Input High-Voltage							
D041	Schmitt Trigger (GPIO)	VIH	0.8 VDD	—	VDD	V	3.0V ≤ VDD ≤ 5.5V
	TTL ($\overline{\text{RTS}}$ pin)		2.0	—	VDD		4.5V ≤ VDD ≤ 5.5V
Input Leakage Current							
D060	GPIO, $\overline{\text{CTS}}$	IIL	—	±50	±100	nA	Vss ≤ VPIN ≤ VDD, pin at Hi-Z
	$\overline{\text{RST}}$			±50	±200		
	OSC1			±50	±100		
Output Low-Voltage							
D080	GPIO, UART TX/RX	VOL	—	—	0.6	V	IoL = 8.0 mA, VDD = 5.0V
			—	—	0.6		IoL = 6.0 mA, VDD = 3.3V
Output High-Voltage							
D090	GPIO, UART TX/RX	VOH	VDD - 0.7	—	—	V	IoH = -3.5 mA, VDD = 5.0V
			VDD - 0.7	—	—		IoH = -3.0 mA, VDD = 3.3V
Capacitive Loading Specs on Output Pins							
D101	OSC2	Cosc2	—	—	15	pF	Note 1
D102	GPIO	Cio	—	—	50	pF	Note 1

Note 1: This parameter is characterized, but not tested.

FIGURE 3-1: POR AND POR REARM WITH SLOW RISING V_{DD}

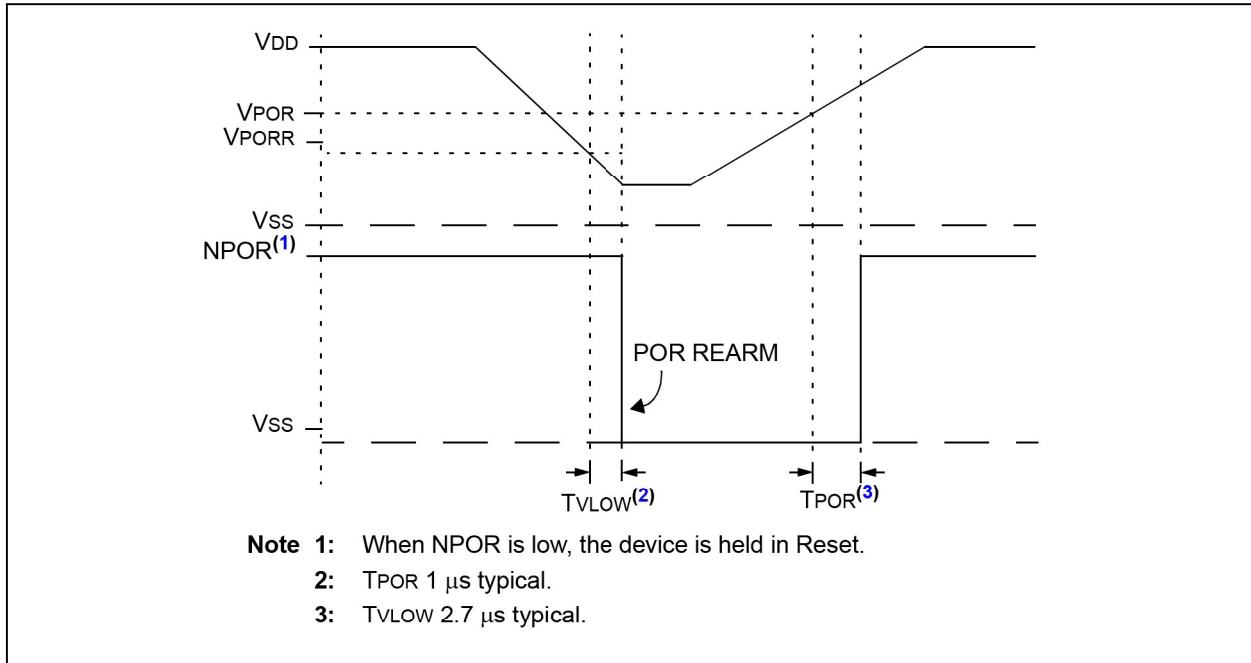

TABLE 3-1: USB MODULE SPECIFICATIONS

DC Characteristics		Operating Conditions (unless otherwise indicated): 3.0V \leq V _{DD} \leq 5.5V at -40°C \leq T _A \leq +85°C (I-Temp)					
Param No.	Characteristic	Sym	Min	Typ	Max	Units	Conditions
D313	USB Voltage	V _{USB}	3.0	—	3.6	V	Voltage on V _{USB} pin must be in this range for proper USB operation
D314	Input Leakage on Pin	I _{IL}	—	—	± 1	μ A	V _{SS} \leq V _{PIN} \leq V _{DD} pin at high-impedance
D315	Input Low Voltage for USB Buffer	V _{ILUSB}	—	—	0.8	V	For V _{USB} range
D316	Input High Voltage for USB Buffer	V _{IHUSB}	2.0	—	—	V	For V _{USB} range
D318	Differential Input Sensitivity	V _{DIFS}	—	—	0.2	V	The difference between D+ and D- must exceed this value while V _{CM} is met
D319	Differential Common Mode Range	V _{CM}	0.8	—	2.5	V	
D320	Driver Output Impedance ⁽¹⁾	Z _{OUT}	28	—	44	Ω	
D321	Voltage Output Low	V _{OL}	0.0	—	0.3	V	1.5 k Ω load connected to 3.6V
D322	Voltage Output High	V _{OH}	2.8	—	3.6	V	1.5 k Ω load connected to ground

Note 1: The D+ and D- signal lines have been built-in impedance matching resistors. No external resistors, capacitors or magnetic components are necessary on the D+/D- signal paths between the MCP2200 family device and the USB cable.

MCP2200

TABLE 3-2: THERMAL CONSIDERATIONS

Standard Operating Conditions (unless otherwise stated)					
Operating temperature $-40^{\circ}\text{C} \leq T_A \leq +85^{\circ}\text{C}$ (I-Temp)					
Param No.	Sym	Characteristic	Typ	Units	Conditions
TH01	θ_{JA}	Thermal Resistance Junction to Ambient	85.2	$^{\circ}\text{C}/\text{W}$	20-pin SOIC package
			108.1	$^{\circ}\text{C}/\text{W}$	20-pin SSOP package
			36.1	$^{\circ}\text{C}/\text{W}$	20-pin QFN 5x5 mm package
TH02	θ_{JC}	Thermal Resistance Junction to Case	24	$^{\circ}\text{C}/\text{W}$	20-pin SOIC package
			24	$^{\circ}\text{C}/\text{W}$	20-pin SSOP package
			1.7	$^{\circ}\text{C}/\text{W}$	20-pin QFN 5x5 mm package
TH03	T_{JMAX}	Maximum Junction Temperature	150	$^{\circ}\text{C}$	
TH04	PD	Power Dissipation	—	W	$PD = P_{INTERNAL} + P_{I/O}$
TH05	$P_{INTERNAL}$	Internal Power Dissipation	—	W	$P_{INTERNAL} = I_{DD} \times V_{DD}^{(1)}$
TH06	$P_{I/O}$	I/O Power Dissipation	—	W	$P_{I/O} = \sum (I_{OL} * V_{OL}) + \sum (I_{OH} * (V_{DD} - V_{OH}))$
TH07	P_{DER}	Derated Power	—	W	$P_{DER} = P_{D_{MAX}} (T_J - T_A) / \theta_{JA}^{(2,3)}$

Note 1: I_{DD} is the current to run the chip alone without driving any load on the output pins.

2: T_A = Ambient Temperature.

3: T_J = Junction Temperature.

3.2 AC Characteristics

3.2.1 TIMING PARAMETER SYMBOLOGY

The timing parameter symbols have been created in one of the following formats:

1. TppS2ppS

2. TppS

<p>T</p> <p>F Frequency</p> <p>E Error</p>	<p>T Time</p>
--	--------------------

Lowercase letters (pp) and their meanings:

<p>pp</p> <p>io Input or Output pin</p> <p>rx Receive</p> <p>bitclk RX/TX BITCLK</p> <p>drt Device Reset Timer</p>	<p>osc Oscillator</p> <p>tx Transmit</p> <p>RST Reset</p>
---	--

Uppercase letters and their meanings:

<p>S</p> <p>F Fall</p> <p>H High</p> <p>I Invalid (high-impedance)</p> <p>L Low</p>	<p>P Period</p> <p>R Rise</p> <p>V Valid</p> <p>Z High-impedance</p>
---	--

3.2.2 TIMING CONDITIONS

The operating temperature and voltage specified in [Table 3-3](#) apply to all timing specifications unless otherwise noted. [Figure 3-2](#) specifies the load conditions for the timing specifications.

TABLE 3-3: TEMPERATURE AND VOLTAGE SPECIFICATIONS - AC

AC CHARACTERISTICS	<p>Standard Operating Conditions (unless otherwise stated)</p> <p>Operating temperature $-40^{\circ}\text{C} \leq T_A \leq +85^{\circ}\text{C}$</p> <p>Operating voltage VDD range as described in DC spec, Section 3.1 "DC Characteristics".</p>
---------------------------	---

FIGURE 3-2: LOAD CONDITIONS FOR DEVICE TIMING SPECIFICATIONS

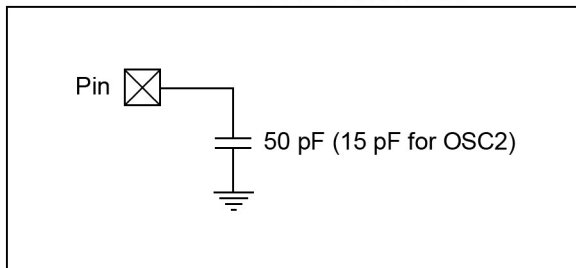

MCP2200

3.2.3 TIMING DIAGRAMS AND SPECIFICATIONS

TABLE 3-4: RESET, OSCILLATOR START-UP TIMER AND POWER-UP TIMER PARAMETERS

Standard Operating Conditions (unless otherwise stated)							
Operating Temperature $-40^{\circ}\text{C} \leq T_A \leq +85^{\circ}\text{C}$							
Param No.	Sym	Characteristic	Min	Typ [†]	Max	Units	Conditions
30	TRST	$\overline{\text{MCLR}}$ Pulse Width (low)	2	—	—	μs	
31	TPWRT	Power-up timer	40	65	140	ms	
32	TOST	Oscillator startup time	—	1024	—	TOST	

* These parameters are characterized but not tested.

† Data in "Typ" column is at 5V, 25°C unless otherwise stated. These parameters are for design guidance only and are not tested.

4.0 PACKAGING INFORMATION

4.1 Package Marking Information

20-Lead QFN



Example

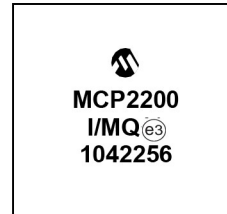

20-Lead SOIC

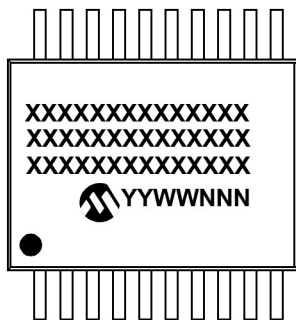

Example:

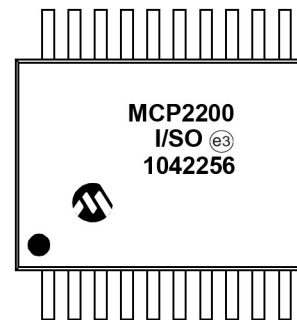

20-Lead SSOP

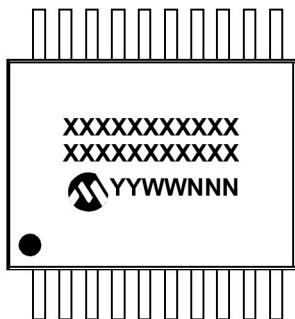

Example:

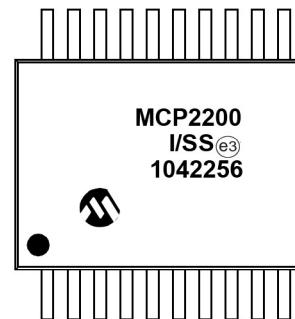

Legend:	XX...X	Customer-specific information
	Y	Year code (last digit of calendar year)
	YY	Year code (last 2 digits of calendar year)
	WW	Week code (week of January 1 is week '01')
	NNN	Alphanumeric traceability code
	e3	Pb-free JEDEC designator for Matte Tin (Sn)
	*	This package is Pb-free. The Pb-free JEDEC designator (e3) can be found on the outer packaging for this package.

Note: In the event the full Microchip part number cannot be marked on one line, it will be carried over to the next line, thus limiting the number of available characters for customer-specific information.

MCP2200

20-Lead Plastic Quad Flat, No Lead Package (MQ) – 5x5x0.9 mm Body [QFN]

Note: For the most current package drawings, please see the Microchip Packaging Specification located at <http://www.microchip.com/packaging>

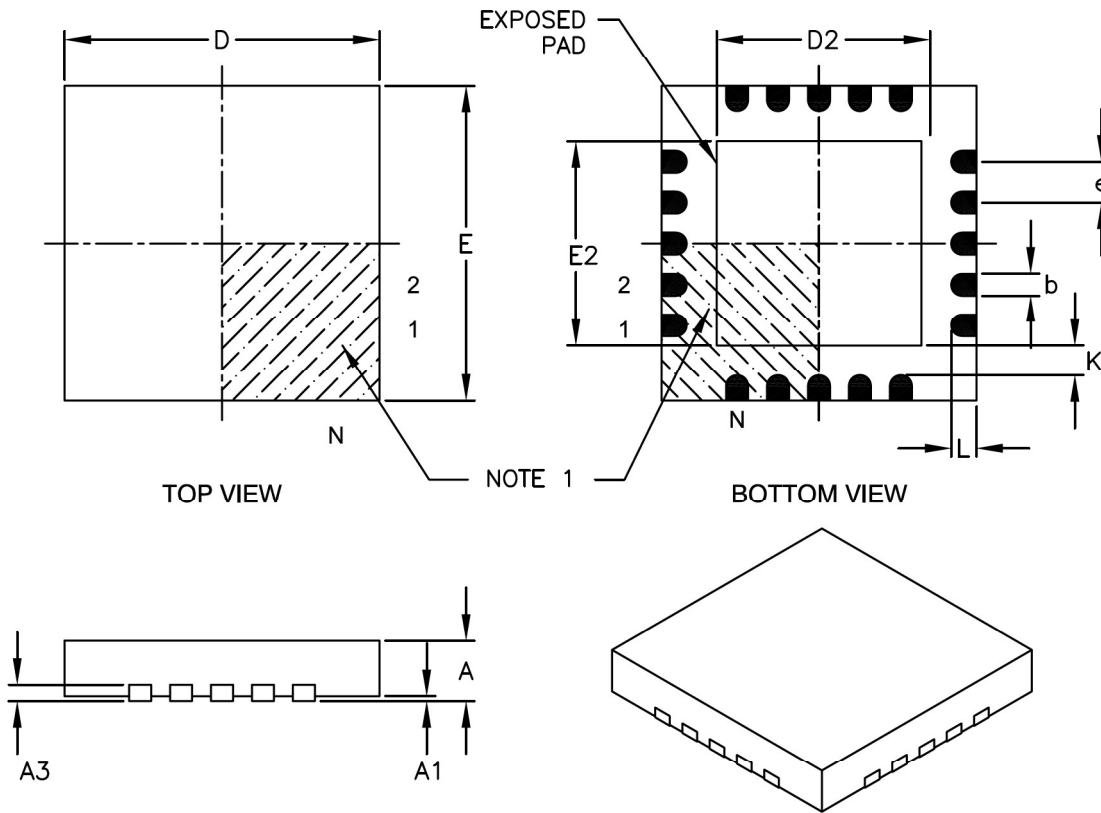

Dimension Limits	Units	MILLIMETERS		
		MIN	NOM	MAX
Number of Pins	N	20		
Pitch	e	0.65 BSC		
Overall Height	A	0.80	0.90	1.00
Standoff	A1	0.00	0.02	0.05
Contact Thickness	A3	0.20 REF		
Overall Width	E	5.00 BSC		
Exposed Pad Width	E2	3.15	3.25	3.35
Overall Length	D	5.00 BSC		
Exposed Pad Length	D2	3.15	3.25	3.35
Contact Width	b	0.25	0.30	0.35
Contact Length	L	0.35	0.40	0.45
Contact-to-Exposed Pad	K	0.20	-	-

Notes:

- Pin 1 visual index feature may vary, but must be located within the hatched area.
- Package is saw singulated.
- Dimensioning and tolerancing per ASME Y14.5M.

BSC: Basic Dimension. Theoretically exact value shown without tolerances.

REF: Reference Dimension, usually without tolerance, for information purposes only.

Microchip Technology Drawing C04-139B

20-Lead Plastic Quad Flat, No Lead Package (MQ) - 5x5 mm Body [QFN] With 0.40mm Contact Length

Note: For the most current package drawings, please see the Microchip Packaging Specification located at <http://www.microchip.com/packaging>

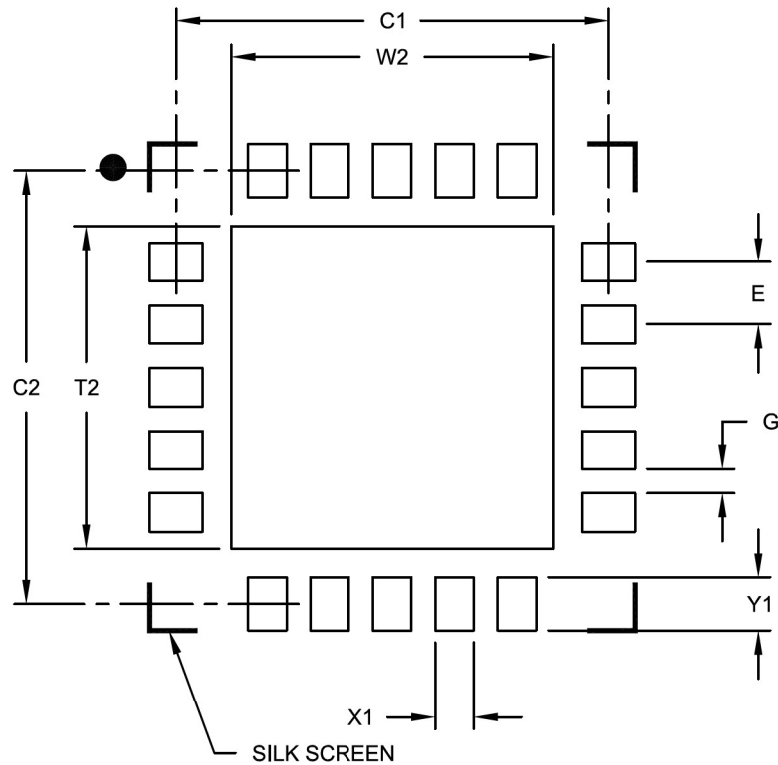

RECOMMENDED LAND PATTERN

Dimension Limits	Units	MILLIMETERS		
		MIN	NOM	MAX
Contact Pitch	E	0.65 BSC		
Optional Center Pad Width	W2			3.35
Optional Center Pad Length	T2			3.35
Contact Pad Spacing	C1		4.50	
Contact Pad Spacing	C2		4.50	
Contact Pad Width (X20)	X1			0.40
Contact Pad Length (X20)	Y1			0.55
Distance Between Pads	G	0.20		

Notes:

1. Dimensioning and tolerancing per ASME Y14.5M

BSC: Basic Dimension. Theoretically exact value shown without tolerances.

Microchip Technology Drawing No. C04-2139A

MCP2200

20-Lead Plastic Small Outline (SO) – Wide, 7.50 mm Body [SOIC]

Note: For the most current package drawings, please see the Microchip Packaging Specification located at <http://www.microchip.com/packaging>

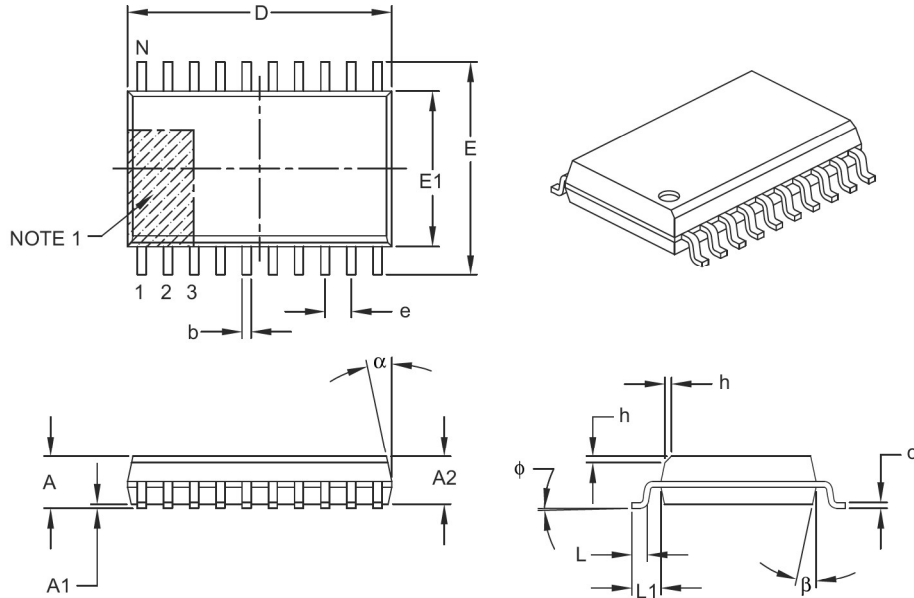

Dimension Limits	Units	MILLIMETERS		
		MIN	NOM	MAX
Number of Pins	N	20		
Pitch	e	1.27 BSC		
Overall Height	A	–	–	2.65
Molded Package Thickness	A2	2.05	–	–
Standoff §	A1	0.10	–	0.30
Overall Width	E	10.30 BSC		
Molded Package Width	E1	7.50 BSC		
Overall Length	D	12.80 BSC		
Chamfer (optional)	h	0.25	–	0.75
Foot Length	L	0.40	–	1.27
Footprint	L1	1.40 REF		
Foot Angle	ϕ	0°	–	8°
Lead Thickness	c	0.20	–	0.33
Lead Width	b	0.31	–	0.51
Mold Draft Angle Top	α	5°	–	15°
Mold Draft Angle Bottom	β	5°	–	15°

Notes:

- Pin 1 visual index feature may vary, but must be located within the hatched area.
- § Significant Characteristic.
- Dimensions D and E1 do not include mold flash or protrusions. Mold flash or protrusions shall not exceed 0.15 mm per side.
- Dimensioning and tolerancing per ASME Y14.5M.

BSC: Basic Dimension. Theoretically exact value shown without tolerances.

REF: Reference Dimension, usually without tolerance, for information purposes only.

Microchip Technology Drawing C04-094B

20-Lead Plastic Small Outline (SO) - Wide, 7.50 mm Body [SOIC]

Note: For the most current package drawings, please see the Microchip Packaging Specification located at <http://www.microchip.com/packaging>

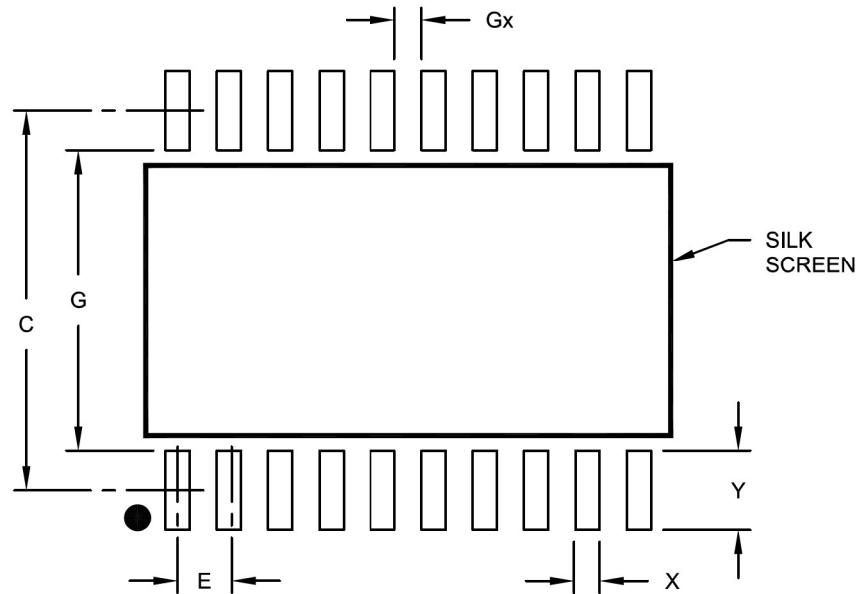

RECOMMENDED LAND PATTERN

Dimension Limits	Units	MILLIMETERS		
		MIN	NOM	MAX
Contact Pitch	E	1.27 BSC		
Contact Pad Spacing	C		9.40	
Contact Pad Width (X20)	X			0.60
Contact Pad Length (X20)	Y			1.95
Distance Between Pads	Gx	0.67		
Distance Between Pads	G	7.45		

Notes:

1. Dimensioning and tolerancing per ASME Y14.5M

BSC: Basic Dimension. Theoretically exact value shown without tolerances.

Microchip Technology Drawing No. C04-2094A

MCP2200

20-Lead Plastic Shrink Small Outline (SS) – 5.30 mm Body [SSOP]

Note: For the most current package drawings, please see the Microchip Packaging Specification located at <http://www.microchip.com/packaging>

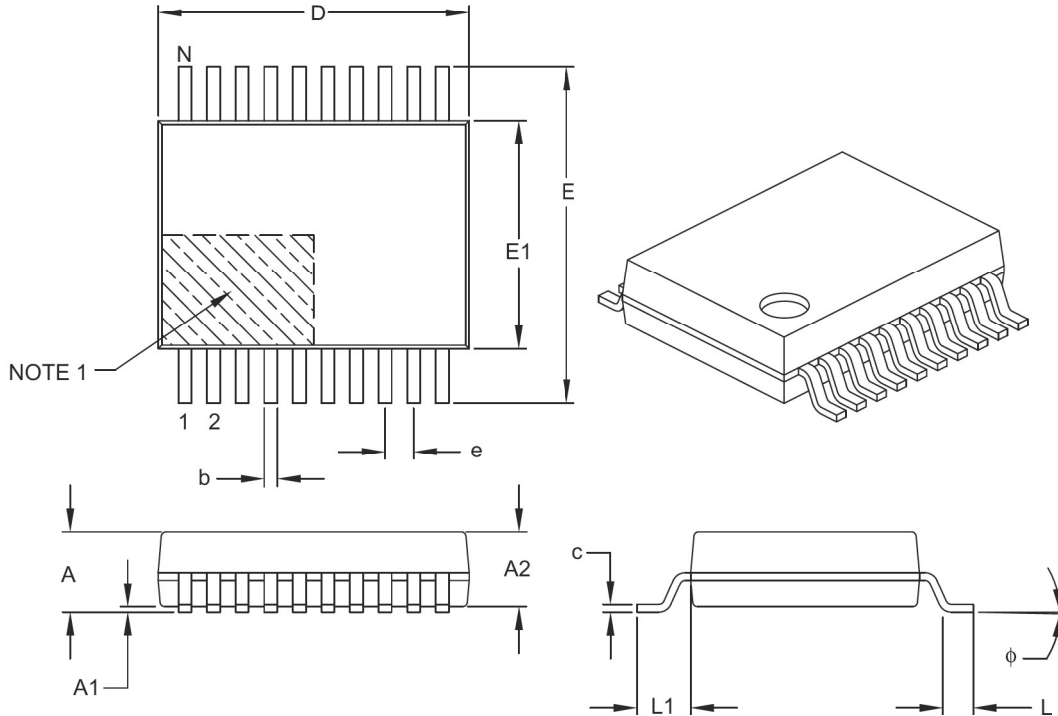

		Units	MILLIMETERS		
Dimension Limits			MIN	NOM	MAX
Number of Pins	N		20		
Pitch	e		0.65 BSC		
Overall Height	A		–	–	2.00
Molded Package Thickness	A2		1.65	1.75	1.85
Standoff	A1		0.05	–	–
Overall Width	E		7.40	7.80	8.20
Molded Package Width	E1		5.00	5.30	5.60
Overall Length	D		6.90	7.20	7.50
Foot Length	L		0.55	0.75	0.95
Footprint	L1		1.25 REF		
Lead Thickness	c		0.09	–	0.25
Foot Angle	ϕ		0°	4°	8°
Lead Width	b		0.22	–	0.38

Notes:

- Pin 1 visual index feature may vary, but must be located within the hatched area.
- Dimensions D and E1 do not include mold flash or protrusions. Mold flash or protrusions shall not exceed 0.20 mm per side.
- Dimensioning and tolerancing per ASME Y14.5M.

BSC: Basic Dimension. Theoretically exact value shown without tolerances.

REF: Reference Dimension, usually without tolerance, for information purposes only.

Microchip Technology Drawing C04-072B

20-Lead Plastic Shrink Small Outline (SS) - 5.30 mm Body [SSOP]

Note: For the most current package drawings, please see the Microchip Packaging Specification located at <http://www.microchip.com/packaging>

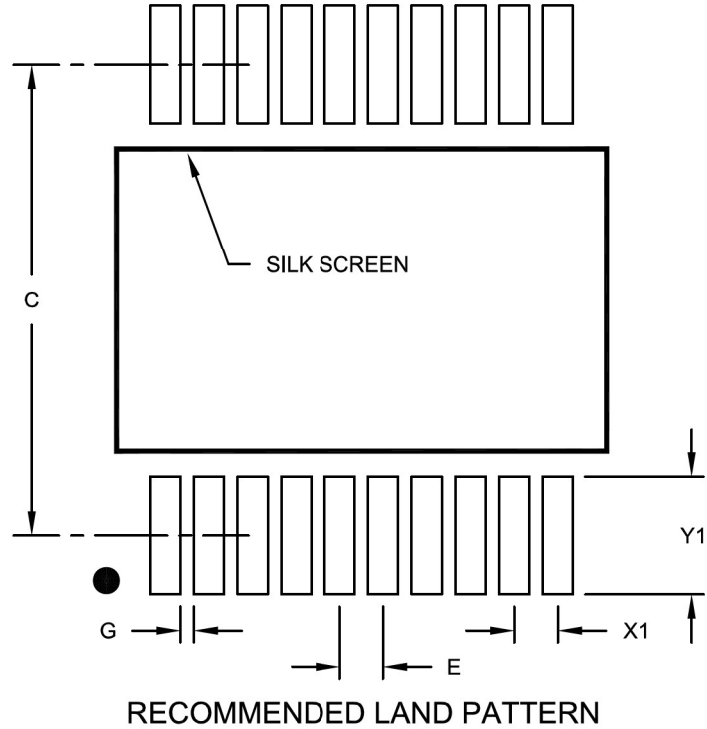

Dimension Limits	Units	MILLIMETERS		
		MIN	NOM	MAX
Contact Pitch	E	0.65 BSC		
Contact Pad Spacing	C		7.20	
Contact Pad Width (X20)	X1			0.45
Contact Pad Length (X20)	Y1			1.75
Distance Between Pads	G	0.20		

Notes:

1. Dimensioning and tolerancing per ASME Y14.5M

BSC: Basic Dimension. Theoretically exact value shown without tolerances.

Microchip Technology Drawing No. C04-2072A

MCP2200

NOTES:

APPENDIX A: REVISION HISTORY

Revision B (March 2011)

The following is the list of modifications:

1. Added new section [Section 1.5.2 “MCP2200 Power Options”](#).
2. Updated entire [Section 2.3 “Simple Configuration and I/O DLL”](#).
3. Added values to parameters TH01 and TH02 for the 20-Lead 5x5 QFN package in [Table 3-2](#).

Revision A (March 2010)

Original Release of this Document.

MCP2200

NOTES:

PRODUCT IDENTIFICATION SYSTEM

To order or obtain information, e.g., on pricing or delivery, contact your local Microchip sales office.

<u>PART NO.</u>	<u>X</u>	<u>/XX</u>	
Device	Temperature Range	Package	
Device	MCP2200: USB-to-UART serial converter MCP2200T: USB-to-UART serial converter (Tape and Reel)		
Temperature Range	I = -40°C to +85°C (Industrial)		
Package	MQ = Plastic Quad Flat, No Lead Package 5x5x0.9 mm Body (QFN), 20-Lead SO = Plastic Small Outline - Wide, 7.50 mm Body (SO), 20-Lead SS = Plastic Shrink Small Outline - 5.30 mm Body (SS) 20-Lead		

Examples:

- a) MCP2200- I/MQ: Industrial temperature, 20LD QFN Package.
- b) MCP2200T- I/MQ: Tape and Reel, Industrial temperature, 20LD QFN Package.
- a) MCP2200- I/SO: Industrial temperature, 20LD SOIC Package.
- b) MCP2200T- I/SO: Tape and Reel, Industrial temperature, 20LD SOIC Package.
- a) MCP2200- I/SS: Industrial temperature, 20LD SSOP Package.
- b) MCP2200T- I/SS: Tape and Reel, Industrial temperature, 20LD SSOP Package.

MCP2200

NOTES:

Note the following details of the code protection feature on Microchip devices:

- Microchip products meet the specification contained in their particular Microchip Data Sheet.
- Microchip believes that its family of products is one of the most secure families of its kind on the market today, when used in the intended manner and under normal conditions.
- There are dishonest and possibly illegal methods used to breach the code protection feature. All of these methods, to our knowledge, require using the Microchip products in a manner outside the operating specifications contained in Microchip's Data Sheets. Most likely, the person doing so is engaged in theft of intellectual property.
- Microchip is willing to work with the customer who is concerned about the integrity of their code.
- Neither Microchip nor any other semiconductor manufacturer can guarantee the security of their code. Code protection does not mean that we are guaranteeing the product as “unbreakable.”

Code protection is constantly evolving. We at Microchip are committed to continuously improving the code protection features of our products. Attempts to break Microchip's code protection feature may be a violation of the Digital Millennium Copyright Act. If such acts allow unauthorized access to your software or other copyrighted work, you may have a right to sue for relief under that Act.

Information contained in this publication regarding device applications and the like is provided only for your convenience and may be superseded by updates. It is your responsibility to ensure that your application meets with your specifications. MICROCHIP MAKES NO REPRESENTATIONS OR WARRANTIES OF ANY KIND WHETHER EXPRESS OR IMPLIED, WRITTEN OR ORAL, STATUTORY OR OTHERWISE, RELATED TO THE INFORMATION, INCLUDING BUT NOT LIMITED TO ITS CONDITION, QUALITY, PERFORMANCE, MERCHANTABILITY OR FITNESS FOR PURPOSE. Microchip disclaims all liability arising from this information and its use. Use of Microchip devices in life support and/or safety applications is entirely at the buyer's risk, and the buyer agrees to defend, indemnify and hold harmless Microchip from any and all damages, claims, suits, or expenses resulting from such use. No licenses are conveyed, implicitly or otherwise, under any Microchip intellectual property rights.

Trademarks

The Microchip name and logo, the Microchip logo, dsPIC, KEELOQ, KEELOQ logo, MPLAB, PIC, PICmicro, PICSTART, PIC³² logo, rPIC and UNI/O are registered trademarks of Microchip Technology Incorporated in the U.S.A. and other countries.

FilterLab, Hampshire, HI-TECH C, Linear Active Thermistor, MXDEV, MXLAB, SEEVAL and The Embedded Control Solutions Company are registered trademarks of Microchip Technology Incorporated in the U.S.A.

Analog-for-the-Digital Age, Application Maestro, CodeGuard, dsPICDEM, dsPICDEM.net, dsPICworks, dsSPEAK, ECAN, ECONOMONITOR, FanSense, HI-TIDE, In-Circuit Serial Programming, ICSP, Mindi, MiWi, MPASM, MPLAB Certified logo, MPLIB, MPLINK, mTouch, Omniscient Code Generation, PICC, PICC-18, PICDEM, PICDEM.net, PICkit, PICTail, REAL ICE, rLAB, Select Mode, Total Endurance, TSHARC, UniWinDriver, WiperLock and ZENA are trademarks of Microchip Technology Incorporated in the U.S.A. and other countries.

SQTP is a service mark of Microchip Technology Incorporated in the U.S.A.

All other trademarks mentioned herein are property of their respective companies.

© 2011, Microchip Technology Incorporated, Printed in the U.S.A., All Rights Reserved.

 Printed on recycled paper.

ISBN: 978-1-60932-841-2

Microchip received ISO/TS-16949:2002 certification for its worldwide headquarters, design and wafer fabrication facilities in Chandler and Tempe, Arizona; Gresham, Oregon and design centers in California and India. The Company's quality system processes and procedures are for its PIC® MCUs and dsPIC® DSCs, KEELOQ® code hopping devices, Serial EEPROMs, microperipherals, nonvolatile memory and analog products. In addition, Microchip's quality system for the design and manufacture of development systems is ISO 9001:2000 certified.

**QUALITY MANAGEMENT SYSTEM
CERTIFIED BY DNV
== ISO/TS 16949:2002 ==**



MICROCHIP

Worldwide Sales and Service

AMERICAS

Corporate Office
2355 West Chandler Blvd.
Chandler, AZ 85224-6199
Tel: 480-792-7200
Fax: 480-792-7277
Technical Support:
<http://support.microchip.com>
Web Address:
www.microchip.com

Atlanta
Duluth, GA
Tel: 678-957-9614
Fax: 678-957-1455

Boston
Westborough, MA
Tel: 774-760-0087
Fax: 774-760-0088

Chicago
Itasca, IL
Tel: 630-285-0071
Fax: 630-285-0075

Cleveland
Independence, OH
Tel: 216-447-0464
Fax: 216-447-0643

Dallas
Addison, TX
Tel: 972-818-7423
Fax: 972-818-2924

Detroit
Farmington Hills, MI
Tel: 248-538-2250
Fax: 248-538-2260

Kokomo
Kokomo, IN
Tel: 765-864-8360
Fax: 765-864-8387

Los Angeles
Mission Viejo, CA
Tel: 949-462-9523
Fax: 949-462-9608

Santa Clara
Santa Clara, CA
Tel: 408-961-6444
Fax: 408-961-6445

Toronto
Mississauga, Ontario,
Canada
Tel: 905-673-0699
Fax: 905-673-6509

ASIA/PACIFIC

Asia Pacific Office
Suites 3707-14, 37th Floor
Tower 6, The Gateway
Harbour City, Kowloon
Hong Kong
Tel: 852-2401-1200
Fax: 852-2401-3431

Australia - Sydney
Tel: 61-2-9868-6733
Fax: 61-2-9868-6755

China - Beijing
Tel: 86-10-8528-2100
Fax: 86-10-8528-2104

China - Chengdu
Tel: 86-28-8665-5511
Fax: 86-28-8665-7889

China - Chongqing
Tel: 86-23-8980-9588
Fax: 86-23-8980-9500

China - Hong Kong SAR
Tel: 852-2401-1200
Fax: 852-2401-3431

China - Nanjing
Tel: 86-25-8473-2460
Fax: 86-25-8473-2470

China - Qingdao
Tel: 86-532-8502-7355
Fax: 86-532-8502-7205

China - Shanghai
Tel: 86-21-5407-5533
Fax: 86-21-5407-5066

China - Shenyang
Tel: 86-24-2334-2829
Fax: 86-24-2334-2393

China - Shenzhen
Tel: 86-755-8203-2660
Fax: 86-755-8203-1760

China - Wuhan
Tel: 86-27-5980-5300
Fax: 86-27-5980-5118

China - Xian
Tel: 86-29-8833-7252
Fax: 86-29-8833-7256

China - Xiamen
Tel: 86-592-2388138
Fax: 86-592-2388130

China - Zhuhai
Tel: 86-756-3210040
Fax: 86-756-3210049

ASIA/PACIFIC

India - Bangalore
Tel: 91-80-3090-4444
Fax: 91-80-3090-4123

India - New Delhi
Tel: 91-11-4160-8631
Fax: 91-11-4160-8632

India - Pune
Tel: 91-20-2566-1512
Fax: 91-20-2566-1513

Japan - Yokohama
Tel: 81-45-471- 6166
Fax: 81-45-471-6122

Korea - Daegu
Tel: 82-53-744-4301
Fax: 82-53-744-4302

Korea - Seoul
Tel: 82-2-554-7200
Fax: 82-2-558-5932 or
82-2-558-5934

Malaysia - Kuala Lumpur
Tel: 60-3-6201-9857
Fax: 60-3-6201-9859

Malaysia - Penang
Tel: 60-4-227-8870
Fax: 60-4-227-4068

Philippines - Manila
Tel: 63-2-634-9065
Fax: 63-2-634-9069

Singapore
Tel: 65-6334-8870
Fax: 65-6334-8850

Taiwan - Hsin Chu
Tel: 886-3-6578-300
Fax: 886-3-6578-370

Taiwan - Kaohsiung
Tel: 886-7-213-7830
Fax: 886-7-330-9305

Taiwan - Taipei
Tel: 886-2-2500-6610
Fax: 886-2-2508-0102

Thailand - Bangkok
Tel: 66-2-694-1351
Fax: 66-2-694-1350

EUROPE

Austria - Wels
Tel: 43-7242-2244-39
Fax: 43-7242-2244-393

Denmark - Copenhagen
Tel: 45-4450-2828
Fax: 45-4485-2829

France - Paris
Tel: 33-1-69-53-63-20
Fax: 33-1-69-30-90-79

Germany - Munich
Tel: 49-89-627-144-0
Fax: 49-89-627-144-44

Italy - Milan
Tel: 39-0331-742611
Fax: 39-0331-466781

Netherlands - Drunen
Tel: 31-416-690399
Fax: 31-416-690340

Spain - Madrid
Tel: 34-91-708-08-90
Fax: 34-91-708-08-91

UK - Wokingham
Tel: 44-118-921-5869
Fax: 44-118-921-5820

08/04/10