1-Port PSE PoE Controller Datasheet

Introduction

Microchip's PD69101 device is a single-port, mixed-signal, and high-voltage Power over Ethernet (PoE) driver. It is utilized in Ethernet switches and enables the network devices to share power and data over the same cable. It enables detection of IEEE® 802.3af-2003 compliant powered devices (PDs) and IEEE 802.3at high-power devices, ensuring safe power feeding and disconnection of ports, with full digital control and a minimum of external components. A plug-and-play device, the PD69101 executes all real-time functions as specified in the IEEE 802.3af-2003 (AF) and IEEE 802.3at high-power (AT) standards, including load detection, AF and AT classification, and multiple classification attempts (MCA).

Integrating power, analog, and state-of-the-art logic, the PD69101 fits into a single 24-pin plastic QFN package. The chip includes built-in internal thermal protection, and two LEDs provide port state and port type (AF/AT) indication.

PD69101 device offer the following important features.

- Designed to detect and disable disconnected ports, utilizing DC disconnection methods as specified in the AF and IEEE802.3 af/at standards.
- Low-power device using an internal 0.34Ω MOSFET and an external 0.5Ω sense resistor.
- Optionally detects legacy/pre-standard PD devices.
- Provides overload, underload, overvoltage, overtemperature, and short-circuiting PD protection.
- Supports supply voltages ranging from 32V to 57 VDC with no need for additional power supply sources.

Features

The PD69101 device has the following key features.

- Fully AF and AT compliant
- Includes two-event classification
- Supports pre-standard PD detection
- Single DC voltage input (32V–57 VDC)
- Supports 2-pairs
- V_{MAIN} out-of-range protection
- Wide temperature range: -40°C to 85°C
- Overtemperature protection
- Low thermal dissipation (0.5Ω sense resistor)
- Includes on/off command pin
- 2× direct LEDs drive
- Continuous port monitoring and system data
- Configurable load current setting
- Configurable AT/AF modes
- Configurable standard and legacy detection mode
- Power soft-start mechanism
- On-chip thermal protection
- Voltage monitoring and protection
- Built-in 3.3 VDC regulator
- Internal power-on-reset
- RoHS compliant
- Low R_{dson} FET: 0.3Ω
- MSL3

Typical 2-Pair Application

The following figure shows a typical application of simple plug-and-play PoE solution for a single Ethernet port switch or hub. POS and NEG signals must be connected to the switch RJ45 jack. AF and AT modes of operations are set through AF/AT and current-set pins (DGND or DVDD).

Figure 1. Typical 2-Pair Application

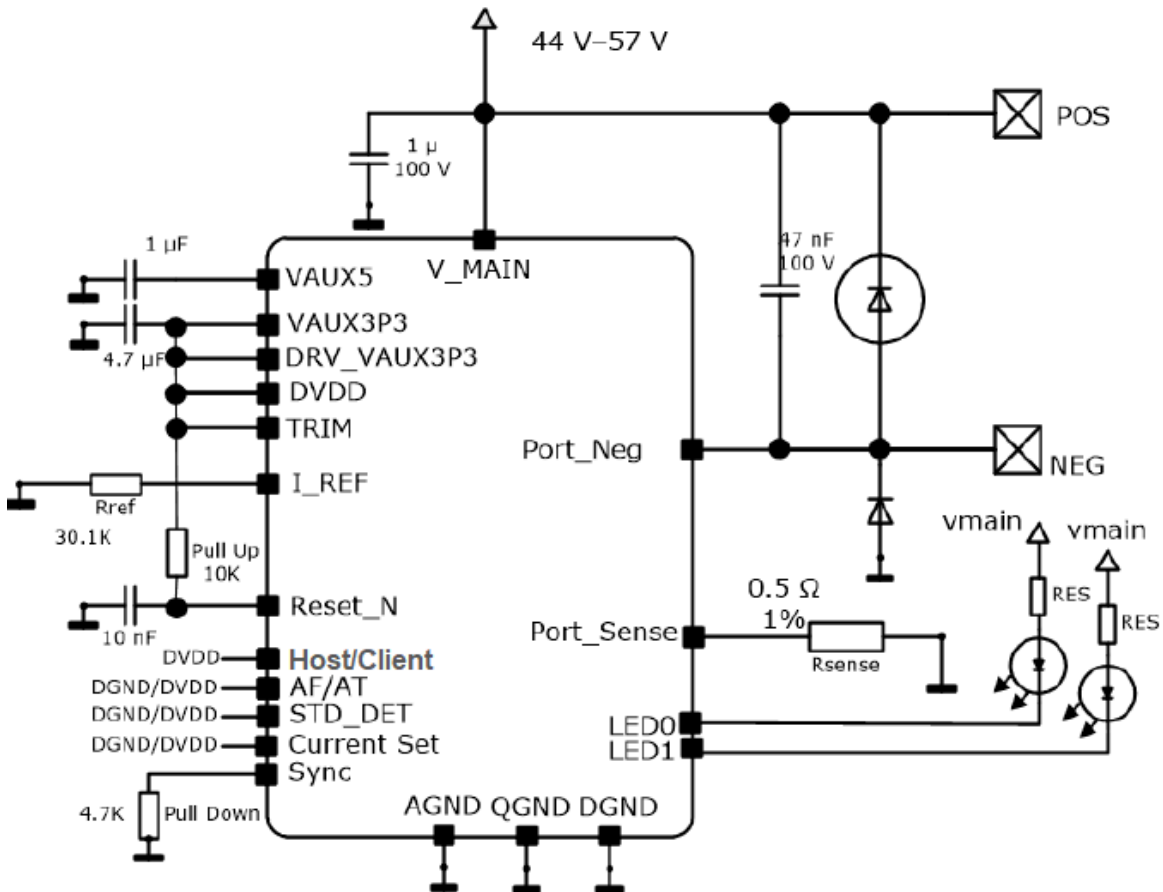

Table of Contents

Introduction.....	1
Features.....	2
Typical 2-Pair Application.....	3
1. Functional Description.....	5
1.1. Logic Main Control Module.....	5
1.2. Application Information.....	6
2. Electrical Specifications.....	11
2.1. Dynamic Characteristics.....	12
2.2. Absolute Maximum Ratings.....	13
2.3. Moisture Sensitivity.....	14
2.4. Power Dissipation Information.....	14
3. Pin Descriptions.....	15
3.1. CURRENT_SET and AF/AT.....	18
3.2. Mode of Operation Coding.....	18
3.3. LED I/Os Behavior.....	18
4. Package Specifications.....	20
4.1. RoHS and Solder Reflow Information.....	21
4.2. Thermal Specifications.....	22
4.3. Tape and Reel—Packaging Information.....	22
5. Ordering Information.....	24
6. Revision History.....	25
The Microchip Website.....	27
Product Change Notification Service.....	27
Customer Support.....	27
Microchip Devices Code Protection Feature.....	27
Legal Notice.....	27
Trademarks.....	28
Quality Management System.....	29
Worldwide Sales and Service.....	30

1. Functional Description

The PD69101 device has two sections, listed as follows:

- A digital section that controls and monitors the logical PoE functions (state machines, timings, and so on)
- An analog section that performs the front-end analog PoE functionality

The following figure shows the internal functional blocks of the PD69101 device.

Figure 1-1. PD69101 Internal Block Diagram

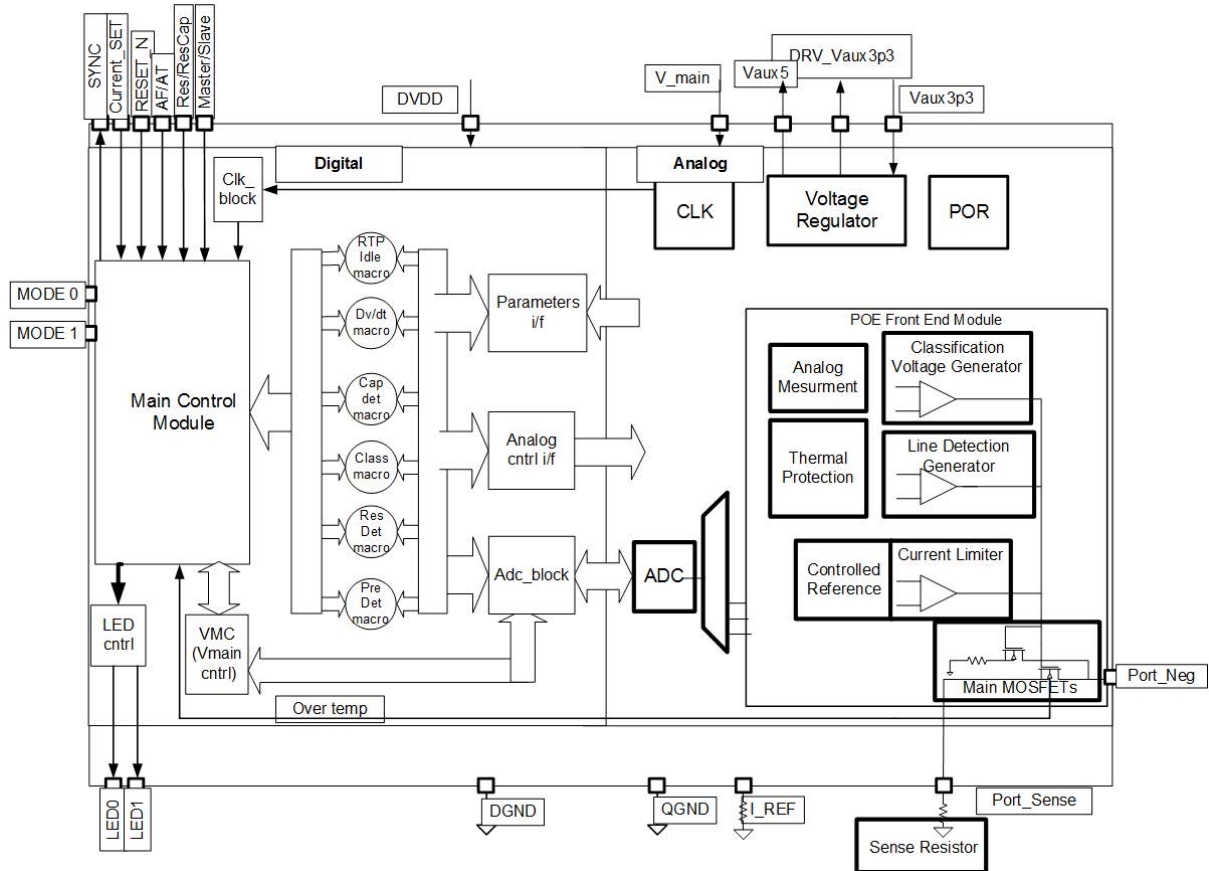

1.1 Logic Main Control Module

The logic main control block includes the following digital timing mechanisms and state machines, synchronizing, and activating the PoE functions.

- Real-Time Protection (RTP)
- Start-up macro (DVDT)
- Load signature detection (RES DET)
- Classification macro (CLASS)
- Voltage and current monitoring registers (VMC)
- LEDs stream out control indications
- ADC interfacing
- Direct digital signals with analog block

1.1.1 Line Detection Generator

Upon request from the main control module, four different voltage levels are generated by the line detection generator, ensuring robust AF/AT line detection functionality.

1.1.2 Classification Generator

Upon request from the main control module, the state machine applies a regulated class event and mark event voltage to the ports, as required by the IEEE standard.

1.1.3 Current Limiter

This circuit continuously monitors the current of powered ports and limits the current to a specific value, according to the pre-defined limits set by AF/AT and current_set pins. In cases where the current exceeds this specific level, the system starts measuring the elapsed time. If this time period is greater than a preset threshold, the port is disconnected.

1.1.4 Main MOSFET

Main power switching FET, used to control PoE current into the load.

1.1.5 Analog-to-Digital Converter (ADC)

A 10-bit analog-to-digital converter, used to convert analog signals into digital registers for the logic control module.

1.1.6 Power-on Reset (POR)

This circuit monitors the internal 3.3 VDC levels. If this voltage drops below specific thresholds, a reset signal is generated and the PD69101s are reset.

1.1.7 Voltage Regulator

The voltage regulator generates 3.3 VDC and 5 VDC for the internal circuitry. These voltages are derived from the V_{MAIN} supply.

1.1.8 CLK

CLK is an internal 8 MHz clock oscillator.

1.2 Application Information

The PD69101 performs IEEE 802.3af and IEEE 802.3at functionality as well as legacy (capacitor) and Cisco PD detection, in addition to protections such as short circuit and dV/dT protection upon startup.

1.2.1 Line Detection

The line detection feature detects a valid AF or AT load, as specified in the AF/AT standard. The resistor value should range from 19 K Ω to 26.5 K Ω . Line detection is based on four different voltage levels generated over the PD (the load), as shown in the following figure.

Figure 1-2. Typical PoE Voltage Timing Diagram

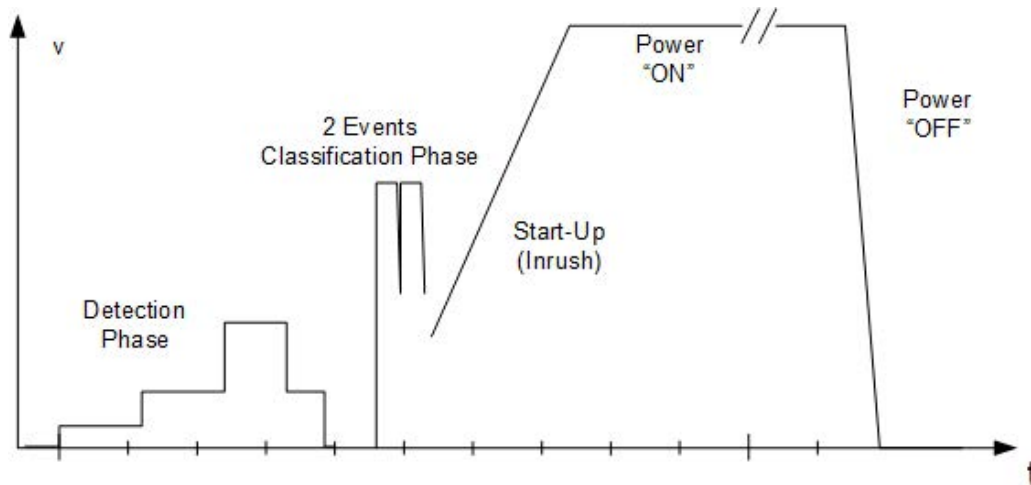

1.2.2 Legacy (Capacitor) Detection

In cases where pin 24 is set to 0, the PD69101's detection mechanism is configured to detect and power-up legacy PDs, as well as AF/AT compliant. This mechanism also detects and powers up Cisco legacy PDs.

1.2.3 Classification

The classification process takes place right after the resistor detection, is successfully completed. The main goal of the classification process is to detect the PD class, as specified in the IEEE802.3af and IEEE 802.3at standards. In IEEE 802.3af mode, the classification mechanism is based on a single voltage level (single class event). In IEEE 802.3at mode, the classification mechanism is based on two voltage levels (dual class event) as defined in IEEE 802.3at 2009. In IEEE 802.3at mode, when the PD is class 0–3, the PD69101 generates a single class event. When the PD is class 4, the PD69101 generates two class events.

1.2.4 Port Start Up

Upon a successful detection and classification process, power is applied to the load through a controlled start-up mechanism. During this period, current is limited to 425 mA for a typical duration of 65 mS, which enables the PD load to charge and enter a steady state power condition.

1.2.5 Over-Load Detection and Port Shut Down

After power-up, the PD69101 automatically initializes its internal protection mechanisms to monitor and disconnect power from the load in cases where extreme conditions (such as over-current or short port terminal scenarios) occur, as specified in the IEEE 802.3af/at standard.

1.2.6 Disconnect Detection

The PD69101 supports the DC disconnect function as per the IEEE 802.3af/at standard. This mechanism continuously monitors the load current and disconnects power in cases where the load current is below 7.5 mA (typical) for more than 322 mS.

1.2.7 Overtemperature Protection

The PD69101 has internal temperature sensors that continuously monitor junction temperature and disconnect load power when the junction temperature exceeds 200 °C. This mechanism protects the device from extreme events such as high ambient temperature or other thermo-mechanical failures that might damage the PD69101 device.

1.2.8 V_{MAIN} Out-of-Range Protection

The PD69101 automatically disconnects port power when V_{MAIN} exceeds 57.5 VDC \pm 0.5 VDC. This is an extremely valuable feature that protects the load, if the main power source is faulty or damaged.

1.2.9 Serial Communication: Monitoring Mode

When MODE0 and MODE1 input pins are configured to serial monitoring mode (01), the PD69101 continuously and repeatedly transmits out the content of nine internal registers.

- Data out stream is transmitted through LED1 (pin 14)
- Clock out stream is transmitted through LED0 (pin 13)
- Data stream is shifted out with a 1 MHz clock (1 μ sec)
- Total transaction packet length is 116 μ sec
- The transmission is repeated every 1 msec
- Between transactions, the clock is held low while the data stream out is stable high/low.

Note: To exploit LED1 and LED0 to communicate and monitor transmissions, use a 1 K Ω pull-up resistor to the DVDD.

The following table lists the stream out data transmits of 116 bits, starting from MSB to LSB.

Table 1-1. Serial Monitoring Mode

MSB								LSB
Internal 0	Internal 1	Internal 2	Internal 3	Internal 4	VPORT	VMAIN	IPOINT	Port Status
13 bits	10 bits	23 bits	16 bits	16 bits	10 bits	10 bits	13 bits	5 bits
78 internal signals used for internal tests					Port voltage measurement LSB= 58 mV V= Decimal \times 58 mV	VMAIN voltage measurement LSB= 58 mV V= Decimal \times 58 mV	Port current measurement LSB= 238 μ A I= Decimal \times 238 μ A	Real-time port status indication. For more information, see Table 1-2.

The following table lists the port status coding.

Table 1-2. Port Status Coding

Binary MSB to LSB	Decimal Value	Description
00000	0	PoE idle state
00001	1	
00010	2	
00011	3	Searching phase
00100	4	Res detection phase
00101	5	Back OFF phase
00110	6	Class phase
00111	7	
01000	8	
01001	9	Wait for start-up
01010	10	
01100	11	
01011	12	Cap detection
01101	13	Start-up
01110	14	
01111	15	
10000	16	Ongoing
10001	17	
10010	18	
10011	19	UDL
10010	18	Overload or short circuit
10011	19	VMAIN out of range
10100	20	

The following figure shows the data stream out.

Figure 1-3. Data Stream Out

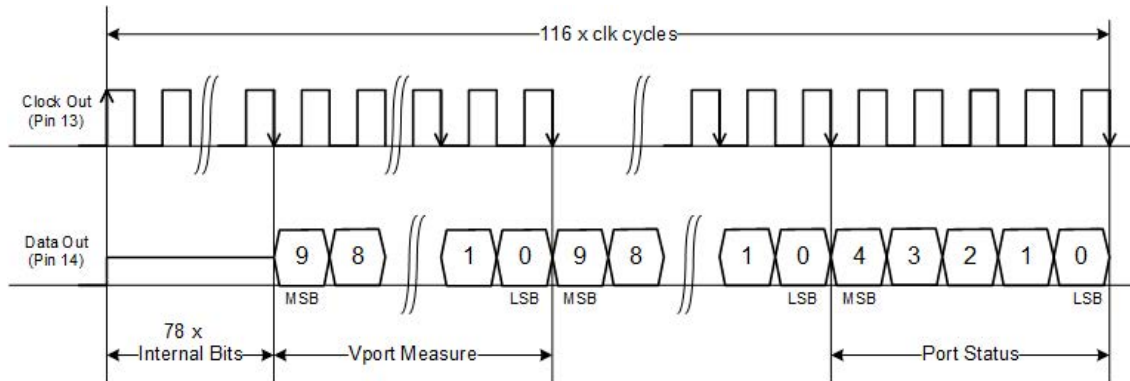

The following figure shows the multi-packet idle time between packets.

Figure 1-4. Multi-Packet Idle Time (Between Packets)

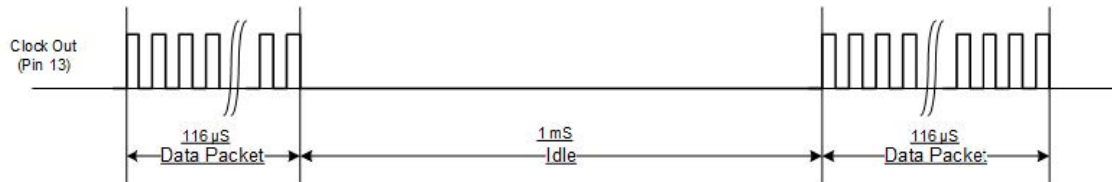

The following figure shows the data/clock typical timing.

Figure 1-5. Data/Clock Typical Timing

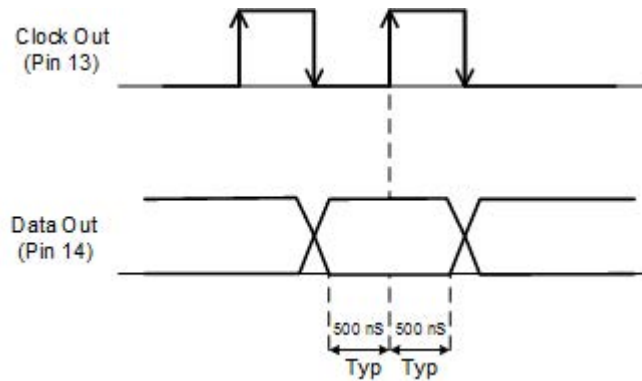

2. Electrical Specifications

Unless otherwise specified, the following specifications apply to the operating ambient temperature (T_{AMB}): $-40\text{ }^{\circ}\text{C}$ to $85\text{ }^{\circ}\text{C}$.

Table 2-1. Power Supply

Parameter	Symbol	Test Conditions/Comment	Minimum	Typical	Maximum	Unit
Input voltage	V_{MAIN}	Supports full IEEE 802.3 functionality	32	55	57	VDC
Power supply current at operating mode	—	$V_{MAIN} = 55\text{ V}$	—	—	10	mA

Table 2-2. Digital I/O

Parameter	Symbol	Test Conditions/Comment	Minimum	Typical	Maximum	Unit
Input logic, high threshold	V_{IH}	—	2.2	—	—	VDC
Input logic, low threshold	V_{IL}	—	—	—	0.8	VDC
Input hysteresis voltage	—	—	0.4	0.6	0.8	VDC
Input high current	I_{IH}	—	-10	—	10	μA
Input low current	I_{IL}	—	-10	—	10	μA
Output high voltage	V_{OH}	For $I_{OH} = -1\text{ mA}$	2.4	—	—	VDC
Output low voltage	V_{OL}	$I_{OH} = 1\text{ mA}$	—	—	0.4	VDC

Table 2-3. PoE Load Currents

Parameter	Symbol	Test Conditions/Comment	Minimum	Typical	Maximum	Unit
AT, high limit mode	AT_LIM_HIGH (high current level, for future use)	RSENSE = $0.5\ \Omega$ 1%, connected at Port_Sense pin	1.18	1.2	1.28	A
AT, medium limit mode	AT_LIM_MID (medium current level, for future use)		847	874	919	mA
AT, low limit mode	AT_LIM_LOW		706	722	767	mA
AF, limit mode	AF_LIM		410	425	448	mA

Table 2-4. Main Power Switching FET

Parameter	Symbol	Typical	Unit
On resistance	$R_{DS(on)}$	0.3	Ω
Internal thermal protection threshold	—	200	$^{\circ}\text{C}$

Table 2-5. LED0 and LED1 Drivers

Parameter	Symbol	Typical	Maximum	Unit
Current sink	I_{SINK} (from V_{MAIN} to AGND)	3	5	mA

2.1 Dynamic Characteristics

The PD69101 device utilizes three current level thresholds (I_{MIN} , I_{CUT} , and I_{LIM}) and three timers (T_{MIN} , T_{CUT} , and T_{LIM}).

- Loads that consume I_{LIM} current for more than T_{LIM} are labeled as **short circuit state** and shut down.
- Loads that dissipate more than I_{CUT} for longer than T_{CUT} are labeled as overloads and are shut down.
- If output power is below I_{MIN} for more than T_{MIN} , the PD is labeled as **no load** and is shut down.

Automatic recovery from overload and no load conditions is attempted every TOVLREC periods (typically one second). Output power is limited to I_{LIM} , which is a maximum peak current allowed at the port.

Table 2-6. IEEE 802.3 af Mode Parameters

Parameter	Symbol	Conditions	Minimum	Typical	Maximum	Unit
Automatic recovery from no load shutdown	—	T_{UDLREC} value, measured from port shutdown point (can be modified through control port)	—	1	—	sec
Cutoff timer accuracy	—	Typical accuracy of T_{cut}	—	2	—	ms
Inrush current	I_{Inrsh}	For $t = 50$ ms, $C_{load} = 180$ μ F (max)	400	—	450	mA
Output current operating range	I_{PORT}	Continuous operation after startup period	10	—	375	mA
Output power available operating range	P_{PORT}	Continuous operation after startup period, at port output	0.57	—	15.4	W
Off-mode current	I_{MIN1}	Must disconnect for T greater than T_{UVL}	0	—	5	mA
	I_{MIN1}	May or may not disconnect when T is greater than T_{UVL}	5	7.5	10	mA
PD power maintenance request drop-out time limit	T_{PMDO}	Buffer period to handle transitions	300	—	400	ms
Over-load current detection range	I_{CUT}	Time limited to T_{OVL}	350	—	400	mA
Over-load time limit	T_{OVL}	—	50	—	75	ms
Turn-on rise time	T_{RISE}	From 10% to 90% of V_{port} (specified for PD load consisting of 100 μ F capacitor in parallel to 200 Ω)	15	—	—	μ s
Turn-off time	T_{OFF}	From V_{PORT} to 2.8 VDC	—	—	500	ms
Time maintain power signature	T_{MPS}	DC modulation time for DC disconnect	—	49	—	ms

Table 2-7. IEEE 802.3at Mode Parameters

Parameter	Symbol	Conditions	Minimum	Typical	Maximum	Unit
Automatic recovery from no load shutdown	—	T_{UDLREC} value, measured from port shutdown point (can be modified through control port)	—	1	—	sec
Cutoff timer accuracy	—	Typical accuracy of T_{out}	—	2	—	ms
Inrush current	I_{Inrsh}	For $t = 50$ ms, $C_{load} = 180$ μ F (max)	400	—	450	mA
Output current operating range	I_{PORT}	Continuous operation after startup period	10	—	725	mA
Output power available operating range	P_{PORT}	Continuous operation after startup period, at port output	0.57	—	36.25	W
Off-mode current	I_{MIN1}	Must disconnect for T greater than T_{UVL}	0	—	5	mA
	I_{MIN2}	May or may not disconnect when T is greater than T_{UVL}	5	7.5	10	mA
PD power maintenance request drop-out time limit	T_{PMDO}	Buffer period to handle transitions	300	—	400	ms
Over-load current detection range	I_{CUT}	Time limited to T_{OVL}	—	—	600	mA
Over-load time limit	T_{OVL}	—	50	—	75	ms
Turn-on rise time	T_{RISE}	From 10% to 90% of V_{port} (specified for PD load consisting of 100 μ F capacitor in parallel to 200 Ω).	15	—	—	μ s
Turn-off time	T_{OFF}	From V_{PORT} to 2.8 VDC	—	—	500	ms
Time maintain power signature	T_{MPS}	DC modulation time for DC disconnect	—	49	—	ms

2.2 Absolute Maximum Ratings

The following table lists the absolute maximum ratings for the PD69101. Exceeding these ratings can cause damage to the device. Pin Port_Sense is ESD sensitive and passes 500V HBM. All voltages are with respect to ground. Currents are marked positive when flowing into a specified terminal and marked negative when flowing out of a specified terminal.

Table 2-8. Absolute Maximum Ratings

Parameter	Rating
Supply input voltage (V_{MAIN})	–0.3 VDC to 74 VDC
Port_Neg pin, LED0, LED1	–0.3 VDC to 74 VDC
Port_Sense pin	–0.3 VDC to 3.6 VDC
QGND, AGND pins	–0.3 VDC to 0.3 VDC
VAUX5	–0.3 V to 5.5V
All other pins	–0.3 VDC to 3.6 VDC
Operating ambient temperature range	–40 °C to 85 °C

.....continued

Parameter	Rating
Maximum operating junction temperature	150 °C
Storage temperature range	–65 °C to 150 °C
ESD protection at all I/O pins	±2 KV (HBM)

2.3 Moisture Sensitivity

This device is rated moisture sensitivity level 3 as specified in the joint IPC and JEDEC® standard IPC/JEDEC J-STD-020. For more information, see the *IPC and JEDEC standard*.

2.4 Power Dissipation Information

Table 2-9. Power Dissipation

Parameter	Value
Rsense power dissipation	$0.5 \Omega \times I_{PORT}^2$
Rds_ON power dissipation	$0.3 \Omega \times I_{PORT}^2$
Pport_AF = 15.4 W	PRsense = 51 mW (320 mA)
PRds_ON	31 mW (320 mA)
Pport_AT = 30 W	PRsense = 180 mW (600 mA)
PRds_ON	108 mW (600 mA)
Typical PD69101 self power dissipation (including internal regulations)	0.5W (50 VDC)
Typical PD69101 2-pairs AF application power dissipation	$0.5W + 51 \text{ mW} + 31 \text{ mW} = 0.582W$
Typical PD69101 2-pairs AT application power dissipation	$0.5W + 180 \text{ mW} + 108 \text{ mW} = 0.788W$

3. Pin Descriptions

The following figure shows the device pin diagram from the top and bottom views.

Figure 3-1. PD69101 Pinout

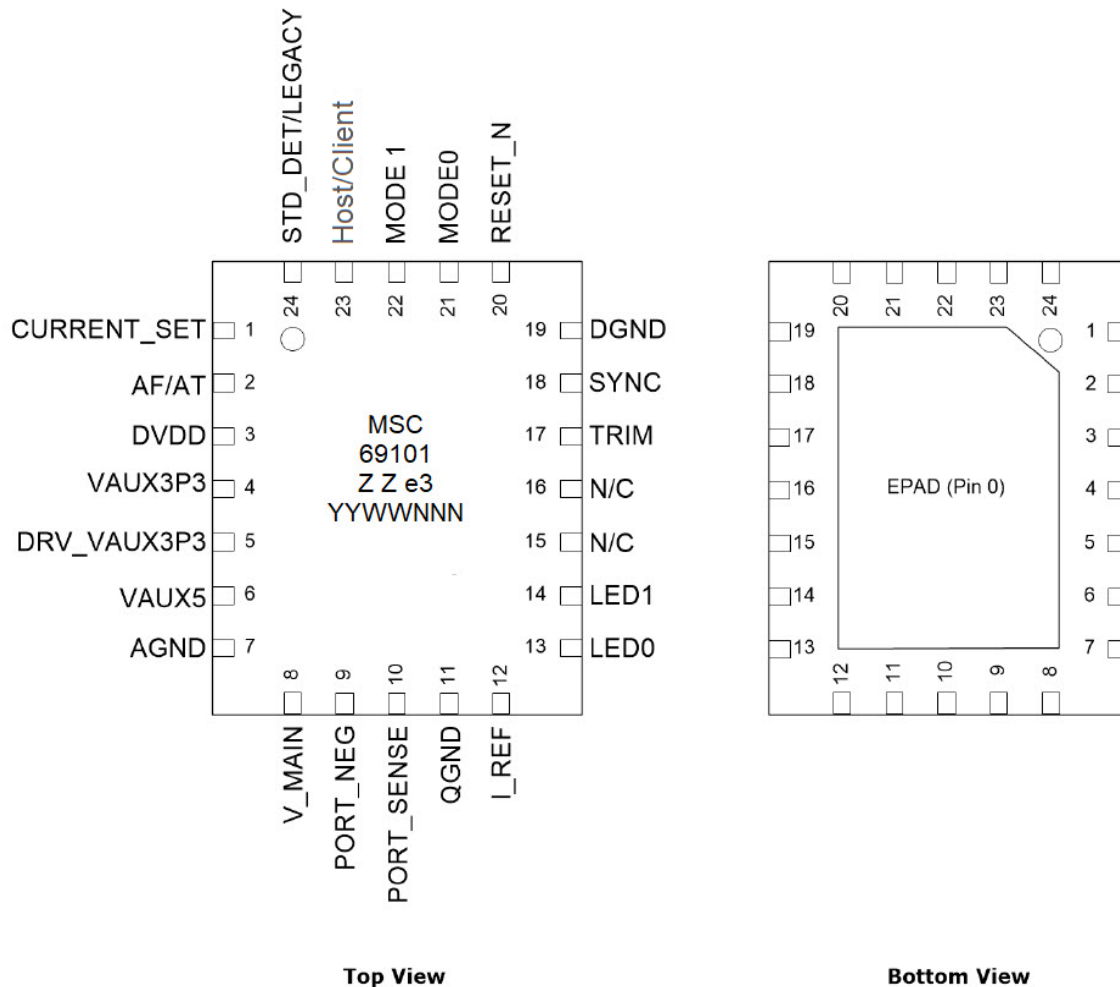

The following table lists the pin descriptions for the PD69101 device.

Table 3-1. Pin Descriptions

Number	Name	Type	Description
0	Exposed PAD	Analog ground	Exposed pad; metal plate on the IC bottom side connected to analog ground. A high-quality ground plane (about 500 mil. inch over 500 mil. inch) should be deployed around this pin whenever possible.

.....continued

Number	Name	Type	Description
1	CURRENT_SET	Digital input	User input to set AF/AT and maximum current limit.
2	AF/AT		Use pull-up resistors to DVDD or pull-down resistors to DGND to set the mode of operation as shown in Table 3-2 .
3	DVDD	Power in	Regulated input voltage (3.3V) for internal digital circuitry. Must be externally connected to pin 4.
4	VAUX3P3	Power in	Voltage regulation in 3.3 VDC. Connect to pin 5. A 4.7 μ F capacitor to AGND is recommended.
5	DRV_VAUX3P3	Power out	Internal voltage regulator out, 3.3 VDC. It must be externally connected to pin 4.
6	VAUX5	Power	Regulated 5 VDC voltage filter. A 1 μ F capacitor to AGND is recommended.
7	AGND	Power	Analog ground.
8	V_MAIN	Power	Supply voltage for the internal analog circuit. Place a low-ESR bypass capacitor with low impedance trace as close as possible to AGND and this pin (not less than 1 μ F).
9	PORT_NEG	Analog I/O	Negative output of the port.
10	PORT_SENSE	Analog input	Sense resistor port input (connected to 0.5, 1% Ω resistor to GND).
11	QGND	Power	Quiet analog ground; used for sensitive analog cells.
12	I_REF	Analog I/O	Resistor reference. Connect 30.1K 1% resistor to QGND.

.....continued

Number	Name	Type	Description
13	LED0	Open-drain I/O	Port status direct LED indications. For details, see Table 3-4 . This is a high-voltage, open-drain, active low (SINK) output pin. Connection to LED and V _{MAIN} through a ~18.2 K Ω (~3 mA) resistor is recommended.
14	LED1		
15	N/C	Analog I/O	Test pin (for production use only); keep open (not connected).
16	N/C		
17	TRIM	Analog input	Zapping input for IC production trimming. It must be connected to DVDD.
18	SYNC	Digital I/O	Synchronization open-drain I/O pin between host and client. In 2-pair mode (switch), this pin should be pulled down to DGND through a 4.7 K Ω resistor.
19	DGND	Digital I/O	Digital ground.
20	RESET_N	Digital input	Reset input/on-off command (active low).
21	MODE 0	Test I/O	Configuration input pins. Used to set mode of operation and test mode at production. Typically connected to DGND. For details, see Table 3-3 .
22	MODE 1		
23	Host/Client	Digital input	If connected to DVDD (3.3 VDC): host mode. If connected to GND: client mode.
24	STD_DET/LEGACY	Digital input	User input pin to set the chip mode of operation. 1: DVDD= IEEE 802.3af-compliant resistor detection only. 0: DGND= IEEE 802.3af/at detection and legacy (non-standard) line detection.

Note: 0= Connect to DGND and 1= connect to DVDD.

3.1 CURRENT_SET and AF/AT

The following table lists the pins that determine the typical PD load output current.

Table 3-2. CURRENT_SET and AF/AT Pins

AT/AF Pin	Current_Set Pin	Max. Current I _{CUT} [mA]	Typical I _{LIM} [mA]	IEEE 802.3
0	0	350	425	AF mode (standard)
1	0	600	722	AT mode (standard)
1	1	720	874	AT mode (high power)
0	1	1000	1200	AT mode (extra high power)

3.2 Mode of Operation Coding

The following table lists the mode of operation coding options related to pins 21 and 22.

Table 3-3. Configuration Coding

Mode 0	Mode 1	Mode	Description
0	0	Normal operation mode	Standard operation PoE mode. LED0 and LED1 outputs are used for direct LED drive as described in the following section.
0	1	Serial monitoring mode	Standard operation PoE mode. LED0 and LED1 are used to continuously stream out internal logic signals for PoE monitoring.
1	0	Test mode	Internal IC test mode; used in production only.
1	1	Test mode	Internal IC test mode; used in production only.

3.3 LED I/Os Behavior

The following tables list the LED I/Os behavior related to pins 13 and 14 in 2-pair application. In both application types, the LED pin is a high-voltage, open-drain, output pin, and an active low (sink) pin. That is, LED is “ON” when the I/O is pulled low.

Table 3-4. 2-Pair Behavior

Status Indications	LED0	LED1	Notes
AF mode—port ON	ON	OFF	Useful for bi-color LED connected from LED0 to LED1.

.....continued

Status Indications	LED0	LED1	Notes
AT mode (class AT was detected)—port ON	ON	ON	—
AF mode—over-load or short	Blink 1 Hz	OFF	Blinking continues for ~2 seconds.
AT mode—over-load or short	Blink 1 Hz	Blink 1 Hz	Blinking continues for ~2 seconds.
V _{MAIN} voltage is out of range or IC overtemperature	Blink 4 Hz	OFF	Blinking continues as long as overvoltage or overtemperature state exists.
AF mode—port OFF	OFF	ON	Useful for bi-color LED connected from LED0 to LED1.
AT mode—port OFF	OFF	OFF	—

4. Package Specifications

This section provides the package drawing, RoHS and solder reflow information, and thermal specifications for the PD69101 device.

The following figure shows PD69101 package is a 4 mm × 5 mm, 24-pin QFN.

Figure 4-1. QFN Package

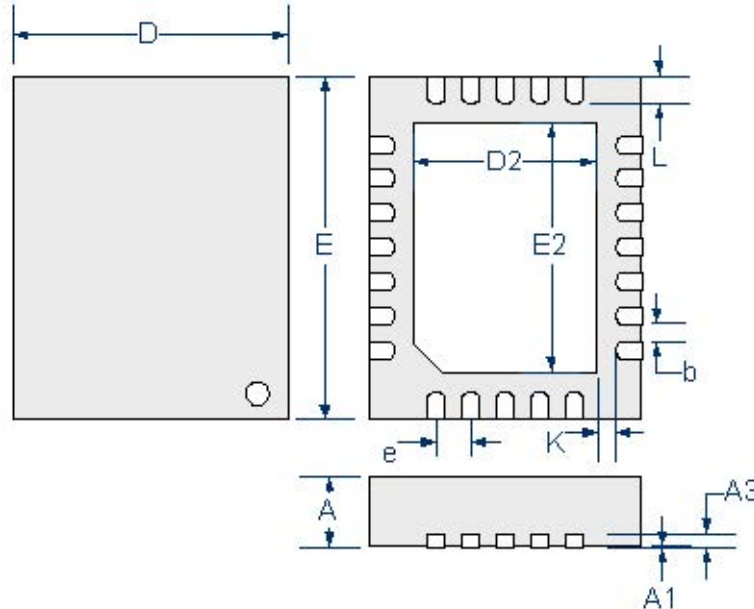

Dimensions do not include protrusions. It must not exceed 0.155 mm (0.006") on any side. Lead dimension must not include solder coverage.

The following table lists the dimensions for the QFN package.

Table 4-1. Package Dimensions

Dimension	Millimeters		Inches	
	Minimum	Maximum	Minimum	Maximum
A	0.80	1.00	0.031	0.039
A1	0.00	0.05	0	0.002
A3	0.20 REF		0.008 REF	
K	0.20 MIN		0.008 MIN	
e	0.50 BSC		0.02 BSC	
L	0.30	0.50	0.012	0.02
b	0.18	0.30	0.007	0.012
D2	2.50	2.75	0.098	0.108
E2	3.50	3.75	0.138	0.148
D	4.00 BSC		0.158 BSC	
E	5.00 BSC		0.197 BSC	

4.1 RoHS and Solder Reflow Information

The PD69101 device is rated RoHS 6/6. The package is lead (Pb)-free, with a 100% matte tin finish. The package peak temperature for solder reflow (40 seconds maximum exposure) is 260 °C (0 °C, -5 °C).

The following table lists the classification reflow profile information.

Table 4-2. Classification Reflow Profiles

Profile Feature	Pb-Free Assembly
Average ramp-up rate ($T_{S_{max}}$ to T_p)	3 °C/second max
Pre-heat:	150 °C
Temperature minimum ($T_{S_{min}}$)	200 °C
Temperature maximum ($T_{S_{max}}$)	60 seconds–180 seconds
Time ($T_{S_{min}}$ to $T_{S_{max}}$)	
Time maintained above:	217 °C
Temperature (T_L)	60 seconds–150 seconds
Time (t_L)	
Peak/classification temperature	See Figure 4-2
Time within 5 °C of actual peak temperature (t_p)	20 seconds–40 seconds
Ramp-down rate	6 °C/second max
Time 25 °C to peak temperature	8 minutes max

Note: All temperatures refer to the top-side of the package, measured on the package body surface.

The following illustration shows the classification reflow profile of the PD69101 device.

Figure 4-2. Classification Reflow Profile Diagram

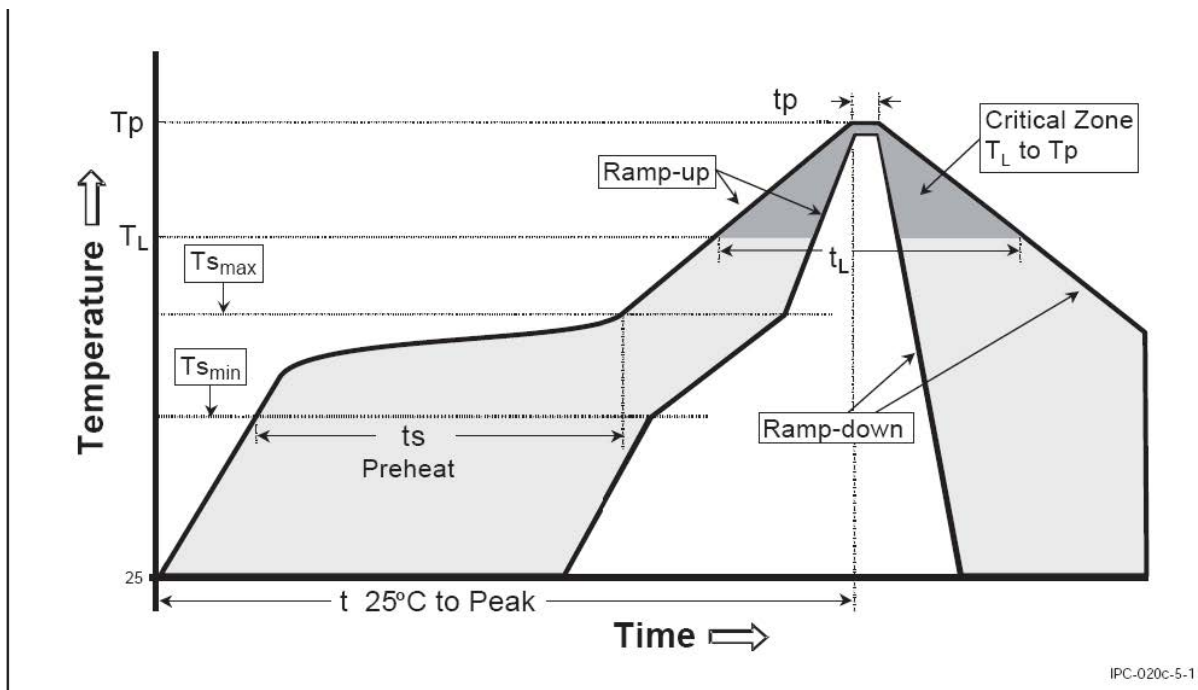

Note: Exceeding these ratings can damage the device.

4.2 Thermal Specifications

The following table lists the thermal specifications for the PD69101 device.

Table 4-3. Thermal Specifications

Parameter	Value
Typical thermal resistance: junction to ambient	25 °C/W
Typical thermal resistance: junction to case	4 °C/W
Typical thermal resistance: junction to board	2 °C/W

The θ_{JA} numbers are guidelines for the thermal performance of the device/pc-board system. All specifications assume no ambient airflow.

4.3 Tape and Reel—Packaging Information

The following section provides the tape and reel packaging information. The following figure shows the tape specification.

Figure 4-3. Tape Specification

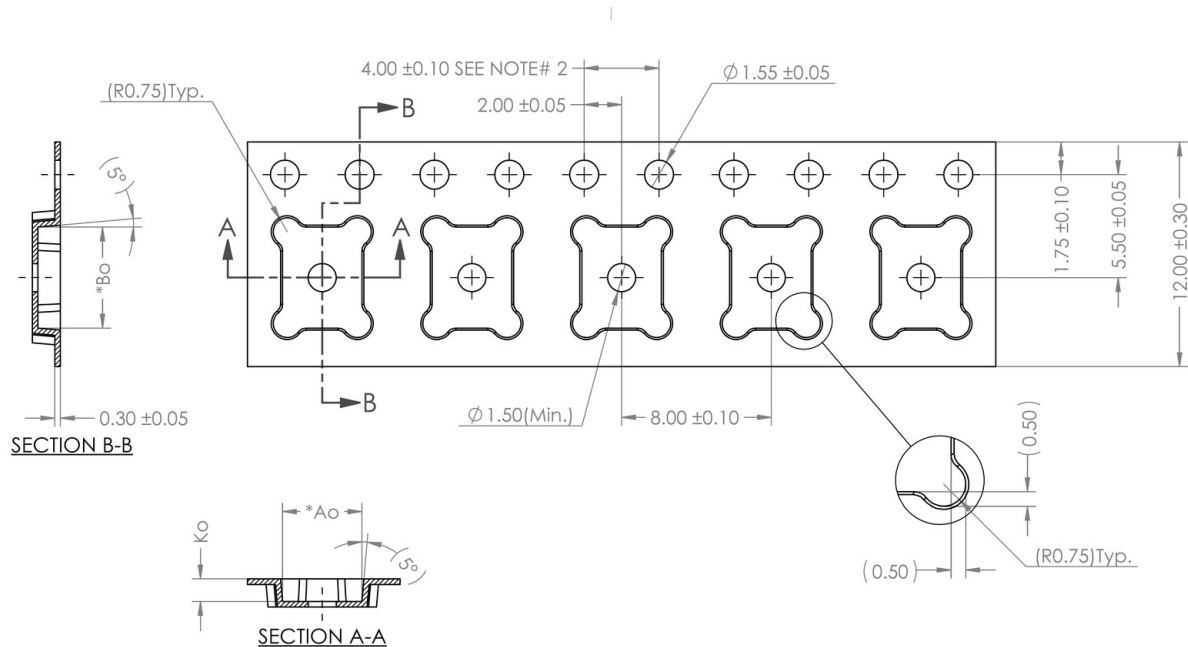

The following table lists the tape mechanical data.

Table 4-4. Tape Mechanical Data

Dimension	Millimeters
A0	4.25 ± 0.10
B0	5.40 ± 0.10
K0	1.20 ± 0.10
K1	—
Pitch	8.00 ± 0.10

.....continued

Dimension	Millimeters
Width	12.00 ±0.30

The following figure shows the reel specification.

Figure 4-4. Reel Specification

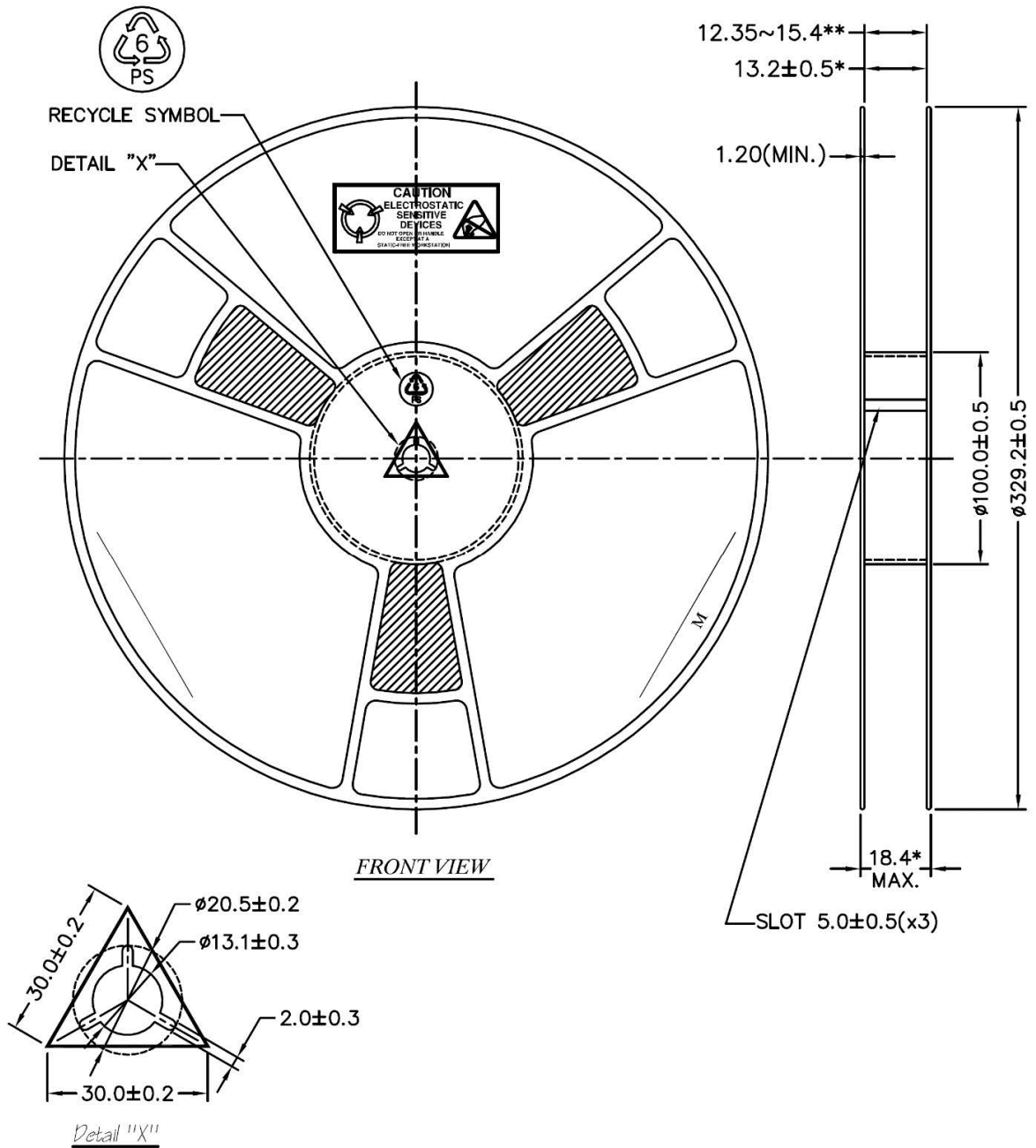

5. Ordering Information

The following table lists the ordering information for the PD69101 device.

Table 5-1. Ordering Information

Part Number	Package	Packaging Type	Temperature	Part Making
PD69101ILQ-TR	Plastic 24-pin QFN: 4 mm × 5 mm	Tape and reel	– 40 °C to 85 °C	MSC 69101 ZZ e3 ¹ YYWWNNN ²

Notes:

1. ZZ e3: ZZ = Random character with no meaning and e3 = Second level interconnect.
2. YY = Year, WW = Week, NNN = Trace Code.

6. Revision History

Revision	Date	Description
A	11/2021	<p>The following is a summary of changes in revision A of this document:</p> <ul style="list-style-type: none"> • The document was updated to latest Microchip template. • The document number was changed from PD-000308061 to DS00004280A.
3.0	8/2019	<p>The following is a summary of changes in revision 3.0 of this document.</p> <ul style="list-style-type: none"> • Changed package marking of Figure 3-1. • Part marking was updated. For more information, see 5. Ordering Information.
2.0	3/2018	<p>The following is a summary of changes in revision 2.0 of this document.</p> <ul style="list-style-type: none"> • Document format was updated. • MSL level was updated from 1 to 3. • 4-pair application was removed. • Tape and Reel—Packaging Information section was added. For more information, see 4.3. Tape and Reel—Packaging Information. • Part marking is updated. For more information, see the 5. Ordering Information.
1.9	3/2014	<p>The following is a summary of changes in revision 1.9 of this document.</p> <ul style="list-style-type: none"> • TETA JB was added. • A typo in the ESD parameter was corrected. • V_{Main} out-of-range information was corrected.
1.8	10/2013	<p>The following is a summary of changes in revision 1.8 of this document.</p> <ul style="list-style-type: none"> • The extended input voltage range was updated to 32V–57V.

.....continued		
Revision	Date	Description
1.7	7/2013	The following is a summary of changes in revision 1.7 of this document. <ul style="list-style-type: none"> • TETA JC data was added.
1.6	7/2013	The following is a summary of changes in revision 1.6 of this document. <ul style="list-style-type: none"> • The IC marking was updated.
1.5	12/2010	The following is a summary of changes in revision 1.5 of this document. <ul style="list-style-type: none"> • Parameters were updated.
1.4	9/2010	The following is a summary of changes in revision 1.4 of this document. <ul style="list-style-type: none"> • Parameters were updated.
1.3	6/2010	The following is a summary of changes in revision 1.3 of this document. <ul style="list-style-type: none"> • Parameters were updated.
1.2	6/2010	The following is a summary of changes in revision 1.2 of this document. <ul style="list-style-type: none"> • Package drawing was updated.
1.1	3/2010	The following is a summary of changes in revision 1.1 of this document. <ul style="list-style-type: none"> • The wave forms and functionality were updated according to evaluation results.
1.0	3/2010	Revision 1.0 was the first publication of this document.

The Microchip Website

Microchip provides online support via our website at www.microchip.com/. This website is used to make files and information easily available to customers. Some of the content available includes:

- **Product Support** – Data sheets and errata, application notes and sample programs, design resources, user's guides and hardware support documents, latest software releases and archived software
- **General Technical Support** – Frequently Asked Questions (FAQs), technical support requests, online discussion groups, Microchip design partner program member listing
- **Business of Microchip** – Product selector and ordering guides, latest Microchip press releases, listing of seminars and events, listings of Microchip sales offices, distributors and factory representatives

Product Change Notification Service

Microchip's product change notification service helps keep customers current on Microchip products. Subscribers will receive email notification whenever there are changes, updates, revisions or errata related to a specified product family or development tool of interest.

To register, go to www.microchip.com/pcn and follow the registration instructions.

Customer Support

Users of Microchip products can receive assistance through several channels:

- Distributor or Representative
- Local Sales Office
- Embedded Solutions Engineer (ESE)
- Technical Support

Customers should contact their distributor, representative or ESE for support. Local sales offices are also available to help customers. A listing of sales offices and locations is included in this document.

Technical support is available through the website at: www.microchip.com/support

Microchip Devices Code Protection Feature

Note the following details of the code protection feature on Microchip products:

- Microchip products meet the specifications contained in their particular Microchip Data Sheet.
- Microchip believes that its family of products is secure when used in the intended manner, within operating specifications, and under normal conditions.
- Microchip values and aggressively protects its intellectual property rights. Attempts to breach the code protection features of Microchip product is strictly prohibited and may violate the Digital Millennium Copyright Act.
- Neither Microchip nor any other semiconductor manufacturer can guarantee the security of its code. Code protection does not mean that we are guaranteeing the product is "unbreakable". Code protection is constantly evolving. Microchip is committed to continuously improving the code protection features of our products.

Legal Notice

This publication and the information herein may be used only with Microchip products, including to design, test, and integrate Microchip products with your application. Use of this information in any other manner violates these terms. Information regarding device applications is provided only for your convenience and may be superseded by updates. It is your responsibility to ensure that your application meets with your specifications. Contact your local Microchip sales office for additional support or, obtain additional support at www.microchip.com/en-us/support/design-help/client-support-services.

THIS INFORMATION IS PROVIDED BY MICROCHIP "AS IS". MICROCHIP MAKES NO REPRESENTATIONS OR WARRANTIES OF ANY KIND WHETHER EXPRESS OR IMPLIED, WRITTEN OR ORAL, STATUTORY OR OTHERWISE, RELATED TO THE INFORMATION INCLUDING BUT NOT LIMITED TO ANY IMPLIED WARRANTIES OF NON-INFRINGEMENT, MERCHANTABILITY, AND FITNESS FOR A PARTICULAR PURPOSE, OR WARRANTIES RELATED TO ITS CONDITION, QUALITY, OR PERFORMANCE.

IN NO EVENT WILL MICROCHIP BE LIABLE FOR ANY INDIRECT, SPECIAL, PUNITIVE, INCIDENTAL, OR CONSEQUENTIAL LOSS, DAMAGE, COST, OR EXPENSE OF ANY KIND WHATSOEVER RELATED TO THE INFORMATION OR ITS USE, HOWEVER CAUSED, EVEN IF MICROCHIP HAS BEEN ADVISED OF THE POSSIBILITY OR THE DAMAGES ARE FORESEEABLE. TO THE FULLEST EXTENT ALLOWED BY LAW, MICROCHIP'S TOTAL LIABILITY ON ALL CLAIMS IN ANY WAY RELATED TO THE INFORMATION OR ITS USE WILL NOT EXCEED THE AMOUNT OF FEES, IF ANY, THAT YOU HAVE PAID DIRECTLY TO MICROCHIP FOR THE INFORMATION.

Use of Microchip devices in life support and/or safety applications is entirely at the buyer's risk, and the buyer agrees to defend, indemnify and hold harmless Microchip from any and all damages, claims, suits, or expenses resulting from such use. No licenses are conveyed, implicitly or otherwise, under any Microchip intellectual property rights unless otherwise stated.

Trademarks

The Microchip name and logo, the Microchip logo, Adaptec, AnyRate, AVR, AVR logo, AVR Freaks, BesTime, BitCloud, CryptoMemory, CryptoRF, dsPIC, flexPWR, HELDO, IGLOO, JukeBlox, KeeLoq, Klear, LANCheck, LinkMD, maXStylus, maXTouch, MediaLB, megaAVR, Microsemi, Microsemi logo, MOST, MOST logo, MPLAB, OptoLyzer, PIC, picoPower, PICSTART, PIC32 logo, PolarFire, Prochip Designer, QTouch, SAM-BA, SenGenuity, SpyNIC, SST, SST Logo, SuperFlash, Symmetricom, SyncServer, Tachyon, TimeSource, tinyAVR, UNI/O, Vectron, and XMEGA are registered trademarks of Microchip Technology Incorporated in the U.S.A. and other countries.

AgileSwitch, APT, ClockWorks, The Embedded Control Solutions Company, EtherSynch, Flashtec, Hyper Speed Control, HyperLight Load, IntellIMOS, Libero, motorBench, mTouch, Powermite 3, Precision Edge, ProASIC, ProASIC Plus, ProASIC Plus logo, Quiet- Wire, SmartFusion, SyncWorld, Temux, TimeCesium, TimeHub, TimePictra, TimeProvider, TrueTime, WinPath, and ZL are registered trademarks of Microchip Technology Incorporated in the U.S.A.

Adjacent Key Suppression, AKS, Analog-for-the-Digital Age, Any Capacitor, AnyIn, AnyOut, Augmented Switching, BlueSky, BodyCom, CodeGuard, CryptoAuthentication, CryptoAutomotive, CryptoCompanion, CryptoController, dsPICDEM, dsPICDEM.net, Dynamic Average Matching, DAM, ECAN, Espresso T1S, EtherGREEN, GridTime, IdealBridge, In-Circuit Serial Programming, ICSP, INICnet, Intelligent Paralleling, Inter-Chip Connectivity, JitterBlocker, Knob-on-Display, maxCrypto, maxView, memBrain, Mindi, MiWi, MPASM, MPF, MPLAB Certified logo, MPLIB, MPLINK, MultiTRAK, NetDetach, NVM Express, NVMe, Omniscient Code Generation, PICDEM, PICDEM.net, PICkit, PICtail, PowerSmart, PureSilicon, QMatrix, REAL ICE, Ripple Blocker, RTAX, RTG4, SAM-ICE, Serial Quad I/O, simpleMAP, SimpliPHY, SmartBuffer, SmartHLS, SMART-I.S., storClad, SQL, SuperSwitcher, SuperSwitcher II, Switchtec, SynchroPHY, Total Endurance, TSHARC, USBCheck, VariSense, VectorBlox, VeriPHY, ViewSpan, WiperLock, XpressConnect, and ZENA are trademarks of Microchip Technology Incorporated in the U.S.A. and other countries.

SQTP is a service mark of Microchip Technology Incorporated in the U.S.A.

The Adaptec logo, Frequency on Demand, Silicon Storage Technology, Symmcom, and Trusted Time are registered trademarks of Microchip Technology Inc. in other countries.

GestIC is a registered trademark of Microchip Technology Germany II GmbH & Co. KG, a subsidiary of Microchip Technology Inc., in other countries.

All other trademarks mentioned herein are property of their respective companies.

© 2021, Microchip Technology Incorporated and its subsidiaries. All Rights Reserved.

ISBN: 978-1-5224-9285-6

Quality Management System

For information regarding Microchip's Quality Management Systems, please visit www.microchip.com/quality.

Worldwide Sales and Service

AMERICAS	ASIA/PACIFIC	ASIA/PACIFIC	EUROPE
<p>Corporate Office 2355 West Chandler Blvd. Chandler, AZ 85224-6199 Tel: 480-792-7200 Tel: 480-792-7277 Technical Support: www.microchip.com/support Web Address: www.microchip.com</p> <p>Atlanta Duluth, GA Tel: 678-957-9614 Fax: 678-957-1455</p> <p>Austin, TX Tel: 512-257-3370</p> <p>Boston Westborough, MA Tel: 774-760-0087 Fax: 774-760-0088</p> <p>Chicago Itasca, IL Tel: 630-285-0071 Fax: 630-285-0075</p> <p>Dallas Addison, TX Tel: 972-818-7423 Fax: 972-818-2924</p> <p>Detroit Novi, MI Tel: 248-848-4000</p> <p>Houston, TX Tel: 281-894-5983</p> <p>Indianapolis Noblesville, IN Tel: 317-773-8323 Fax: 317-773-5453 Tel: 317-536-2380</p> <p>Los Angeles Mission Viejo, CA Tel: 949-462-9523 Fax: 949-462-9608 Tel: 951-273-7800</p> <p>Raleigh, NC Tel: 919-844-7510</p> <p>New York, NY Tel: 631-435-6000</p> <p>San Jose, CA Tel: 408-735-9110 Tel: 408-436-4270</p> <p>Canada - Toronto Tel: 905-695-1980 Fax: 905-695-2078</p>	<p>Australia - Sydney Tel: 61-2-9868-6733</p> <p>China - Beijing Tel: 86-10-8569-7000</p> <p>China - Chengdu Tel: 86-28-8665-5511</p> <p>China - Chongqing Tel: 86-23-8980-9588</p> <p>China - Dongguan Tel: 86-769-8702-9880</p> <p>China - Guangzhou Tel: 86-20-8755-8029</p> <p>China - Hangzhou Tel: 86-571-8792-8115</p> <p>China - Hong Kong SAR Tel: 852-2943-5100</p> <p>China - Nanjing Tel: 86-25-8473-2460</p> <p>China - Qingdao Tel: 86-532-8502-7355</p> <p>China - Shanghai Tel: 86-21-3326-8000</p> <p>China - Shenyang Tel: 86-24-2334-2829</p> <p>China - Shenzhen Tel: 86-755-8864-2200</p> <p>China - Suzhou Tel: 86-186-6233-1526</p> <p>China - Wuhan Tel: 86-27-5980-5300</p> <p>China - Xian Tel: 86-29-8833-7252</p> <p>China - Xiamen Tel: 86-592-2388138</p> <p>China - Zhuhai Tel: 86-756-3210040</p>	<p>India - Bangalore Tel: 91-80-3090-4444</p> <p>India - New Delhi Tel: 91-11-4160-8631</p> <p>India - Pune Tel: 91-20-4121-0141</p> <p>Japan - Osaka Tel: 81-6-6152-7160</p> <p>Japan - Tokyo Tel: 81-3-6880-3770</p> <p>Korea - Daegu Tel: 82-53-744-4301</p> <p>Korea - Seoul Tel: 82-2-554-7200</p> <p>Malaysia - Kuala Lumpur Tel: 60-3-7651-7906</p> <p>Malaysia - Penang Tel: 60-4-227-8870</p> <p>Philippines - Manila Tel: 63-2-634-9065</p> <p>Singapore Tel: 65-6334-8870</p> <p>Taiwan - Hsin Chu Tel: 886-3-577-8366</p> <p>Taiwan - Kaohsiung Tel: 886-7-213-7830</p> <p>Taiwan - Taipei Tel: 886-2-2508-8600</p> <p>Thailand - Bangkok Tel: 66-2-694-1351</p> <p>Vietnam - Ho Chi Minh Tel: 84-28-5448-2100</p>	<p>Austria - Wels Tel: 43-7242-2244-39 Fax: 43-7242-2244-393</p> <p>Denmark - Copenhagen Tel: 45-4485-5910 Fax: 45-4485-2829</p> <p>Finland - Espoo Tel: 358-9-4520-820</p> <p>France - Paris Tel: 33-1-69-53-63-20 Fax: 33-1-69-30-90-79</p> <p>Germany - Garching Tel: 49-8931-9700</p> <p>Germany - Haan Tel: 49-2129-3766400</p> <p>Germany - Heilbronn Tel: 49-7131-72400</p> <p>Germany - Karlsruhe Tel: 49-721-625370</p> <p>Germany - Munich Tel: 49-89-627-144-0 Fax: 49-89-627-144-44</p> <p>Germany - Rosenheim Tel: 49-8031-354-560</p> <p>Israel - Ra'anana Tel: 972-9-744-7705</p> <p>Italy - Milan Tel: 39-0331-742611 Fax: 39-0331-466781</p> <p>Italy - Padova Tel: 39-049-7625286</p> <p>Netherlands - Drunen Tel: 31-416-690399 Fax: 31-416-690340</p> <p>Norway - Trondheim Tel: 47-72884388</p> <p>Poland - Warsaw Tel: 48-22-3325737</p> <p>Romania - Bucharest Tel: 40-21-407-87-50</p> <p>Spain - Madrid Tel: 34-91-708-08-90 Fax: 34-91-708-08-91</p> <p>Sweden - Gothenberg Tel: 46-31-704-60-40</p> <p>Sweden - Stockholm Tel: 46-8-5090-4654</p> <p>UK - Wokingham Tel: 44-118-921-5800 Fax: 44-118-921-5820</p>