



Product Change Notification - SYST-10FRAP496

Date: 11 Mar 2016
Product Category: EQCOLogic
Affected CPNs:  
Notification subject: Data Sheet - EQCO62T20.3 and EQCO31T20.3 Data Sheet Data Sheet Document Revision
Notification text: SYST-10FRAP496

Microchip has released a new DeviceDoc for the EQCO62T20.3 and EQCO31T20.3 Data Sheet of devices. If you are using one of these devices please read the document located at [EQCO62T20.3 and EQCO31T20.3 Data Sheet](#).

Notification Status: Final

Description of Change: 1) Updated Section 4.0 "Packaging Information". 2) Removed electrostatic discharge ratings from Table 3-1. 3) Minor typographical changes

Impacts to Data Sheet: None

Reason for Change: To Improve Productivity

Change Implementation Status: Complete

Date Document Changes Effective: 11 Mar 2016

NOTE: Please be advised that this is a change to the document only the product has not been changed.

Markings to Distinguish Revised from Unrevised Devices: N/A

Attachment(s): [EQCO62T20.3 and EQCO31T20.3 Data Sheet](#)

Please contact your local [Microchip sales office](#) with questions or concerns regarding this notification.

Terms and Conditions:

If you wish to change your product/process change notification (PCN) profile please log on to our website at

To opt out of future offer or information emails (other than product change notification emails), click here to go to [microchipDIRECT](#) and login, then click on the "My account" link, click on "Update profile" and un-check the box that states "Future offers or information about Microchip's products or services."

Affected Catalog Part Numbers (CPN)

EQCO62T20.3-TRAY

EQCO62T20.3

EQCO31T20.3-TRAY

EQCO31T20.3

EQCO62T20.3 6.25 Gbps Asymmetric Coax Driver

EQCO31T20.3 3.125 Gbps Asymmetric Coax Driver

Features

- Complies with the CoaXPress v1.1 Camera Standard ⁽¹⁾
- Supports up to 68 Meters of Cable at 6.25 Gbps Using High-Quality Coax
- Supports up to 212 Meters of Cable at 1.25 Gbps Using High-Quality Coax
- Single-Chip Solutions for Both the Camera Side and the Frame Grabber Side, Making a Bidirectional Connection Over a Single 75Ω Coax Cable
- Full-Duplex, Bidirectional Data Channel
 - Downlink Speeds from 1.25 Gbps up to 6.25 Gbps; Differential Interfacing Straightforward with Internal Termination Resistors
 - Uplink Supporting 21 Mbps, Allowing Nanoseconds Precise Triggering Events Driven by the Frame Grabber
- Supports Power Distribution Over the Coax up to 900 mA, Powering the Camera Through the Same Coax Transporting Data Signals
- Low Power Consumption (<70 mW, 1.2V supply)
- 16-Pin, 0.65 mm Pin Pitch, 4 mm QFN Package
- Small PCB Footprint for EQCO62T20 and Off-Chip Components, with Guaranteed RF-Performance
- -40°C to +85°C Industrial Temperature Range
- Pb-Free and RoHS Compliant

Applications

- High-Definition/High-Bandwidth Links to Cameras
- Machine Vision for Semiconductor Chips and Display Panel Inspection Systems
- Military, Aerospace, Medical Applications
- Broadcast and Surveillance Camera Systems
- Traffic License Plate and Monitoring Systems
- High-Speed Inspection Systems for Food Inspection, Bottling Inspection, Panel Inspection, etc.
- Any application requiring a single coax cable which carries power, video data and camera control stream

Introduction

The EQCO62T/R20⁽²⁾ chipset is a driver/equalizer chipset that forms a bidirectional, full-duplex communication link over a single coax cable.

The EQCO62T/R20 chipset is designed to transport up to 6.25 Gbps over the downlink channel and to transport 21 Mbps over the uplink channel. The EQCO62T20 is designed to transmit the downlink signal up to 6.25 Gbps and receive the uplink signal. The EQCO62R20 is designed to receive the downlink signal up to 6.25 Gbps and to transmit the uplink signal. Power can be transferred over the same cable via external inductors.

The chipset is designed to work with several types of 75Ω coaxial cables, including legacy cables as well as thin, flexible lightweight cables.

Note 1: CoaXPress V1.1 standard. Free download from the J11A website:

2: The EQCO31T20 and EQCO31R20 are lower-speed versions of the EQCO62T20 and EQCO62R20, with a maximum bit rate of 3.125 Gbps for the high-speed downlink and the same uplink speed.

EQCO62T20.3/EQCO31T20.3

Typical Link Performance

Table 1, Table 2 and Table 3 give an overview of typical link performance at room temperature for the link containing the EQCO62T20 coax driver in conjunction with the EQCO62R20 receiver, using the downlink channel, uplink channel and power transmission simultaneously. Performance for EQCO62T/R20 and EQCO31T/R20 is equal for bit rates up to 3.125 Gbps.

TABLE 1: BELDEN TYPICAL LINK PERFORMANCE

	Name	Belden 7731A	Belden 1694A	Belden 1505A	Belden 1505F	Belden 1855A
	Type	Long Distance	Industry Standard	Compromise Coax	Flexible	Thinnest Cable
Diameter	(mm)	10.3	6.99	5.94	6.15	4.03
1.25 Gbps	(m)	194	130	107	80	55
2.5 Gbps	(m)	162	110	94	66	55
3.125 Gbps	(m)	147	100	86	60	55
5.0 Gbps	(m)	87	60	52	35	38
6.25 Gbps	(m)	58	40	35	23	25

TABLE 2: GEPSCO TYPICAL LINK PERFORMANCE

	Name	Gepco VHD1100	Gepco VSD2001	Gepco VPM2000	Gepco VHD2000M	Gepco VDM230
	Type	Long Distance	Industry Standard	Compromise Coax	Flexible	Thinnest Cable
Diameter	(mm)	10.3	6.91	6.15	6.15	4.16
1.25 Gbps	(m)	212	140	109	81	66
2.5 Gbps	(m)	185	120	94	67	66
3.125 Gbps	(m)	169	110	86	61	62
5.0 Gbps	(m)	102	66	53	36	38
6.25 Gbps	(m)	68	44	35	24	25

TABLE 3: CANARE TYPICAL LINK PERFORMANCE⁽¹⁾

	Name	Canare L-7CFB	Canare L-5CFB	Canare L-4CFB	Canare L-3CFB	Canare L-2.5CFB
	Type	Long Distance	Industry Standard	Compromise Coax	Thin Cable	Thinnest Cable
Diameter	(mm)	10.2	7.7	6.1	5.5	4
1.25 Gbps	(m)	165	118	94	72	43
2.5 Gbps	(m)	135	98	79	66	43
3.125 Gbps	(m)	122	88	71	60	43
5.0 Gbps	(m)	71	52	42	36	30
6.25 Gbps	(m)	46	34	28	24	20

Note 1: Specifications from Canare are only up to 2 GHz. 5 Gbps and 6.25 Gbps performance are by extrapolation.

Table of Contents

1.0 Device Overview	4
2.0 Application Information	8
3.0 Electrical Characteristics	15
4.0 Packaging	17

TO OUR VALUED CUSTOMERS

It is our intention to provide our valued customers with the best documentation possible to ensure successful use of your Microchip products. To this end, we will continue to improve our publications to better suit your needs. Our publications will be refined and enhanced as new volumes and updates are introduced.

If you have any questions or comments regarding this publication, please contact the Marketing Communications Department via E-mail at docerrors@microchip.com or fax the **Reader Response Form** in the back of this data sheet to (480) 792-4150. We welcome your feedback.

Most Current Data Sheet

To obtain the most up-to-date version of this data sheet, please register at our Worldwide Web site at:

You can determine the version of a data sheet by examining its literature number found on the bottom outside corner of any page. The last character of the literature number is the version number, (e.g., DS30000A is version A of document DS30000).

Errata

An errata sheet, describing minor operational differences from the data sheet and recommended workarounds, may exist for current devices. As device/documentation issues become known to us, we will publish an errata sheet. The errata will specify the revision of silicon and revision of document to which it applies.

To determine if an errata sheet exists for a particular device, please check with one of the following:

- Microchip's Worldwide Web site;

When contacting a sales office, please specify which device, revision of silicon and data sheet (include literature number) you are using.

Customer Notification System

Register on our web site at * [www.microchip.com](#) for the most current information on all of our products.

EQCO62T20.3/EQCO31T20.3

1.0 DEVICE OVERVIEW

The EQCO62T/R20 single-coax chipset is designed to simultaneously transmit and receive signals along with power on a single 75Ω coax cable. In one direction, a downlink signal is transmitted. In the opposite direction, a lower-speed uplink is provided. The EQCO62T/R20 chipset consists of two chips. The EQCO62T20 is a high-speed line driver with an integrated low-speed receiver. The EQCO62R20 is a high-speed receiver with an integrated low-speed transmitter. Figure 1-1 illustrates a typical EQCO62T/R20 link setup.

The downlink signal is transmitted with 600 mV transmit amplitude at the EQCO62T20 side. This signal is attenuated in the coax and recovered by an equalizer integrated in the EQCO62R20. The low-speed uplink is transmitted with a lower amplitude of 130 mV to limit the crosstalk with the downlink channel.

The downlink channel is intended for 8B/10B NRZ coded data with bitrates from 1.25 Gbps up to 6.25 Gbps. The low-speed uplink operates at a bit rate of 21 Mbps, and has a single-ended LVTTLL input and output.

In addition to the downlink channel and the low-speed uplink, the system allows power transmission over the coax by using ferrite beads and external inductors. These external inductors give the communication channel a high-pass characteristic. The uplink receiver inside the EQCO62T20 chip recovers the signal lost by this high-pass filter. Appropriate inductors need to be selected for correct operation of the link. Correct operation is only guaranteed with the inductor combination used in Figure 2-1, even though other components might be suited.

The EQCO62T/R20 chipset is compatible with the CoaXPress v1.1 camera standard.

FIGURE 1-1: TYPICAL EQCO62T/R20 LINK SETUP

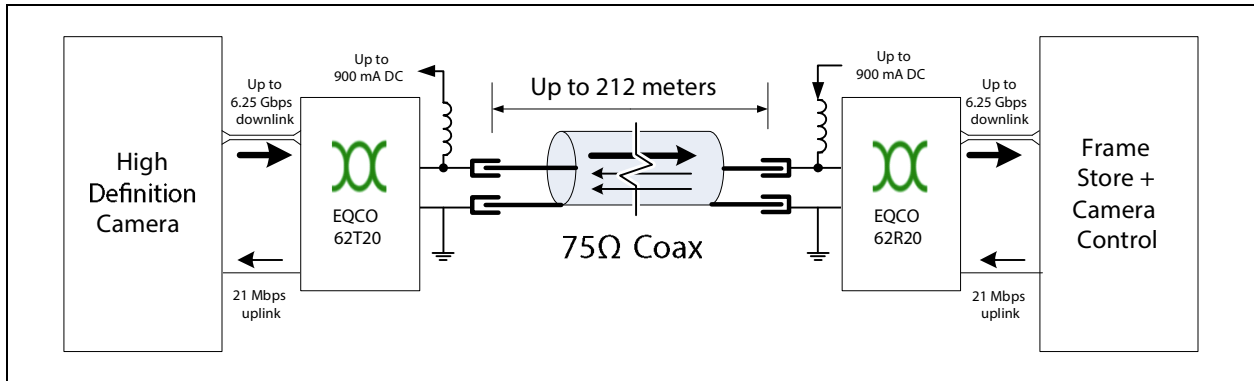

EQCO62T20.3/EQCO31T20.3

1.1 Pinout and Pin Description

FIGURE 1-2: EQCO62T20.3 PIN DIAGRAM(VIEWED FROM TOP)

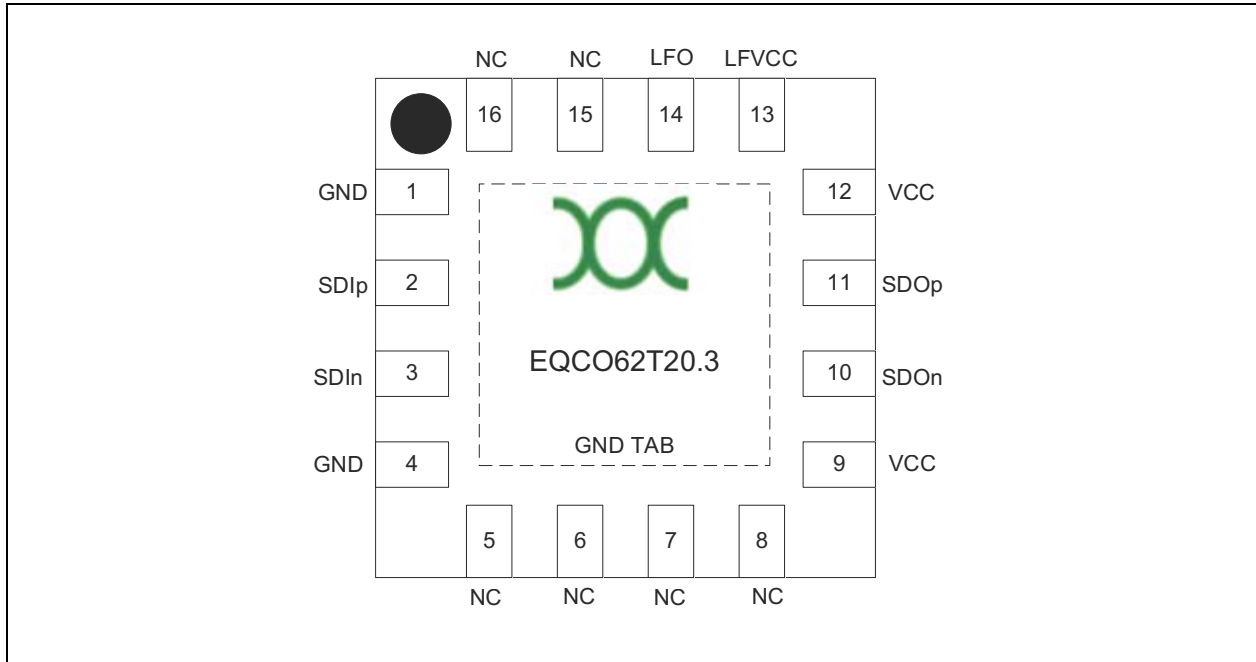

TABLE 1-1: EQCO62T20.3 PIN DESCRIPTIONS

Pin Number	Pin Name	Signal Type	Description
(TAB)	GND	Power	Connect to ground.
9, 12	VCC	Power	Connect to +1.2V of power supply.
1, 4	GND	Power	Connect to ground of power supply.
2, 3	SDIp/SDIn	Differential Input	Serial input positive/negative differential serial input. Typical input swing is 2x300 mV. Minimal input swing is 2x250 mV. 2x50Ω on-chip termination resistor.
11, 10	SDOp/SDOn	Differential Output	Differential serial output pair. On-Chip 75Ω termination resistors. SDOp is connected to the coax cable by a capacitor. SDOn needs to be connected to GND by 75Ω termination resistor and capacitor. Swing is fixed to VCC/2.
13	LfVCC	Power	Power supply for the uplink output (between 1.2V and 3.3V).
14	LFO	Output	Low-frequency uplink output. LVTTTL with output swing equal to LfVCC. Supports capacitive loads up to 20 pF for 21 Mbps operation.
5, 6, 7, 8, 15, 16	NC	—	Do not connect. Leave these pins floating. Used for internal testing.

EQCO62T20.3/EQCO31T20.3

1.1.1 SDIp/SDIn

SDIp/SDIn together form a differential input pair. The serial data received on these pins will be transmitted on SDOp/SDOn. The input pre-driver automatically corrects for variations in signal levels and different edge slew rates at these inputs before they go into the active splitter/combiner for transmission over the coax.

Between SDIp and SDIn inputs, there is a termination resistor of 100Ω. The intention is to always use AC coupling.

A transmit wake-up detection circuit puts both the input pre-driver and the output driver into a low-power mode when no signal is detected on the SDIp/SDIn signal pair.

1.1.2 SDOp/SDOn

The signal at the inputs SDIp/SDIn is transmitted onto the cable by outputs SDOp/SDOn. Both outputs are internally terminated with 75Ω.

The signal on the SDOp pin is the sum of the incoming signal (i.e. the signal transmitted by the EQCO62R20 on the far end side of the coax) and the outgoing signal (i.e. the signal created based on SDIp/SDIn). The far-end signal is extracted by subtraction of the near-end signal and the far-end signal, and is restored by the uplink receiver inside the EQCO62T20 chip. The SDOn signal carries a precise anti-phase signal to the transmitted signal on SDOp. SDOn must be connected directly to GND at the connector via a resistor precisely matched to the impedance of the coaxial cable used and an AC coupling capacitor.

1.1.3 LFO

LFO is the output of the uplink receiver inside the EQCO62T20. The maximum allowed capacitance at the output is 20 pF, with rise and fall times of 5 ns. The maximum output current is 1 mA when Lfvcc is 3.3V.

1.1.4 Lfvcc

The output driver of the uplink receiver in the EQCO62T20 has a separate power supply pin. The power supply voltages can be 1.2V up to 3.3V. The output swing at LFO is equal to this power supply voltage. A filter capacitor must be placed close to the Lfvcc pin of the EQCO62T20.

EQCO62T20.3/EQCO31T20.3

1.2 Circuit Operation

FIGURE 1-3: EQCO62T20.3 BLOCK DIAGRAM SHOWING ELECTRICAL CONNECTIONS

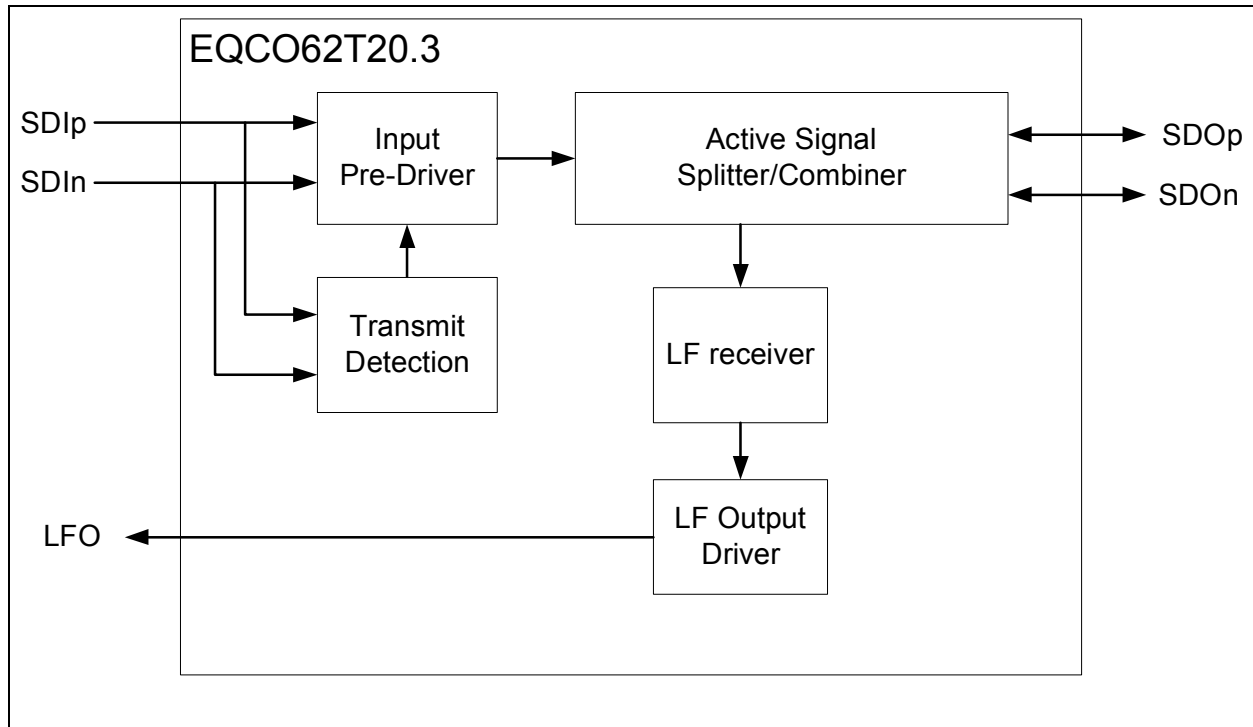

1.2.1 PRE-DRIVER

The pre-driver removes any dependency for the amplitude and rise time of the incoming signal on SDI.

1.2.2 ACTIVE SIGNAL SPLITTER/COMBINER

The active splitter/combiner controls the amplitude and rise time of the outgoing coax signal and transmits it via a 75Ω output termination resistor. The output resistor, when balanced with the coax characteristic impedance, also forms part of a hybrid splitter circuit which subtracts the TX output from the signal on the SDO output to give yield the far-end TX signal.

1.2.3 TRANSMIT DETECTION

The transmit detection detects if an input signal is applied at SDI. The detection circuit looks at the signal amplitude of SDI; if no signal is detected, the pre-driver and output driver are disabled. The LF receiver then continues to operate independently. At the moment the output driver is turned on or off, there can be a bit error in the uplink channel, e.g. by the LF-receiver.

1.2.4 LF RECEIVER

The uplink receiver removes unwanted crosstalk from the transmitted near-end signal. Afterwards, the uplink signal is restored by detecting edges coming from the uplink signal. At the moment the high-speed output driver is turned on or off, there can be a bit error in the uplink channel, e.g. by the LF-receiver. The initial output state of the LF receiver can be wrong, and subsequent bits will still be received correctly.

1.2.5 LF OUTPUT DRIVER

The uplink output driver converts the signal detected by the LF receiver to an LVTTTL signal with a controlled rise and fall time. It is required to set the output signal amplitude of this LVTTTL signal by connecting the Lfvcc to the appropriate power supply voltage (max 3.3V).

EQCO62T20.3/EQCO31T20.3

2.0 APPLICATION INFORMATION

Figure 2-1 illustrates a typical schematic implementation.

FIGURE 2-1: EQCO62T20.3 TYPICAL APPLICATION CIRCUIT

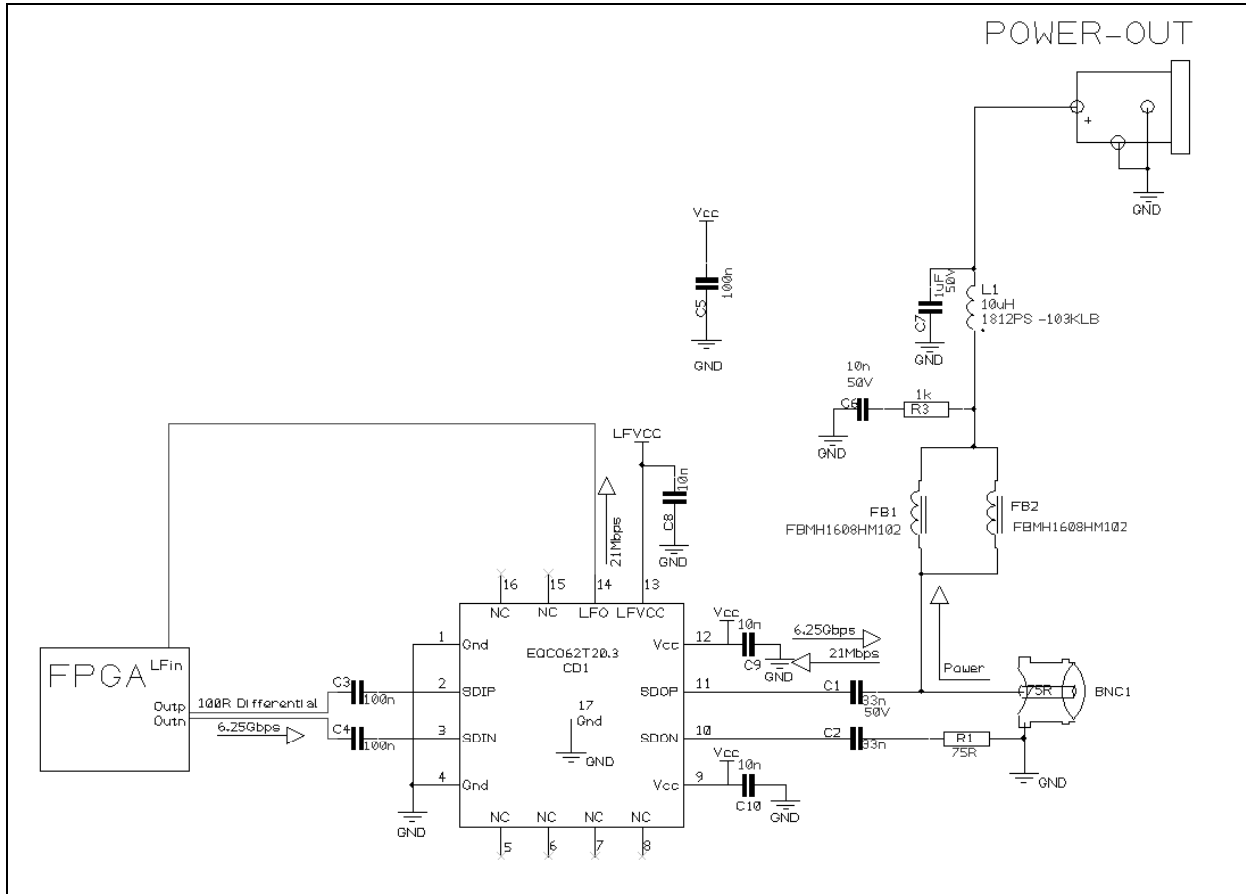

TABLE 2-1: COMPONENT RECOMMENDATION FOR THE EQCO62T20.3 BOARD LAYOUT

Element	Value	Size	Recommended Component
Fb1, Fb2	1 kΩ @ 100 MHz Ferrite Bead	0603	FBMH1608HM102 from Taiyo Yuden (Critical)
L1	10 μH	1812	1812PS_103 from Coilcraft (Critical)
R1	75Ω ±1%	0402	
R3	1 kΩ	0402	
C1	33 nF, 50V, X7R	0603	
C2	33 nF, X7R	0402/0603	
C3, C4, C5	100 nF, X7R	0402	
C6	10 nF, 50V, X7R	0402	
C7	1 μF, 50V, X7R	0805	
C8, C9, C10	10 nF, X7R	0402	
BNC1	75Ω right angle BNC connector		5413558-1 from Tyco (Recommended)

Ferrite Beads Fb1 and Fb2 (FBMH1608HM102 from Taiyo Yuden) and inductor L1 (1812PS_103 from Coilcraft [10 μH]) are recommended for CoaXPress. For other applications the inductor value can be larger, leading to a physical larger inductor.

Connector BNC1 (75Ω right angle BNC connector 5413558-1 from Tyco) is recommended for CoaXPress.

Other inductors/ferrite beads/BNC connectors can possibly be used, however, they must be selected carefully for their RF-performance, since performance can decrease significantly.

EQCO62T20.3/EQCO31T20.3

2.1 Guidelines for PCB Layout

When using the EQCO62T/R20 chipset at its full purpose, including low-speed uplink and power supply transmission, it is important not to disturb the RF-performance of the high-speed downlink channel. Implementing the circuit illustrated in Figure 2-1 with a different PCB layout will in first instance not deliver full data sheet performance. The simplest way of meeting optimal performance, including jitter and return-loss requirements, is to precisely follow the component and layout recommendations. Note that at multi-gigabit speeds, using "equivalent" components or small PCB layout changes (even moving a via) can have significant detrimental effects.

The easiest way for achieving the requirements of the CoaXPress 1.1 specification is to use the recommended circuits, components and layout illustrated in Figure 2-1. For easy implementation, Microchip will provide the Gerber file. Please ask for it by email.

Note: Email address: coaxpress@microchip.com

2.1.1 RIGHT ANGLE BNC

Figure 2-2 below shows the four layers of the recommended footprint for the EQCO62T20.3 chip and the off-chip components that are critical for the RF-performance of the system.

FIGURE 2-2: RECOMMENDED PCB LAYOUT FOR EQCO62T20.3

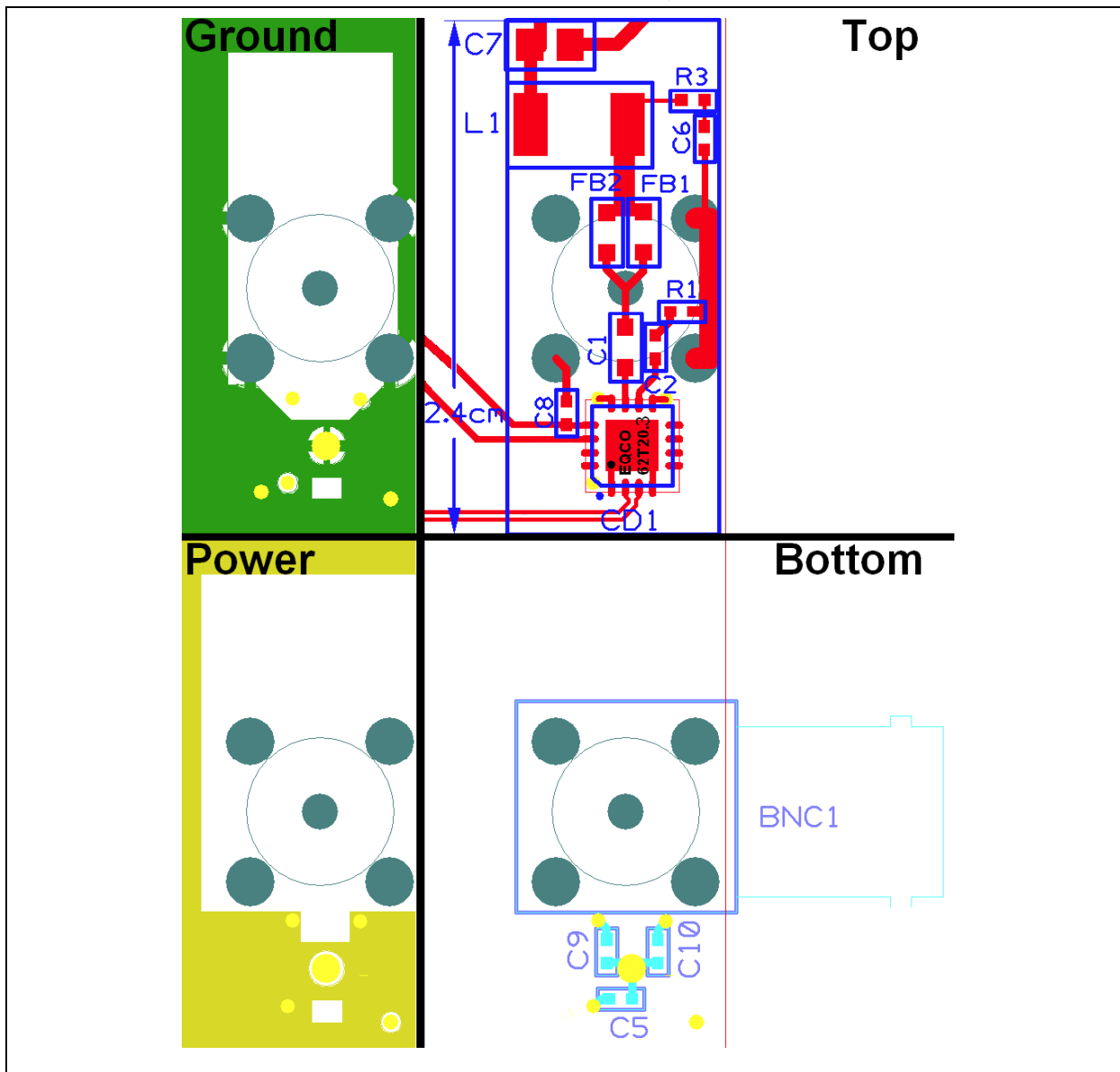

EQCO62T20.3/EQCO31T20.3

In this layout, the size of the PCB area needed for the chip is minimized. Approximately two times the BNC footprint area is required for the full bidirectional system: including the necessary elements for the power transport.

The differential input of the chip must be be a 100Ω differential transmission line. To minimize the parasitic capacitance of the input pins, a cut-out of the ground and power plane underneath the input pins is recommended. For best performance, no vias should be used in this high-speed signal path.

A large cut-out underneath the right angle BNC connector, the AC coupling capacitors, ferrite beads and inductor is needed for minimal parasitics.

This proposed layout is designed to be largely independent of the used PCB-layer stack. This will work as well for four, six or even higher numbers of layers. Possible extra layers should have cut-outs as large as the full proposed footprint.

FIGURE 2-3: PCB LAYOUT OF MULTILANE COAXPRESS 0V1 DEMO BOARD PAIR

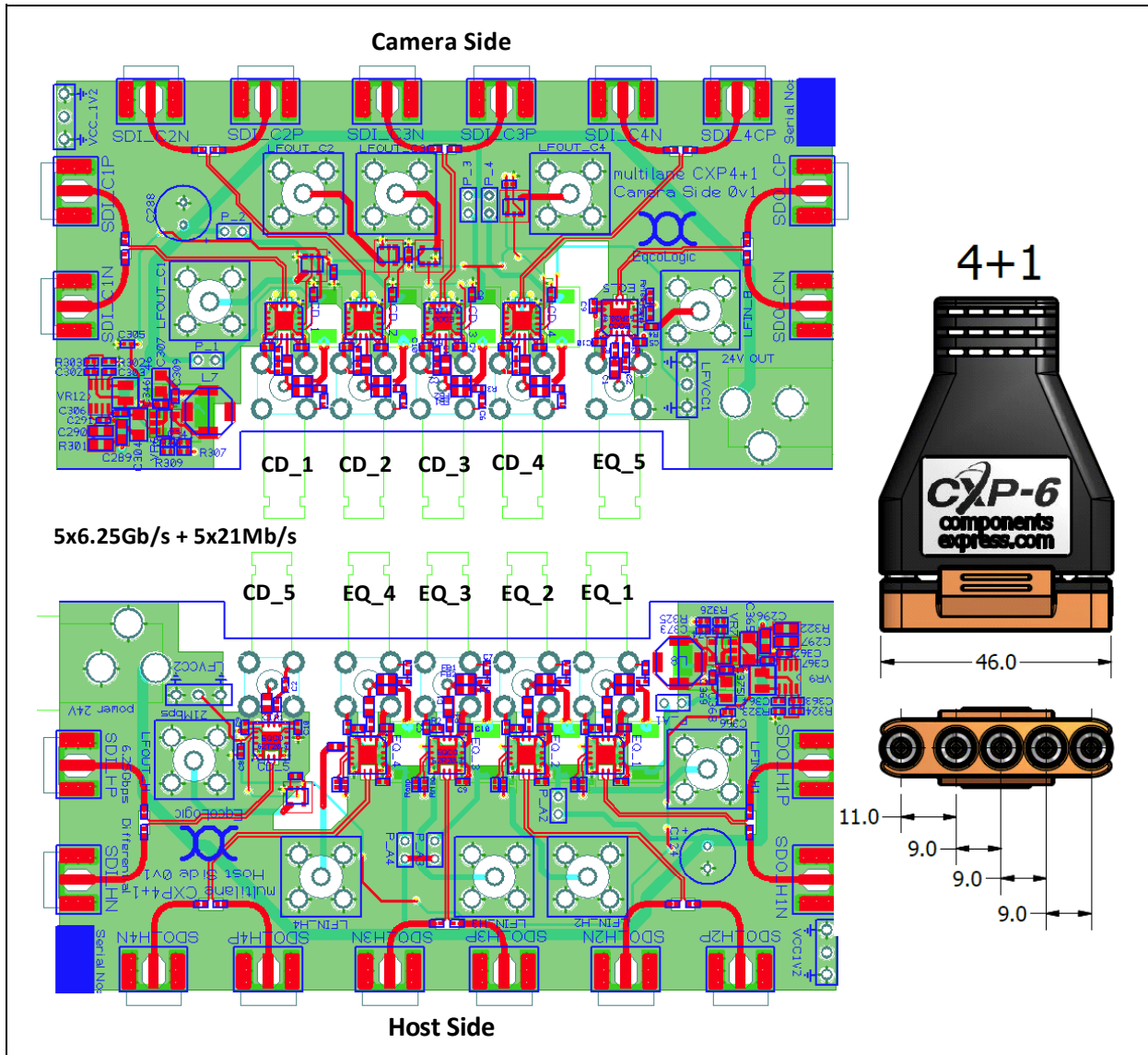

2.1.2 MULTILANE COAXPRESS 4+1 LAYOUT WITH DIN1.0/2.3 CONNECTORS

Figure 2-3 shows an example of a Multilane CoaXPress 4+1 setup. The recommended Din1.0/2.3 connector is the NPF 4076 from Cambridge Connectors. The cable example shows the pitches in millimeters. Figure 2-4 shows the four layers of the recommended footprints and the off-chip components that are critical for RF-performance of the cable drivers CD_1 to CD_4 at the camera side, which have Power over CoaXPress (PoCXP). Figure 2-5 shows the variant without PoCXP used for CD_5 at the host side. The exact dimensions in millimeters are given in Section 4.1 “Package Marking Information”. It is recommended to copy these dimensions, especially the connection between the DIN1.0/2.3 connector and the chip, as this is a complex entity with coupled currents and compensated parasitic capacitances.

Despite the critical layout, this proposed layout is designed to be largely independent of the used PCB-layer stack, as the critical parts are mainly the top-layer only. This will work as well for four, six or even higher numbers of layers. Possible extra layers should have cut-outs as large as the full proposed footprint.

In these layouts, the size of the PCB area needed for the chip is minimized. This allows multiple lanes close together.

Only two of four connector GND pins are connected to the GND plane to reduce the capacitance.

The differential CD inputs must be a 100Ω differential transmission line. A cut-out of the ground and power plane underneath the input pins is recommended to minimize the parasitic capacitance. For best performance, no vias should be used in this high-speed signal path.

The Components Express 4+1 connector in Figure 2-3 is only shown as an example. Other connector configurations are available with DIN1.0/2.3 connectors such as 6+1, 2+1, 1+1, dual or single lane configurations.

EQCO62T20.3/EQCO31T20.3

FIGURE 2-4: RECOMMENDED PCB LAYOUT FOR EQCO62T20.3 WITH DIN1.0/2.3 CONNECTOR WITH PoCXP

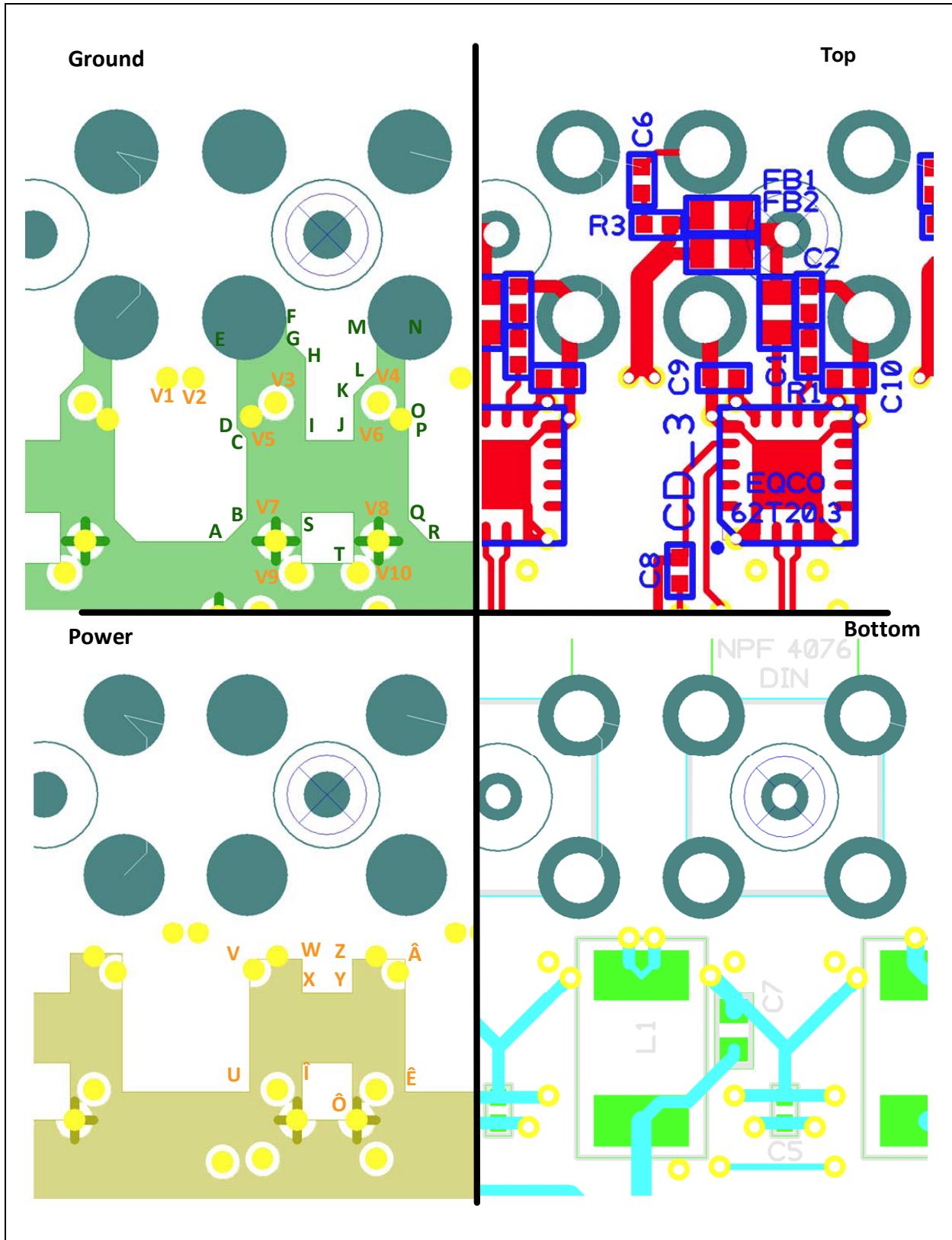

EQCO62T20.3/EQCO31T20.3

FIGURE 2-5: RECOMMENDED PCB LAYOUT FOR EQCO62T20.3 WITH DIN1.0/2.3 CONNECTOR WITHOUT PoCXP

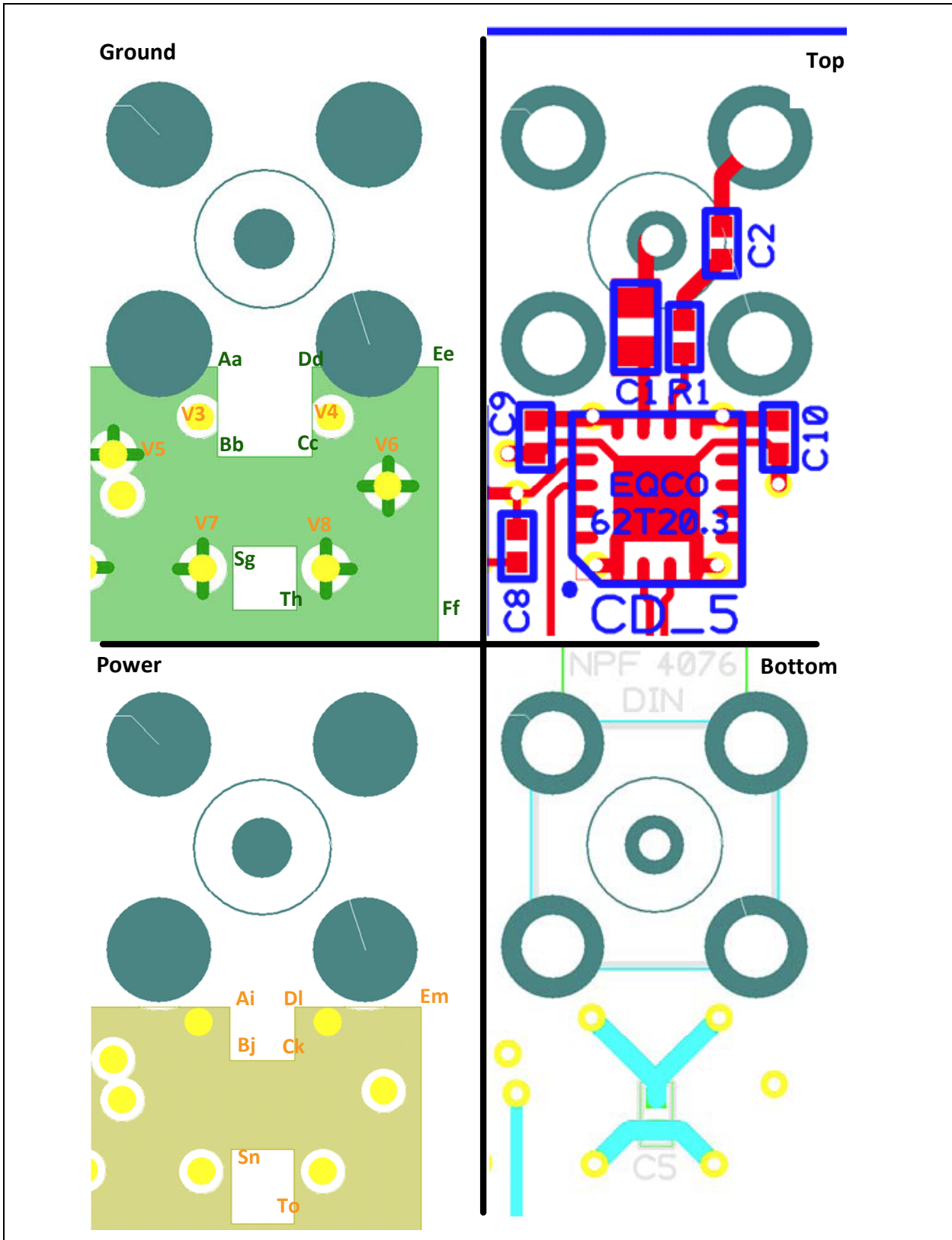

EQCO62T20.3/EQCO31T20.3

2.2 Guidelines for Power Receive Unit

At the Power-OUT connection, the voltage supply for the camera (including the power supply for the EQCO62T20.3) is expected.

This load current should have low ripple. High-frequency ripple will be rejected by C7/L1/FB1/FB2 filtering in the reference circuit. However, mid-frequency ripple is to be avoided by the power supply itself.

In a typical application, one could want to step-down from the 24V supply to all supply voltages needed inside the camera. It is in this case preferred to use a DC-to-DC converter that has a high switching frequency (e.g. 2 MHz) above one that has lower switching frequency (200 kHz). The latter typically induces larger voltage spikes at the Power-OUT connection. These will be only partially filtered out by said filter; the remainder will become crosstalk for the uplink channel.

When too much crosstalk remains on the uplink channel, additional power supply filtering is required. This may be achieved by placing an extra filter network (not shown) in series with the Power-OUT node.

2.3 Power Over CoaXPress

The EQCO62T20.3 is compatible with the Power over CoaXPress system (PoCXP). Hence, power can be switched on and off by the host (e.g. frame grabber) through the 10 μ H inductor specified by the CXP standard. This switching is supported through a relay and through an electronic switch.

Powering through a wide-band bias-T is also supported.

The EQCO62T20.3 is also protected against the following events:

- Hot plugging by frame grabber: in case the frame grabber has already applied its 24V on the coax when connecting the cable, no damage will occur to the EQCO62T20.3 when connecting the powered coax cable.
- Fast turn on and turn off of power supply by frame grabber

Direct 24V application, i.e. not through a 10 μ H inductor, is not supported since it causes permanent damage to the EQCO62T20 device.

EQCO62T20.3/EQCO31T20.3

3.0 ELECTRICAL CHARACTERISTICS

3.1 Absolute Maximum Ratings

Stresses beyond those listed under this section may cause permanent damage to the device. These are stress ratings only and are not tested. Functional operation of the device at these or any other conditions beyond those indicated in the operational sections is not implied. Exposure to absolute maximum rating conditions for extended periods may affect device reliability.

TABLE 3-1: ABSOLUTE MAXIMUM RATINGS

Parameter	Conditions	Min.	Typ.	Max.	Units
Storage Temperature		-65	—	+150	°C
Ambient Temperature	Power Applied	-55	—	+125	°C
Operating Temperature	Normal Operation (VCC = 1.2V ±5%)	-40	—	+85	°C
Supply Voltage to Ground		-0.5	—	+1.4	V
DC Input Voltage		-0.5	—	+1.6	V
DC Voltage to Outputs		-0.5	—	+1.6	V
Current into Outputs	Outputs Low	—	—	90	mA

TABLE 3-2: ELECTRICAL CHARACTERISTICS (OVER THE OPERATING VCC AND -40 TO +85°C RANGE)

Parameter	Description	Min.	Typ.	Max.	Unit
Power Supply					
VCC	Supply Voltage	1.15	1.2	1.25	V
I _s	Supply Current, both Transmitting and Receiving	—	60	—	mA
I _{sr}	Supply Current when only Receiving	—	30	—	mA
SDIp/SDIn Input					
ΔV _i	Input Amplitude V _{SDip,n}	2x250	2x300	—	mV
V _{turnon}	ΔVi to Turn On Transmit Function	—	2x150	2x250	mV
V _{turnoff}	ΔVi to Turn Off Transmit Function	2x50	2x150	—	mV
R _{input}	Differential Input Termination	—	2x50	—	Ω
SDOp Connection to Coax					
Z _{coax}	Coax Cable Characteristic Impedance	—	75	—	Ω
R _{SDOp}	Input Impedance between SDOp and VCC/GND	—	75	—	Ω
R _{loss}	Coax Return Loss as Seen on SDOp pin Frequency Range = 5 MHz-1 GHz	—	—	-15	dB
R _{loss}	Coax Return Loss as Seen on SDOp pin Frequency Range = 1 GHz-1.5 GHz	—	—	-10	dB
R _{loss}	Coax Return Loss as Seen on SDOp pin Frequency Range = 1.5 GHz-3.2 GHz	—	—	-7	dB
ΔV _{Tx}	Transmit Amplitude	500	600	700	mV
t _{rise_tx}	Rise/Fall Time 20% to 80% of ΔVtx	—	—	80	ps
DCD	Duty Cycle Distortion on of V _{SDOp}	—	5	—	ps

EQCO62T20.3/EQCO31T20.3

TABLE 3-2: ELECTRICAL CHARACTERISTICS (OVER THE OPERATING VCC AND -40 TO +85°C RANGE) (CONTINUED)

LFO Output (LVTTTL-Like)					
LFVCC	Uplink Output Driver Power Supply	1.2	—	3.3	V
t _{rise_LFO}	Rise/Fall Time 20% to 80% of VLFO for 20 pF Load LFVCC = 1.2V	—	6	—	ns
	LFVCC = 3.3V	—	5	—	ns

TABLE 3-3: JITTER NUMBERS

Parameter	Conditions	Min.	Typ.	Max.	Units
Additive Peak to Peak Jitter on SDOp/SDOn (EQCO62T20)	Downlink Signal = 1.25 up to 6.25 Gbps, prbs7	—	—	30	ps
EQCO31T20	Downlink Signal = 1.25 up to 3.125 Gbps, prbs7	—	—	30	ps
Peak to Peak Jitter on LFO	0-130m Belden 1694A coax, Over Full VCC and Temperature Range; Low-Speed Signal = 21 Mbps, 8B/10B, Downlink Signal= 1.25-6.25 Gbps,8B/10B	—	—	15	ns

EQCO62T20.3/EQCO31T20.3

4.0 PACKAGING INFORMATION

4.1 Package Marking Information

16-Lead Plastic Quad Flat, No Lead Package – 4x4x0.9 mm Body [QFN]

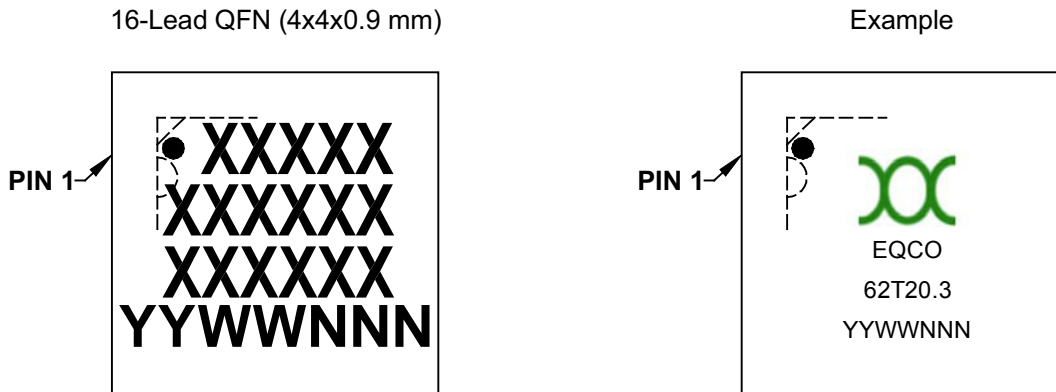

Legend:	XX...X	Customer-specific information
	Y	Year code (last digit of calendar year)
	YY	Year code (last 2 digits of calendar year)
	WW	Week code (week of January 1 is week '01')
	NNN	Alphanumeric traceability code
	(e3)	Pb-free JEDEC designator for Matte Tin (Sn)
	*	This package is Pb-free. The Pb-free JEDEC designator (e3) can be found on the outer packaging for this package.

Note: In the event the full Microchip part number cannot be marked on one line, it will be carried over to the next line, thus limiting the number of available characters for customer-specific information.

EQCO62T20.3/EQCO31T20.3

16-Lead Plastic Quad Flat, No Lead Package (8E) - 4x4x0.9 mm Body [QFN]

Note: For the most current package drawings, please see the Microchip Packaging Specification located at <http://www.microchip.com/packaging>

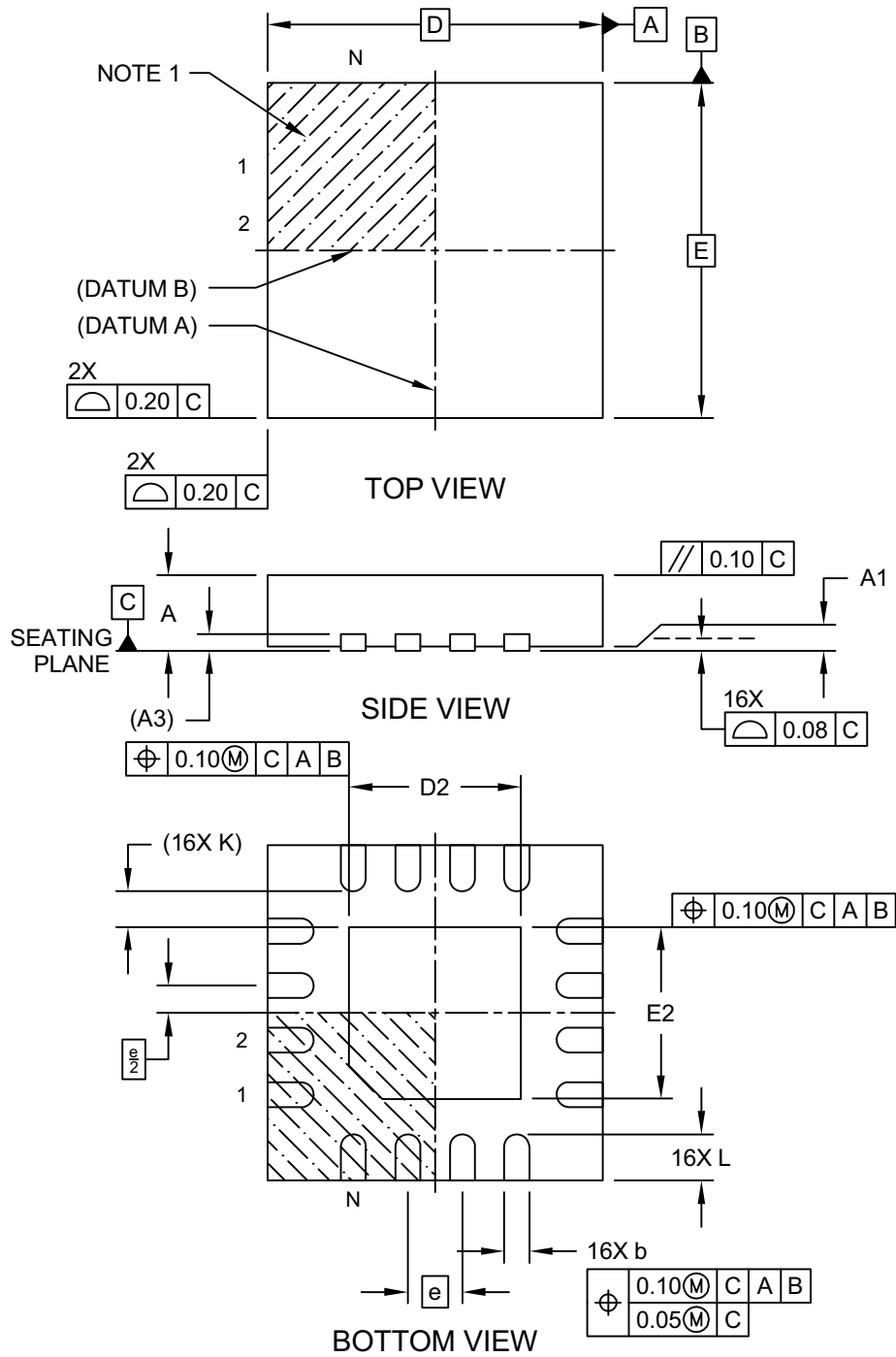

Microchip Technology Drawing C04-259B Sheet 1 of 2

EQCO62T20.3/EQCO31T20.3

16-Lead Plastic Quad Flat, No Lead Package (8E) - 4x4x0.9 mm Body [QFN]

Note: For the most current package drawings, please see the Microchip Packaging Specification located at <http://www.microchip.com/packaging>

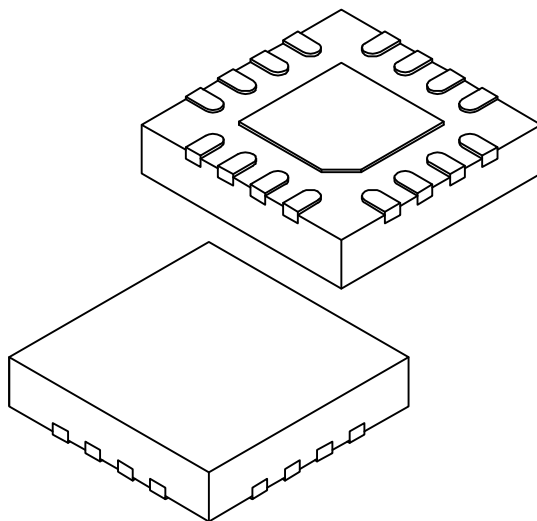

Dimension Limits	Units	MILLIMETERS		
		MIN	NOM	MAX
Number of Pins	N	16		
Pitch	e	0.65 BSC		
Overall Height	A	0.80	0.87	0.95
Standoff	A1	0.00	0.02	0.05
Terminal Thickness	A3	0.20 REF		
Overall Width	E	4.00 BSC		
Exposed Pad Width	E2	1.95	2.05	2.15
Overall Length	D	4.00 BSC		
Exposed Pad Length	D2	1.95	2.05	2.15
Terminal Width	b	0.25	0.30	0.35
Terminal Length	L	0.45	0.55	0.65
Terminal-to-Exposed-Pad	K	0.425 REF		

Notes:

1. Pin 1 visual index feature may vary, but must be located within the hatched area.
2. Package is saw singulated
3. Dimensioning and tolerancing per ASME Y14.5M
BSC: Basic Dimension. Theoretically exact value shown without tolerances.
REF: Reference Dimension, usually without tolerance, for information purposes only.

Microchip Technology Drawing C04-259B Sheet 2 of 2

EQCO62T20.3/EQCO31T20.3

16-Lead Plastic Quad Flat, No Lead Package (8E) - 4x4x0.9 mm Body [QFN]

Note: For the most current package drawings, please see the Microchip Packaging Specification located at <http://www.microchip.com/packaging>

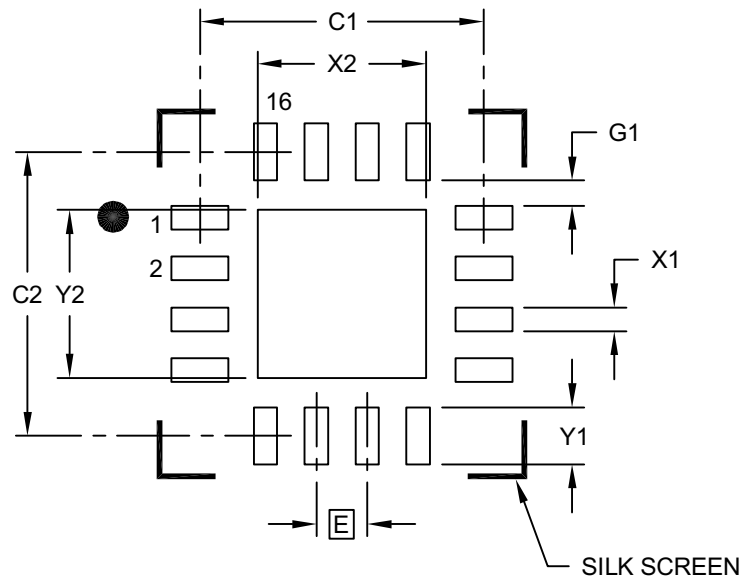

RECOMMENDED LAND PATTERN

Dimension Limits	Units	MILLIMETERS		
		MIN	NOM	MAX
Contact Pitch	E	0.65 BSC		
Optional Center Pad Width	X2			2.15
Optional Center Pad Length	Y2			2.15
Contact Pad Spacing	C1		3.625	
Contact Pad Spacing	C2		3.625	
Contact Pad Width (X16)	X1			0.30
Contact Pad Length (X16)	Y1			0.725
Contact Pad to Center Pad (X16)	G1	0.20		

Notes:

1. Dimensioning and tolerancing per ASME Y14.5M

BSC: Basic Dimension. Theoretically exact value shown without tolerances.

Microchip Technology Drawing C04-2259A

APPENDIX A: REVISION HISTORY

Revision B (March 2016)

- Updated [Section 4.0 “Packaging Information”](#).
- Removed electrostatic discharge ratings from [Table 3-1](#).
- Minor typographical changes.

Revision A (August 2014)

- This is the initial release of the document in the Microchip format. This replaces EqcoLogic document version 1v5.

TABLE A-1: REVISION HISTORY

Version	Date	Comments
1v5	1/27/14	Added references
1v4	4/10/12	Added Multilane CoaXPress 4+1 layout with DIN1.0/2.3 connectors
1v3	10/4/11	Section 5.5 on PoXCXP was added
1v2	9/29/11	C1 and C2 in application circuit of Figure 5 have changed to 33 nF
1v1	8/31/11	Quality review
1v0	8/30/11	Initial release of this document

EQCO62T20.3/EQCO31T20.3

APPENDIX B: TYPICAL LINE DRIVER CHARACTERISTICS

All measurements at VCC = 1.2V, Temp = +25°C, data pattern = PRBS7, 2x300 mV input amplitude.

Note: The imperfections in the output eye are caused by the limited bandwidth of the 75Ω to 50Ω matching pad that was used in this setup. The output amplitude is reduced due to this matching pad.

FIGURE B-1: 1.25 GBPS

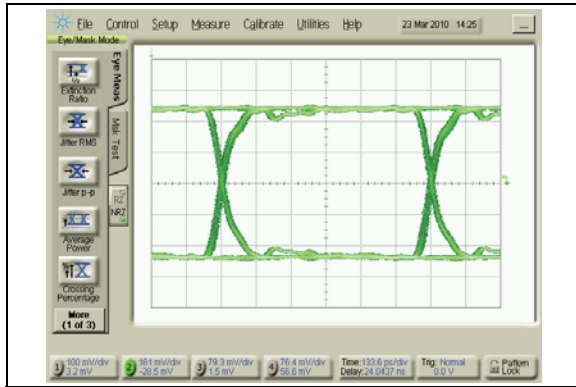

FIGURE B-4: 2.5 GBPS

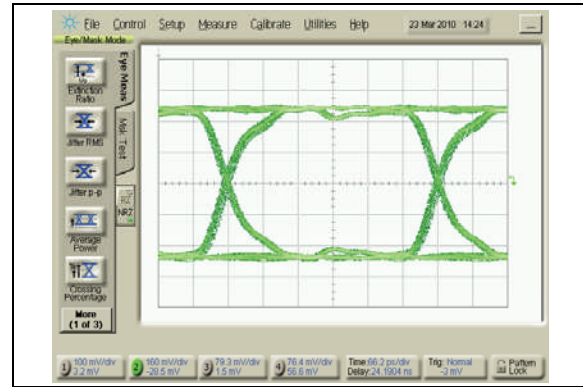

FIGURE B-2: 3.125 GBPS

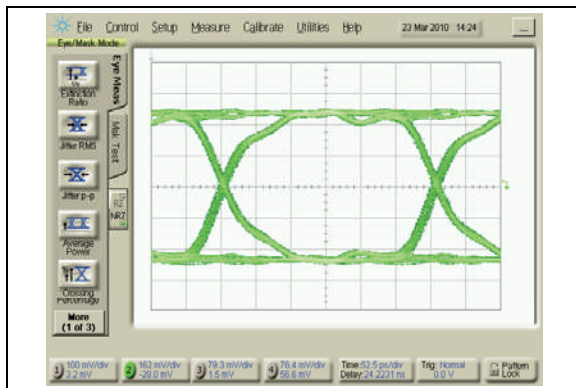

FIGURE B-5: 5 GBPS (EQCO62T20 ONLY)

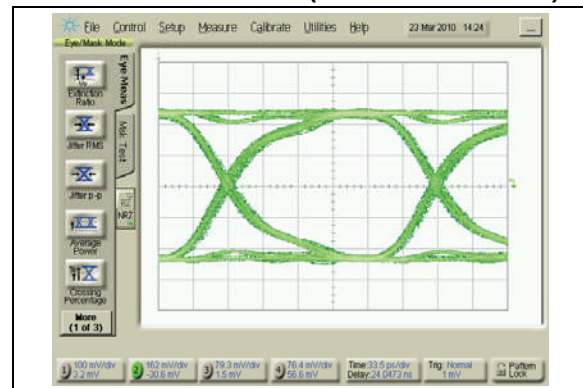
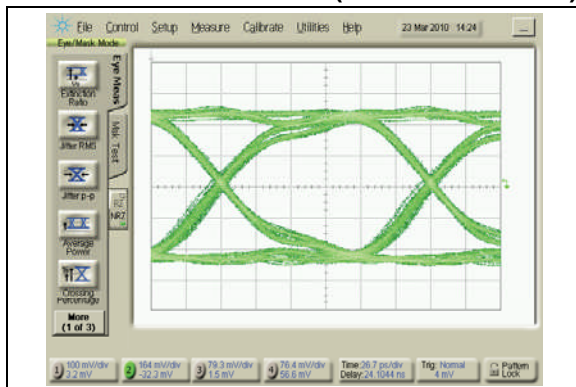

FIGURE B-3: 6.25 GBPS (EQCO62T20 ONLY)



EQCO62T20.3/EQCO31T20.3

APPENDIX C: TYPICAL UPLINK CHARACTERISTICS

All measurements at VCC = 1.2V, Temp = +25°C, data pattern = 8B/10B test pattern at 21 Mbps, 110 mV transmit amplitude using Belden 1694A coaxial cable. Measurements include power supply transmission; EQCO62T20 is powered over the cable. Measured into 15 pF capacitive load.

FIGURE C-1: 0M, NO DOWNLINK SIGNAL

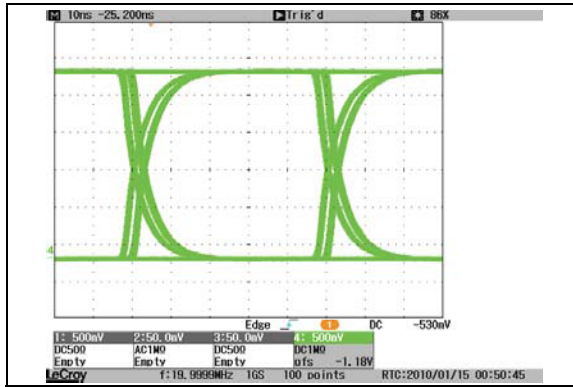

FIGURE C-3: 130M, NO DOWNLINK SIGNAL

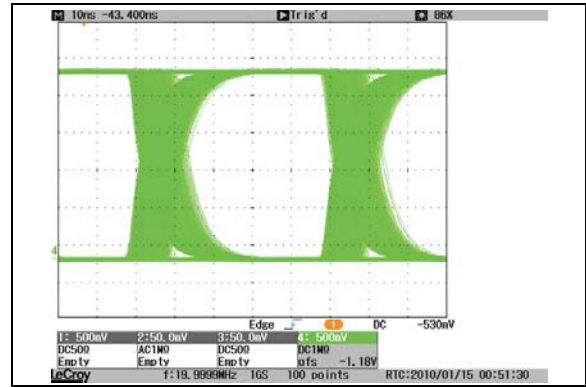

FIGURE C-2: 0M, DOWNLINK SIGNAL = 1.25 GBPS, 8B/10B CODED SIGNAL

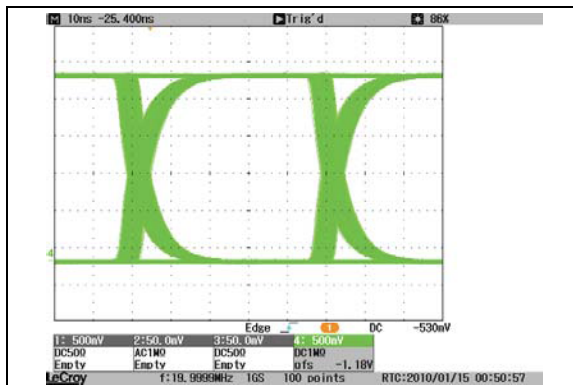
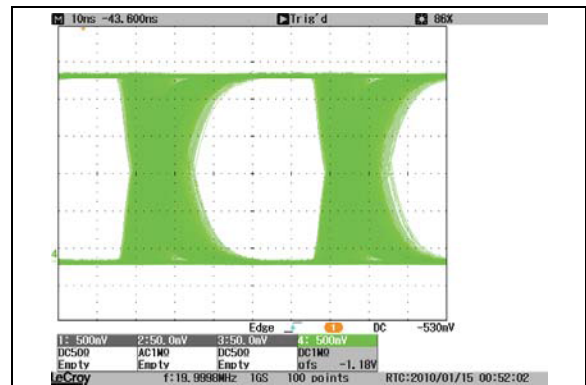

FIGURE C-4: 130M, DOWNLINK SIGNAL = 1.25 GBPS, 8B/10B CODED SIGNAL



EQCO62T20.3/EQCO31T20.3

APPENDIX D: TYPICAL RETURN-LOSS

Figure D-1 shows the return-loss at the BNC connector of the EQCO62T20.3 evaluation board as shown in [Section 2.0 “Application Information”](#) and [Section 2.1 “Guidelines for PCB Layout”](#) with a supply current of 0 mA and 703 mA (maximum supply current for CoaXPress) through the inductor (L1) and the ferrite beads (Fb1 & Fb2) and compares it with the CoaXPress (Full-Speed) return-loss specification.

FIGURE D-1: RETURN-LOSS OF THE EQCO62T20.3 BNC EVALUATION BOARD WITH AND WITHOUT SUPPLY CURRENT

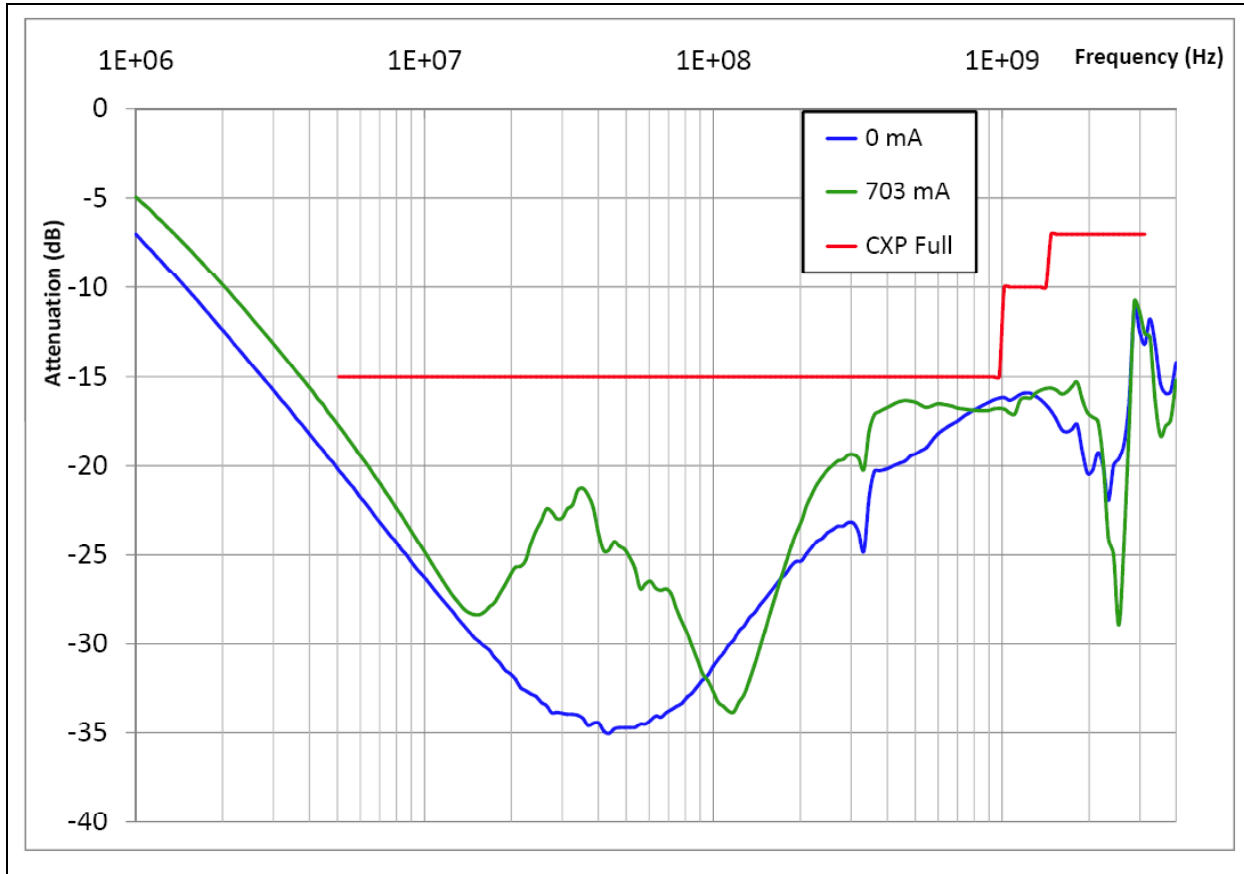

EQCO62T20.3/EQCO31T20.3

APPENDIX E: FOOTPRINTS USED FOR THE MULTILANE COAXPRESS LAYOUT

FIGURE E-1: 0402, 0603 AND VIA WITH THERMAL ISOLATION FOOTPRINTS

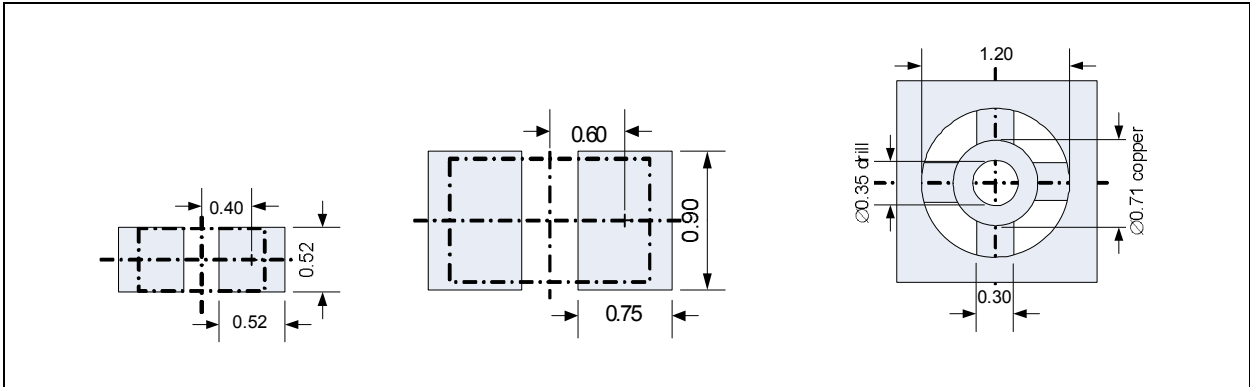

FIGURE E-2: DIN1.0/2.3 AND L1 INDUCTOR 1812 FOOTPRINTS

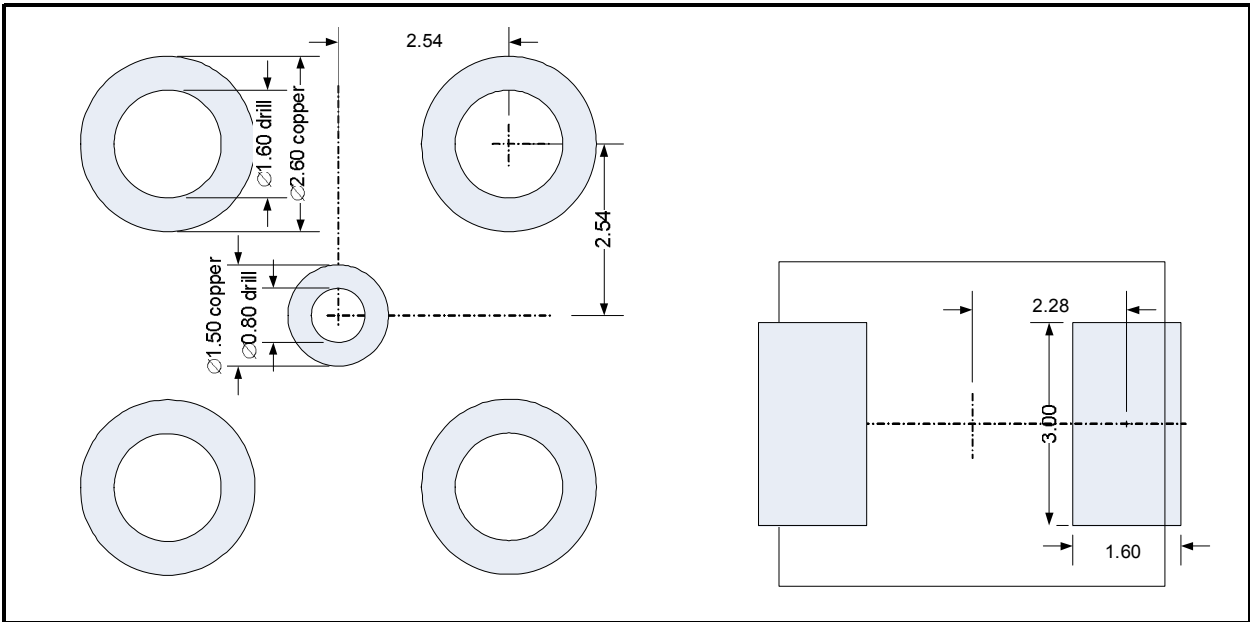

TABLE E-1: COMPONENT POSITIONS OF [Figure 2-4](#)

Component	Footprint	X	Y	Angle	
NPF 4076	DIN1.0/2.3	0	0	—	Bottom
EQCO62T20.3	QFN	0	-7.4	—	
C1 (50V)	0603	-0.325	-2.4	90°	
C2	0402	0.675	-2	90°	
R1	0402	0.675	-3.6	90°	
FB1	0603	-2.025	0.6	—	
FB2	0603	-2.025	-0.6	—	
R3	0402	-4.025	0.3	—	
C6 (50V)	0402	-4.5	1.675	90°	
C9	0402	-1.975	-4.4	—	
C10	0402	1.875	-4.4	—	
C8	0402	-3.325	-10.35	90°	

EQCO62T20.3/EQCO31T20.3

Component	Footprint	X	Y	Angle	
L1	1812	-4.5	-7.875	90°	Bottom
C7 (50V)	0603	-1.6	-7.325	90°	Bottom
C5	0402	0	-9.825	90°	Bottom

TABLE E-2: VIA POSITIONS OF Figure 2-4

VIA	Thermal	X	Y	Connected To
1		-4.9	-4.4	Top-Bottom
2		-4.1	-4.4	Top-Bottom
3	Not isolated	-1.575	-5.15	Top-Power
4	Not isolated	1.575	-5.15	Top-Power
5	Not isolated	-2.325	-5.575	Top-GND-Bottom
6	Not isolated	2.275	-5.65	Top-GND-Bottom
7	Isolated	-1.575	-9.375	Top-GND-Bottom
8	Isolated	1.575	-9.375	Top-GND-Bottom
9	Isolated	-0.95	-10.35	Power-Bottom
10	Isolated	0.95	-10.35	Power-Bottom

TABLE E-3: GROUND AND VCC PLANE POSITION OF Figure 2-4

GND Plane Coordinates	X	Y	VCC Plane Coordinates	X	Y
A	-3.15	-9.4	U	-2.475	-9.45
B	-2.475	-8.725	V	-2.475	-5.225
C	-2.475	-6.225	W	-0.8	-5.225
D	-2.775	-5.925	X	-0.8	-6.3
E	-2.775	-2.525	Y	0.8	-6.3
F	-1.25	-2.525	Z	0.8	-5.225
G	-1.25	-3.175	Â	2.475	-5.225
H	0.675	-3.75	Ê	2.475	-9.45
I	0.675	-6.3			
J	0.8	-6.3			
K	0.8	-4.9			
L	1.525	-4.175			
M	1.525	-2.525			
N	2.375	-2.525			
O	2.375	-5.7			
P	2.475	-5.7			
Q	2.475	-8.725			
R	3.15	-9.4			
S	-0.8	-8.5	Î	-0.8	-8.5
T	0.8	-10.05	Ï	0.8	-10.35

EQCO62T20.3/EQCO31T20.3

FIGURE E-3: TRACK DIMENSIONS OF Figure 2-4

Track	Width	
1	0.3	QFN.1; QFN.4 (GND)
2	100Ω diff ⁽¹⁾	QFN.2-3 (SDIp-SDIn)
3	0.3	QFN.9;QFN.12 (VCC)
4	0.2	QFN.10 (SDOn)
5	0.3	QFN.11 (SDOp)
6	0.2	QFN.12 (LFVCC)
7	0.2	QFN.13 (LFO)
8	0.4/0.2	QFN.TAB to C9,C10
9	0.5	C9,C10 to DIN1.0/2.3
10	0.5	C9,C10 to V3,4
11	0.4	C1 to DIN1.0/2.3
12	0.4	C2
13	0.4/0.7	FB
14	0.2	C6
15	0.5	Bottom Tracks

Note 1: Width and spaces between lines needs to be calculated based on PCB layer stack. Impedance should be 100Ω differential.

TABLE E-4: COMPONENT POSITIONS OF Figure 2-5

Component	Footprint	X	Y	Angle	
NPF 4076	DIN1.0/2.3	0	0	—	Bottom
EQCO62T20.3	QFN	0	-6.375	—	
C1 (50V)	0603	-0.525	-2.125	90°	
C2	0402	1.6	-0.05	90°	
R1	0402	0.675	-2.375	90°	
C9	0402	-3	-4.85	90°	
C10	0402	3	-4.85	90°	
C8	0402	-3.45	-7.55	90°	
C5	0402	0	-6.775	90°	Bottom

TABLE E-5: VIA POSITIONS OF Figure 2-5

VIA	Thermal	X	Y	Connected To
3	Not isolated	-1.6	-4.325	Top-Power
4	Not isolated	1.6	-4.325	Top-Power
5	Isolated	-3.675	-5.25	Top-GND-Bottom
6	Isolated	3	-6.025	Top-GND-Bottom
7	Isolated	-1.5	-8.025	Top-GND-Bottom
8	Isolated	1.5	-8.025	Top-GND-Bottom

EQCO62T20.3/EQCO31T20.3

TABLE E-6: GROUND PLANE POSITION OF Figure 2-5

GND Plane Coordinates	X	Y	VCC Plane Coordinates	X	Y
a	-1.15	-3.1	h	-1.15	-3.95
b	-1.15	-5.3	i	-1.15	-5.3
c	1.15	-5.3	j	1.15	-5.3
d	1.15	-3.1	k	1.15	-3.95
e	4.225	-3.1	l	3.925	-3.95
f	-0.8	-7.475	m	-0.8	-7.475
g	0.8	-9.025	n	0.8	-9.325

FIGURE E-4: TRACK WIDTHS OF Figure 2-5

Track	Width	
1	0.3	QFN.1; QFN.4 (GND)
2	100Ω diff.	QFN.2-3 (SDIp-SDIn)
3	0.3	QFN.9; QFN.12 (VCC)
4	0.2	QFN.10 (SDOn)
5	0.3	QFN.11 (SDOp)
6	0.2	QFN.12 (LFVCC)
7	0.2	QFN.13 (LFO)
8	0.2	QFN.TAB to C9,C10
9	0.4	C9,C10 to V3,4
10	0.5	C9,C10 to V5,6
11	0.4	C1 to DIN1.0/2.3
12	0.4	C2
13	0.5	Bottom tracks

FIGURE E-5: USED LAYER STACK

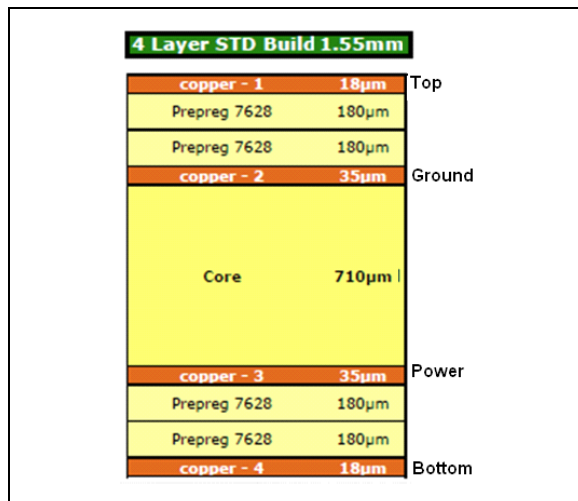

THE MICROCHIP WEB SITE

Microchip provides online support via our web site at [□](#) This web site is used as a means to make files and information easily available to customers. Accessible by using your favorite Internet browser, the web site contains the following information:

- **Product Support** – Data sheets and errata, application notes and sample programs, design resources, user's guides and hardware support documents, latest software releases and archived software
- **General Technical Support** – Frequently Asked Questions (FAQs), technical support requests, online discussion groups, Microchip consultant program member listing
- **Business of Microchip** – Product selector and ordering guides, latest Microchip press releases, listing of seminars and events, listings of Microchip sales offices, distributors and factory representatives

CUSTOMER CHANGE NOTIFICATION SERVICE

Microchip's customer notification service helps keep customers current on Microchip products. Subscribers will receive e-mail notification whenever there are changes, updates, revisions or errata related to a specified product family or development tool of interest.

To register, access the Microchip web site at [□](#) Under "Support", click on "Customer Change Notification" and follow the registration instructions.

CUSTOMER SUPPORT

Users of Microchip products can receive assistance through several channels:

- Distributor or Representative
- Local Sales Office
- Field Application Engineer (FAE)
- Technical Support

Customers should contact their distributor, representative or field application engineer (FAE) for support. Local sales offices are also available to help customers. A listing of sales offices and locations is included in the back of this document.

Technical support is available through the web site at:

EQCO62T20.3/EQCO31T20.3

PRODUCT IDENTIFICATION SYSTEM

To order parts, including industrial, or obtain information, for e.g., on pricing or delivery, refer to the factory or the listed sales office.

<u>PART NO.</u>	<u>I</u>	<u>RM</u>	<u>XXX</u>	
Device	Temp. Range	Radio Module	Firmware Revision Number	
Device: EQCO62T20.3				Examples: a) EQCO62T20.3 = Industrial temperature, 16-Lead QFN Tube packaging b) EQCO62T20.3-TRAY = Industrial temperature, 16-Lead QFN Tray packaging
Temperature Range: I = -40°C to +85°C (Industrial temperature)				
Package: TRAY = Tray (Blank) = Tube				

Note the following details of the code protection feature on Microchip devices:

- Microchip products meet the specification contained in their particular Microchip Data Sheet.
- Microchip believes that its family of products is one of the most secure families of its kind on the market today, when used in the intended manner and under normal conditions.
- There are dishonest and possibly illegal methods used to breach the code protection feature. All of these methods, to our knowledge, require using the Microchip products in a manner outside the operating specifications contained in Microchip's Data Sheets. Most likely, the person doing so is engaged in theft of intellectual property.
- Microchip is willing to work with the customer who is concerned about the integrity of their code.
- Neither Microchip nor any other semiconductor manufacturer can guarantee the security of their code. Code protection does not mean that we are guaranteeing the product as “unbreakable.”

Code protection is constantly evolving. We at Microchip are committed to continuously improving the code protection features of our products. Attempts to break Microchip's code protection feature may be a violation of the Digital Millennium Copyright Act. If such acts allow unauthorized access to your software or other copyrighted work, you may have a right to sue for relief under that Act.

Information contained in this publication regarding device applications and the like is provided only for your convenience and may be superseded by updates. It is your responsibility to ensure that your application meets with your specifications. MICROCHIP MAKES NO REPRESENTATIONS OR WARRANTIES OF ANY KIND WHETHER EXPRESS OR IMPLIED, WRITTEN OR ORAL, STATUTORY OR OTHERWISE, RELATED TO THE INFORMATION, INCLUDING BUT NOT LIMITED TO ITS CONDITION, QUALITY, PERFORMANCE, MERCHANTABILITY OR FITNESS FOR PURPOSE. Microchip disclaims all liability arising from this information and its use. Use of Microchip devices in life support and/or safety applications is entirely at the buyer's risk, and the buyer agrees to defend, indemnify and hold harmless Microchip from any and all damages, claims, suits, or expenses resulting from such use. No licenses are conveyed, implicitly or otherwise, under any Microchip intellectual property rights unless otherwise stated.

Microchip received ISO/TS-16949:2009 certification for its worldwide headquarters, design and wafer fabrication facilities in Chandler and Tempe, Arizona; Gresham, Oregon and design centers in California and India. The Company's quality system processes and procedures are for its PIC[®] MCUs and dsPIC[®] DSCs, KEELoQ[®] code hopping devices, Serial EEPROMs, microperipherals, nonvolatile memory and analog products. In addition, Microchip's quality system for the design and manufacture of development systems is ISO 9001:2000 certified.

**QUALITY MANAGEMENT SYSTEM
CERTIFIED BY DNV
= ISO/TS 16949 =**

Trademarks

The Microchip name and logo, the Microchip logo, AnyRate, dsPIC, FlashFlex, flexPWR, Heldo, JukeBlox, KeeLoq, KeeLoq logo, Klear, LANCheck, LINK MD, MediaLB, MOST, MOST logo, MPLAB, OptoLyzer, PIC, PICSTART, PIC32 logo, RightTouch, SpyNIC, SST, SST Logo, SuperFlash and UNI/O are registered trademarks of Microchip Technology Incorporated in the U.S.A. and other countries.

ClockWorks, The Embedded Control Solutions Company, ETHERSYNCH, Hyper Speed Control, HyperLight Load, IntelliMOS, mTouch, Precision Edge, and QUIET-WIRE are registered trademarks of Microchip Technology Incorporated in the U.S.A.

Analog-for-the-Digital Age, Any Capacitor, AnyIn, AnyOut, BodyCom, chipKIT, chipKIT logo, CodeGuard, dsPICDEM, dsPICDEM.net, Dynamic Average Matching, DAM, ECAN, EtherGREEN, In-Circuit Serial Programming, ICSP, Inter-Chip Connectivity, JitterBlocker, KlearNet, KlearNet logo, MiWi, motorBench, MPASM, MPF, MPLAB Certified logo, MPLIB, MPLINK, MultiTRAK, NetDetach, Omniscient Code Generation, PICDEM, PICDEM.net, PICkit, PICtail, PureSilicon, RightTouch logo, REAL ICE, Ripple Blocker, Serial Quad I/O, SQL, SuperSwitcher, SuperSwitcher II, Total Endurance, TSHARC, USBCheck, VariSense, ViewSpan, WiperLock, Wireless DNA, and ZENA are trademarks of Microchip Technology Incorporated in the U.S.A. and other countries.

SQTP is a service mark of Microchip Technology Incorporated in the U.S.A.

Silicon Storage Technology is a registered trademark of Microchip Technology Inc. in other countries.

GestIC is a registered trademarks of Microchip Technology Germany II GmbH & Co. KG, a subsidiary of Microchip Technology Inc., in other countries.

All other trademarks mentioned herein are property of their respective companies.

© 2011-2016, Microchip Technology Incorporated, Printed in the U.S.A., All Rights Reserved.

ISBN: 978-1-5224-0371-5



MICROCHIP

Worldwide Sales and Service

AMERICAS

Corporate Office

2355 West Chandler Blvd.
Chandler, AZ 85224-6199
Tel: 480-792-7200
Fax: 480-792-7277
Technical Support:

Web Address:



Atlanta

Duluth, GA
Tel: 678-957-9614
Fax: 678-957-1455

Austin, TX

Tel: 512-257-3370

Boston

Westborough, MA
Tel: 774-760-0087
Fax: 774-760-0088

Chicago

Itasca, IL
Tel: 630-285-0071
Fax: 630-285-0075
Cleveland Independence, OH
Tel: 216-447-0464
Fax: 216-447-0643

Dallas

Addison, TX
Tel: 972-818-7423
Fax: 972-818-2924

Detroit

Novi, MI
Tel: 248-848-4000

Houston, TX

Tel: 281-894-5983
Indianapolis Noblesville, IN
Tel: 317-773-8323
Fax: 317-773-5453

Los Angeles

Mission Viejo, CA
Tel: 949-462-9523
Fax: 949-462-9608

New York, NY

Tel: 631-435-6000

San Jose, CA

Tel: 408-735-9110

Canada - Toronto

Tel: 905-673-0699
Fax: 905-673-6509

ASIA/PACIFIC

Asia Pacific Office

Suites 3707-14, 37th Floor
Tower 6, The Gateway
Harbour City, Kowloon

Hong Kong

Tel: 852-2943-5100
Fax: 852-2401-3431

Australia - Sydney

Tel: 61-2-9868-6733
Fax: 61-2-9868-6755

China - Beijing

Tel: 86-10-8569-7000
Fax: 86-10-8528-2104

China - Chengdu

Tel: 86-28-8665-5511
Fax: 86-28-8665-7889

China - Chongqing

Tel: 86-23-8980-9588
Fax: 86-23-8980-9500

China - Dongguan

Tel: 86-769-8702-9880

China - Hangzhou

Tel: 86-571-8792-8115
Fax: 86-571-8792-8116

China - Hong Kong SAR

Tel: 852-2943-5100
Fax: 852-2401-3431

China - Nanjing

Tel: 86-25-8473-2460
Fax: 86-25-8473-2470

China - Qingdao

Tel: 86-532-8502-7355
Fax: 86-532-8502-7205

China - Shanghai

Tel: 86-21-5407-5533
Fax: 86-21-5407-5066

China - Shenyang

Tel: 86-24-2334-2829
Fax: 86-24-2334-2393

China - Shenzhen

Tel: 86-755-8864-2200
Fax: 86-755-8203-1760

China - Wuhan

Tel: 86-27-5980-5300
Fax: 86-27-5980-5118

China - Xian

Tel: 86-29-8833-7252
Fax: 86-29-8833-7256

ASIA/PACIFIC

China - Xiamen

Tel: 86-592-2388138
Fax: 86-592-2388130

China - Zhuhai

Tel: 86-756-3210040
Fax: 86-756-3210049

India - Bangalore

Tel: 91-80-3090-4444
Fax: 91-80-3090-4123

India - New Delhi

Tel: 91-11-4160-8631
Fax: 91-11-4160-8632

India - Pune

Tel: 91-20-3019-1500

Japan - Osaka

Tel: 81-6-6152-7160
Fax: 81-6-6152-9310

Japan - Tokyo

Tel: 81-3-6880-3770
Fax: 81-3-6880-3771

Korea - Daegu

Tel: 82-53-744-4301
Fax: 82-53-744-4302

Korea - Seoul

Tel: 82-2-554-7200
Fax: 82-2-558-5932 or
82-2-558-5934

Malaysia - Kuala Lumpur

Tel: 60-3-6201-9857
Fax: 60-3-6201-9859

Malaysia - Penang

Tel: 60-4-227-8870
Fax: 60-4-227-4068

Philippines - Manila

Tel: 63-2-634-9065
Fax: 63-2-634-9069

Singapore

Tel: 65-6334-8870
Fax: 65-6334-8850

Taiwan - Hsin Chu

Tel: 886-3-5778-366
Fax: 886-3-5770-955

Taiwan - Kaohsiung

Tel: 886-7-213-7828

Taiwan - Taipei

Tel: 886-2-2508-8600
Fax: 886-2-2508-0102

Thailand - Bangkok

Tel: 66-2-694-1351
Fax: 66-2-694-1350

EUROPE

Austria - Wels

Tel: 43-7242-2244-39
Fax: 43-7242-2244-393

Denmark - Copenhagen

Tel: 45-4450-2828
Fax: 45-4485-2829

France - Paris

Tel: 33-1-69-53-63-20
Fax: 33-1-69-30-90-79

Germany - Dusseldorf

Tel: 49-2129-3766400

Germany - Karlsruhe

Tel: 49-721-625370

Germany - Munich

Tel: 49-89-627-144-0
Fax: 49-89-627-144-44

Italy - Milan

Tel: 39-0331-742611
Fax: 39-0331-466781

Italy - Venice

Tel: 39-049-7625286

Netherlands - Drunen

Tel: 31-416-690399
Fax: 31-416-690340

Poland - Warsaw

Tel: 48-22-3325737

Spain - Madrid

Tel: 34-91-708-08-90
Fax: 34-91-708-08-91

Sweden - Stockholm

Tel: 46-8-5090-4654

UK - Wokingham

Tel: 44-118-921-5800
Fax: 44-118-921-5820

07/14/15