

24 Austin Lynx™: Non-Isolated DC-DC Power Modules

20Vdc – 30Vdc input; 5.0 Vdc to 15 Vdc output; 70W Output Power

RoHS Compliant



Applications

- Distributed power architectures
- Intermediate bus voltage applications
- Telecommunications equipment
- Wireless Base stations
- Industrial equipment
- LANs/WANs
- Enterprise Networks
- Latest generation IC's (DSP, FPGA, ASIC) and Microprocessor powered applications

Description

The Austin Lynx™ 24V series SIP power module is a non-isolated DC-DC converter in an industry standard package that can deliver up to 70W of output power with a full load efficiency of 97% at 12Vdc output voltage ($V_{IN} = 24Vdc$). The module operates over a wide input voltage range ($V_{IN} = 20 - 30Vdc$) and provides a precisely regulated output voltage from 5 to 15Vdc, programmable via an external resistor. Standard features include remote On/Off, adjustable output voltage, remote sense, over current and over temperature protection.

* UL is a registered trademark of Underwriters Laboratories, Inc.

† CSA is a registered trademark of Canadian Standards Association.

‡ VDE is a trademark of Verband Deutscher Elektrotechniker e.V.

** ISO is a registered trademark of the International Organization of Standards

Features

- Compliant to RoHS EU Directive 2002/95/EC (-Z versions)
- Compliant to ROHS EU Directive 2002/95/EC with lead solder exemption (non-Z versions)
- Wide input voltage range: 20 to 30Vdc
- Output voltage programmable via external resistor: 5Vdc to 15Vdc
- High efficiency modules ($V_{IN} = 24Vdc$) 97% at 12Vdc full load
- Low output ripple and noise
- Monotonic start-up into pre-bias output
- Remote On/Off (Positive logic)
- Remote Sense
- Small size and low profile: 50.8 mm x 12.7 mm x 8.1 mm (2.00 in x 0.50 in x 0.32 in)
- Constant switching frequency
- Wide operating temperature range (-40°C to 85°C)
- Over current and Over temperature protection (non-latching)
- UL* 60950-1 Recognized, CSA† C22.2 No. 60950-1-03 Certified, and VDE‡ 0805:2001-12 (EN60950-1) Licensed
- ISO** 9001 and ISO 14001 certified manufacturing facilities

24V Austin Lynx™: Non-Isolated DC-DC Power Modules

20Vdc –30Vdc input; 5Vdc to 15Vdc output; 70W Output Power

Absolute Maximum Ratings

Stresses in excess of the absolute maximum ratings can cause permanent damage to the device. These are absolute stress ratings only, functional operation of the device is not implied at these or any other conditions in excess of those given in the operations sections of the data sheet. Exposure to absolute maximum ratings for extended periods can adversely affect the device reliability.

Parameter	Device	Symbol	Min	Max	Unit
Input Voltage Continuous	All	V_{IN}	-0.3	36	Vdc
Operating Ambient Temperature (see Thermal Considerations section)	All	T_A	-40	85	°C
Storage Temperature	All	T_{stg}	-55	125	°C

Electrical Specifications

Unless otherwise indicated, specifications apply over all operating input voltage, resistive load, and temperature conditions.

Parameter	Device	Symbol	Min	Typ	Max	Unit
Operating Input Voltage	All	V_{IN}	20.0	24.0	30.0	Vdc
Maximum Input Current ($V_{IN}=20V$, $V_O=12V$, $I_O=6A$)	All	$I_{IN,max}$			4.5	Adc
Input No Load Current ($V_{IN}=24Vdc$, $I_O=0$, module enabled)	$V_O=5.0Vdc$ $V_O=12Vdc$	$I_{IN,No Load}$ $I_{IN,No Load}$		60 120		mAdc mAdc
Input Stand-by Current ($V_{IN}=24Vdc$, module disabled)	$V_O=5.0Vdc$ $V_O=12Vdc$	$I_{IN,stand-by}$ $I_{IN,stand-by}$			3 3	mA mA
Inrush Transient	All	I^2t			1	A ² s
Input Reflected Ripple Current, peak-to-peak (5Hz to 20MHz, 1 μ H source impedance; $V_{IN}=20V$ to 30V, $I_O=I_{O,max}$; See Figure 25)	All			50		mAp-p
Input Ripple Rejection (120Hz)	All		50			dB

CAUTION: These power modules can be used in a wide variety of applications ranging from simple standalone operation to an integrated part of sophisticated power architectures. To preserve maximum flexibility, no internal fuse has been provided. Also, extensive safety testing has shown that no external fuse is required to protect the unit. However, it is still recommended that some type of current-limiting power source be used to protect the module and evaluated in the end-use equipment.

24V Austin Lynx™: Non-Isolated DC-DC Power Modules

20Vdc –30Vdc input; 5Vdc to 15Vdc output; 70W Output Power

Electrical Specifications (continued)

Parameter	Device	Symbol	Min	Typ	Max	Unit
Output Voltage Set-point ($V_{IN}=V_{N,min}$, $I_O=I_{O,max}$, $T_A=25^\circ\text{C}$)	All	$V_{O,set}$	-2.0	$V_{O,set}$	+2.0	% $V_{O,set}$
Output Voltage (Over all operating input voltage, resistive load, and temperature conditions until end of life)	All	$V_{O,set}$	-3%	—	+3%	% $V_{O,set}$
Adjustment Range Selected by an external resistor	All	V_O	5.0		15.0	Vdc
Output Regulation Line ($V_{IN}=V_{IN,min}$ to $V_{IN,max}$) Load ($I_O=I_{O,min}$ to $I_{O,max}$) Temperature ($T_{ref}=T_{A,min}$ to $T_{A,max}$)	All All All		— — —	— — 0.5	0.4 0.4 1	% $V_{O,set}$ % $V_{O,set}$ % $V_{O,set}$
Output Ripple and Noise on nominal output ($V_{IN}=V_{IN,nom}$ and $I_O=I_{O,min}$ to $I_{O,max}$ Cout =0.01 μF ceramic//10 μF tantalum capacitors) Peak-to-Peak (5Hz to 20MHz bandwidth)	All		—	100	200	mV _{pk-pk}
External Capacitance ESR $\geq 1\text{ m}\Omega$ ESR $\geq 10\text{ m}\Omega$	All	$C_{O,max}$ $C_{O,max}$	0 0	— —	1,000 2,000	μF μF
Output Current ($V_{IN} = V_{IN,nom}$) $V_O = 5.0\text{Vdc}$ $V_O = 12.0\text{Vdc}$ $V_O = 15.0\text{Vdc}$	All	$I_{O,max}$	0 0 0		10 6 4.5	Adc
Output Power ($V_{IN} = V_{IN,nom}$) $V_O = V_{O,min}$ to $V_{O,max}$	All	P_O			70	W
Output Short-Circuit Current ($V_O \leq 250\text{mV}$) (Hiccup Mode)	All	$I_{O,s/c}$	—	20	—	Adc
Efficiency $V_{IN}=V_{IN,nom}$, $T_A=25^\circ\text{C}$ $I_O=I_{O,max}$, $V_O=V_{O,set}$		η η η		93 97 97		% % %
Switching Frequency (Fixed)	All	f_{sw}	—	300	—	kHz

24V Austin Lynx™: Non-Isolated DC-DC Power Modules

20Vdc –30Vdc input; 5Vdc to 15Vdc output; 70W Output Power

Electrical Specifications (continued)

Parameter	Device	Symbol	Min	Typ	Max	Unit
Dynamic Load Response ($dI_o/dt=5A/\mu s$; $V_{IN}=V_{IN, nom}$; $T_A=25^\circ C$) Load Change from $I_o= 50\%$ to 100% of $I_{o,max}$; No external output capacitors Peak Deviation ($V_o = 12Vdc$) Settling Time ($V_o<10\%$ peak deviation)	All	V_{pk}		220		mV
	All	t_s		50		μs
($dI_o/dt=5A/\mu s$; $V_{IN}=V_{IN, nom}$; $T_A=25^\circ C$) Load Change from $I_o= 100\%$ to 50% of $I_{o,max}$; No external output capacitors Peak Deviation ($V_o = 12Vdc$) Settling Time ($V_o<10\%$ peak deviation)	All	V_{pk}		220		mV
	All	t_s		50		μs
($dI_o/dt=5A/\mu s$; $V_{IN}=V_{IN, nom}$; $T_A=25^\circ C$) Load Change from $I_o= 50\%$ to 100% of $I_{o,max}$; 2x150 μF polymer capacitor Peak Deviation ($V_o = 12Vdc$) Settling Time ($V_o<10\%$ peak deviation)	All	V_{pk}	—	130		mV
	All	t_s	—	50		μs
($dI_o/dt=5A/\mu s$; $V_{IN}=V_{IN, nom}$; $T_A=25^\circ C$) Load Change from $I_o= 100\%$ to 50% of $I_{o,max}$; 2x150 μF polymer capacitor Peak Deviation ($V_o = 12Vdc$) Settling Time ($V_o<10\%$ peak deviation)	All	V_{pk}	—	130		mV
	All	t_s	—	50	—	μs

General Specifications

Parameter	Device	Min	Typ	Max	Unit
Calculated MTBF ($V_{IN}= V_{IN, nom}$, $I_o= 0.8I_{o,max}$, $T_A=40^\circ C$) Telecordia SR 332 Issue 1: Method 1, case 3	All		8,035,510		Hours
Weight		—	6.4 (0.23)	—	g (oz.)

24V Austin Lynx™: Non-Isolated DC-DC Power Modules

20Vdc –30Vdc input; 5Vdc to 15Vdc output; 70W Output Power

Feature Specifications

Unless otherwise indicated, specifications apply over all operating input voltage, resistive load, and temperature conditions. See Feature Descriptions for additional information.

Parameter	Device	Symbol	Min	Typ	Max	Unit
On/Off Signal interface (On/Off is open collector/drain logic input; Signal referenced to GND - See feature description section) Device is with suffix "4" – Positive Logic Logic High (On/Off pin open – Module ON)						
Input High Current	All	I _{IH}		—	10	μA
Input High Voltage	All	V _{IH}	V _{IN} -2.5	—	30	V
Logic Low (Module OFF)						
Input Low Current	All	I _{IL}	—	—	1	mA
Input Low Voltage	All	V _{IL}	-0.3	—	1.2	V
Turn-On Delay and Rise Times (V _{IN} =V _{IN, nom} , I _o =I _{o, max} , V _o to within ±1% of steady state)						
Case 1: On/Off input is enabled and then input power is applied (delay from instant at which V _{IN} = V _{IN, min} until V _o = 10% of V _{o, set})	All	T _{delay}	2	4	8	Msec
Case 2: Input power is applied for at least one second and then the On/Off input is enabled (delay from instant at which V _{on/Off} is enabled until V _o = 10% of V _{o, set})	All	T _{delay}	2	4	8	Msec
Output voltage Rise time (time for V _o to rise from 10% of V _{o, set} to 90% of V _{o, set})	All	T _{rise}	2	5	9	Msec
Output voltage overshoot I _o = I _{o, max} ; V _{IN, min} - V _{IN, max} , T _A = 25 °C					3.0	% V _{o, set}
Remote Sense Range			—	—	0.5	V
Over temperature Protection (See Thermal Consideration section)	All	T _{ref}	—	125	135	°C
Input Undervoltage Lockout						
Turn-on Threshold	All				19	Vdc
Turn-off Threshold	All		17			Vdc

24V Austin Lynx™: Non-Isolated DC-DC Power Modules

20Vdc – 30Vdc input; 5Vdc to 15Vdc output; 70W Output Power

Characteristic Curves

The following figures provide typical characteristics for the AXB070X module at 12V, 6A and 25°C.

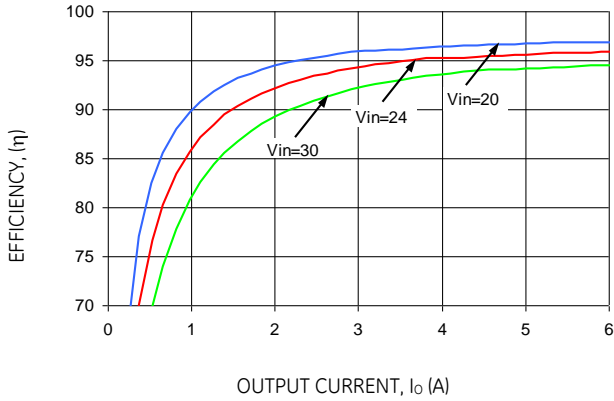

Figure 1. Converter Efficiency versus Output Current ($V_{out} = 12Vdc$).

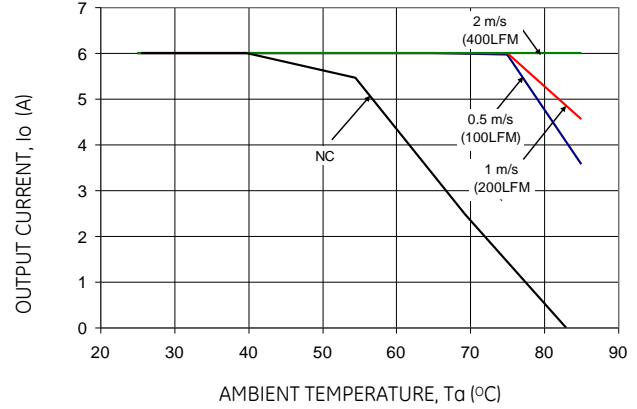

Figure 4. Derating Output Current versus Local Ambient Temperature and Airflow ($V_{in} = 24V$).

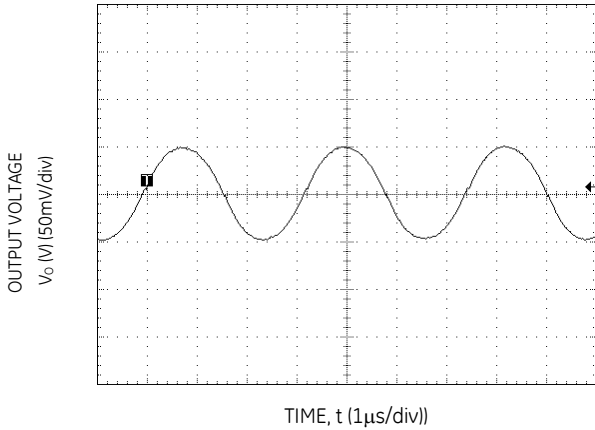

Figure 2. Typical output ripple and noise ($V_{in} = 24V$, $V_o = 12Vdc$, $I_o = 6A$).

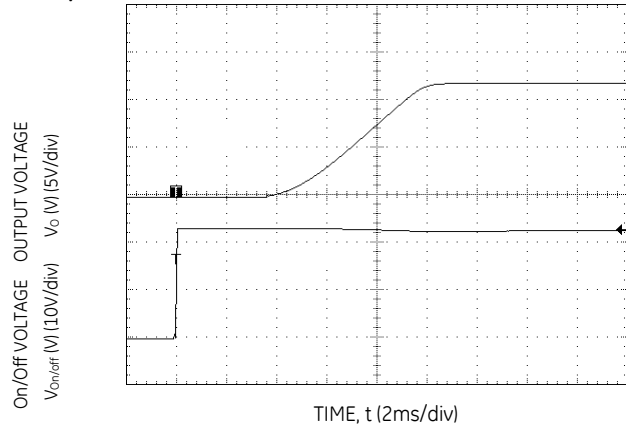

Figure 5. Typical Start-up Using Remote On/Off ($V_{in} = 24V$, $V_o = 12Vdc$, $I_o = 6A$).

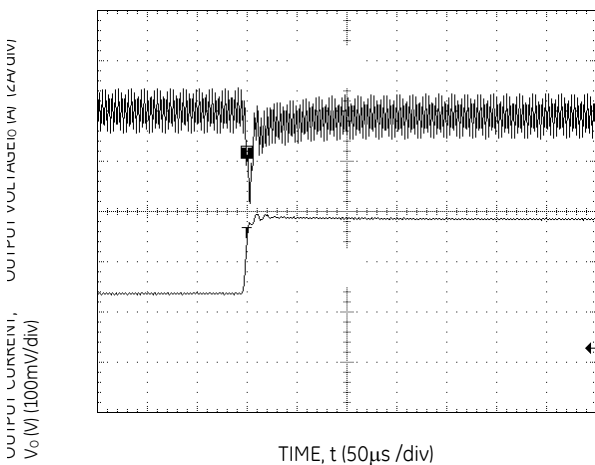

Figure 3. Transient Response to Dynamic Load Change from 50% to 100% with di/dt of 1A/µs.

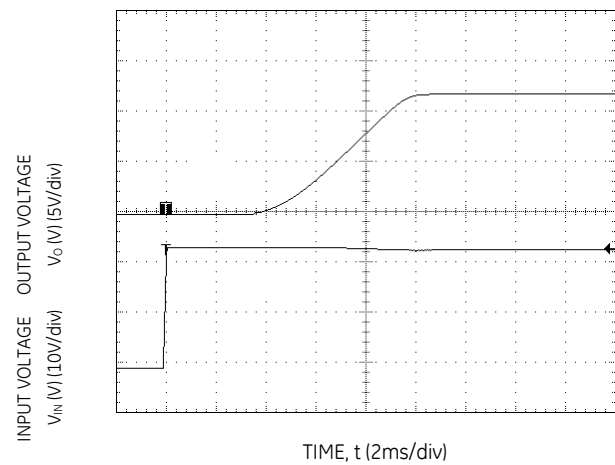

Figure 6. Typical Start-up Using Input Voltage ($V_{in} = 24V$, $I_o = 6A$).

24V Austin Lynx™: Non-Isolated DC-DC Power Modules

20Vdc – 30Vdc input; 5Vdc to 15Vdc output; 70W Output Power

Characteristic Curves (continued)

The following figures provide typical characteristics for the AXB070X module at 5V, 10A and 25°C.

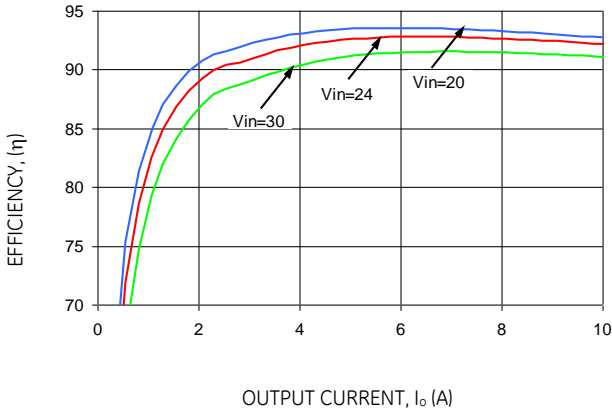

Figure 7. Converter Efficiency versus Output Current.

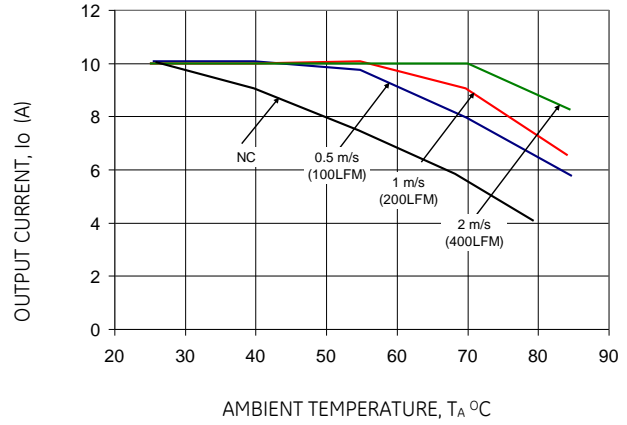

Figure 10. Derating Output Current versus Local Ambient Temperature and Airflow ($V_{IN} = 24V$).

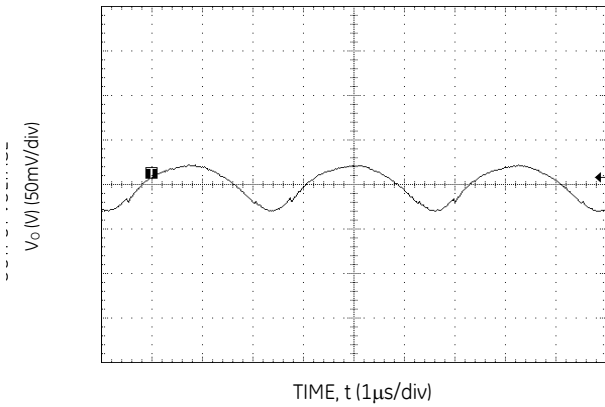

Figure 8. Typical output ripple and noise ($V_{IN} = 24V$, $I_{O} = 10A$).

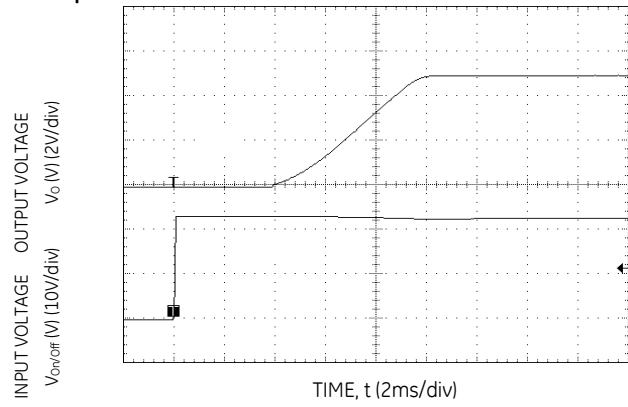

Figure 11. Typical Start-up Using Remote On/Off ($V_{IN} = 24V$, $I_{O} = 10A$).

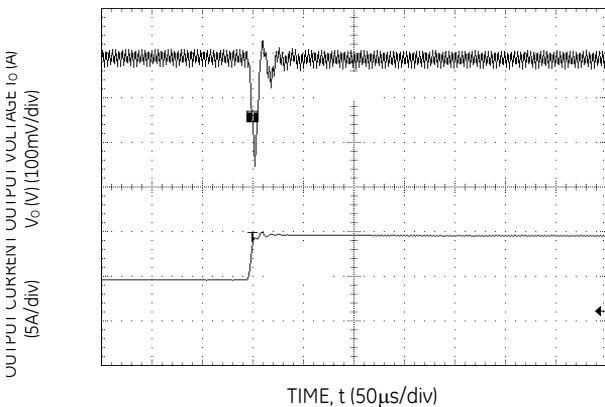

Figure 9. Transient Response to Dynamic Load change from 50% to 100% with di/dt of $1A/\mu s$.

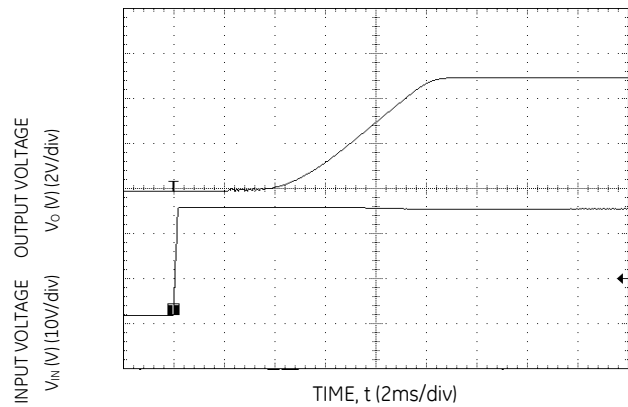
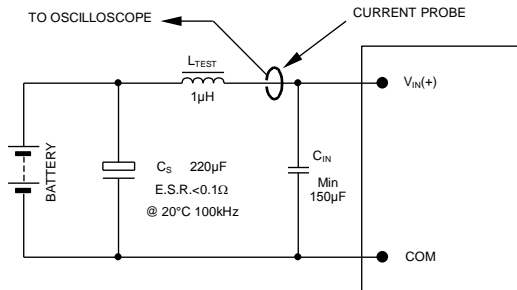

Figure 12. Typical Start-up Using Input Voltage ($V_{IN} = 24V$, $I_{O} = 10A$).

24V Austin Lynx™: Non-Isolated DC-DC Power Modules

20Vdc –30Vdc input; 5Vdc to 15Vdc output; 70W Output Power

Test Configurations



NOTE: Measure input reflected ripple current with a simulated source inductance (L_{TEST}) of 1µH. Capacitor C_S offsets possible battery impedance. Measure current as shown above.

Figure 25. Input Reflected Ripple Current Test Setup.

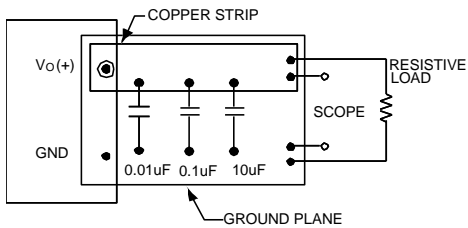

NOTE: All voltage measurements to be taken at the module terminals, as shown above. If sockets are used then Kelvin connections are required at the module terminals to avoid measurement errors due to socket contact resistance.

Figure 26. Output Ripple and Noise Test Setup.

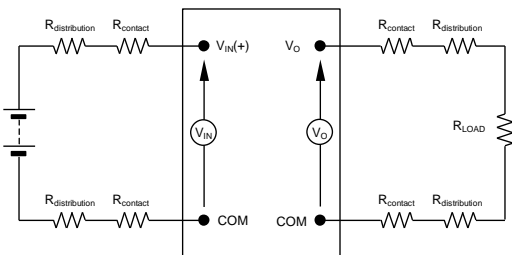

NOTE: All voltage measurements to be taken at the module terminals, as shown above. If sockets are used then Kelvin connections are required at the module terminals to avoid measurement errors due to socket contact resistance.

Figure 27. Output Voltage and Efficiency Test Setup.

$$\text{Efficiency } \eta = \frac{V_O \cdot I_O}{V_{IN} \cdot I_{IN}} \times 100 \%$$

Safety Considerations

For safety agency approval the power module must be installed in compliance with the spacing and separation requirements of the end-use safety agency standards, i.e., UL 60950, CSA C22.2 No. 60950-00, EN60950 (VDE 0850) (IEC60950, 3rd edition) Licensed.

For the converter output to be considered meeting the requirements of safety extra-low voltage (SELV), the input must meet SELV requirements. The power module has extra-low voltage (ELV) outputs when all inputs are ELV.

24V Austin Lynx™: Non-Isolated DC-DC Power Modules

20Vdc –30Vdc input; 5Vdc to 15Vdc output; 70W Output Power

Feature Description

Remote On/Off

The Austin Lynx™ 24V SMT power modules feature an On/Off pin for remote On/Off operation. Positive Logic On/Off signal, device code suffix “4”, turns the module ON during a logic High on the On/Off pin and turns the module OFF during a logic Low.

For positive logic modules, the circuit configuration for using the On/Off pin is shown in Figure 28. The On/Off pin is an open collector/drain logic input signal ($V_{on/off}$) that is referenced to ground. During a logic-high (On/Off pin is pulled high internal to the module) when the transistor Q1 is in the Off state, the power module is ON. Maximum allowable leakage current of the transistor when $V_{on/off} = V_{IN,max}$ is $10\mu A$. Applying a logic-low when the transistor Q1 is turned-On, the power module is OFF. During this state $V_{on/off}$ must be less than 1.2V. When not using positive logic On/off pin, leave the pin unconnected or tie to V_{IN} .

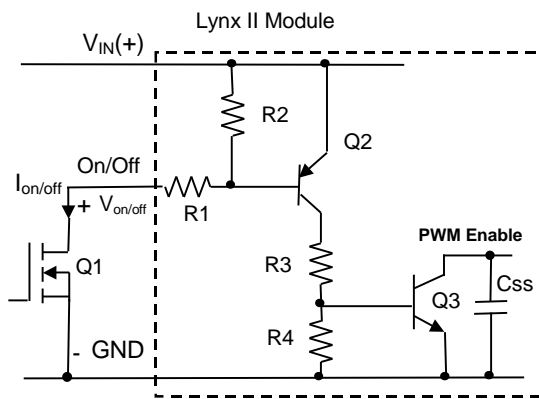

Figure 28. Remote On/Off Implementation circuit.

Remote Sense

The Austin Lynx 24V power modules have a Remote Sense feature to minimize the effects of distribution losses by regulating the voltage at the Remote Sense pin (See Figure 29). The voltage between the Sense pin and V_o pin must not exceed 0.5V.

The amount of power delivered by the module is defined as the output voltage multiplied by the output current ($V_o \times I_o$). When using Remote Sense, the output voltage of the module can increase which increases the power output of the module. Make sure that the maximum output power of the module remains at or below the maximum rated power. When the Remote Sense feature is not being used, connect the Remote Sense pin to the output of the module.

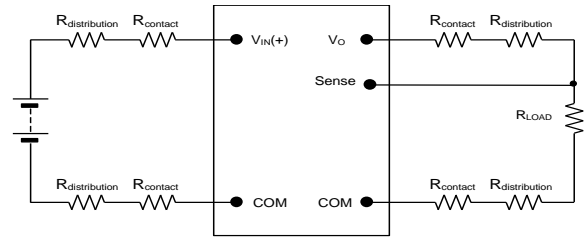

Figure 29. Effective Circuit Configuration for Remote Sense operation.

Overcurrent Protection

To provide protection in a fault (output overload) condition, the unit is equipped with internal current-limiting circuitry and can endure current limiting continuously. At the point of current-limit inception, the unit enters hiccup mode. The unit operates normally once the output current is brought back into its specified range. The average output current during hiccup is $20\% I_{o,max}$.

Input Undervoltage Lockout

At input voltages below the input undervoltage lockout limit, the module operation is disabled. The module will begin to operate at an input voltage above the undervoltage lockout turn-on threshold.

Overtemperature Protection

To provide protection in a fault condition, the unit is equipped with a thermal shutdown circuit. The unit will shutdown if the overtemperature threshold of $130^{\circ}C$ is exceeded at the thermal reference point T_{ref} . The thermal shutdown is not intended as a guarantee that the unit will survive temperatures beyond its rating. Once the unit goes into thermal shutdown it will then wait to cool before attempting to restart.

Output Voltage Programming

The output voltage of the Austin Lynx 24V can be programmed to any voltage in the specified ranges by connecting a resistor (shown as R_{trim} in Figure 30) between the Trim and GND pins of the module. Without an external resistor between the Trim and GND pins, the output of the module will be at the low-end of the specified range. To calculate the value of the trim resistor, R_{trim} for a desired output voltage, use the following equations:

24V Austin Lynx™: Non-Isolated DC-DC Power Modules

20Vdc –30Vdc input; 5Vdc to 15Vdc output; 70W Output Power

Feature Descriptions (continued)

Output Voltage Programming

$$R_{trim} = \left[\frac{10500}{V_o - 5.021} - 1000 \right] \Omega$$

where, R_{trim} is the external resistor in Ω and V_o is the desired output voltage

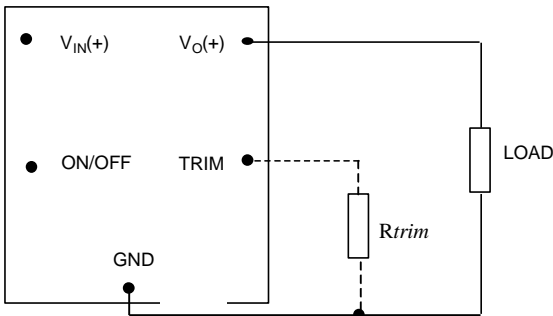

Figure 30. Circuit configuration to program output voltage using an external resistor.

By using a $\pm 0.5\%$ tolerance trim resistor with a TC of ± 100 ppm, a set point tolerance of $\pm 2\%$ can be achieved as specified in the electrical specifications. The POL Programming Tool, available at www.gecriticalpower.com under the Design Tools section, helps determine the required external trim resistor needed for a specific output voltage.

Voltage Margining

Output voltage margining can be implemented in the Austin Lynx 24V modules by connecting a resistor, $R_{margin-up}$, from the Trim pin to the ground pin for margining-up the output voltage and by connecting a resistor, $R_{margin-down}$, from the Trim pin to output pin for margining-down. Figure 31 shows the circuit configuration for output voltage margining. The POL Programming Tool, available at www.GEcriticalpower.com under the Design Tools section, also calculates the values of $R_{margin-up}$ and $R_{margin-down}$ for a specific output voltage and % margin. Please consult your local GE technical representative for additional details.

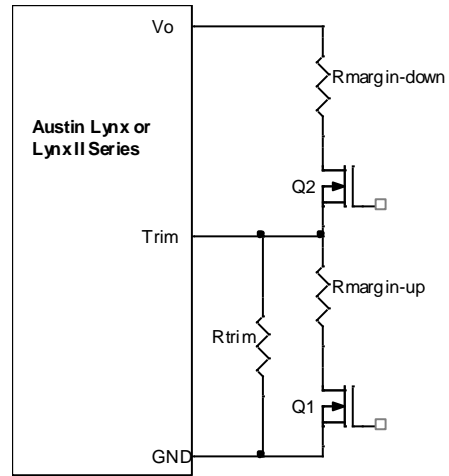

Figure 31. Circuit Configuration for margining the output voltage.

24V Austin Lynx™: Non-Isolated DC-DC Power Modules

20Vdc –30Vdc input; 5Vdc to 15Vdc output; 70W Output Power

Thermal Considerations

Power modules operate in a variety of thermal environments; however, sufficient cooling should always be provided to help ensure reliable operation.

Considerations include ambient temperature, airflow, module power dissipation, and the need for increased reliability. A reduction in the operating temperature of the module will result in an increase in reliability. The thermal data presented here is based on physical measurements taken in a wind tunnel. The test set-up is shown in Figure 32. Note that the airflow is parallel to the long axis of the module as shown in figure 32. The derating data applies to airflow in either direction of the module’s long axis.

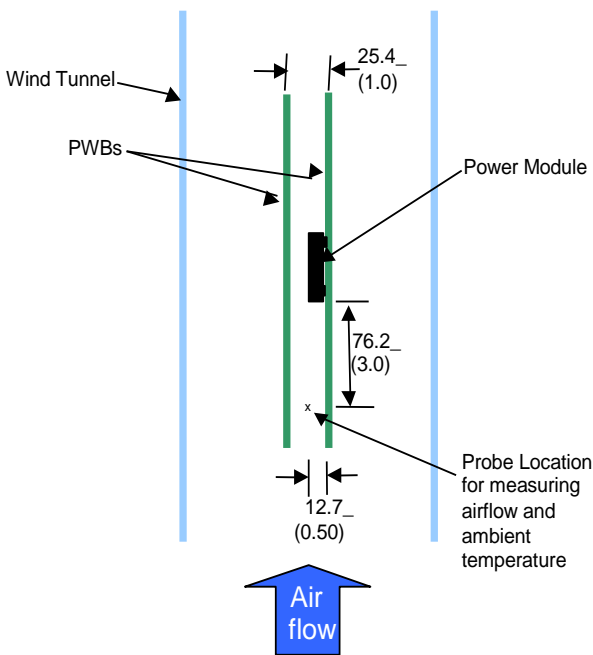
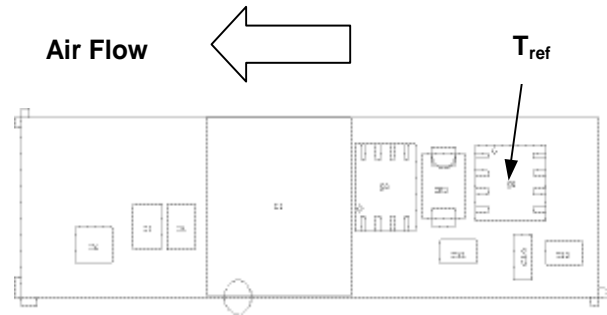

Figure 32. Thermal Test Set-up.

The thermal reference point, T_{ref} used in the specifications is



Top View

Figure 33. T_{ref} Temperature measurement location.

shown in Figure 33. For reliable operation this temperature should not exceed 125°C.

The output power of the module should not exceed the rated power of the module ($V_{o,set} \times I_{o,max}$).

Please refer to the Application Note “Thermal Characterization Process For Open-Frame Board-Mounted Power Modules” for a detailed discussion of thermal aspects including maximum device temperatures.

24V Austin Lynx™: Non-Isolated DC-DC Power Modules

20Vdc –30Vdc input; 5Vdc to 15Vdc output; 70W Output Power

Mechanical Outline

Dimensions are in millimeters and (inches).

Tolerances: x.x mm ± 0.5 mm (x.xx in. ± 0.02 in.) [unless otherwise indicated]

x.xx mm ± 0.25 mm (x.xxx in ± 0.010 in.)

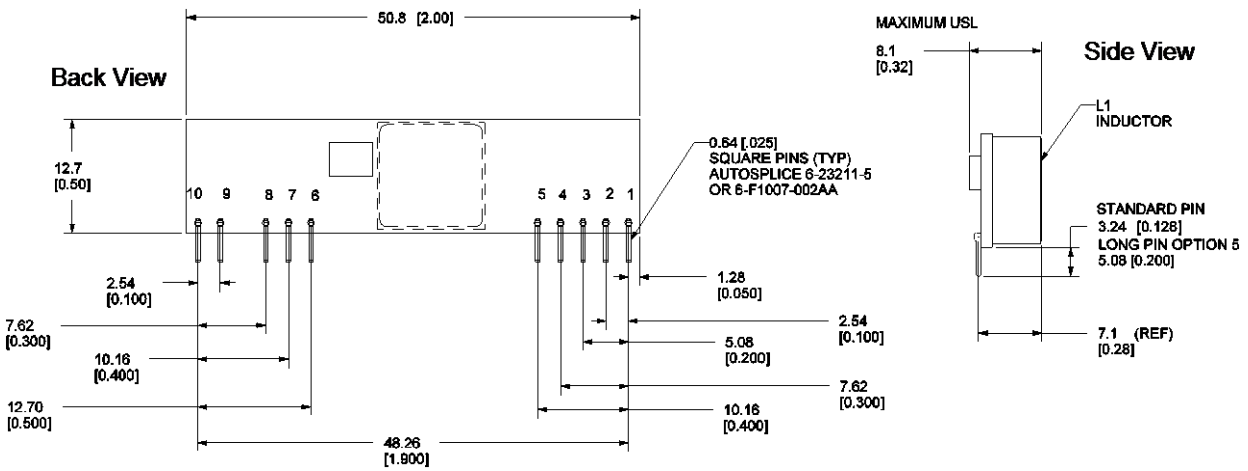

Pin	Function
1	V _o
2	V _o
3	V _{o,sense}
4	V _o
5	GND
6	GND
7	V _{IN}
8	V _{IN}
9	TRIM
10	ON/OFF

24V Austin Lynx™: Non-Isolated DC-DC Power Modules
 20Vdc –30Vdc input; 5Vdc to 15Vdc output; 70W Output Power

Recommended Pad Layout

Dimensions are in millimeters and (inches).

Tolerances: x.x mm ± 0.5 mm (x.xx in. ± 0.02 in.) [unless otherwise indicated]

x.xx mm ± 0.25 mm (x.xxx in ± 0.010 in.)

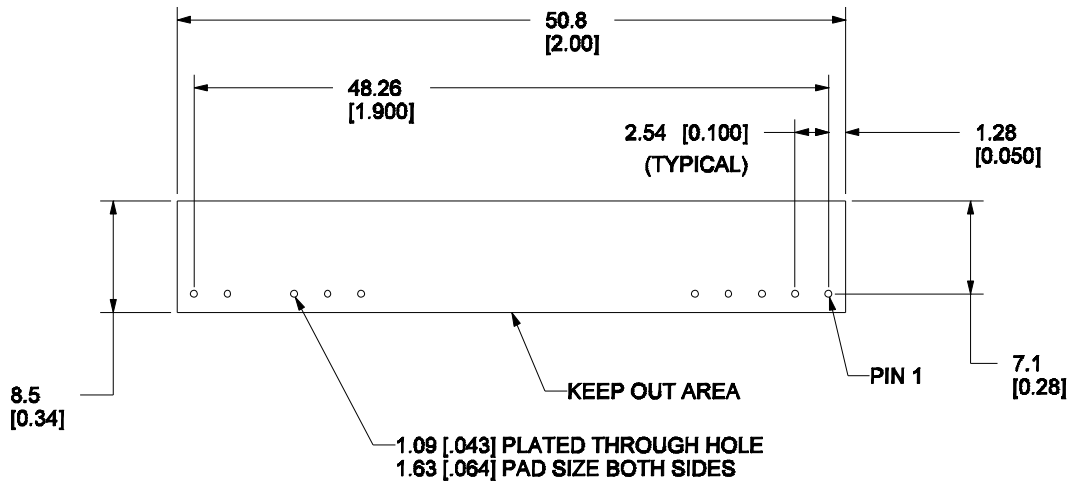

RECOMMENDED HOLE PATTERN
 COMPONENT-SIDE FOOTPRINT

Pin	Function
1	V _o
2	V _o
3	V _{o,sense}
4	V _o
5	GND
6	GND
7	V _{IN}
8	V _{IN}
9	TRIM
10	ON/OFF

24V Austin Lynx™: Non-Isolated DC-DC Power Modules

20Vdc – 30Vdc input; 5Vdc to 15Vdc output; 70W Output Power

Ordering Information

Please contact your GE Sales Representative for pricing, availability and optional features.

Table 3. Device Code

Device Code	Input Voltage Range	Output Voltage	Output Power	On/Off Logic	Connector Type	Comcodes
AXB070X43	20 – 30Vdc	5.0 – 15.0Vdc	70W	Positive	TH	CC109105616

-Z refers to RoHS-compliant codes



Contact Us

For more information, call us at

USA/Canada:

+1 877 546 3243, or +1 972 244 9288

Asia-Pacific:

+86.021.54279977*808

Europe, Middle-East and Africa:

+49.89.878067-280

www.gecriticalpower.com

GE Critical Power reserves the right to make changes to the product(s) or information contained herein without notice, and no liability is assumed as a result of their use or application. No rights under any patent accompany the sale of any such product(s) or information.