

Rear Shell

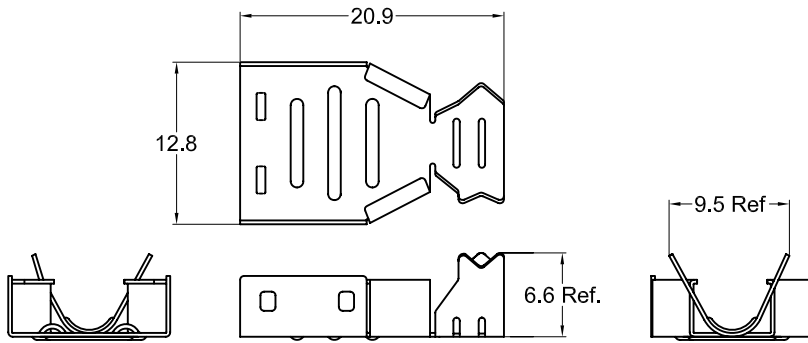

Strain Relief

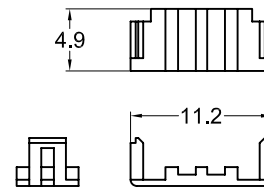

Front Shell

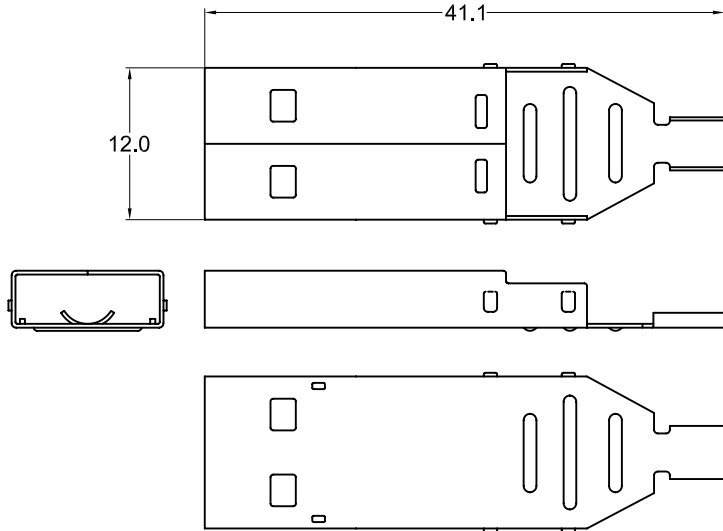

Insulator Body

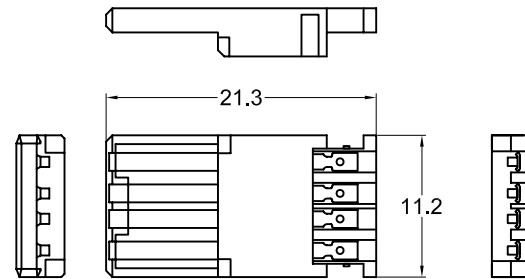

Materials and Finish

Shell:
Steel or Phosphor Bronze
0.3mm thickness

Insulator:
PBT Thermoplastic
UL 94V-0 Rated
White Color

Contact Plating-
Standard: Glod flash plated
30 option: 30u" gold plated.

Recommended Cable Size:
Ø3.4 to Ø5.3 outer diameter

Electrical Characteristics

Contact Resistance:
30 milliohm max. initial

Insulation Resistance:
1000 Megohm min.

Dielectric Withstanding Voltage:
500V AC (rms) min.

Voltage Rating: 30V AC (rms)

Current Rating: 1.5A max.
per contact at 30°C T-Rise

Operating Temperature:
-55°C to +85°C

Ordering Information

Part Number	Contact Area Plating
KUSBX-AP-KIT-SC	Gold Flash (standard)
KUSBX-AP-KIT-SC-30	30u" Gold (-30 option)



Tolerances
X.X ± 0.25
X.XX ± 0.15
Unless Stated
Otherwise

REV.	DATE	DESCRIPTION	REV. BY	CHK. BY	DRAWN BY	DATE
A1	6/27/05	New Drawing	N.Chang	C. Furumasu	N.Chang	6/27/05
A2	6/14/06	Add 30 option	H. MA	C. Furumasu		
A3	10/07/10	ECO #10-070	S. Vien	H. MA		

KUSBX-AP-KIT-SC

USB A-type Plug Assembly, RoHS Compliant

With Solder Cup ends, page 1 of 2



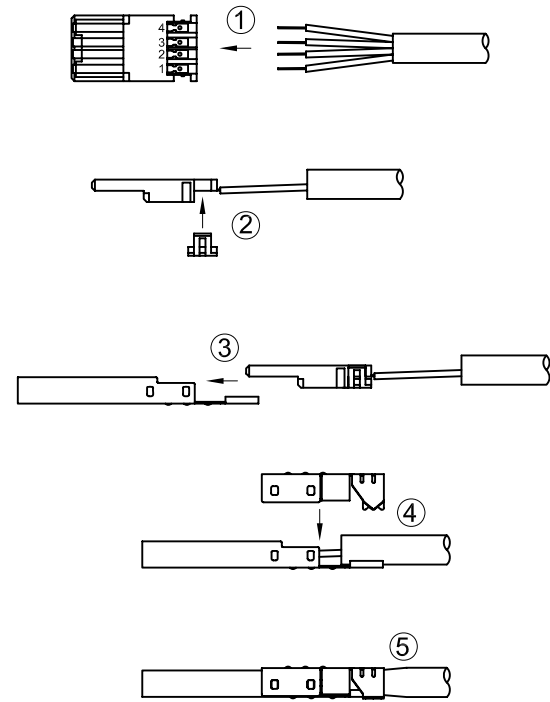
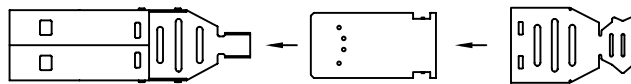
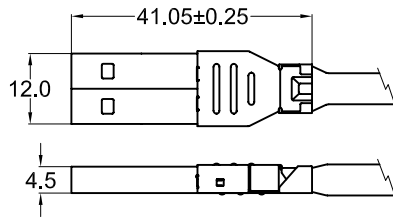
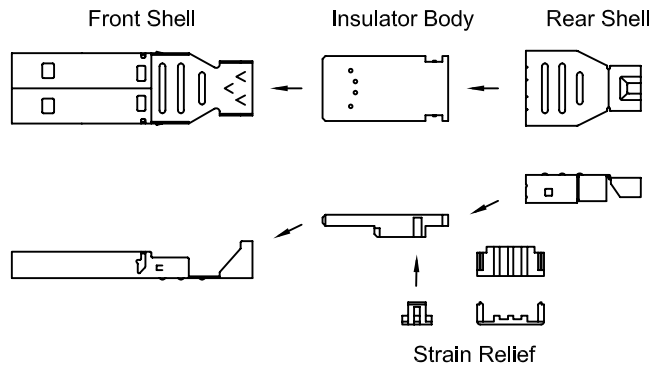
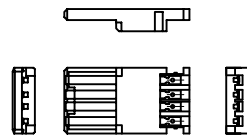
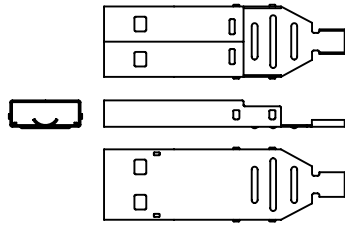
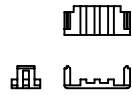
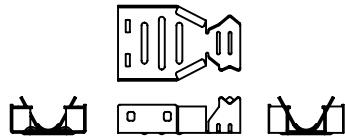

Assembly Instructions

- 1) Solder cable wires to Insulator Body.
- 2) Snap Strain Relief onto Insulator Body.
- 3) Place Strain Relief/Insulator Body assembly into Front Shell and push forward until firmly seated in place.
- 4) Snap Rear Shield onto Front Shield.
- 5) Crimp Rear Shield tail over Front Shield.

RoHS COMPLIANT
EU Directive 2002/95/EC

Tolerances
X.X ± 0.25
X.XX ± 0.15
Unless Stated
Otherwise

REV.	DATE	DESCRIPTION	REV. BY	CHK. BY	DRAWN BY	DATE
A1	6/27/05	New Drawing	N.Chang	C. Furumasu	N.Chang	6/27/05
A2	6/14/06	Add 30 option	H. MA	C. Furumasu		
A3	10/07/10	ECO #10-070	S. Vien	H. MA		

KUSBX-AP-KIT-SC

USB A-type Plug Assembly, RoHS Compliant

With Solder Cup ends, page 2 of 2

