

SPECIFICATION FOR APPROVAL

承 認 書

Description : Electret Condenser Microphone

Kingstate Part No. : KEBG6544PF

Customer's Model No. : _____

Specification No. : MKS-7125

Number Of The Edition : 1.1

CUSTOMER'S APPROVED SIGNATURE		

志豐電子股份有限公司 **KINGSTATE ELECTRONICS CORP.**





Address: 10F, No. 69-11, Sec. 2, Chung Cheng E. Rd., Tamshui County, Taipei Hsien, Taiwan, R.O.C.

International sales dept.: TEL:886-2-2809-5651 FAX:886-2-2809-7151

Domestic sales dept.: TEL:886-2-2809-0668 FAX:886-2-28096748

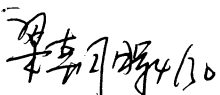
<http://www.kingstate.com.tw>

Approved by	Checked by	Issued by
	 04.30	Qin 04/30/09'

A. SCOPE 範疇

This specification applies electret condenser microphone, **KEBG6544PF**

此規格書適用於電容式麥克風 **KEBG6544PF**

B. SPECIFICATION 規格

No.	Item	Symbol	Unit	Specification	Condition
1	Directivity 方向性			Omnidirectional 全指向	
2	Sensitivity 靈敏度	S	dB	-44 ± 3	f=1KHz, 1Pa 0dB=1V/Pa
3	Standard operating voltage 標準操作電壓	Vs	V D.C.	4.5	
4	Output impedance 輸出阻抗	Zout	KΩ	1.0	f=1KHZ, 1Pa
5	Max operating voltage 最大操作電壓		V D.C.	10	
6	Sensitivity reduction 減電壓靈敏度	S-Vs	dB	-3	f=1KHz, 1Pa Vs=4.5V D.C. to 1.5V D.C.
7	Frequency 頻率	f	Hz	20 ~ 20,000	
8	Max. current consumption 最大耗電流	IDSS	mA	0.5	Vs=4.5V D.C.RL=1.0 KΩ
9	Signal to noise ration 訊號對雜音比	S/N	dBA	60	f=1KHz, 1Pa A weighted
10	Operation temp. 操作溫度			-20 ~ +70	
11	Storage temp. 儲存溫度			-20 ~ +70	
12	Dimension 尺寸		mm	φ9.4 x 6.5	See appearance drawing 請參照外觀尺寸圖
13	Weight (MAX) 重量		gram	0.7	
14	Material 材質			AL 鋁	
15	Terminal 端子			Pin type (鍍錫/Plating Sn)	See appearance drawing 請參照外觀尺寸圖 (Hand Soldering Only)
16	Environmental Protection Regulation 環保法規			RoHS	

We use "Pascal (Pa)" indication of sensitivity as per the recommendation of I.E.C.(International Electro technical Commission).The Sensitivity of "Pa" will increase 20dB comparing with "ubar" indication.

Example: -60dB (0dB=1V/ubar) =-40dB (1V/Pa)

依I.E.C.(國際電子協會)建議,以"Pa"為靈敏度標示單位比"ubar" 靈敏度標示單位增加20dB

例如: -60dB (0dB=1V/ubar) = -40dB (1V/Pa)

C. TYPICAL FREQUENCY RESPONSE CURVE 頻率響應曲線

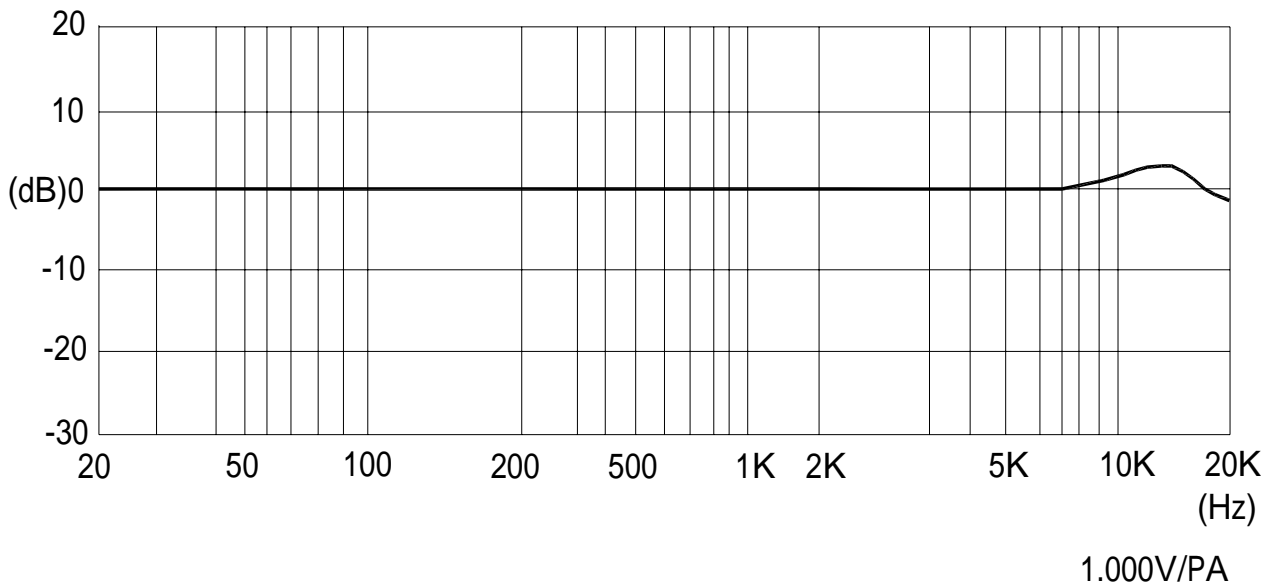

D. APPEARANCE DRAWING 外觀尺寸圖

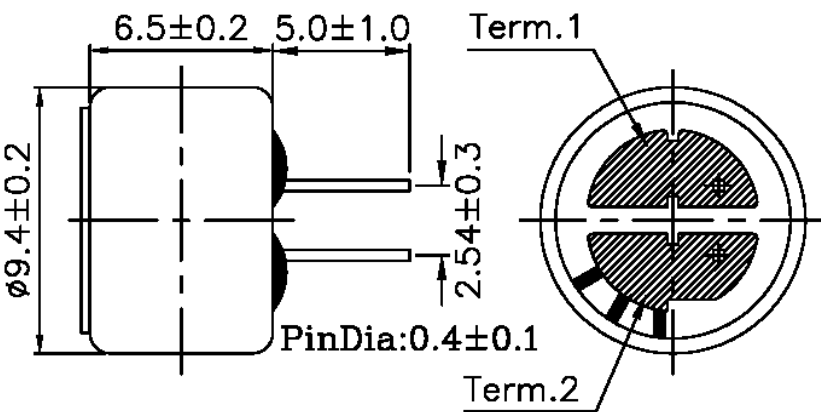

Unit: mm

E. MEASUREMENT CIRCUIT 測量線路

測量線路

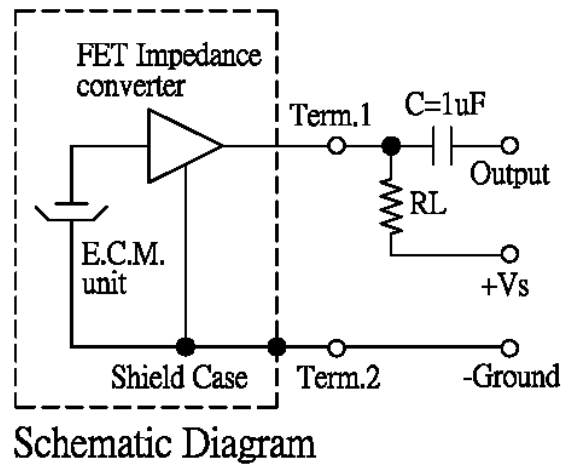

RL=1.0K

F. MECHANICAL CHARACTERISTICS 機械特性

No.	Item	Test condition	Evaluation standard
1	Soldering Heat Resistance 焊錫耐熱性	Lead terminal are immersed in soldering bath of $+270\pm 5$ for 2 ± 0.5 second. 端子部份浸入以 $+270\pm 5$ 焊錫槽中 2 ± 0.5 秒.	No interference in operation 操作無任何不良
2	Terminal Mechanical Strength 端子強度	Apply the terminal with 4.9N(0.5kg) strength for 30 second. 對端子施以 4.9N(0.5kg)力量 30 秒.	No damage and cutting off 端子不鬆動,不脫落
3	Vibration Test 振動測試	The part shall be measured after being applied vibration of amplitude of 1.5mm with 10 to 55hz band of vibration frequency to each of 3 per-pendicular directions for 2 hours. 振動週波數 10 55HZ、全振幅 1.5mm 於 X.Y.Z 3 個方向, 各 2 小時.	After any tests, the sensitivity to be within $\pm 3\text{dB}$ 測試其靈敏度須與原測試值的差異不超過 ± 3 dB.
4	Drop Test 落下測試	The part unit without packaged must be subjected to each 3 drops at three axes from the height of 1 meter to 20 mm thick wooden board. 未包裝麥克風單體從 1 公尺高處, X.Y.Z.3 個方向, 各 3 回, 落於 20mm 厚木板上.	

G. ENVIRONMENTAL TEST 環境試驗

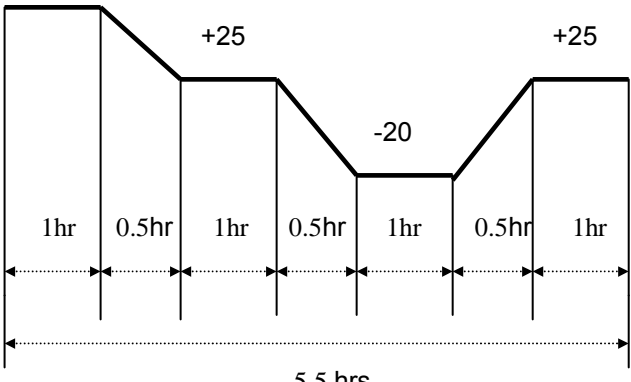
No.	Item	Test conditions	Evaluation standard
1	High temp. test 高溫測試	After being placed in a chamber at $+70$ for 72 hours. 置於 $+70$ 環境中 72 小時	After any tests, the sensitivity to be within $\pm 3\text{dB}$ of initial sensitivity after 6 hours of conditioning at $+25$ 經測試後麥克風, 須靜置於 $+25$ (室溫) 環境中 6 小時後. 測試其靈敏度須與原測試值的差異不超過 ± 3 dB
2	Low temp. test 低溫測試	After being placed in a chamber at -20 for 72 hours. 置於 -20 環境中 72 小時	
3	Humidity test 相對濕度測試	After being placed in a chamber at $+40$ and $90\pm 5\%$ relative humidity for 240 hours. 置於 $+40$, 相對濕度 $90\pm 5\%$ 環境中 240 小時	
4	Temp. cycle test 溫度循環測試	The part shall be subjected to 10 cycles. One cycle shall be consist of: 單體承受溫度循環測試 10 次, 其循環內容如圖示: 	

TEST CONDITION.

Standard Test Condition	: a) Temperature : $+5 \sim +35$	b) Humidity : 45-85%	c) Pressure : 860-1060mbar
一般測試條件	: a) 溫度 : $+5 \sim +35$	b) 濕度 : 45-85%	c) 氣壓 : 860-1060mbar
Judgement Test Condition	: a) Temperature : $+25 \pm 2$	b) Humidity : 60-70%	c) Pressure : 860-1060mbar
爭議時測試條件	: a) 溫度 : $+25 \pm 2$	b) 濕度 : 60-70%	c) 氣壓 : 860-1060mbar

H. PACKING STANDARD 包裝規格

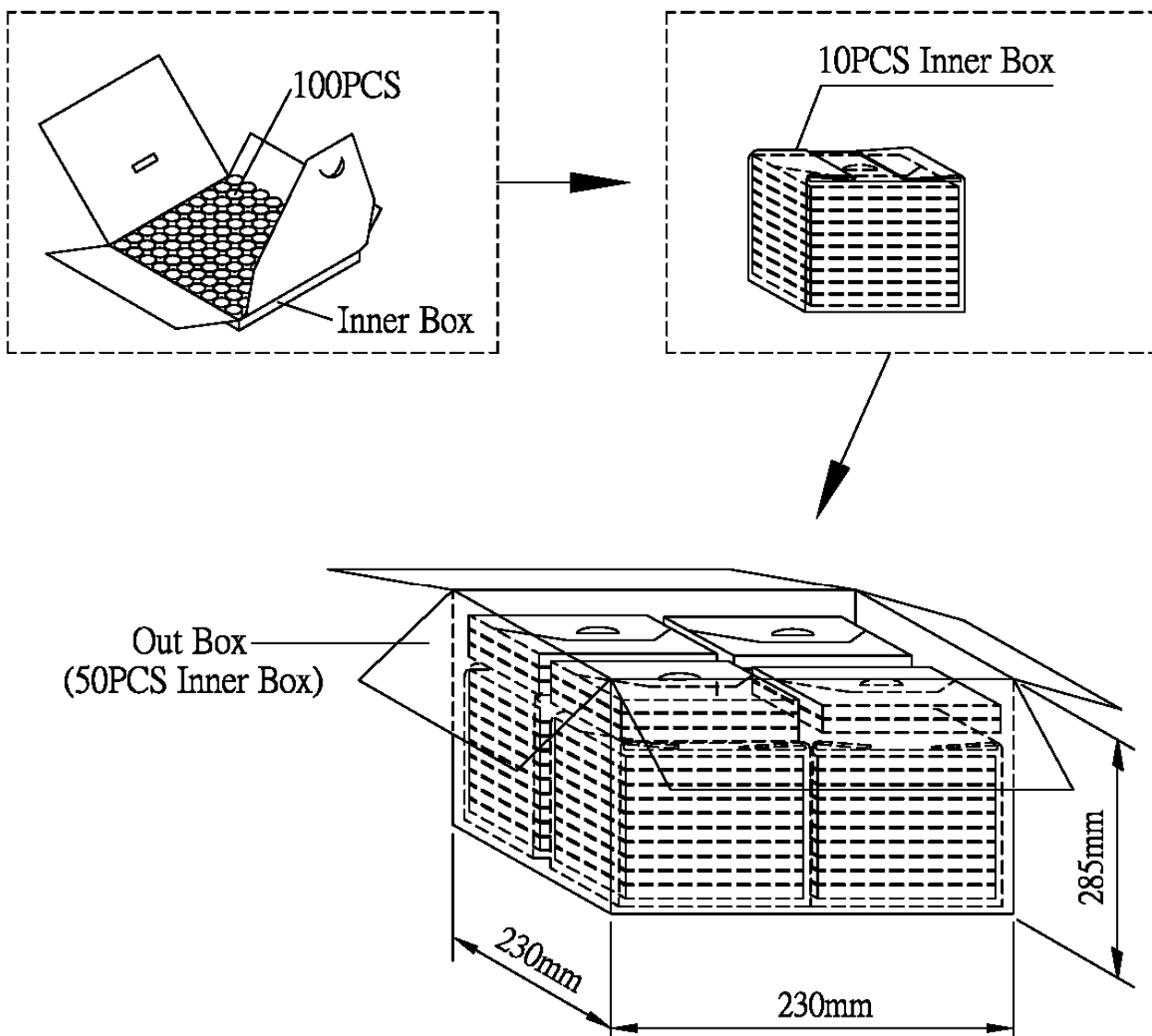

Inner Box	100mmx100mmx8mm	1x100PCS=100PCS
Out Box	230mmx230mmx285mm	100PCSx50=5,000PCS